

タダノ オールテレークレーン

ATF-400G6(J) 型

仕様書

型式呼称	ATF-400G6(J)
キャリヤ	FAUN ATF400G-6
スペック番号	ATF-400G-1-90101, 90102

株式会社 タダノ

構成図

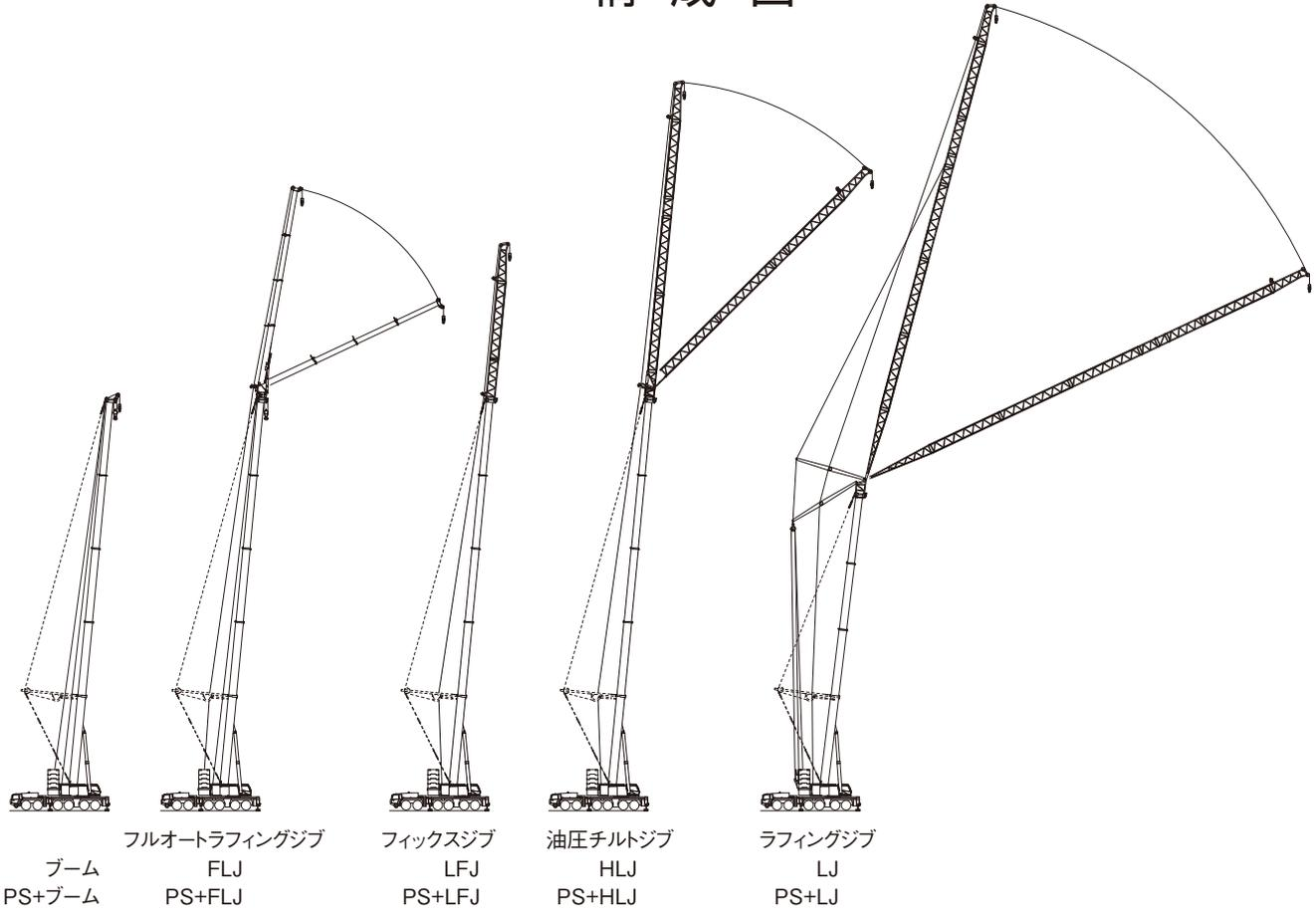

・ATF-400G-1 (90101、90102 スペック) のジブは、フルオートラフィングジブ(FLJ)、フィックスジブ(LFJ)、油圧チルトジブ(HLJ)、ラフィングジブ(LJ)の4種類があります。

・アタッチメントのPSは、ブームのたわみを抑えて定格総荷重を大きくする装置です。ブーム、およびそれぞれのジブ付き状態に取り付けることができます。

・重荷重装置 は90101スペックに付き、90102スペックには付きません。それにもない、最大定格総荷重は次のようになります。

スペック	最大定格総荷重
90101	400 t
90102	200 t

カウンタウイトとアウトリガ張出幅の組合せによって次のように定格総荷重表を選定し該当ページを読み取ってください。

ブーム		カウンタウイト										
ブーム	アウトリガ張出幅	138 t	118 t	98 t	78 t	58 t	47 t	25 t	16.5 t	7.5 t	0 t	
		8.5 m	○	○	○	○	○	○	○	○	○	○
	8.0 m	—	○	○	○	○	○	○	○	○	○	
	6.8 m	—	—	—	○	○	○	○	○	○	○	
	5.5 m	—	—	—	—	—	○	○	○	○	○	
	2.7 m	—	—	—	—	—	—	—	—	—	○	

ブーム

PS+ブーム		カウンタウイト										
PS+ブーム	アウトリガ張出幅	138 t	118 t	98 t	78 t	58 t	47 t	25 t	16.5 t	7.5 t	0 t	
		8.5 m	○	○	○	○	○	○	○	—	—	○
	8.0 m	—	○	○	○	○	○	○	—	—	○	
	6.8 m	—	—	—	○	○	○	○	—	—	○	

PS+ブーム

ブーム+フルオートラフingジブ(FLJ)		カウンタウイト							
ブーム FLJ	アウトリガ張出幅	138 t	118 t	98 t	78 t	58 t	47 t	25 t	
		8.5 m	—	○	○	○	○	○	○
	8.0 m	—	○	○	○	○	○	○	
	6.8 m	—	—	—	○	○	○	—	

FLJ

PS+ブーム+フルオートラフingジブ(FLJ)		カウンタウイト							
PS+ブーム FLJ	アウトリガ張出幅	138 t	118 t	98 t	78 t	58 t	47 t	25 t	
		8.5 m	○	○	○	○	○	○	○
	8.0 m	—	○	○	○	○	○	—	
	6.8 m	—	—	—	○	○	○	—	

PS+FLJ

ブーム+フィックスジブ(LFJ)		カウンタウイト							
ブーム LFJ	アウトリガ張出幅	138 t	118 t	98 t	78 t	58 t	47 t	25 t	
		8.5 m	—	—	○	○	○	○	○
	8.0 m	—	—	○	○	○	○	○	
	6.8 m	—	—	—	○	○	○	○	

LFJ

PS+ブーム+フィックスジブ(LFJ)		カウンタウイト							
PS+ブーム LFJ	アウトリガ張出幅	138 t	118 t	98 t	78 t	58 t	47 t	25 t	
		8.5 m	○	○	○	○	○	○	○
	8.0 m	—	○	○	○	○	○	○	
	6.8 m	—	—	—	○	○	○	○	

PS+LFJ

ブーム+油圧チルトジブ(HLJ)		カウンタウイト							
ブーム HLJ	アウトリガ張出幅	138 t	118 t	98 t	78 t	58 t	47 t	25 t	
		8.5 m	—	○	○	○	○	○	○
	8.0 m	—	○	○	○	○	○	○	
	6.8 m	—	—	—	○	○	○	○	

HLJ

PS+ブーム+油圧チルトジブ(HLJ)		カウンタウイト							
PS+ブーム HLJ	アウトリガ張出幅	138 t	118 t	98 t	78 t	58 t	47 t	25 t	
		8.5 m	○	○	○	○	○	○	○
	8.0 m	—	○	○	○	○	○	○	
	6.8 m	—	—	—	○	○	○	○	

PS+HLJ

ブーム+ラフingジブ(LJ)		カウンタウイト					
ブーム LJ	アウトリガ張出幅	138 t	118 t	98 t	78 t	58 t	47 t
		8.5 m	○	○	○	○	○
	8.0 m	—	○	○	○	○	○
	6.8 m	—	—	○	○	—	—

LJ

PS+ブーム+ラフingジブ(LJ)		カウンタウイト					
PS+ブーム LJ	アウトリガ張出幅	138 t	118 t	98 t	78 t	58 t	47 t
		8.5 m	○	○	○	○	○
	8.0 m	—	○	○	○	○	○
	6.8 m	—	—	○	○	—	—

PS+LJ

注) —印の組合せでは、クレーン作業を行わないでください。

諸元

■クレーン

ブーム	15.0m	400.0t × 2.7m (46本掛)※ 200.0t × 4.0m (20本掛)	※重荷重装置付きスベック
	20.1m	170.0t × 5.0m (17本掛)	
	25.1m	162.0t × 5.0m (16本掛)	
	30.2m	139.0t × 6.0m (13本掛)	
	35.3m	123.4t × 5.0m (12本掛)	PS付き
	40.4m	84.2t × 8.0m (8本掛)	84.2t × 9.0m (8本掛)
	45.4m	71.6t × 8.0m (7本掛)	68.0t × 12.0m (6本掛)
	50.5m	54.3t × 10.0m (5本掛)	58.0t × 14.0m (5本掛)
	55.6m	45.0t × 11.0m (4本掛)	45.0t × 11.0m (4本掛)
60.0m	34.5t × 14.0m (3本掛)	34.9t × 10.0m (3本掛)	
シングルトップ	12.2t (1本掛)		
フルオート ラフィングジブ (FLJ)	2.3m+10.3m FLJ	38.4t × 9.0m (4本掛)	37.6t × 14.0m (4本掛)
	2.3m+17.2m FLJ	16.7t × 24.0m (2本掛)	16.7t × 26.0m (2本掛)
	2.3m+24.1m FLJ	16.0t × 14.0m (2本掛)	16.4t × 14.0m (2本掛)
	2.3m+31.0m FLJ	10.9t × 16.0m (1本掛)	10.9t × 18.0m (1本掛)
フィックスジブ (LFJ)	6.0m LFJ	50.2t × 8.0m (5本掛)	58.6t × 12.0m (5本掛)
	12.0m LFJ	43.1t × 9.0m (4本掛)	47.4t × 11.0m (4本掛)
	18.0m LFJ	32.8t × 11.0m (3本掛)	33.3t × 11.0m (3本掛)
	24.0m LFJ	23.8t × 12.0m (2本掛)	23.7t × 12.0m (2本掛)
油圧チルトジブ (HLJ)	2.0m+3.5m HLJ	47.7t × 8.0m (5本掛)	58.6t × 12.0m (5本掛)
	2.0m+11.5m HLJ	38.8t × 10.0m (4本掛)	45.4t × 11.0m (4本掛)
	2.0m+17.5m HLJ	31.5t × 11.0m (3本掛)	32.6t × 14.0m (3本掛)
	2.0m+23.5m HLJ	25.7t × 12.0m (3本掛)	24.7t × 16.0m (3本掛)
	2.0m+29.5m HLJ	20.4t × 14.0m (2本掛)	18.7t × 20.0m (2本掛)
	2.0m+35.5m HLJ	17.2t × 14.0m (2本掛)	14.1t × 22.0m (2本掛)
	2.0m+41.5m HLJ	13.4t × 16.0m (2本掛)	10.1t × 28.0m (1本掛)
	2.0m+47.5m HLJ	10.7t × 16.0m (1本掛)	6.7t × 32.0m (1本掛)
ラフィングジブ (LJ)	2.5m+20.3m LJ	69.7t × 14.0m (6本掛)	39.8t × 16.0m (4本掛)
	2.5m+32.3m LJ	58.6t × 14.0m (5本掛)	30.8t × 18.0m (3本掛)
	2.5m+34.0m LJ	40.8t × 18.0m (4本掛)	27.8t × 18.0m (3本掛)
	2.5m+40.0m LJ	36.7t × 14.0m (4本掛)	20.8t × 20.0m (2本掛)
	2.5m+46.0m(ヘビー)LJ	36.7t × 16.0m (4本掛)	17.1t × 22.0m (2本掛)
	2.5m+52.0m(ヘビー)LJ	29.8t × 18.0m (3本掛)	15.5t × 24.0m (2本掛)
	2.5m+58.0m(ヘビー)LJ	21.8t × 20.0m (2本掛)	14.1t × 26.0m (2本掛)
	2.5m+64.0m(ヘビー)LJ	18.6t × 24.0m (2本掛)	12.3t × 28.0m (2本掛)
	2.5m+70.0m LJ	15.9t × 26.0m (2本掛)	10.3t × 32.0m (1本掛)
	2.5m+76.0m LJ	12.8t × 28.0m (2本掛)	8.6t × 36.0m (1本掛)
	2.5m+46.0m(ライト)LJ	25.8t × 16.0m (3本掛)	17.7t × 22.0m (2本掛)
	2.5m+52.0m(ライト)LJ	18.8t × 18.0m (2本掛)	14.0t × 26.0m (2本掛)
	2.5m+58.0m(ライト)LJ	20.9t × 22.0m (2本掛)	14.1t × 26.0m (2本掛)
	2.5m+64.0m(ライト)LJ	16.5t × 24.0m (2本掛)	12.2t × 28.0m (1本掛)
最大地上揚程	ブーム	60m (34.5t)	60m (34.9t)
	FLJ	93m (5.7t)	93m (5.3t)
	LFJ	85m (13.3t)	85m (11.2t)
	HLJ	110m (5.6t)	99m (3.3t)
	LJ	122m (5.1t)	122m (4.8t)
最大作業半径	ブーム	58m (5.8t)	58m (3.7t)
	FLJ	66m (1.9t)	66m (2.2t)
	LFJ	78m (2.5t)	78m (2.5t)
	HLJ	82m (1.8t)	86m (1.6t)
	LJ	86m (2.0t)	82m (3.2t)

諸 元

ブーム・ジブ長	ブーム	15.0m ~ 60.0m
	FLJ	2.3m + 10.3m ~ 31.0m
	LFJ	6.0m, 12.0m, 18.0m, 24.0m
	HLJ	2.0m + 3.5m, 11.5m, 17.5m, 23.5m, 29.5m, 35.5m, 41.5m, 47.5m
	LJ	2.5m + 20.3m, 32.3m, 34.0m, 40.0m, 46.0m(ヘビー、ライト), 52.0m(ヘビー、ライト), 58.0m(ヘビー、ライト), 64.0m(ヘビー、ライト), 70m, 76m
ブーム・ジブ形	ブーム	箱型5段油圧伸縮式、各段ピンロック方式
	FLJ	箱型4段同時伸縮式、オフセット 5° ~ 60° 油圧無段階傾斜式
	LFJ	ラチス型、オフセット0° 固定式
	HLJ	ラチス型、オフセット0° ~ 40° 油圧無段階傾斜式
	LJ	ラチス型、オフセット油圧無段階傾斜式
シングルトップ	先端ブーム取付横折曲格納式	
ブーム・ジブ伸縮装置	ブーム	複動油圧シリンダ直押し1本、圧力補償付流量調整弁付
	FLJ	複動油圧シリンダ直押し1本、ワイヤロープ式伸縮装置2基
ブーム伸長速度		45m / 500s
フック		200tフック(10枚シープ)、80tフック(3枚シープ)、35tフック(1枚シープ)、12.2tフック
巻上装置		油圧モータ駆動遊星歯車減速式、自動ブレーキ、高低圧切換装置付、シングルウインチ2基、圧力補償付流量調節弁付
ワイヤロープ	主巻	径23mm × 長さ350m、非自転性ワイヤロープ、スーパーストップ付
	補巻	径23mm × 長さ580m、非自転性ワイヤロープ、スーパーストップ付
巻上速度	主巻	125m/min (5層)
	補巻	135m/min (6層)
ブーム起伏装置		複動油圧シリンダ直押し1本、圧力補償付流量調整弁付
ブーム上げ速度		0° ~ 84.5° / 90s
旋回装置		油圧モータ駆動遊星歯車減速式、ローラー式スイングベアリング、手動スイッチ式ブレーキ、油圧操作式旋回ロック
旋回角度		360° 連続
旋回速度		1.0min ⁻¹
カウンタウエイト		138t, 118t, 98t, 78t, 58t, 47t, 25t, 16.5t, 7.5t, 0t
アウトリガ		全油圧式H型、スライドロック用ピン付、スライド格納式フロート、張出幅：最大8.5m、中間8.0m、6.8m、5.5m、最小2.7m

上部エンジン	形式	ベンツ OM926LA、水冷4サイクル直列6気筒直接噴射式、インタークーラー付ターボディーゼルエンジン、尿素SCRシステム付
	総排気量	6.37L
	最高出力	195kW [265PS] / 2,200min ⁻¹
	最大トルク	1,100N・m [112kgf・m] / 1,200~1,600min ⁻¹
燃料タンク容量		230L
A d B l u e タンク容量		8L
油圧ポンプ		高圧可変ピストンポンプ2個、高圧ピストンポンプ1個、高圧ギヤポンプ1個
安全装置		過負荷防止装置(AML) 作業範囲制限機能、旋回範囲制限機能、旋回自動停止機能、ブーム起伏緩停止機能、フック移動量表示機能 カウンタウエイト組合せ検出装置、個別検出式アウトリガ張出幅自動検出装置、巻過防止装置、捨巻確保装置、水準器、玉掛けロープはずれ止め、旋回ロック装置、油圧安全弁、油圧ロック装置(伸縮・起伏・巻上・ジャッキ)、ウインチドラム回転計

付 属 装 置	カウンタウエイト着脱装置、ブーム・起伏装置着脱装置、速度調整装置 (起伏・旋回・ウインチ・FLJ、HLJチルト)、風速計 (ブーム・FLJ・LFJ・HLJ・LJ)、リフトアジャスタ・リリースアジャスタ(ブーム)、オイルクーラー、集中給脂装置、AML外部表示灯、旋回警報装置、拡声器、ドラム視認モニタ、内部チルト式クレーン運転室、ヒータ付きシート、ヒータ・エアコン、ラジオ、衛星通信装置(HELLO-NET Owner's Site)
オ プ シ ョ ン	敷鉄板

■キャリヤ

最 高 速 度	85km/h	
登 坂 能 力	tanθ = 0.46	
最 小 回 転 半 径	11.6m	
全 長	15,620mm	
全 幅	3,000mm	
全 高	3,990mm	
軸 距	1,800mm+3,150mm+1,700mm+2,440mm+1,700mm	
輪 距	2,540mm	
車 両 総 重 量	全 重 量	45,400kg
	前 軸	12,110kg (1軸 + 2軸)
	後 軸	33,290kg (3軸 + 4軸 + 5軸 + 6軸)
乗 員 定 員	2名	
エ ン ジ ン	形 式	ベンツ OM502LA、水冷4サイクルV型8気筒直接噴射式、インタークーラー付ターボディーゼルエンジン、尿素SCRシステム付
	総 排 気 量	15.928L
	最 高 出 力	480kW [653PS] / 1,800min ⁻¹
	最 大 ト ル ク	3,000N・m [306kgf・m] / 1,300min ⁻¹
燃 料 タ ン ク 容 量	450L	
A d B l u e タンク容量	40L	
変 速 機	形 式	ZF TCトロニック 自動変速式、トルクコンバータ・インターダブレーキ付
	段	前進12段、後進2段
駆 動 方 式	12×6 (8) 1軸 + 3軸 + (4軸) + 5軸、デフロック装置付	
車 軸 形 式	6軸全浮動式	
懸 架 方 式	全軸ハイドロニューマチック、レベリング調整付、サスペンションストローク：+175mm、-90mm	
ス テ ア リ ン グ	左ハンドル、非常ステアリングポンプ付2系統式、パワーステアリング、特殊ステアリングモード付	
ブ レ ー キ	主 ブ レ ー キ	空気式全輪ディスクブレーキ、2系統式
	駐 車 ブ レ ー キ	3・4・5・6軸制動スプリング式
	補 助 ブ レ ー キ	変速機内蔵インターダ、排気ブレーキ
タ イ ヤ	445/95 R 25 (12輪)	
バ ッ テ リ	12V・170Ah × 2 (24V)	
付 属 装 置	集中給脂装置、バックモニタ、ヒータ・エアコン、ラジオ、仮眠用ベッド	

走行

■ 公道走行状態

単位(mm)

● キャリヤ + 旋回体 45.4 t

(公道走行時の注意事項)

1. ブーム・起伏装置およびカウンタウエイト装置を別送し、クレーン用台車のみで走行しなければなりません。
2. 道路運送車両の保安基準による保安基準緩和の認定が必要です。
3. 道路法による特殊車両の通行許可が必要です。基本通行条件 重量: Cが記載された適合証明書を取得していますが、実際の通行経路で申請して許可された条件にしたがって走行しなければなりません。

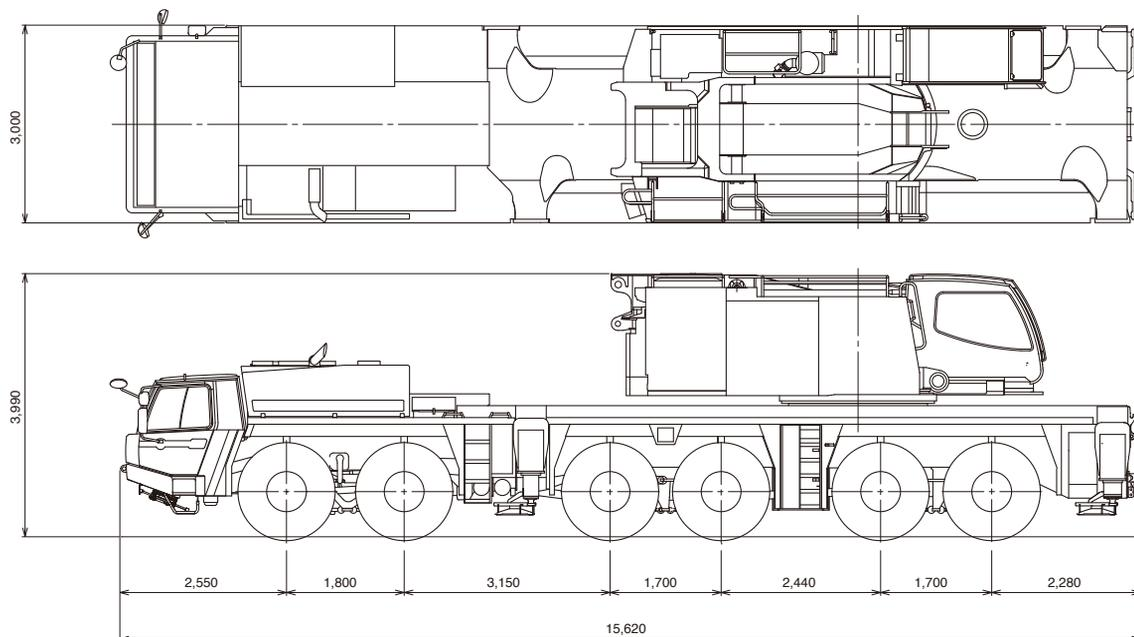

■ 構内移動姿勢

単位(mm)

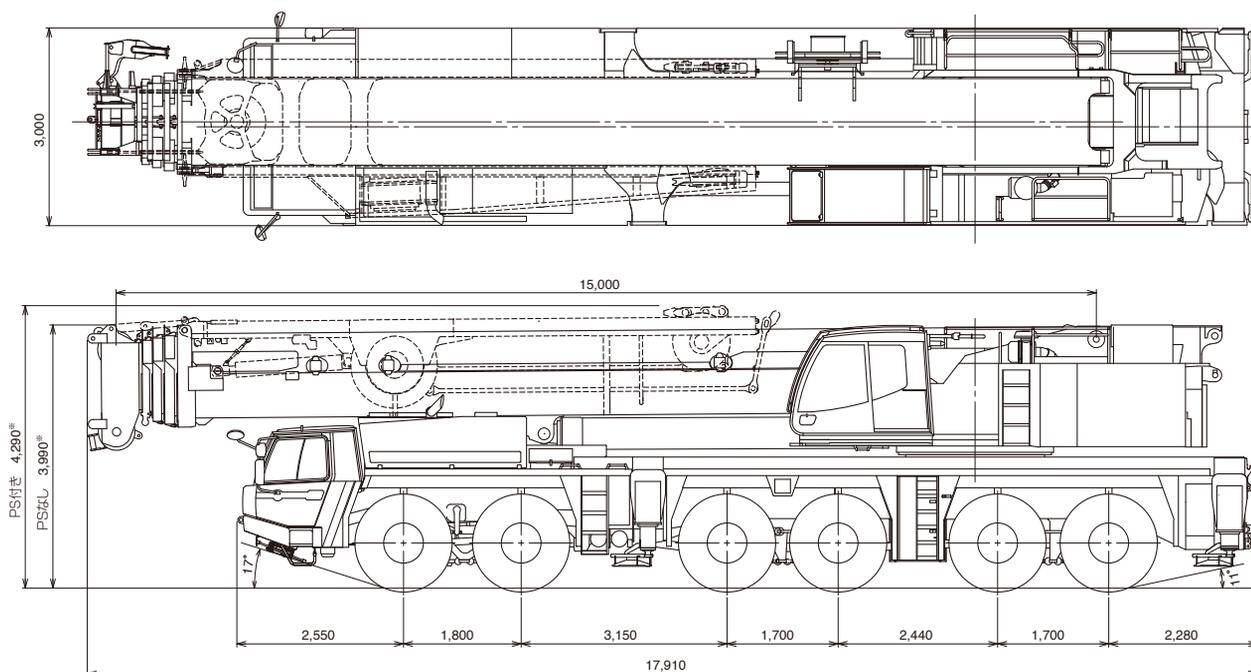

*+175mm、-90mm (サスペンション)

最低地上高: 330mm

走行

■ 最小直角通路幅

単位(mm)

● 公道走行状態

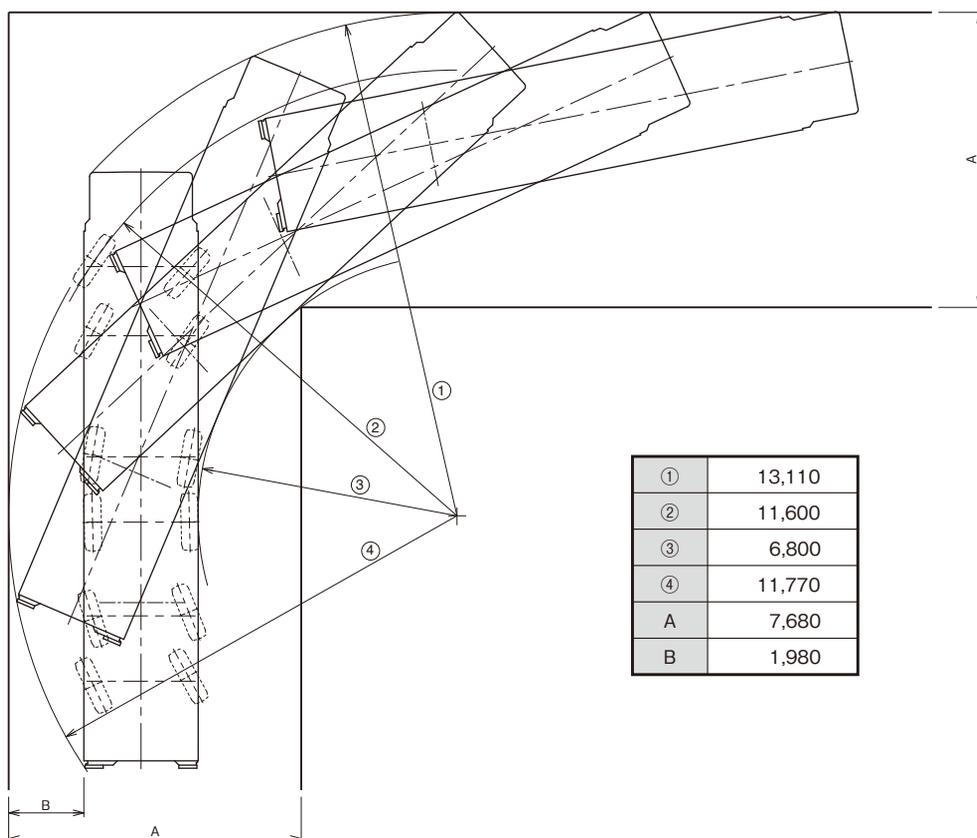

①	13,110
②	11,600
③	6,800
④	11,770
A	7,680
B	1,980

● 構内移動姿勢 (シングルトップ格納)

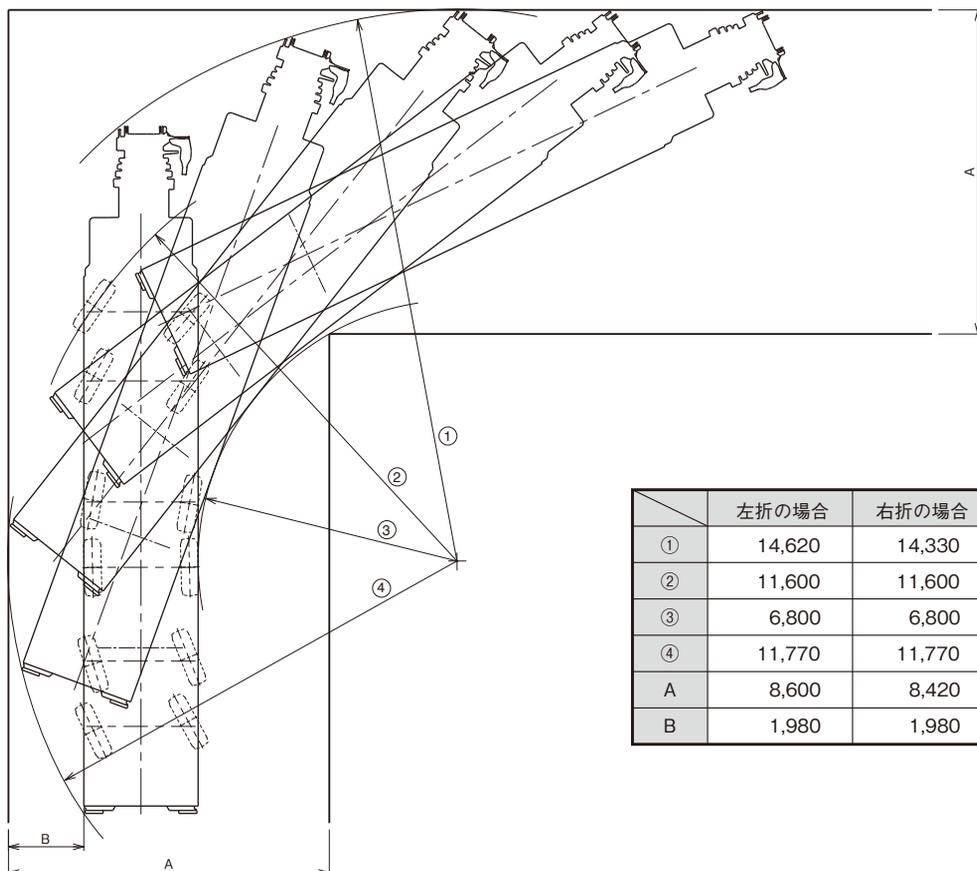

	左折の場合	右折の場合
①	14,620	14,330
②	11,600	11,600
③	6,800	6,800
④	11,770	11,770
A	8,600	8,420
B	1,980	1,980

搬 送

■ 分解搬送部品

単位(mm)

- ブーム+起伏シリンダ (ホースリール、シングルトップ付き) 28.1 t (置き台付き)
27.5 t (置き台除く)

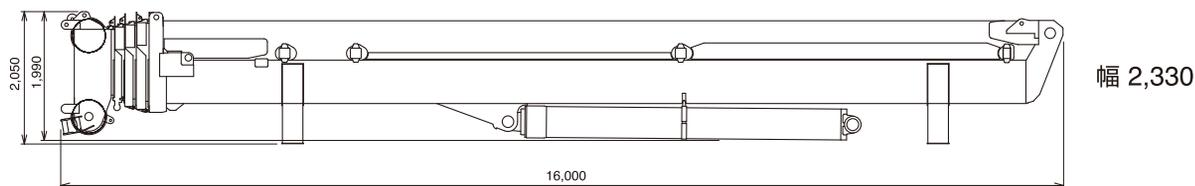

- PS 6.3 t

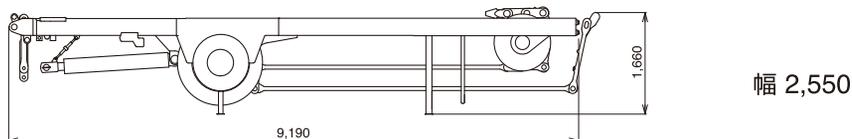

- 補巻ウインチ 4.8 t

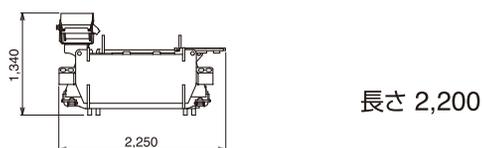

- カウンタウイト(C/W)

- ① 7.5 t

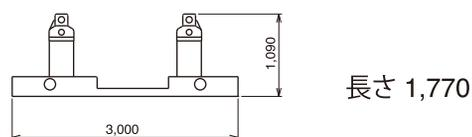

- ② 9.0 t

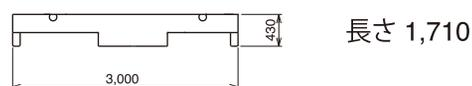

- ③ 8.5 t

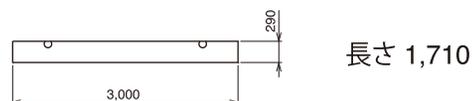

- ④ 11.0 t × 2ヶ

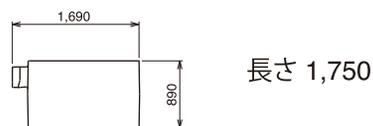

- ⑤ 11.0 t

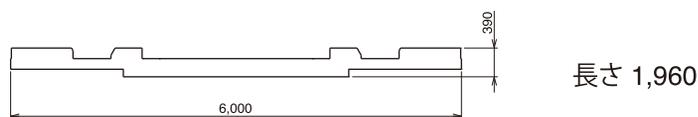

- ⑥ 10.0 t × 8ヶ

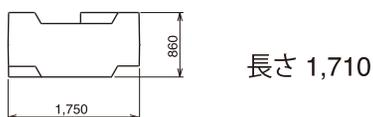

- フック

200tフック 3.2 t

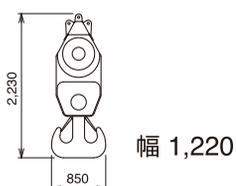

80tフック 1.55 t

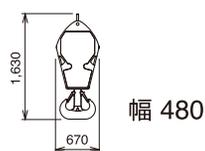

35tフック 0.95 t

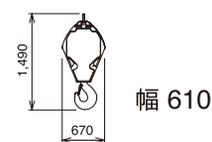

12.2tフック 0.44 t

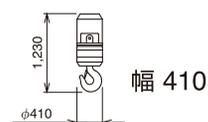

その他に付属品があります。

搬 送

■ 分解搬送部品

単位(mm)

● フルオートラフィングジブ (FLJ) 10.6 t

● アダプタ 0.8 t

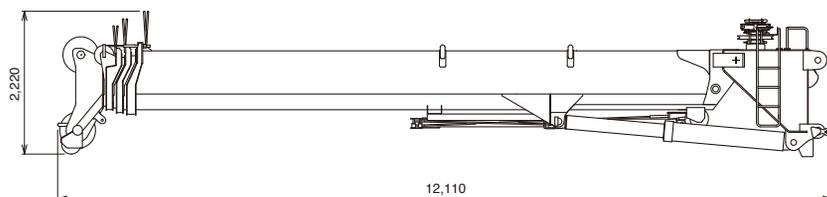

幅 1,420

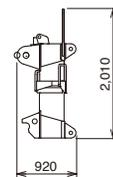

幅 2,180

● ラフィングジブ (LJ)

① ベースジブ+マスト 9.1 t

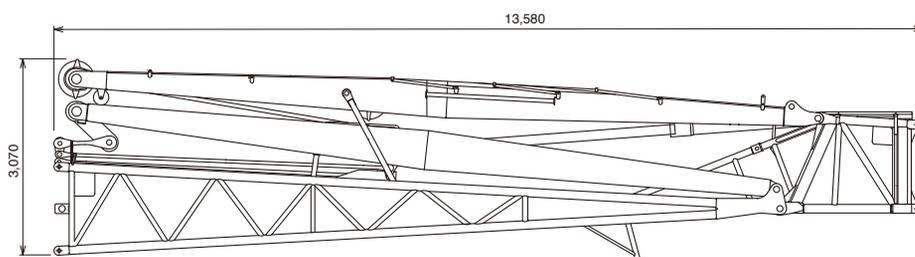

幅 2,050

② ミドルAジブ 2.8 t

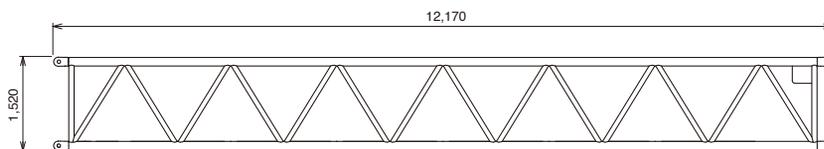

幅 1,840

③ ミドルBジブ × 2ヶ 2.1 t

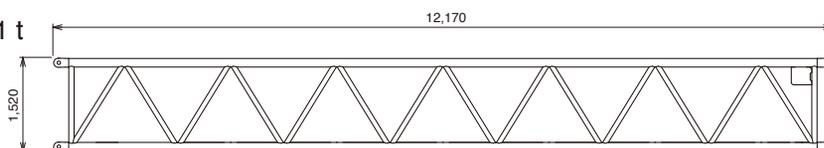

幅 1,840

④ レデューサジブ 0.75 t

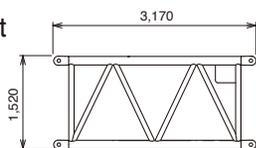

幅 1,840

⑤ ペンダントコネクタジブ 0.6 t

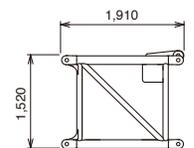

幅 1,060

⑥ ミドルCジブ 0.9 t

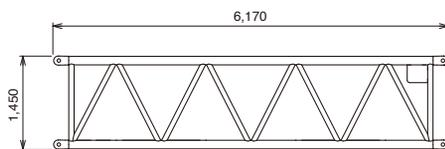

幅 1,060

⑦ ミドルDジブ 1.5 t

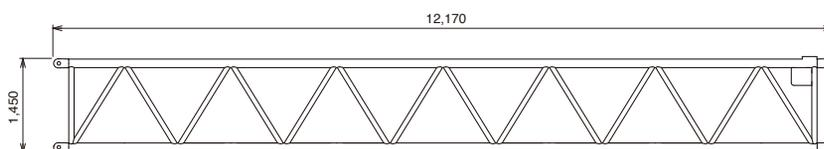

幅 1,060

⑧ トップジブ 1.45 t

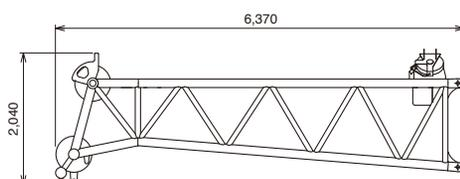

幅 1,060

● ジブトップ台車 0.4 t

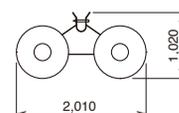

幅 1,550

その他に付属品があります。

搬 送

■ 分解搬送部品

単位(mm)

- エコライザシーブ 1.4 t (置き台付き)
1.1 t (置き台除く)

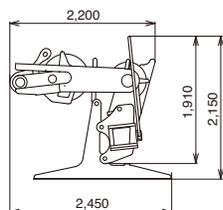

幅 1,630

- マスト3(立組用) 0.9 t

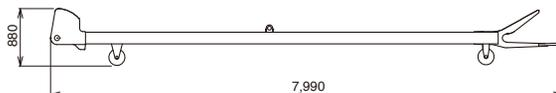

幅 1,460

- ②+⑥ ミドルAジブ + ミドルCジブ 3.7 t

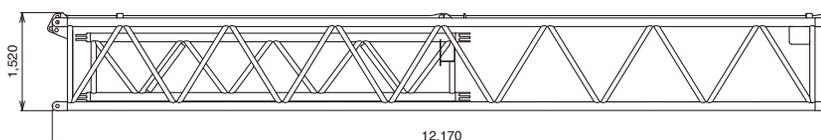

幅 1,840

- ③+⑦ ミドルBジブ + ミドルDジブ 3.6 t

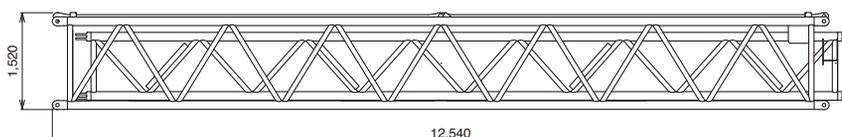

幅 1,840

- 補巻ウインチ+エコライザシーブ 5.9 t

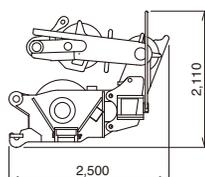

幅 2,210

- 油圧チルトジブ(HLJ)

- ⑨ HLJベースジブ 2.8 t

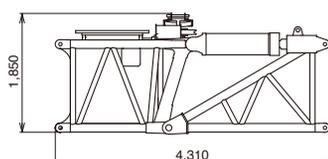

幅 2,040

- ⑩ ヘビートップジブ 0.6 t

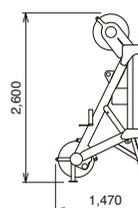

幅 1,730

- 重荷重装置 【重荷重装置付きスペックのみ】

- 重荷重ヘッド 1.5 t

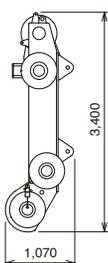

幅 1,330

- シーブサポート 0.8 t

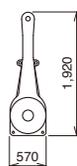

幅 1,120

- バックテンションシーブ 0.7 t

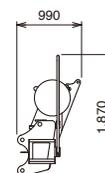

幅 1,550

- アシストジャッキ 0.3 t × 2ヶ



幅 760

- 200tフック+アタッチメントシーブ 3.3 t

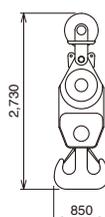

幅 1,220

その他に付属品があります。

設 置

■ アウトリガ張出幅・テールスイング

単位(mm)

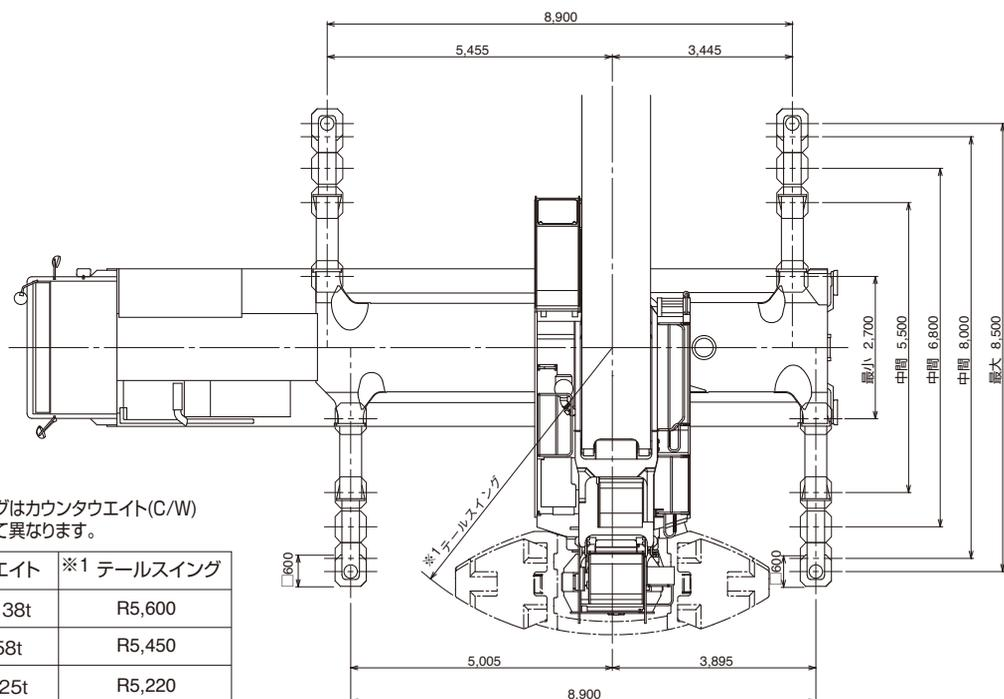
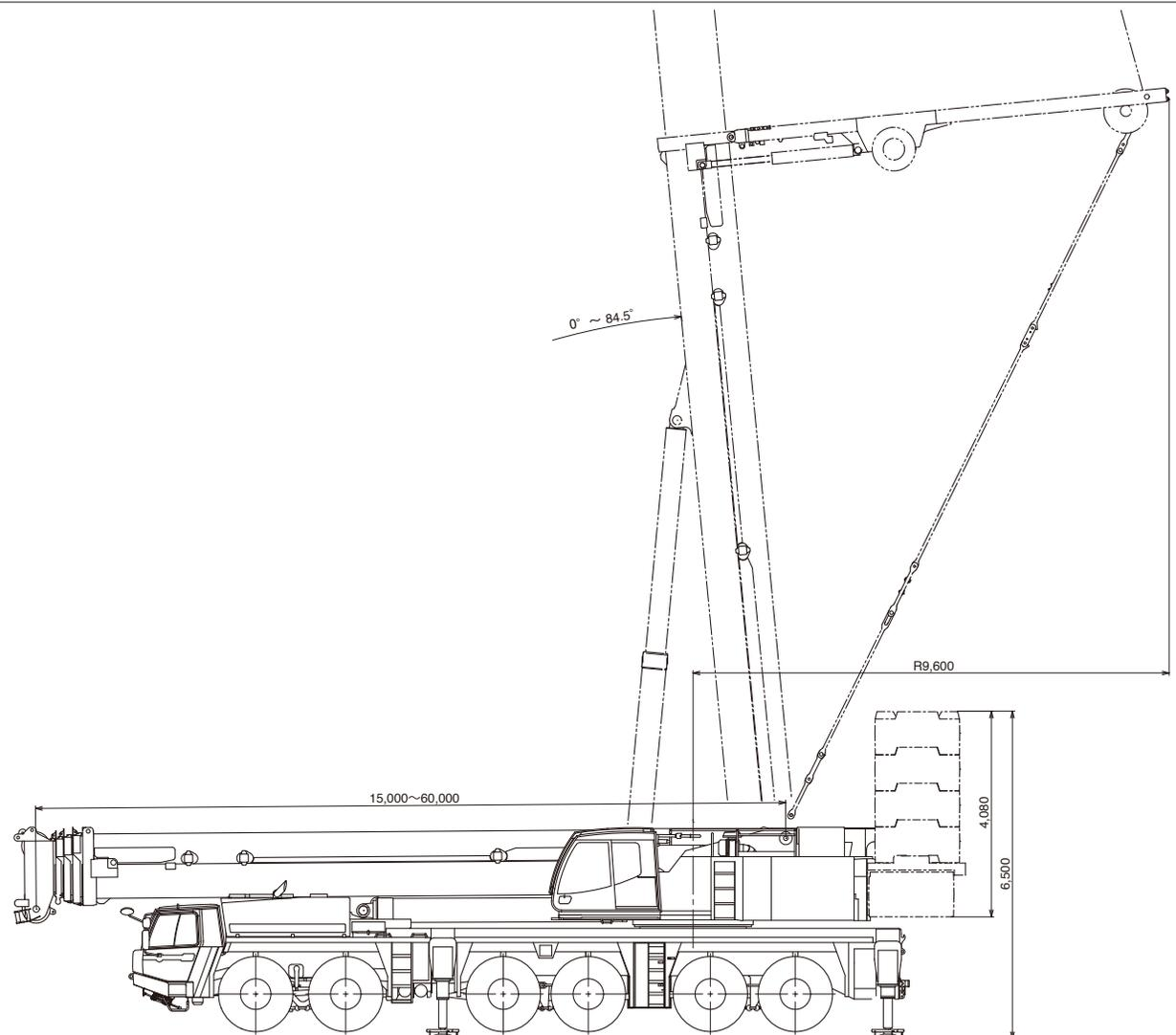

テールスイングはカウンタウエイト(C/W) 組合せによって異なります。

カウンタウエイト	※1 テールスイング
78t ~ 138t	R5,600
47t、58t	R5,450
7.5t ~ 25t	R5,220

設 置

■ フック寸法

単位(mm)

H: ヘッドシーブ中心とハッカ上面の距離

	200tフック	80tフック	35tフック	12.2tフック
ブーム	3.2m	2.7m		
シングルトップ				2.6m
FLJ、LFJ、HLJ、LJ		2.7m	2.6m	2.4m

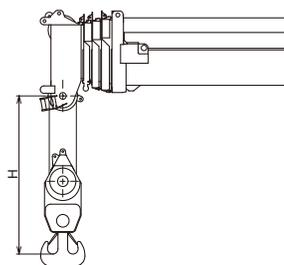

■ カウンタウエイト(C/W)組合せ

● 各ウエイトの使用個数を示す

合計重量	ウエイト① 7.5 t	ウエイト② 9 t	ウエイト③ 8.5 t	ウエイト④ 11 t	ウエイト⑤ 11 t	ウエイト⑥ 10 t
138 t	1	1	1	2	1	8
118 t	1	1	1	2	1	6
98 t	1	1	1	2	1	4
78 t	1	1	1	2	1	2
58 t	1	1	1	2	1	
47 t	1	1	1	2		
25 t	1	1	1			
16.5 t	1	1				
7.5 t	1					
0 t						

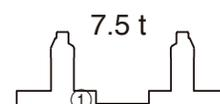
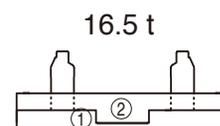
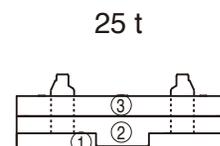
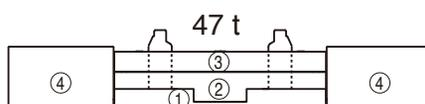
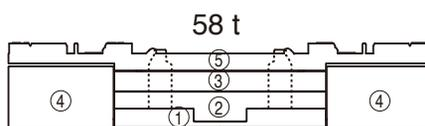
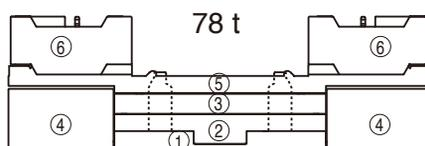
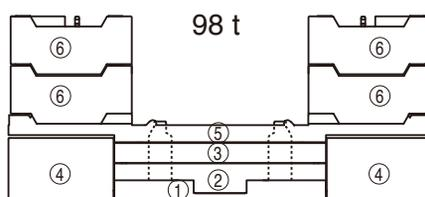
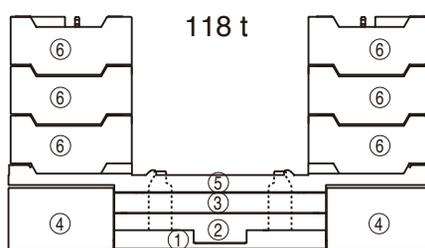
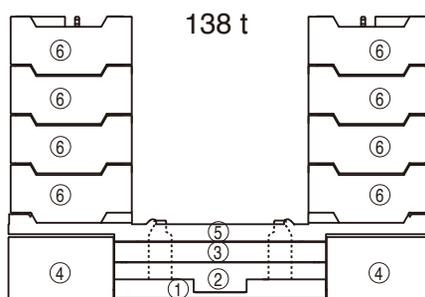

ブーム

ブーム作業半径－揚程図

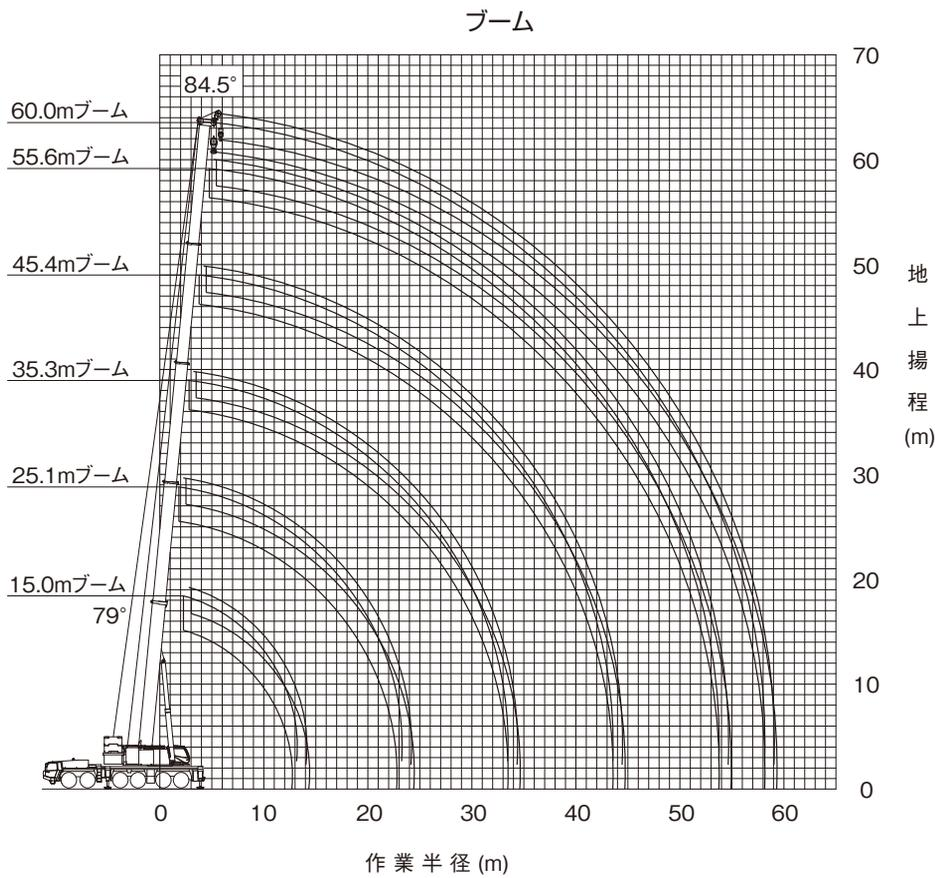

(注意)

- ◆ 上図はブームのたわみを含んでいません。
- ◆ カウンタウエイト98t、アウトリガ張出幅8.5mの性能を図示しています。

ブーム定格総荷重表

■ 定格総荷重表注意事項

◆性能設定のあるカウンタウエイトとアウトリガ張出幅の組合せを、下表に○印で示します。

アウトリガ張出幅 カウンタウエイト	138 t	118 t	98 t	78 t	58 t	47 t	25 t	16.5 t	7.5 t	0 t
8.5 m	○	○	○	○	○	○	○	○	○	○
8.0 m		○	○	○	○	○	○	○	○	○
6.8 m			○	○	○	○	○	○	○	○
5.5 m				○	○	○	○	○	○	○
2.7 m										○

・同じブーム長さでも、ブームの伸長状態によって定格総荷重が異なります。

・カウンタウエイト0t、アウトリガ張出幅2.7mの性能は、ブーム長さ15.0～30.2mのみの設定です。

◆定格総荷重は、つり具質量とフック質量(200トンフック:3,200kg、80トンフック:1,550kg、12.2トンフック:440kg)を含んだ値を示します。

◆定格総荷重は、ブームのたわみを含んだ実際の作業半径に基づいています。

◆定格総荷重表中の標準巻掛本数より少ない本数で使用する場合、最大荷重の上限は下表のとおりです。

巻掛本数	18本	17本	16本	14本	13本	12本	11本	10本	9本	8本	7本	6本
最大荷重	186.1t	177.5t	168.6t	150.4t	141.0t	131.4t	121.6t	111.7t	101.5t	91.1t	80.5t	69.7t

巻掛本数	5本	4本	3本	1本
最大荷重	58.6t	47.4t	35.9t	12.2t

◆シングルトップ使用時の巻掛本数は1本(12.2トンフック使用)で、定格総荷重はブームの定格総荷重からブームに取り付けられているフックの質量を差し引いた値とし、かつ上限は12.2tです。

◆定格総荷重はアウトリガを水平堅土上に設置したときの値です。

◆定格総荷重表は、風による影響を含んでいません。瞬間最大風速が10m/s以上の風速では、クレーン作業を中止してください。

定格総荷重表中の線、および用語説明

◆太線より上側はクレーンの強度に、下側はクレーンの安定に基づいています。

◆「ピン無最大荷重」は、Bピン(ブーム固定ピン)を挿入していないときの定格総荷重の上限を示します。

◆「 θ° 」は、無負荷状態で作動可能なブーム起伏角度範囲を示します。

◆「補巻時・標準巻掛本数」は、補巻使用時の標準巻掛本数を示します。

◆「主巻時・標準巻掛本数」は、主巻使用時の標準巻掛本数を示し、補巻よりもワイヤロープ長さが短い場合、巻掛本数が少なくなる場合があります。

◆「主巻時・最大荷重」は、主巻使用時の定格総荷重の上限を示します。

ブーム

カウンタウエイト 138t、アウトリガ張出幅 8.5m

ブーム

性能ブロック	1	1	3	1	3	5	4	2	1	4	2	1	4	6	2	1	2	1	7	9	8	1	10	11	1	1	12		
性能番号	1	1	14	2	15	19	16	10	3	17	11	4	18	20	12	5	13	6	21	23	22	7	24	25	8	9	26		
ブーム長さ(m)	※15.0		15.0	20.1			25.1						30.2			35.3			40.4			45.4				50.5		55.6	60.0
作業半径(m)	※15.0		15.0	20.1			25.1						30.2			35.3			40.4			45.4				50.5		55.6	60.0
2.7	400.0																												
3.0	360.0																												
3.5	307.0																												
4.0	264.6																												
4.5	230.0																												
6.0	164.5																												
7.0	147.7	147.4	90.5																										
8.0	133.7	133.3	83.8	132.6	123.2	109.3	80.9	58.9																					
9.0	0	121.0	120.7	78.1	120.0	114.5	100.9	74.5	54.3	109.9	81.4	51.1	82.1	82.3	86.4	45.7													
10.0	0	110.4	110.0	73.2	109.3	107.0	93.6	69.1	50.3	102.7	76.0	47.3	75.4	75.6	81.1	42.2	72.4	45.3	64.9	65.6	57.2	47.2	54.3	54.1	48.7	45.0	34.5		
11.0	0	101.3	100.9	68.8	100.1	100.5	87.4	64.5	46.9	96.4	71.3	44.0	69.6	69.9	76.4	39.1	67.0	42.3	60.9	62.3	53.9	44.3	54.0	54.1	45.9	45.0	34.5		
12.0	0	87.8	93.0	64.9	92.2	92.9	81.9	60.4	43.8	90.8	67.2	41.1	64.7	64.9	72.3	36.5	62.3	39.6	57.4	59.3	51.0	41.7	50.9	51.0	43.4	44.5	34.5		
14.0	0	80.1	58.4	79.2	80.0	72.9	53.7	38.5	80.1	60.2	36.3	56.4	56.7	65.3	32.1	54.5	35.2	51.4	52.5	46.0	37.3	45.5	45.7	39.0	40.4	34.5			
16.0	0	67.5	53.4	69.1	69.8	65.7	48.4	34.3	70.0	54.6	32.5	50.0	50.3	59.5	28.6	48.3	31.6	46.4	46.6	41.9	33.7	41.1	41.3	35.5	36.9	31.3			
18.0	0	42.5	44.0	61.0	61.7	59.9	44.1	31.0	61.8	50.0	29.4	44.7	45.0	54.8	25.8	43.3	28.7	41.6	41.8	38.5	30.6	37.5	37.7	32.5	33.9	28.9			
20.0	0	53.1	53.8	54.7	40.6	28.3	55.0	46.2	26.9	40.4	40.7	50.8	50.8	23.5	39.1	26.2	37.4	37.8	35.6	27.8	34.4	34.7	29.9	31.4	26.5				
22.0	0	41.1	41.7	42.6	37.9	26.2	49.3	43.0	24.8	36.7	37.1	47.4	21.5	35.5	24.1	33.7	34.1	33.1	25.5	31.8	32.0	27.5	29.0	24.8					
24.0	0	36.6	38.1	21.6	36.6	24.0	44.2	40.3	23.0	33.4	33.9	44.4	19.8	32.3	22.4	30.5	30.9	31.0	23.5	29.5	29.8	25.4	27.0	23.3					
26.0	0	24.0	25.7	20.4	24.0	25.7	20.4	28.0	28.5	37.9	17.2	27.1	19.5	25.5	25.9	26.3	20.0	24.8	25.1	22.0	23.5	21.1	20.2						
28.0	0	25.9	26.4	32.7	16.1	25.0	18.3	23.4	23.8	24.3	18.4	22.8	23.1	17.3	21.7	22.0	22.5	17.1	21.0	21.3	19.4	20.8	18.9						
30.0	0	23.9	24.3	25.7	15.3	21.5	16.4	20.1	20.4	20.9	15.9	19.4	19.8	18.3	19.3	17.8													
32.0	0	20.1	15.6	18.6	19.0	19.5	14.9	18.1	18.4	17.1	17.9	16.7																	
34.0	0	15.5	15.0	17.4	17.8	18.2	14.0	16.8	17.1	16.1	16.7	15.5																	
36.0	0	16.3	16.6	17.1	13.1	15.7	16.0	15.2	15.6	14.5																			
38.0	0	15.3	15.7	16.1	12.4	14.7	15.0	14.3	14.6	13.6																			
40.0	0	13.8	14.1	13.5	13.7	12.7																							
42.0	0	12.9	13.3	12.9	12.8	11.9																							
44.0	0	11.0	11.2	12.1	12.1	11.2																							
46.0	0	11.4	10.6																										
48.0	0	10.8	10.0																										
50.0	0	9.4																											
52.0	0	8.9																											
54.0	0	5.8																											
56.0	0																												
58.0	0																												
ピン無最大荷重	-	60.0	63.0	69.0	59.0	63.0	66.0	44.0	59.0	63.0	51.1	49.0	59.0	44.0	48.0	45.3	49.0	47.2	48.0	48.7	45.0	34.5							
θ(°)	0~79	0~65	0~70	0~73	0~74	0~77	0~78	0~80	0~81	3~82	3~83																		

※印は重荷重装置付き、後方限定の値です。

カウンタウエイト 118t、アウトリガ張出幅 8.5m

ブーム

性能ブロック	1	3	1	3	5	4	2	1	4	2	1	4	6	2	1	2	1	7	9	8	1	10	11	1	1	12		
性能番号	1	14	2	15	19	16	10	3	17	11	4	18	20	12	5	13	6	21	23	22	7	24	25	8	9	26		
ブーム長さ(m)	15.0		20.1			25.1						30.2			35.3			40.4			45.4				50.5		55.6	60.0
作業半径(m)	15.0		20.1			25.1						30.2			35.3			40.4			45.4				50.5		55.6	60.0
3.0	200.0	170.0	134.8																									
3.5	200.0	170.0	127.0	162.0	139.0	139.0	130.9	95.4																				
4.0	200.0	170.0	119.9	162.0	139.0	139.0	122.5	89.2	139.0	126.8	85.4																	
4.5	195.5	170.0	113.7	162.0	139.0	139.0	115.0	83.8	139.0	120.1	80.1																	
5.0	183.2	170.0	108.1	162.0	139.0	139.0	108.5	79.0	139.0	114.0	75.4	123.3	123.4	113.1	68.0													
6.0	162.6	162.4	98.5	161.9	139.0	131.3	97.4	70.9	139.0	103.6	67.4	110.9	111.1	107.6	60.7	84.2	63.3											
7.0	145.0	144.6	90.5	144.0	133.4	119.3	88.3	64.4	127.9	95.0	60.9	99.4	99.7	99.4	54.7	84.2	57.6	71.6	71.4	68.0	57.4							
8.0	130.0	129.6	83.8	128.9	123.2	109.3	80.9	58.9	118.2	87.6	55.6	90.0	90.2	92.5	49.8	84.2	52.9	71.6	71.4	65.1	54.4	54.3	54.1	48.8				
9.0	117.5	117.1	78.1	116.4	114.5	100.9	74.5	54.3	109.9	81.4	51.1	82.1	82.3	86.4	45.7	78.7	48.8	69.4	69.4	60.9	50.6	54.3	54.1	48.8	45.0			
10.0	107.0	106.6	73.2	105.9	106.6	93.6	69.1	50.3	102.7	76.0	47.3	75.4	75.6	81.1	42.2	72.4	45.3	64.9	65.6	57.2	47.2	54.3	54.1	48.7	45.0	34.5		
11.0	98.1	97.6	68.5	96.9	97.6	87.4	64.5	46.9	96.4	71.3	44.0	69.6	69.9	76.4	39.1	67.0	42.3	60.9	62.3	53.9	44.3	54.0	54.1	45.9	45.0	34.5		
12.0	87.8	89.9	64.9	89.1	89.8	81.9	60.4	43.8	90.0	67.2	41.1	64.7	64.9	72.3	36.5	62.3	39.6	57.4	59.3	51.0	41.7	50.9	51.0	43.4	44.5	34.5		
14.0	0	77.2	58.4	76.3	77.1	72.9	53.7	38.5	77.3	60.2	36.3	56.4	56.7	65.3	32.1	54.5	39.2	51.4	52.5	46.0	37.3	45.5	45.7	39.0	40.4	34.5		
16.0	0	66.9	53.4	65.9	66.7	65.7	48.4	34.3	66.9	54.6	32.5	50.0	50.3	59.5	28.6	48.3	31.6	46.4	46.6	41.9	33.7	41.1	41.3	35.5	36.9	31.3		
18.0	0	42.5	44.0	57.7	58.5	59.4	44.1	31.0	58.6	50.0	29.4	44.7	45.0	54.8	25.8	43.3	28.7	41.6	41.8	38.5	30.6	37.5	37.7	32.5	33.9	28.9		
20.0	0	51.1	51.9	52.7	40.6	28.3	51.9	46.2	26.9	40.4	40.7	50.8	23.5	39.1	26.2	37.4	37.8	35.6	27.8	34.4	34.7	29.9	31.4	26.5				
22.0	0	41.1	41.7	42.6	37.9	26.2	45.9	43.0	24.8	36.7	37.1	47.0	21.5	35.5	24.1	33.7	34.1	33.1	25.5	31.8	32.0	27.5	29.0	24.8				
24.0	0	40.5	40.3	23.0	33.4	33.9	41.5	19.8	32.3	22.4	30.5	30.9	31.0	23.5	29.5	29.8	25.4	27.0	27.4	23.6	25.1	22.1	20.2					
26.0	0	36.2	38.1	21.6	36.6	24.0	44.2	40.3	23.0	33.4	33.9	44.4	19.8	32.3	22.4	30.5	30.9	31.0										

カウンタウエイト 118t、アウトリガ張出幅 8.0m

ブーム

単位:t

Table with columns for performance block, boom length, and boom radius, and rows for boom length (3.5m to 58.0m) and other specifications like maximum weight and angle.

カウンタウエイト 98t、アウトリガ張出幅 8.5m

ブーム

単位:t

Table with columns for performance block, boom length, and boom radius, and rows for boom length (3.0m to 58.0m) and other specifications like maximum weight and angle.

ブーム

カウンタウエイト 98t、アウトリガ張出幅 8.0m

ブーム

性能ブロック	1	3	1	3	5	4	2	1	4	2	1	4	6	2	1	2	1	7	9	8	1	10	11	1	1	12														
性能番号	1	14	2	15	19	16	10	3	17	11	4	18	20	12	5	13	6	21	23	22	7	24	25	8	9	26														
ブーム長さ(m)	20.1			25.1					30.2				35.3				40.4			45.4			50.5			55.6		60.0												
作業半径(m)	20.1			25.1					30.2				35.3				40.4			45.4			50.5			55.6		60.0												
3.0	200.0	170.0	134.8	162.0	139.0	139.0	139.0	102.4																																
3.5	200.0	170.0	127.0	162.0	139.0	139.0	130.9	95.4																																
4.0	200.0	170.0	119.9	162.0	139.0	139.0	122.5	89.2	139.0	126.8	85.4																													
4.5	192.9	170.0	113.7	162.0	139.0	139.0	115.0	83.8	139.0	120.1	80.1																													
5.0	179.3	170.0	108.1	162.0	139.0	139.0	108.5	79.0	139.0	114.0	75.4	123.3	123.4	113.1	68.0																									
6.0	156.7	156.3	98.5	155.7	139.0	131.3	97.4	70.9	139.0	103.6	67.4	110.9	111.1	107.6	60.7	84.2	63.3																							
7.0	138.7	138.3	90.5	137.5	133.4	119.3	88.3	64.4	127.9	95.0	60.9	99.4	99.7	99.4	54.7	84.2	57.6	71.6	71.4	65.1	54.4																			
8.0	123.8	123.5	83.8	122.8	123.2	109.3	80.9	58.9	118.2	87.6	55.6	90.0	90.2	92.5	49.8	84.2	52.9	71.6	71.4	65.1	54.4	54.3	54.1	48.8																
9.0	111.8	111.3	78.1	110.5	111.2	100.9	74.5	54.3	109.9	81.4	51.1	82.1	82.3	86.4	45.7	78.7	48.8	69.4	69.4	60.9	50.6	54.3	54.1	48.8	45.0															
10.0	101.4	101.0	73.2	100.3	101.0	93.6	69.1	50.3	101.2	76.0	47.3	75.4	75.6	81.1	42.2	72.4	45.3	64.9	65.6	57.2	47.2	54.3	54.1	48.7	45.0	34.5														
11.0	92.5	92.1	68.8	91.3	92.0	87.4	64.5	46.9	92.2	71.3	44.0	69.6	69.9	76.4	39.1	67.0	42.3	60.9	62.3	53.9	44.3	54.0	54.1	45.9	45.0	34.5														
12.0	84.7	84.2	64.9	83.3	84.1	81.9	60.4	43.8	84.3	67.2	41.1	64.7	64.9	72.3	36.5	62.3	39.6	57.4	59.3	51.0	41.7	50.9	51.0	43.4	44.5	34.5														
14.0		71.4	58.4	70.5	71.3	72.2	53.7	38.5	71.5	60.2	36.3	56.4	56.7	65.3	32.1	54.5	35.2	51.4	52.5	46.0	37.3	45.5	45.7	39.0	40.4	34.5														
16.0		61.5	53.4	60.5	61.3	62.4	48.4	34.3	61.5	54.6	32.5	50.0	50.3	59.5	28.6	48.3	31.6	46.4	46.6	41.9	33.7	41.1	41.3	35.5	36.9	31.3														
18.0		42.5	44.0	50.4	51.2	52.3	44.1	31.0	51.4	50.0	29.4	44.7	45.0	52.5	25.8	43.3	28.7	41.6	41.8	38.5	30.6	37.5	37.7	32.5	33.9	28.9														
20.0				42.9	43.7	44.7	40.6	28.3	43.8	45.8	26.9	40.4	40.7	44.9	23.5	39.1	26.2	37.4	37.8	35.6	27.8	34.4	34.7	29.9	31.4	26.5														
22.0				37.1	37.9	38.9	37.9	26.2	37.9	39.9	24.8	36.7	37.1	38.9	21.5	35.5	24.1	33.7	34.1	33.1	25.5	31.8	32.0	27.5	29.0	24.8														
24.0									33.2	35.2	23.0	32.3	32.7	34.2	19.8	32.3	22.4	30.5	30.9	31.0	23.5	29.5	29.8	25.4	27.0	23.3														
26.0									29.4	31.4	21.6	28.4	28.9	30.4	18.4	29.5	20.8	27.8	28.2	28.7	21.7	27.0	27.4	23.6	25.1	22.1														
28.0									24.0	25.7	20.4	25.3	25.7	27.2	17.2	26.4	19.5	25.5	25.9	26.3	20.0	24.8	25.1	22.0	23.5	21.1														
30.0																22.6	23.1	24.5	16.1	23.7	18.3	23.4	23.8	24.3	18.4	22.8	21.1	20.2												
32.0																20.4	20.8	22.3	15.3	21.4	17.3	21.4	21.7	22.1	17.1	21.0	21.3	19.4	20.8	18.9										
34.0																						19.4	16.4	19.4	19.7	20.1	15.9	19.4	19.8	18.3	19.3	17.8								
36.0																						17.7	15.6	17.6	17.9	18.3	14.9	18.0	18.3	17.1	17.9	16.7								
38.0																						15.5	15.0	16.1	16.4	16.8	14.0	16.5	16.7	16.1	16.7	15.5								
40.0																											14.7	15.1	15.4	13.1	15.1	15.4	15.2	15.6	14.5					
42.0																											13.6	13.9	14.3	12.4	13.9	14.1	14.3	14.4	13.6					
44.0																																			12.8	13.0	13.3	12.7		
46.0																																			11.8	12.1	12.9	12.3	11.9	
48.0																																			10.9	11.2	12.1	11.4	11.2	
50.0																																				10.6	10.6	10.6	9.9	9.8
52.0																																				9.9	9.1	9.1	8.4	8.4
54.0																																				8.4	8.4	8.4	5.8	5.8
56.0																																								
58.0																																								
ビン無最大荷重	60.0	63.0	69.0		59.0	63.0	66.0	44.0	59.0	63.0	66.0		49.0	59.0	44.0	48.0	61.0		49.0		53.0		48.0	48.8	45.0	34.5														
θ(°)	0~79	0~84.5			0~84.5				0~84.5					0~84.5			0~84.5		0~84.5			0~84.5				3~84.5	3~84.5													
伸長状態(伸長割合%)																																								
伸縮ブーム1	0	0	0	45	45	0	0	0	45	0	0	90	90	45	0	90	0	90	90	90	0	90	90	45	90	100														
伸縮ブーム2	0	45	0	45	0	45	0	0	45	45	0	45	45	45	0	45	45	90	90	45	90	90	45	90	90	90	100													
伸縮ブーム3	0	0	0	0	45	45	45	0	45	45	45	45	0	45	90	45	90	45	90	45	90	45	90	90	45	90	100													
伸縮ブーム4	0	0	45	0	0	0	45	90	0	45	90	0	45	45	90	45	90	45	90	45	90	90	45	90	90	90	100													
標準フック	200t	200t			200t				200t						200t			80t	200t	80t																				
フック重量	3200kg	3200kg			3200kg				3200kg						3200kg			1550kg	3200kg	1550kg																				
補巻時標準巻掛本数	20	17	13	16		13	10		13	12	8		12	11	6	8	6	7	6	5		5																		
主巻時標準巻掛本数	18	13			11		10		9	8		8		6	6		6		6		5		5																	
主巻時最大荷重	186.1	141.0	134.8		121.6		102.4		101.5	85.4		91.1		68.0	69.7	63.3		69.7	68.0	57.4		54.3	54.1	48.8	45.0	34.5														

カウンタウエイト 78t、アウトリガ張出幅 8.5m

ブーム

性能ブロック	1	3	1	3	5	4	2	1	4	2	1	4	6	2	1	2	1	7	9	8	1	10	11	1	1	12			
性能番号	1	14	2	15	19	16	10	3	17	11	4	18	20	12	5	13	6	21	23	22	7	24	25	8	9	26			
ブーム長さ(m)	20.1			25.1					30.2				35.3				40.4			45.4			50.5			55.6		60.0	
作業半径(m)	20.1			25.1					30.2				35.3				40.4			45.4			50.5			55.6		60.0	
3.0	200.0	170.0	134.8	162.0	139.0	139.0	139.0	102.4																					
3.5	200.0	170.0	127.0	162.0	139.0	139.0	130.9	95.4																					
4.0	200.0	170.0	119.9	162.0	139.0	139.0	122.5	89.2	139.0	126.8	85.4																		
4.5	190.0	170.0	113.7	162.0	139.0	139.0	115.0	83.8	139.0	120.1	80.1																		
5.0	176.6	170.0	108.1	162.0	139.0	139.0	108.5	79.0	139.0	114.0	75.4	123.3	123.4	113.1	68.0														
6.0	154.1	153.7	98.5	153.1	139.0																								

カウンタウエイト 78t、アウトリガ張出幅 8.0m

ブーム

単位:t

Table with columns for performance block, boom length, boom radius, and various weight and length specifications. Includes sub-tables for extension ratios and standard hook weights.

カウンタウエイト 78t、アウトリガ張出幅 6.8m

ブーム

単位:t

Table with columns for performance block, boom length, boom radius, and various weight and length specifications. Includes sub-tables for extension ratios and standard hook weights.

ブーム

カウンタウエイト 58t、アウトリガ張出幅 8.5m

ブーム

性能ブロック	1	3	1	3	5	4	2	1	4	2	1	4	6	2	1	2	1	7	9	8	1	10	11	1	1	12	単位.t								
性能番号	1	14	2	15	19	16	10	3	17	11	4	18	20	12	5	13	6	21	23	22	7	24	25	8	9	26									
ブーム長さ(m)	15.0			20.1			25.1			30.2			35.3			40.4			45.4			50.5			55.6		60.0								
作業半径(m)	15.0			20.1			25.1			30.2			35.3			40.4			45.4			50.5			55.6		60.0								
3.0	200.0	170.0	134.8	162.0	139.0	139.0	139.0	102.4																											
3.5	200.0	170.0	127.0	162.0	139.0	139.0	130.9	95.4																											
4.0	199.6	170.0	119.9	162.0	139.0	139.0	122.5	89.2	139.0	126.8	85.4																								
4.5	184.4	170.0	113.7	162.0	139.0	139.0	115.0	83.8	139.0	120.1	80.1																								
5.0	171.1	170.0	108.1	162.0	139.0	139.0	108.5	79.0	139.0	114.0	75.4	123.3	123.4	113.1	68.0																				
6.0	148.8	148.4	98.5	147.8	139.0	131.3	97.4	70.9	139.0	103.6	67.4	110.9	111.1	107.6	60.7	84.2	63.3																		
7.0	130.5	130.0	90.5	129.3	130.0	119.3	88.3	64.4	127.9	95.0	60.9	99.4	99.7	99.4	54.7	84.2	57.6	71.6	71.4	65.1	54.4														
8.0	114.9	114.5	83.8	113.7	114.5	109.3	80.9	58.9	114.7	87.6	55.6	90.0	90.2	92.5	49.8	84.2	52.9	71.6	71.4	65.1	54.4	54.3	54.1	48.8											
9.0	102.3	101.9	78.1	101.1	101.8	100.9	74.5	54.3	102.1	81.4	51.1	82.1	82.3	86.4	45.7	78.7	48.8	69.4	69.4	60.9	50.6	54.3	54.1	48.8	45.0										
10.0	91.0	90.5	73.2	89.5	90.4	91.6	69.1	50.3	90.7	76.0	47.3	75.4	75.6	81.1	42.2	72.4	45.3	64.9	65.6	57.2	47.2	54.3	54.1	48.7	45.0	34.5									
11.0	77.9	77.3	68.8	76.2	77.2	78.4	64.5	46.9	77.5	71.3	44.0	69.6	69.9	76.4	39.1	67.0	42.3	60.9	62.3	53.9	44.3	54.0	54.1	45.9	45.0	34.5									
12.0	67.4	66.8	64.9	65.8	66.7	67.9	60.4	43.8	67.0	67.2	41.1	64.7	64.9	68.4	36.5	62.3	39.6	57.4	59.3	51.0	41.7	50.9	51.0	43.4	44.5	34.5									
14.0		52.0	54.0	51.0	51.9	53.0	53.7	38.5	52.1	54.3	36.3	51.2	51.7	53.4	32.1	52.8	35.2	51.4	52.5	46.0	37.3	45.5	45.7	39.0	40.4	34.5									
16.0		42.1	44.0	41.1	41.9	43.0	44.5	34.3	42.1	44.2	32.5	41.2	41.7	43.3	28.6	42.7	31.6	42.8	43.2	41.9	33.7	41.1	41.3	35.5	36.9	31.3	26.5								
18.0		35.2	37.0	34.0	34.8	35.8	37.2	31.0	34.9	36.9	29.4	34.0	34.5	36.1	25.8	35.4	28.7	35.5	35.9	36.3	30.6	36.0	36.0	36.4	32.5	33.9	28.9								
20.0				28.6	29.4	30.4	31.8	28.3	29.4	31.5	26.9	28.5	29.0	30.6	23.5	29.9	26.2	30.0	30.4	30.8	27.8	30.5	30.8	29.9	31.3	26.5									
22.0				24.3	25.2	26.1	27.6	26.2	25.1	27.1	24.8	24.2	24.6	26.2	21.5	25.5	24.1	25.6	25.9	26.4	25.5	26.1	26.4	27.5	26.8	24.8									
24.0									21.7	23.6	23.0	20.7	21.1	22.7	19.8	22.0	22.4	22.0	22.4	22.8	23.5	22.5	22.8	23.9	23.3	23.3									
26.0									18.9	20.9	21.6	17.9	18.3	19.8	18.4	19.1	20.8	19.2	19.5	19.9	21.4	19.6	20.0	21.0	20.3	20.5									
28.0									16.7	18.7	19.8	15.6	16.0	17.5	17.2	16.7	19.4	16.8	17.1	17.5	19.0	17.2	17.5	18.6	17.9	18.1									
30.0												13.7	14.1	15.6	16.1	14.7	17.4	14.8	15.1	15.5	16.9	15.2	15.5	16.5	15.9	16.0									
32.0													12.1	12.5	14.0		15.3	13.0	15.7	13.1	13.4	13.8	15.2	13.5	13.8	14.8	14.2	14.3							
34.0																					11.6	14.2	11.6	11.9	12.3	13.7	12.0	12.3	13.3	12.6	12.8				
36.0																					10.4	13.0	10.3	10.6	11.0	12.4	10.7	11.0	12.0	11.3	11.4				
38.0																					9.2	11.9	9.1	9.5	9.9	11.3	9.6	9.9	10.8	10.2	10.3				
40.0																					8.0	8.4	8.9	10.3	8.4	8.8	9.8	9.2	9.3						
42.0																					7.0	7.4	7.9	9.5	7.4	7.8	8.9	8.2	8.2						
44.0																								6.5	6.9	8.1	7.2	7.3							
46.0																								5.7	6.1	7.3	6.4	6.5							
48.0																								5.1	5.4	6.6	5.7	5.7							
50.0																																			
52.0																																			
54.0																																			
56.0																																			
58.0																																			
ビン無最大荷重	60.0	63.0	69.0		59.0	63.0	66.0	44.0	59.0	63.0	66.0		49.0	59.0	44.0	48.0	61.0		49.0		53.0	48.0	48.8	45.0	34.5										
θ(°)	0~79		0~84.5		0~84.5		0~84.5		0~84.5		0~84.5		0~84.5		0~84.5		0~84.5		0~84.5		0~84.5		0~84.5		3~84.5	3~84.5									
伸長状態(伸長割合%)																																			
伸縮ブーム1	0	0	0	45	45	0	0	0	45	0	0	90	90	45	0	90	0	90	90	90	0	90	90	45	90	100									
伸縮ブーム2	0	45	0	45	0	45	0	0	45	45	0	45	45	45	0	45	45	90	90	45	90	90	45	90	90	90	100								
伸縮ブーム3	0	0	0	0	45	45	45	0	45	45	45	45	0	45	90	45	90	45	90	45	90	90	45	90	90	100									
伸縮ブーム4	0	0	45	0	0	0	45	90	0	45	90	0	45	45	90	45	90	45	90	45	90	90	45	90	90	100									
標準フック	200t	200t		200t		200t		200t		200t		200t		200t		80t	200t	80t		80t		80t		80t		80t	80t								
フック重量	3200kg	3200kg		3200kg		3200kg		3200kg		3200kg		3200kg		3200kg		1550kg	3200kg	1550kg		1550kg		1550kg		1550kg		1550kg	1550kg								
補巻時標準巻掛本数	20	17	13	16		13		10	13	12	8		12	11	6	8	6		7	6	5		5		4	3									
主巻時標準巻掛本数	18		13		11		10		9		8		8		6		6		6		5		5		4	3									
主巻時最大荷重	186.1	141.0	134.8		121.6		102.4		101.5		85.4		91.1		68.0		69.7		63.3		69.7		68.0		57.4		54.3		54.1		48.8		45.0		34.5

カウンタウエイト 58t、アウトリガ張出幅 8.0m

ブーム

性能ブロック	1	3	1	3	5	4	2	1	4	2	1	4	6	2	1	2	1	7	9	8	1	10	11	1	1	12	単位.t				
性能番号	1	14	2	15	19	16	10	3	17	11	4	18	20	12	5	13	6	21	23	22	7	24	25	8	9	26					
ブーム長さ(m)	15.0			20.1			25.1			30.2			35.3			40.4			45.4			50.5			55.6		60.0				
作業半径(m)	15.0			20.1			25.1			30.2			35.3			40.4			45.4			50.5			55.6		60.0				
3.0	200.0	170.0	134.8	162.0	139.0	139.0	139.0	102.4																							
3.5	200.0	170.0	127.0	162.0	139.0	139.0	130.9	95.4																							
4.0	196.8	170.0	119.9	162.0	139.0	139.0	122.5	89.2	139.0	126.8	85.4																				
4.5	181.6	170.0	113.7	162.0	139.0	139.0	115.0	83.8	139.0	120.1	80.1																				
5.0	168.2	167.8	108.1	162.0	139.0	139.0	108.5	79.0	139.0	114.0	75.4	123.3	123.4	113.1	68.0																
6.0	146.0	145.6	98.5	145.0	139.0	131.3	97.4	70.9	139.0	103.6	67.4	110.9	111.1	107.6	60.7	84.2	63.3														
7.0	127.9	127.4	90.5	126.7	127.4	11																									

カウンタウエイト 58t、アウトリガ張出幅 6.8m

ブーム

単位:t

性能ブロック	1	3	1	3	5	4	2	1	4	2	1	4	6	2	1	2	1	7	9	8	1	10	11	1	1	12			
性能番号	1	14	2	15	19	16	10	3	17	11	4	18	20	12	5	13	6	21	23	22	7	24	25	8	9	26			
ブーム長さ(m)	15.0	20.1		25.1					30.2				35.3				40.4			45.4				50.5			55.6		60.0
作業半径(m)	3.0	200.0	170.0	134.8	162.0	139.0	139.0	102.4																					
3.5	200.0	170.0	127.0	162.0	139.0	139.0	130.9	95.4																					
4.0	188.5	170.0	119.9	162.0	139.0	139.0	122.5	89.2	139.0	126.8	85.4																		
4.5	173.4	170.0	113.7	162.0	139.0	139.0	115.0	83.8	139.0	120.1	80.1																		
5.0	160.1	159.8	108.1	159.1	139.0	139.0	108.5	79.0	139.0	114.0	75.4	123.3	123.4	113.1	68.0														
6.0	138.4	138.0	98.5	137.3	138.0	131.3	97.4	70.9	138.2	103.6	67.4	110.9	111.1	107.6	60.7	84.2	63.3												
7.0	120.6	120.2	90.5	119.4	120.2	119.3	88.3	64.4	120.4	95.0	60.9	99.4	99.7	99.4	54.7	84.2	57.6	71.6	71.4	68.0	57.4								
8.0	105.8	105.4	83.8	104.6	105.3	106.3	80.9	58.9	105.6	87.6	55.6	90.0	90.2	92.5	49.8	84.2	52.9	71.6	71.4	65.1	54.4	54.3	54.1	48.8					
9.0	86.9	86.3	78.1	85.1	86.2	87.5	74.5	54.3	86.5	81.4	51.1	82.1	82.3	86.4	45.7	78.7	48.8	69.4	69.4	60.9	50.6	54.3	54.1	48.8	45.0				
10.0	72.2	71.7	73.2	70.6	71.6	72.8	68.1	50.3	71.9	74.4	47.3	70.9	71.4	73.4	42.2	72.4	45.3	64.9	65.6	57.2	47.2	54.3	54.1	48.7	45.0	34.5			
11.0	61.5	60.9	63.0	59.9	60.9	62.0	63.7	46.9	61.1	63.5	44.0	60.1	60.7	62.6	39.1	61.9	42.3	60.9	62.3	53.9	44.3	54.0	54.1	45.9	45.0	34.5			
12.0	53.3	52.7	54.7	51.7	52.6	53.8	55.4	43.8	52.9	55.2	41.1	51.9	52.4	54.2	36.5	53.6	39.6	53.7	54.1	51.0	41.7	50.9	51.0	43.4	44.5	34.5			
14.0		41.0	42.9	40.0	40.8	41.9	43.4	38.5	41.1	43.2	36.3	40.1	40.6	42.3	32.1	41.7	35.2	41.8	42.2	42.6	37.3	42.4	42.7	39.0	40.4	34.5			
16.0		33.0	34.9	32.0	32.8	33.8	35.3	34.3	33.0	35.1	32.5	32.1	32.6	34.2	28.6	33.6	31.6	33.7	34.0	34.5	33.7	34.2	34.5	35.5	35.0	31.3			
18.0		27.4	29.2	26.3	27.1	28.0	29.5	29.7	27.2	29.2	29.4	26.3	26.7	28.3	25.8	27.7	28.7	27.8	28.1	28.6	30.1	28.3	28.6	29.7	29.0	28.9			
20.0				21.9	22.7	23.7	25.1	25.3	22.8	24.7	25.9	21.9	22.3	23.8	23.5	23.2	26.0	23.3	23.6	24.1	25.5	23.8	24.1	25.2	24.5	24.7			
22.0				18.6	19.4	20.3	21.7	21.9	19.3	21.3	22.4	18.4	18.9	20.4	21.5	19.7	22.4	19.8	20.1	20.5	22.0	20.3	20.6	21.6	21.0	21.1			
24.0									16.6	18.5	19.6	15.7	16.1	17.6	19.4	16.9	19.6	17.0	17.3	17.7	19.1	17.4	17.7	18.8	18.1	18.3			
26.0									14.4	16.3	17.4	13.4	13.8	15.3	17.1	14.6	17.2	14.7	15.0	15.4	16.8	15.1	15.4	16.4	15.8	15.9			
28.0									12.7	14.5	15.6	11.6	12.0	13.4	15.2	12.7	15.3	12.7	13.0	13.4	14.8	13.2	13.4	14.4	13.8	13.9			
30.0												9.8	10.3	11.8	13.6	11.0	13.6	11.1	11.4	11.8	13.2	11.5	11.8	12.8	12.2	12.3			
32.0												8.4	8.9	10.5	12.3	9.6	12.2	9.6	10.0	10.4	11.8	10.1	10.4	11.4	10.7	10.8			
34.0																	8.2	11.0	8.2	8.6	9.1	10.5	8.8	9.1	10.1	9.5	9.6		
36.0																	7.1	10.0	7.1	7.5	8.0	9.5	7.5	7.9	9.0	8.3	8.4		
38.0																	6.1	9.1	6.0	6.4	6.9	8.5	6.5	6.8	8.1	7.2	7.3		
40.0																		5.1	5.5	6.0	7.7	5.5	5.9	7.1	6.3	6.4			
42.0																		4.3	4.7	5.2	6.9	4.7	5.1	6.3	5.4	5.5			
44.0																						4.0	4.3	5.5	4.7	4.7			
46.0																						3.3	3.7	4.9	4.0	4.0			
48.0																						2.8	3.1	4.3	3.4	3.4			
50.0																									2.8	2.8			
ピン無 最大荷重	60.0	63.0	69.0	59.0			63.0	66.0	44.0	59.0	63.0	66.0	49.0		59.0	44.0	48.0	61.0	49.0		53.0	48.0		48.8	45.0	34.5			
θ(°)	0~79	0~84.5		0~84.5				0~84.5				0~84.5				0~84.5			0~84.5				0~84.5		18~84.5	31~84.5			
伸長状態(伸長割合%)																													
伸縮ブーム1	0	0	0	45	45	0	0	0	45	0	0	90	90	45	0	90	0	90	90	90	0	90	90	45	90	100			
伸縮ブーム2	0	45	0	45	0	45	0	0	45	45	0	45	45	45	0	45	45	90	90	45	90	90	90	90	90	100			
伸縮ブーム3	0	0	0	0	45	45	45	0	45	45	45	45	0	45	90	45	90	45	90	45	90	45	90	90	90	100			
伸縮ブーム4	0	0	45	0	0	0	0	45	90	0	45	90	0	45	90	0	45	90	45	90	90	45	90	90	90	100			
標準フック	200t	200t		200t				200t				200t				200t			200t			80t			80t				
フック重量	3200kg	3200kg		3200kg				3200kg				3200kg				1550kg			3200kg			1550kg			1550kg				
補巻時標準 巻掛本数	20	17	13	16	13			10	13	12	8	12	11	6	8	6	7	6	5	5			4	3	3	3			
主巻時標準 巻掛本数	18	13		11				10	9		8	8			6	6	6			5		5		4	3				
主巻時 最大荷重	186.1	141.0	134.8	121.6				102.4	101.5	85.4	91.1			68.0	69.7	63.3	69.7	68.0	57.4	54.3	54.1	48.8	45.0	34.5					

カウンタウエイト 47t、アウトリガ張出幅 8.5m

ブーム

単位:t

性能ブロック	1	3	1	3	5	4	2	1	4	2	1	4	6	2	1	2	1	7	9	8	1	10	11	1	1	12			
性能番号	1	14	2	15	19	16	10	3	17	11	4	18	20	12	5	13	6	21	23	22	7	24	25	8	9	26			
ブーム長さ(m)	15.0	20.1		25.1					30.2				35.3				40.4			45.4				50.5			55.6		60.0
作業半径(m)	3.0	200.0	170.0	134.8	162.0	139.0	139.0	102.4																					
3.5	200.0	170.0	127.0	162.0	139.0	139.0	130.9	95.4																					
4.0	196.4	170.0	119.9	162.0	139.0	139.0	122.5	89.2	139.0	126.8	85.4																		
4.5	181.2	170.0	113.7	162.0	139.0	139.0	115.0	83.8	139.0	120.1	80.1																		
5.0	167.9	167.6	108.1	162.0	139.0	139.0	108.5	79.0	139.0	114.0	75.4	123.3	123.4	113.1	68.0														
6.0	145.5	145.0	98.5	144.3	139.0	131.3	97.4	70.9	139.0	103.6	67.4	110.9	111.1	107.6	60.7	84.2	63.3												
7.0	126.2	125.8	90.5	125.0	125.8	119.3	88.3	64.4	126.0	95.0	60.9	99.4	99.7	99.4	54.7	84.2	57.6	71.6	71.4	65.1	54.4	54.3	54.1	48.8	45.0				
8.0	110.9	110.5	83.8	109.7	110.5	109.3	80.9	58.9	110.7	87.6	55.6	90.0	90.2	92.5	49.8	84.2	52.9	71.6	71.4	65.1	54.4	54.3	54.1	48.8	45.0				
9.0	97.1	96.5	78.1	95.5	96.5	97.7	74.5	54.3	96.8	81.4	51.1	82.1	82.3	86.4	45.7	78.7	48.8	69.4	69.4	60.9	50.6	54.3	54.1	48.8	45.0				
10.0	80.8	80.2	73.2	79.1	80.1	81.4	69.1	50.3	80.4	76.0	47.3	75.4	75.6	81.1	42.2	72.4	45.3	64.9	65.6	57.2	47.2	54.3	54.1	48.7	45.0				
11.0	68.5	67.9	68.8	66.8	67.8	69.0	64.5	46.9	68.1	70.6	44.0	67.1	67.6	69.6	39.1	67.0	42.3	60.9	62.3	53.9	44.3	54.0	54.1	45.9	45.0				
12.0	59.2	58.6	60.7	57.6	58.5	59.6	60.4	43.8	58.8	61.1	41.1	57.7	58.3	60.1	36.5	59.5	39.6	57.4	59.3	51.0	41.7	50.9	51.0	43.4	44.5				
14.0		45.4	47.3	44.4	45.3	46.3	47.9	38.5	45.5	47.7	36.3	44.5	45.0	46.8	32.1	46.1	35.2	46.2	46.6	46.0	37.3	45.5	45.7	39.0	40.4				
16.0		36.4	38.4	35.4	36.2	37.3	38.9	34.3	36.4	3																			

ブーム

カウンタウエイト 16.5t、アウトリガ張出幅 8.0m

ブーム

性能ブロック	1	3	1	3	5	4	2	1	4	2	1	4	6	2	1	2	1	7	9	8	1	10	11	1	1	12		
性能番号	1	14	2	15	19	16	10	3	17	11	4	18	20	12	5	13	6	21	23	22	7	24	25	8	9	26		
ブーム長さ(m)	15.0			20.1			25.1			30.2			35.3			40.4			45.4			50.5			55.6		60.0	
作業半径(m)	15.0			20.1			25.1			30.2			35.3			40.4			45.4			50.5			55.6		60.0	
3.0	200.0	170.0	134.8	162.0	139.0	139.0	139.0	102.4																				
3.5	200.0	170.0	127.0	162.0	139.0	139.0	130.9	95.4																				
4.0	182.7	170.0	119.9	162.0	139.0	139.0	122.5	89.2	139.0	126.8	85.4																	
4.5	166.6	166.2	113.7	162.0	139.0	139.0	115.0	83.8	139.0	120.1	80.1																	
5.0	152.0	151.6	108.1	150.8	139.0	139.0	108.5	79.0	139.0	114.0	75.4	123.3	123.4	113.1	68.0													
6.0	128.3	127.9	98.5	127.1	127.9	128.8	97.4	70.9	128.2	103.6	67.4	110.9	111.1	107.6	60.7	84.2	63.3											
7.0	99.6	98.7	90.5	97.1	98.7	100.6	88.3	64.4	99.2	95.0	60.9	97.6	98.5	99.4	54.7	84.2	57.6	71.6	71.4	68.0	57.4							
8.0	72.2	71.5	74.4	70.1	71.5	73.1	75.5	58.9	71.9	75.2	55.6	70.5	71.3	73.9	49.8	73.0	52.9	71.6	71.4	65.1	54.4	54.3	54.1	48.8				
9.0	55.8	55.2	57.8	54.0	55.1	56.6	58.7	54.3	55.5	58.5	51.1	54.3	55.0	57.3	45.7	56.5	48.8	56.7	57.2	57.9	50.6	54.3	54.1	48.8	45.0			
10.0	44.9	44.3	46.7	43.2	44.3	45.8	47.6	47.8	44.6	47.4	47.3	43.5	44.1	46.2	42.2	45.5	45.3	45.7	46.1	46.7	47.2	46.4	46.8	48.3	45.0	34.5		
11.0	37.2	36.6	38.9	35.5	36.5	37.8	39.6	39.9	36.8	39.4	40.9	35.7	36.3	38.3	39.1	37.6	41.3	37.8	38.2	38.8	40.8	38.5	38.9	40.3	39.5	34.5		
12.0	31.4	30.8	33.0	29.7	30.7	31.9	33.7	33.9	31.0	33.4	34.9	29.9	30.5	32.4	34.8	31.7	35.2	31.9	32.3	32.8	34.7	32.5	32.9	34.3	33.5	33.7		
14.0		22.7	24.7	21.7	22.6	23.7	25.3	25.6	22.8	25.1	26.4	21.8	22.4	24.1	26.4	23.5	26.7	23.6	24.0	24.5	26.2	24.2	24.6	25.8	25.1	25.3		
16.0		17.4	19.3	16.4	17.2	18.3	19.8	20.1	17.4	19.6	20.8	16.5	17.0	18.6	20.9	18.0	21.1	18.1	18.5	18.9	20.6	18.7	19.0	20.2	19.5	19.7		
18.0		13.8	15.7	12.6	13.4	14.4	15.9	16.1	13.5	15.6	16.9	12.6	13.1	14.7	16.8	14.1	17.0	14.2	14.5	15.0	16.6	14.7	15.0	16.2	15.5	15.7		
20.0				9.8	10.6	11.6	13.1	13.3	10.7	12.7	13.9	9.8	10.2	11.8	13.8	11.1	14.0	11.2	11.6	12.0	13.6	11.7	12.1	13.2	12.5	12.7		
22.0				7.4	8.4	9.5	10.9	11.1	8.4	10.5	11.6	7.2	7.8	9.5	11.5	8.9	11.7	8.9	9.3	9.7	11.2	9.4	9.8	10.8	10.2	10.3		
24.0									6.4	8.7	9.8	5.2	5.8	7.7	9.7	6.8	9.8	6.9	7.3	7.9	9.4	7.5	7.9	9.0	8.3	8.5		
26.0									4.9	7.3	8.4	3.6	4.2	6.1	8.2	5.1	8.3	5.2	5.6	6.2	7.8	5.8	6.2	7.4	6.7	6.8		
28.0									3.7	6.1	7.4			4.7	7.0	3.7	7.0	3.8	4.2	4.8	6.5	4.4	4.8	6.0	5.2	5.4		
30.0														3.6	5.9	2.6	5.9	2.6	3.0	3.6	5.3	3.2	3.6	4.8	4.0	4.2		
32.0															5.0					4.9								
34.0																				4.1								
36.0																				3.3								
38.0																				2.8								
ビン無最大荷重	60.0	63.0	69.0	59.0	63.0	66.0	44.0	59.0	63.0	66.0	49.0	59.0	44.0	48.0	61.0	49.0	53.0	48.0	48.8	45.0	34.5							
θ(°)	0~79	0~84.5		0~84.5				0~84.5	35~84.5	19~84.5	0~84.5	36~84.5	0~84.5	45~84.5	41~84.5	32~84.5	51~84.5	48~84.5	45~84.5	53~84.5	60~84.5							
伸長状態(伸長割合%)																												
伸縮ブーム1	0	0	0	45	45	0	0	0	45	0	0	90	90	45	0	90	0	90	90	90	90	0	90	90	45	90	100	
伸縮ブーム2	0	45	0	45	0	45	0	0	45	45	0	45	45	45	0	45	45	90	90	45	90	90	90	90	90	90	100	
伸縮ブーム3	0	0	0	0	45	45	45	0	45	45	45	45	0	45	90	45	90	45	90	45	90	90	90	90	90	90	100	
伸縮ブーム4	0	0	45	0	0	0	45	90	0	45	90	0	45	45	90	45	90	45	90	90	90	90	90	90	90	90	100	
標準フック	200t	200t		200t					200t			200t			80t	200t	80t			80t								
フック重量	3200kg	3200kg		3200kg					3200kg			3200kg			1550kg	3200kg	1550kg			1550kg								
補巻時標準巻掛本数	20	17	13	16		13		10	13	12	8	12	11	6	8	6	6	7	6	5		5		4	3			
主巻時標準巻掛本数	18	13		11			10	9	8		8			6	6		6		6		5		5		4	3		
主巻時最大荷重	186.1	141.0	134.8		121.6		102.4	101.5	85.4		91.1			68.0	69.7	63.3		69.7	68.0	57.4	54.3	54.1	48.8	45.0	34.5			

カウンタウエイト 16.5t、アウトリガ張出幅 6.8m

ブーム

性能ブロック	1	3	1	3	5	4	2	1	4	2	1	4	6	2	1	2	1	7	9	8	1	10	11	1	1	12		
性能番号	1	14	2	15	19	16	10	3	17	11	4	18	20	12	5	13	6	21	23	22	7	24	25	8	9	26		
ブーム長さ(m)	15.0			20.1			25.1			30.2			35.3			40.4			45.4			50.5			55.6		60.0	
作業半径(m)	15.0			20.1			25.1			30.2			35.3			40.4			45.4			50.5			55.6		60.0	
3.0	200.0	170.0	134.8	162.0	139.0	139.0	139.0	102.4																				
3.5	189.5	170.0	127.0	162.0	139.0	139.0	130.9	95.4																				
4.0	172.3	170.0	119.9	162.0	139.0	139.0	122.5	89.2	139.0	126.8	85.4																	
4.5	156.1	155.6	113.7	154.9	139.0	139.0	115.0	83.8	139.0	120.1	80.1																	
5.0	141.9	141.4	108.1	140.7	139.0	139.0	108.5	79.0	139.0	114.0	75.4	123.3	123.4	113.1	68.0													
6.0	102.7	101.9	98.5	100.3	101.8	103.7	97.4	70.9	102.4	103.6	67.4	100.7	101.6	104.7	60.7	84.2	63.3											
7.0	71.4	70.7	73.6	69.4	70.7	72.3	74.6	64.4	71.1	74.4	60.9	69.8	70.5	73.1	54.7	72.3	57.6	71.6	71.4	68.0	57.4							
8.0	53.8	53.2	55.7	52.0	53.1	54.5	56.6	56.9	53.5	56.4	55.6	52.3	53.0	55.2	49.8	54.5	52.9	54.7	55.2	55.8	54.4	54.3	54.1	48.8				
9.0	42.4	41.9	44.2	40.8	41.8	43.1	45.0	45.3	42.2	44.8	46.4	41.1	41.7	43.8	45.7	43.0	46.9	43.2	43.7	44.3	46.3	35.9	36.3	37.7	36.9	34.5		
10.0	34.6	34.0	36.2	33.0	34.0	35.2	37.0	37.2	34.3	36.8	38.2	33.2	33.8	35.8	38.2	35.1	38.6	35.2	35.7	36.2	38.1	30.0	30.4	31.7	30.9	31.1		
11.0	28.8	28.2	30.3	27.2	28.2	29.3	31.0	31.3	28.5	30.8	32.2	27.5	28.0	29.9	32.2	29.2	32.6	29.3	29.8	30.3	32.1	30.0	30.4	31.7	30.9	31.1		
12.0	24.4	23.8	25.8	22.8	23.7	24.9	26.5	26.7	24.0	26.3	27.6	23.0	23.6	25.3	27.6	24.7	28.0	24.8	25.2	25.7	27.5	25.4	25.8	27.0	26.3	26.5		
14.0		17.5	19.4	16.5	17.4	18.5	20.0	20.2	17.6	19.8	21.0	16.7	17.2	18.9	21.0	18.2	21.3	18.4	18.7	19.2	20.8	18.9	19.3	20.4	19.7	19.9		
16.0		13.3	15.1	12.3	13.1	14.1	15.6	15.8	13.3	15.3	16.6	12.4	12.9	14.5	16.5	13.8	16.8	13.9	14.3	14.8	16.3	13.5	14.5	14.8	15.9	15.3	15.4	
18.0			10.4	12.2	9.1	10.0	11.0	12.4	12.6	10.1	12.1	13.3	9.2	9.7	11.3	13.2	10.6	13.5	10.7	11.1	11.5	13.0	11.3	11.6	12.7	12.0	12.2	
20.0					6.5	7.6	8.7	10.1	10.3	7.6	9.7	10.9	6.5	7.1	8.9	10.8	8.2	11.0	8.3	8.7	9.1	10.6						

カウンタウエイト 16.5t、アウトリガ張出幅 5.5m

ブーム

単位:t

性能ブロック	1	3	1	3	5	4	2	1	4	2	1	4	6	2	1	2	1	7	9	8	1	10	11	1	1	12																	
性能番号	1	14	2	15	19	16	10	3	17	11	4	18	20	12	5	13	6	21	23	22	7	24	25	8	9	26																	
ブーム長さ(m)	15.0		20.1		25.1				30.2				35.3				40.4				45.4				50.5				55.6		60.0												
作業半径(m)	3.0	194.9	170.0	134.8	162.0	139.0	139.0	102.4																																			
3.5	174.9	170.0	127.0	162.0	139.0	139.0	130.9	95.4																																			
4.0	157.8	157.3	119.9	156.5	139.0	139.0	122.5	89.2	139.0	126.8	85.4																																
4.5	135.5	134.4	113.7	132.6	134.4	136.6	115.0	83.8	135.0	120.1	80.1																																
5.0	103.2	102.3	105.7	100.7	102.3	104.1	106.8	79.0	102.8	106.6	75.4	101.2	102.1	105.1	68.0																												
6.0	68.4	67.7	70.4	66.4	67.6	69.2	71.4	70.9	68.1	71.2	67.4	66.8	67.5	70.0	60.7	69.2	63.3																										
7.0	49.9	49.3	51.8	48.2	49.3	50.7	52.6	52.9	49.7	52.5	54.1	48.5	49.2	51.4	54.1	50.6	54.6	50.8	51.3	51.9	54.0																						
8.0	38.6	38.0	40.3	37.0	38.0	39.2	41.0	41.3	38.3	40.9	42.4	37.3	37.8	39.8	42.3	39.2	42.8	39.3	39.8	40.3	42.3	40.0	40.4	41.8																			
9.0	30.8	30.3	32.4	29.3	30.3	31.5	33.1	33.4	30.6	33.0	34.4	29.6	30.1	32.0	34.4	31.4	34.8	31.5	31.9	32.5	34.3	32.2	32.5	33.9	33.1																		
10.0	25.3	24.8	26.8	23.8	24.7	25.8	27.4	27.7	25.0	27.3	28.6	24.0	24.6	26.3	28.6	25.7	29.0	25.9	26.3	26.8	28.5	26.5	26.8	28.1	27.4	27.6																	
11.0	21.1	20.6	22.5	19.6	20.5	21.6	23.1	23.4	20.8	23.0	24.2	19.8	20.3	22.1	24.2	21.4	24.6	21.6	22.0	22.4	24.1	22.2	22.5	23.7	23.0	23.2																	
12.0	17.8	17.3	19.2	16.4	17.2	18.3	19.8	20.0	17.4	19.6	20.8	16.6	17.0	18.7	20.8	18.1	21.1	18.2	18.6	19.1	20.7	18.8	19.1	20.3	19.6	19.8																	
14.0		12.5	14.3	11.6	12.4	13.4	14.8	15.0	12.6	14.6	15.8	11.7	12.2	13.8	15.8	13.2	16.1	13.3	13.7	14.1	15.6	13.8	14.2	15.3	14.6	14.8																	
16.0		9.2	11.0	8.1	9.1	10.0	11.4	11.6	9.2	11.2	12.4	8.2	8.8	10.4	12.3	9.8	12.6	9.9	10.2	10.6	12.1	10.4	10.7	11.8	11.1	11.3																	
18.0		6.7	8.7	5.4	6.3	7.5	9.0	9.2	6.5	8.7	9.8		6.0	7.8	9.7	7.0	10.0	7.2	7.6	8.1	9.5	7.8	8.1	9.2	8.6	8.7																	
20.0					4.3	5.4	7.1	7.3	4.4	6.7	7.9			5.7	7.8	4.9	8.0	5.0	5.4	5.9	7.6	5.6	5.9	7.2	6.4	6.6																	
22.0						3.8	5.5	5.8			5.0	6.4				6.2				4.1	5.9				5.4																		
24.0											3.7	5.1				4.8					4.5				4.0																		
26.0												4.0				3.7					3.3																						
28.0																	2.8																										
ピン無最大荷重	60.0	63.0	69.0	59.0				63.0	66.0	44.0	59.0	63.0	66.0	49.0				59.0	44.0	48.0	61.0	49.0				53.0	40.0	40.4	41.8	33.1	27.6												
θ(°)	0~79	0~84.5		33~84.5		22~84.5		0~84.5				41~84.5		26~84.5		12~84.5		59~84.5		55~84.5		50~84.5		35~84.5		57~84.5		41~84.5		61~84.5		58~84.5		52~84.5		65~84.5		60~84.5		68~84.5		71~84.5	
伸縮ブーム1	0	0	0	0	45	45	0	0	0	45	0	0	90	90	45	0	90	0	90	90	90	0	90	90	45	90	100																
伸縮ブーム2	0	45	0	0	45	0	45	0	0	45	45	0	45	45	0	45	45	90	45	90	45	90	90	45	90	100																	
伸縮ブーム3	0	0	0	0	45	45	45	0	45	45	45	45	0	45	90	45	90	45	0	45	90	90	45	90	100																		
伸縮ブーム4	0	0	45	0	0	0	45	90	0	45	90	0	45	90	0	45	90	45	90	45	90	45	90	90	100																		
標準フック	200t	200t		200t				200t				200t				80t		80t		80t				80t		80t		80t															
フック重量	3200kg	3200kg		3200kg				3200kg				3200kg				1550kg		1550kg		1550kg				1550kg		1550kg																	
補巻時標準巻掛本数	20	17	13	16	13			10	13	12	8	9	10		6	6	5				4		3	3																			
主巻時標準巻掛本数	18	13		11				10	9	8	8				6	6	5				4		3	3																			
主巻時最大荷重	186.1	141.0	134.8	121.6				102.4	101.5	85.4	91.1				68.0	69.2	63.3	50.8	51.3	51.9	54.0	40.0	40.4	41.8	33.1	27.6																	

カウンタウエイト 7.5t、アウトリガ張出幅 8.5m

ブーム

単位:t

性能ブロック	1	3	1	3	5	4	2	1	4	2	1	4	6	2	1	2	1	7	9	8	1	10	11	1	1	12						
性能番号	1	14	2	15	19	16	10	3	17	11	4	18	20	12	5	13	6	21	23	22	7	24	25	8	9	26						
ブーム長さ(m)	15.0		20.1		25.1				30.2				35.3				40.4				45.4				50.5				55.6		60.0	
作業半径(m)	3.0	200.0	170.0	134.8	162.0	139.0	139.0	102.4																								
3.5	200.0	170.0	127.0	162.0	139.0	139.0	130.9	95.4																								
4.0	182.6	170.0	119.9	162.0	139.0	139.0	122.5	89.2	139.0	126.8	85.4																					
4.5	165.5	165.1	113.7	162.0	139.0	139.0	115.0	83.8	139.0	120.1	80.1																					
5.0	150.8	150.4	108.1	149.7	139.0	139.0	108.5	79.0	139.0	114.0	75.4	123.3	123.4	113.1	68.0																	
6.0	127.1	126.7	98.5	125.8	126.7	127.6	97.4	70.9	127.0	103.6	67.4	110.9	111.1	107.6	60.7	84.2	63.3															
7.0	89.0	88.3	90.5	86.9	88.3	90.0	88.3	64.4	88.7	92.3	60.9	87.3	88.1	90.9	54.7	84.2	57.6	71.6	71.4	68.0	57.4											
8.0	65.7	65.0	68.1	63.6	65.0	66.7	69.2	58.9	65.5	69.0	55.6	64.0	64.8	67.6	49.8	66.6	52.9	66.9	67.5	65.1	54.4	54.3	54.1	48.8								
9.0	49.8	49.2	52.0	47.9	49.2	50.7	52.9	53.3	49.6	52.7	51.1	48.3	49.0	51.4	45.7	50.6	48.8	50.8	51.3	52.0	50.6	51.6	52.1	48.8	45.0							
10.0	39.5	38.9	41.4	37.7	38.9	40.3	42.3	42.6	39.2	42.1	43.8	38.0	38.7	40.9	42.2	40.1	44.2	40.3	40.8	41.4	43.6	41.1	41.5	43.1	42.2	34.5						
11.0	32.3	31.7	34.0	30.6	31.6	32.9	34.8	35.1	31.9	34.6	36.2	30.8	31.4	33.5	36.2	32.8	36.6	32.9	33.4	34.0	36.0	33.6	34.1	35.5	34.7	34.5						
12.0	26.9	26.3	28.6	25.2	26.3	27.5	29.3	29.6	26.5	29.1	30.6	25.5	26.1	28.0	30.5	27.3	30.9	27.4	27.9	28.4	30.4	28.1	28.5	29.9	29.1	29.3						
14.0		19.0	21.0	17.9	18.8	20.0	21.7	21.9	19.1	21.4	22.8	18.1	18.6	20.4	22.7	19.7	23.1	19.9	20.3	20.8	22.6	20.5	20.9	22.1	21.4	21.6						
16.0		13.9	16.1	12.8	13.7	14.9	16.6	16.9	13.9	16.4	17.7	12.9	13.4	15.3	17.6	14.6	17.9	14.7	15.1	15.7	17.4	15.3	15.7	17.0	16.3	16.4						
18.0		10.5	12.6	9.2	10.1	11.2	12.9	13.1	10.3	12.5	13.9	9.3	9.8	11.5	13.8	10.8	14.1	10.9	11.3	11.8	13.6	11.5	11.9	13.1	12.4	12.6						
20.0				6.4	7.5	8.6	10.2	10.4	7.6	9.8	11.1	6.3	7.0	8.8	11.0	8.1	11.2	8.2	8.6	9.1	10.7	8.7	9.1	10.3	9.6	9.7						
22.0				4.2	5.3	6.6	8.2	8.4	5.3	7.7	9.0			6.7	8.8	5.8	9.0	5.9	6.4	6.9	8.5	6.5	7.0	8.1	7.4	7.6						
24.0									3.5	6.1	7.3			4.9	7.2	3.9	7.3		4.5	5.1	6.8	4.6	5.1	6.4	5.6	5.7						
26.0										4.7	6.1				5.8		5.9			3.5	5.4											
28.0										3.7	5.2				4.7		4.7				4.1				3.6							
30.0															3.7		3.7				3.1											
32.0																	2.8															
ピン無最大荷重	60.0	63.0	69.0	59.0				63.0	66.0	44.0	59.0	63.0	66.0	49.0				59.0	44.0	48.0	61.0	49.0				53.0	48.0	48.8	45.0	34.5		
θ(°)	0~79	0~84.5																														

カウンタウエイト 7.5t、アウトリガ張出幅 5.5m

ブーム

単位:t

性能ブロック	1	3	1	3	5	4	2	1	4	2	1	4	6	2	1	2	1	7	9	8	1	10	11	1	1	12				
性能番号	1	14	2	15	19	16	10	3	17	11	4	18	20	12	5	13	6	21	23	22	7	24	25	8	9	26				
ブーム長さ(m)	15.0	20.1		25.1				30.2				35.3				40.4				45.4				50.5				55.6		60.0
作業半径(m)	3.0	190.0	170.0	134.8	162.0	139.0	139.0	102.4																						
3.5	170.2	169.7	127.0	162.0	139.0	139.0	130.9	95.4																						
4.0	151.4	150.9	119.9	150.1	139.0	139.0	122.5	89.2	139.0	126.8	85.4																			
4.5	107.4	106.4	110.4	104.6	106.4	108.6	111.8	83.8	107.0	111.5	80.1																			
5.0	81.3	80.5	83.9	79.0	80.5	82.4	85.1	79.0	81.0	84.9	75.4	79.4	80.3	83.3	68.0															
6.0	53.2	52.6	55.3	51.3	52.6	54.1	56.3	56.6	53.0	56.1	58.0	51.7	52.4	54.9	58.0	54.1	58.6													
7.0	38.4	37.8	40.2	36.7	37.8	39.1	41.1	41.4	38.2	40.9	42.6	37.0	37.6	39.8	42.5	39.1	43.1	39.3	39.8	40.4	42.5									
8.0	29.2	28.7	30.9	27.6	28.7	29.9	31.7	32.0	29.0	31.5	33.0	27.9	28.5	30.5	33.0	29.8	33.5	30.0	30.4	31.0	32.9	30.7	31.1	32.5						
9.0	23.0	22.5	24.6	21.5	22.4	23.6	25.3	25.6	22.7	25.1	26.5	21.8	22.3	24.2	26.5	23.5	26.9	23.7	24.1	24.6	26.4	24.3	24.7	26.0	25.2					
10.0	18.5	18.0	20.0	17.1	18.0	19.1	20.7	20.9	18.2	20.5	21.9	17.3	17.8	19.6	21.8	19.0	22.2	19.1	19.5	20.0	21.7	19.7	20.1	21.3	20.6	20.8				
11.0	15.1	14.6	16.5	13.7	14.6	15.6	17.2	17.4	14.8	17.0	18.3	13.9	14.4	16.1	18.3	15.5	18.6	13.6	16.0	16.5	18.2	16.2	16.6	17.8	17.1	17.3				
12.0	12.5	12.0	13.8	11.1	11.9	13.0	14.5	14.7	12.1	14.3	15.5	11.3	11.7	13.4	15.5	12.8	15.8	12.9	13.3	13.8	15.4	13.5	13.8	15.0	14.3	14.5				
14.0		8.1	9.9	7.0	8.0	9.0	10.5	10.7	8.2	10.3	11.5			9.4	11.4	8.8	11.7	8.9	9.3	9.7	11.3	9.5	9.8	10.9	10.2	10.4				
16.0			5.1	7.3	5.0	6.2	7.7	7.9	5.3	7.5	8.7				8.6	5.8	8.9			6.9	8.4	8.0			8.0					
18.0				5.2		3.9	5.6	5.9		5.3	6.6				6.5		6.7			6.3		6.3			5.9					
20.0							3.9	4.2			4.9				4.8		5.0			4.5										
22.0											3.6						3.6													
ピン無最大荷重	60.0	63.0	69.0		59.0	63.0	66.0	44.0	59.0	63.0	66.0	49.0	59.0	44.0	48.0	58.6	39.3	39.8	40.4	42.5	30.7	31.1	32.5	25.2	20.8					
θ(°)	0~79	13~84.5	0~84.5	48~84.5	41~84.5	33~84.5	22~84.5	44~84.5	57~84.5	46~84.5	34~84.5	66~84.5	62~84.5	50~84.5	64~84.5	53~84.5	70~84.5	67~84.5	61~84.5	73~84.5	67~84.5	75~84.5	77~84.5							
伸長状態(伸長割合%)																														
伸縮ブーム1	0	0	0	45	45	0	0	0	45	0	0	90	90	45	0	90	0	90	90	90	0	90	90	45	90	100				
伸縮ブーム2	0	45	0	45	0	45	0	45	45	45	0	45	45	45	0	45	45	90	90	45	90	90	90	90	90	100				
伸縮ブーム3	0	0	0	0	45	45	0	45	45	45	0	45	45	45	0	45	45	90	90	45	90	90	90	90	90	100				
伸縮ブーム4	0	0	45	0	0	0	45	90	0	45	90	0	45	90	0	45	90	90	90	45	90	90	90	90	90	100				
標準フック	200t	200t	200t	200t	200t	200t	200t	200t	200t	200t	200t	80t	200t	80t	200t	80t	200t	80t	200t	80t	200t	80t	200t	80t	200t	80t	200t			
フック重量	3200kg	3200kg	3200kg	3200kg	3200kg	3200kg	3200kg	3200kg	3200kg	3200kg	3200kg	1550kg	3200kg	1550kg	1550kg	1550kg	1550kg	1550kg	1550kg	1550kg	1550kg	1550kg	1550kg	1550kg	1550kg	1550kg	1550kg			
補巻時標準巻掛本数	19	17	13	16	13	10	13	12	8	7	8	6	5	4	3	4	3	3	3	3	3	3	3	3	3	3				
主巻時標準巻掛本数	18	13	11	10	9	8	7	8	7	8	6	5	4	3	3	3	3	3	3	3	3	3	3	3	3	3				
主巻時最大荷重	186.1	141.0	134.8	121.6	102.4	101.5	85.4	79.4	80.3	83.3	68.0	54.1	58.6	39.3	39.8	40.4	42.5	30.7	31.1	32.5	25.2	20.8								

カウンタウエイト 0t、アウトリガ張出幅 8.5m

ブーム

単位:t

性能ブロック	1	1	1	1	1	1	1	1	1	12
性能番号	1	2	3	4	5	6	7	8	9	26
ブーム長さ(m)	15.0	20.1	25.1	30.2	35.3	40.4	45.4	50.5	55.6	60.0
作業半径(m)	3.0	200.0	134.8	102.4						
3.5	195.5	127.0	95.4							
4.0	175.5	119.9	89.2	85.4						
4.5	158.5	113.7	83.8	80.1						
5.0	144.0	108.1	79.0	75.4	68.0					
6.0	99.3	98.5	70.9	67.4	60.7	63.3				
7.0	64.0	67.1	64.4	60.9	54.7	57.4	57.4			
8.0	44.3	46.9	48.5	49.9	49.8	50.4	49.7	48.8		
9.0	32.9	35.2	36.6	37.8	37.9	38.3	37.6	37.0	36.0	
10.0	25.3	27.6	28.8	30.0	30.3	29.8	29.2	28.3	28.5	
11.0	19.3	21.5	22.9	24.1	24.1	24.5	23.9	23.2	22.2	22.5
12.0	15.1	17.1	18.3	19.4	19.4	19.8	19.2	18.6	17.7	17.9
14.0		11.3	12.4	13.3	13.3	13.6	13.1	12.6	11.7	11.9
16.0		7.8	8.7	9.5	9.5	9.7	9.2	8.7		
18.0		5.5	6.1	6.9	6.9	7.1	6.6			
20.0			4.3	5.0	5.2					
ピン無最大荷重	60.0	69.0	44.0	66.0	44.0	61.0	53.0	48.8	36.0	28.5
θ(°)	0~79	0~84.5	22~84.5	41~84.5	55~84.5	57~84.5	64~84.5	70~84.5	75~84.5	77~84.5
伸長状態(伸長割合%)										
伸縮ブーム1	0	0	0	0	0	0	0	45	90	100
伸縮ブーム2	0	0	0	0	0	45	90	90	90	100
伸縮ブーム3	0	0	0	45	90	90	90	90	90	100
伸縮ブーム4	0	45	90	90	90	90	90	90	90	100
標準フック	200t	200t	200t	200t	80t	80t	80t	80t	80t	80t
フック重量	3200kg	3200kg	3200kg	3200kg	1550kg	1550kg	1550kg	1550kg	1550kg	1550kg
補巻時標準巻掛本数	20	13	10	8	6	6	5	5	4	3
主巻時標準巻掛本数	18	13	10	8	6	6	5	5	4	3
主巻時最大荷重	186.1	134.8	102.4	85.4	68.0	63.3	57.4	48.8	36.0	28.5

カウンタウエイト 0t、アウトリガ張出幅 8.0m

ブーム

単位:t

性能ブロック	1	1	1	1	1	1	1	1	1	12
性能番号	1	2	3	4	5	6	7	8	9	26
ブーム長さ(m)	15.0	20.1	25.1	30.2	35.3	40.4	45.4	50.5	55.6	60.0
作業半径(m)	3.0	200.0	134.8	102.4						
3.5	191.0	127.0	95.4							
4.0	171.1	119.9	89.2	85.4						
4.5	154.3	113.7	83.8	80.1						
5.0	140.0	108.1	79.0	75.4	68.0					
6.0	86.4	90.2	70.9	67.4	60.7	63.3				
7.0	54.2	57.2	58.9	60.5	54.7	57.6	57.4			
8.0	38.2	40.7	42.2	43.5	43.5	44.0	43.3	42.7		
9.0	28.6	30.8	32.1	33.3	33.3	33.7	33.1	32.5	31.6	
10.0	22.2	24.2	25.4	26.5	26.5					

ブーム

カウンタウエイト 0t、アウトリガ張出幅 6.8m

ブーム		単位:t									
性能ブロック	1	1	1	1	1	1	1	1	1	1	12
性能番号	1	2	3	4	5	6	7	8	9	26	
ブーム長さ(m)	15.0	20.1	25.1	30.2	35.3	40.4	45.4	50.5	55.6	60.0	
作業半径(m)											
3.0	199.9	134.8	102.4								
3.5	178.2	127.0	95.4								
4.0	158.8	119.9	89.2	85.4							
4.5	142.0	113.7	83.8	80.1							
5.0	94.5	98.5	79.0	75.4	68.0						
6.0	54.3	57.2	59.0	60.6	60.7	61.2					
7.0	36.4	38.8	40.3	41.7	41.7	42.1	41.5				
8.0	26.3	28.5	29.8	31.0	31.0	31.4	30.8	30.2			
9.0	19.9	21.8	23.0	24.1	24.1	24.5	23.9	23.4	22.6		
10.0	15.4	17.2	18.3	19.3	19.3	19.6	19.1	18.6	17.8	18.1	
11.0	12.1	13.8	14.9	15.8	16.1	15.6	15.1	14.4	14.4	14.6	
12.0	9.6	11.2	12.2	13.1	13.1	13.4	12.9	12.4	11.7	11.7	
14.0		7.6	8.4	9.2	9.2	9.5	9.0	8.6			
16.0		5.0	5.9	6.6	6.6	6.8	6.4				
18.0			3.9			4.8					
ピン無最大荷重	60.0	69.0	44.0	66.0	44.0	61.0	41.5	30.2	22.6	18.1	
θ(°)	0~	13~	33~	52~	59~	60~	67~	72~	77~	80~	
	79	84.5	84.5	84.5	84.5	84.5	84.5	84.5	84.5	84.5	
伸長状態(伸長割合%)											
伸縮ブーム1	0	0	0	0	0	0	0	45	90	100	
伸縮ブーム2	0	0	0	0	0	45	90	90	90	100	
伸縮ブーム3	0	0	0	45	90	90	90	90	90	100	
伸縮ブーム4	0	45	90	90	90	90	90	90	90	100	
標準フック	200t	200t	200t	200t	80t	80t	80t	80t	80t	80t	
フック重量	3200kg	3200kg	3200kg	3200kg	1550kg	1550kg	1550kg	1550kg	1550kg	1550kg	
補巻時標準巻掛本数	20	13	10	8	6	6	4	3	2	2	
主巻時標準巻掛本数	18	13	10	8	6	6	4	3	2	2	
主巻時最大荷重	186.1	134.8	102.4	85.4	68.0	61.2	41.5	30.2	22.6	18.1	

カウンタウエイト 0t、アウトリガ張出幅 5.5m

ブーム		単位:t							
性能ブロック	1	1	1	1	1	1	1	1	1
性能番号	1	2	3	4	5	6	7	8	
ブーム長さ(m)	15.0	20.1	25.1	30.2	35.3	40.4	45.4	50.5	
作業半径(m)									
3.0	183.1	134.8	102.4						
3.5	160.7	127.0	95.4						
4.0	101.5	105.8	89.2	85.4					
4.5	69.7	73.0	75.1	76.9					
5.0	51.9	54.8	56.6	58.2	58.2				
6.0	32.9	35.2	36.6	37.9	38.0	38.4			
7.0	22.8	24.8	26.1	27.2	27.3	27.6	27.1		
8.0	16.6	18.4	19.6	20.6	20.6	21.0	20.5	19.9	
9.0	12.3	14.1	15.1	16.1	16.1	16.4	16.0	15.5	
10.0	9.3	10.9	11.9	12.8	12.9	13.1	12.7	12.2	
11.0	7.0	8.6	9.5	10.4	10.4	10.7	10.2		
12.0	5.0	6.7	7.6	8.5	8.5	8.7	8.3		
14.0						5.9			
ピン無最大荷重	60.0	69.0	44.0	66.0	44.0	38.4	27.1	19.9	
θ(°)	0~	41~	54~	61~	66~	67~	73~	77~	
	79	84.5	84.5	84.5	84.5	84.5	84.5	84.5	
伸長状態(伸長割合%)									
伸縮ブーム1	0	0	0	0	0	0	0	45	
伸縮ブーム2	0	0	0	0	0	45	90	90	
伸縮ブーム3	0	0	0	45	90	90	90	90	
伸縮ブーム4	0	45	90	90	90	90	90	90	
標準フック	200t	200t	200t	200t	80t	80t	80t	80t	
フック重量	3200kg	3200kg	3200kg	3200kg	1550kg	1550kg	1550kg	1550kg	
補巻時標準巻掛本数	18	13	10	8	5	4	3	2	
主巻時標準巻掛本数	18	13	10	8	5	4	3	2	
主巻時最大荷重	183.1	134.8	102.4	85.4	58.2	38.4	27.1	19.9	

カウンタウエイト 0t、アウトリガ張出幅 2.7m

ブーム		単位:t			
性能ブロック	1	1	1	1	
性能番号	1	2	3	4	
ブーム長さ(m)	15.0	20.1	25.1	30.2	
作業半径(m)					
3.0	35.0	35.0	35.0		
3.5	26.7	28.9	30.3		
4.0	19.8	21.8	23.0	24.1	
4.5	15.0	16.9	18.1	19.1	
5.0	11.6	13.4	14.5	15.4	
6.0	7.0	8.6	9.6	10.5	
ピン無最大荷重	35.0	35.0	35.0	24.1	
θ(°)	54~	64~	70~	74~	
	79	84.5	84.5	84.5	
伸長状態(伸長割合%)					
伸縮ブーム1	0	0	0	0	
伸縮ブーム2	0	0	0	0	
伸縮ブーム3	0	0	0	45	
伸縮ブーム4	0	45	90	90	
標準フック	80t	80t	80t	80t	
フック重量	1550kg	1550kg	1550kg	1550kg	
補巻時標準巻掛本数	3	3	3	2	
主巻時標準巻掛本数	3	3	3	2	
主巻時最大荷重	35.0	35.0	35.0	24.1	

カウンタウエイト 0t、アウトリガ張出幅 2.7m、後方±5° 範囲のみ

ブーム		単位:t			
性能ブロック	1	1	1	1	
性能番号	1	2	3	4	
ブーム長さ(m)	15.0	20.1	25.1	30.2	
作業半径(m)					
3.0	35.0	35.0	35.0		
3.5	35.0	35.0	35.0		
4.0	35.0	35.0	35.0	35.0	
4.5	35.0	35.0	35.0	35.0	
5.0	35.0	35.0	35.0	35.0	
6.0	35.0	35.0	35.0	35.0	
7.0	35.0	35.0	35.0	35.0	
8.0	35.0	35.0	35.0	35.0	
9.0	33.4	35.0	35.0	35.0	
10.0	24.5	26.9	28.4	29.8	
11.0	18.6	20.9	22.2	23.4	
12.0	14.6	16.6	17.8	18.9	
14.0		11.0	12.0	13.0	
16.0		7.5	8.4	9.2	
18.0		5.2	5.9	6.7	
20.0			4.1	4.9	
22.0			2.6	3.4	
24.0				2.2	
ピン無最大荷重	35.0	35.0	35.0	35.0	
θ(°)	0~	0~	0~	0~	
	79	84.5	84.5	84.5	
伸長状態(伸長割合%)					
伸縮ブーム1	0	0	0	0	
伸縮ブーム2	0	0	0	0	
伸縮ブーム3	0	0	0	45	
伸縮ブーム4	0	45	90	90	
標準フック	80t	80t	80t	80t	
フック重量	1550kg	1550kg	1550kg	1550kg	
補巻時標準巻掛本数	3	3	3	3	
主巻時標準巻掛本数	3	3	3	3	
主巻時最大荷重	35.0	35.0	35.0	35.0	

PS+ブーム作業半径-揚程図

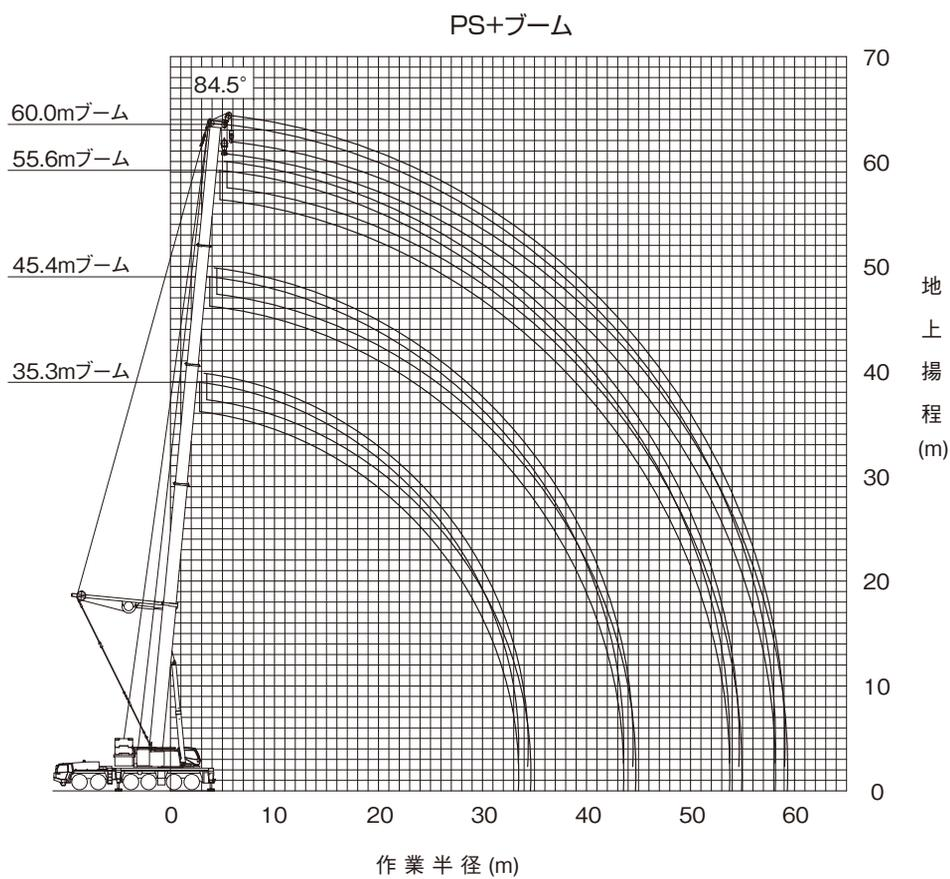

(注意)

- ◆ 上図はブームのたわみを含んでいません。
- ◆ カウンタウエイト98t、アウトリガ張出幅8.5mの性能を図示しています。

PS+ブーム定格総荷重表

■ 定格総荷重表注意事項

◆性能設定のあるカウンタウエイトとアウトリガ張出幅の組合せを、下表に○印で示します。

アウトリガ張出幅	カウンタウエイト	138 t	118 t	98 t	78 t	58 t	47 t	25 t	0 t
8.5 m		○	○	○	○	○	○	○	○
8.0 m			○	○	○	○	○	○	○
6.8 m					○	○	○	○	○

◆定格総荷重は、つり具質量とフック質量(200トンフック:3,200kg、80トンフック: 1,550kg、12.2トンフック:440kg)を含んだ値を示します。

◆定格総荷重は、ブームのたわみを含んだ実際の作業半径に基づいています。

◆各ブーム長さにおける各伸縮ブームの伸長状態(伸長割合%)は、下表のとおりです。

カウンタウエイト	0 t				138 ~ 25 t					
ブーム長さ	15.0 m	20.1 m	25.1 m	35.3 m	40.4 m	45.4 m	50.5 m	55.6 m	60.0 m	
伸縮ブーム1	0	0	0	90	90	90	90	90	100	
伸縮ブーム2	0	0	0	90	90	90	90	90	100	
伸縮ブーム3	0	0	0	0	45	90	90	90	100	
伸縮ブーム4	0	45	90	0	0	0	45	90	100	

◆カウンタウエイト138~25tの性能ではブーム長さ35.3m未満の性能設定はありません。また、カウンタウエイト0tの性能ではブーム長さ25.1mを超える性能設定はありません。さらに、全ての性能においてBピン(ブーム固定ピン)を挿入していない状態では使用できません。

◆定格総荷重表中の標準巻掛本数より少ない本数で使用する場合、最大荷重の上限は下表のとおりです。

巻掛本数	9本	8本	7本	6本	5本	4本	3本	1本
最大荷重	101.5t	91.1t	80.5t	69.7t	58.6t	47.4t	35.9t	12.2t

◆シングルトップ使用時の巻掛本数は1本(12.2トンフック使用)で、定格総荷重はブームの定格総荷重からブームに取り付けられているフックの質量を差し引いた値とし、かつ上限は12.2tです。

◆定格総荷重は、アウトリガを水平堅土上に設置したときの値です。

◆定格総荷重表は、風による影響を含んでいません。瞬間最大風速が10m/s以上の風速では、クレーン作業を中止してください。

定格総荷重表中の線、および用語説明

◆太線より上側はクレーンの強度に、下側はクレーンの安定に基づいています。

◆「 θ° 」は、無負荷状態で作動可能なブーム起伏角度範囲を示します。

◆「補巻時・標準巻掛本数」は、補巻使用時の標準巻掛本数を示します。

◆「主巻時・標準巻掛本数」は、主巻使用時の標準巻掛本数を示し、補巻よりもワイヤロープ長さが短いため、巻掛本数が少なくなる場合があります。

◆「主巻時・最大荷重」は、主巻使用時の定格総荷重の上限を示します。

PS+ブーム

カウンタウエイト 138t、アウトリガ張出幅 8.5m

PS+ブーム		単位:t					
ブーム長さ(m)	35.3	40.4	45.4	50.5	55.6	60.0	
作業半径(m)							
8.0	101.4						
9.0	93.8	84.2	68.0	58.0	45.0		
10.0	86.3	82.4	68.0	58.0	45.0	34.9	
11.0	79.6	76.8	68.0	58.0	45.0	34.8	
12.0	74.6	71.2	68.0	58.0	44.8	34.6	
14.0	65.3	62.8	59.9	58.0	44.4	34.2	
16.0	58.1	55.6	53.7	51.6	44.0	33.8	
18.0	52.4	50.3	48.0	46.8	43.7	33.4	
20.0	47.6	45.6	43.9	42.5	41.3	33.0	
22.0	43.5	41.6	40.0	39.0	37.7	32.7	
24.0	39.6	38.4	36.9	35.8	34.8	32.4	
26.0	35.1	35.5	34.1	33.2	32.3	31.3	
28.0	30.5	33.0	31.6	30.8	30.0	29.1	
30.0	25.6	29.9	29.5	28.9	28.1	27.1	
32.0	19.2	26.4	27.6	27.1	26.3	25.5	
34.0		22.8	25.7	25.4	24.8	23.8	
36.0		18.4	23.0	24.0	23.4	22.6	
38.0		11.4	20.1	22.6	22.1	21.3	
40.0			16.9	20.6	21.0	20.3	
42.0			12.6	18.4	19.9	19.2	
44.0				15.9	18.5	18.3	
46.0				12.9	16.7	17.4	
48.0				8.3	14.7	16.1	
50.0					12.5	14.5	
52.0					9.5	12.8	
54.0						10.9	
56.0						8.4	
58.0						3.7	
θ (°)	4~ 77	5~ 78	4~ 79	5~ 81	6~ 82	6~ 82	
標準フック	200t		80t				
フック重量	3200kg		1550kg				
補巻時 標準巻掛本数	9	8	6	5	4	3	
主巻時 標準巻掛本数	8	6	6	5	4	3	
主巻時 最大荷重	91.1	69.7	68.0	58.0	45.0	34.9	

カウンタウエイト 118t、アウトリガ張出幅 8.5m

PS+ブーム		単位:t					
ブーム長さ(m)	35.3	40.4	45.4	50.5	55.6	60.0	
作業半径(m)							
4.5	118.0						
5.0	118.0						
6.0	118.0	84.2					
7.0	112.6	84.2	68.0				
8.0	101.4	84.2	68.0	58.0			
9.0	93.8	84.2	68.0	58.0	45.0		
10.0	86.3	82.4	68.0	58.0	45.0	34.9	
11.0	79.6	76.8	68.0	58.0	45.0	34.8	
12.0	74.6	71.2	68.0	58.0	44.8	34.6	
14.0	65.3	62.8	59.9	58.0	44.4	34.2	
16.0	58.1	55.6	53.7	51.6	44.0	33.8	
18.0	52.4	50.3	48.0	46.8	43.7	33.4	
20.0	47.6	45.6	43.9	42.5	41.3	33.0	
22.0	43.5	41.6	40.0	39.0	37.7	32.7	
24.0	38.5	38.4	36.9	35.8	34.8	32.4	
26.0	33.9	35.1	34.1	33.2	32.3	31.3	
28.0	30.1	31.3	31.6	30.8	30.0	29.1	
30.0	25.6	28.0	28.7	28.9	28.1	27.1	
32.0	19.2	25.2	25.9	26.8	26.3	25.5	
34.0		22.7	23.5	24.3	24.8	23.8	
36.0		18.4	21.3	22.2	22.9	22.6	
38.0		11.4	19.4	20.3	21.0	21.1	
40.0			16.9	18.6	19.3	19.4	
42.0			12.6	17.1	17.8	17.9	
44.0				15.7	16.4	16.5	
46.0				12.9	15.2	15.3	
48.0				8.3	14.1	14.1	
50.0					12.5	13.1	
52.0					9.5	12.2	
54.0						10.9	
56.0						8.4	
58.0						3.7	
θ (°)	4~ 83	5~ 83	4~ 84	5~ 84.5	6~ 84.5	6~ 84.5	
標準フック	200t		80t				
フック重量	3200kg		1550kg				
補巻時 標準巻掛本数	11	8	6	5	4	3	
主巻時 標準巻掛本数	8	6	6	5	4	3	
主巻時 最大荷重	91.1	69.7	68.0	58.0	45.0	34.9	

カウンタウエイト 118t、アウトリガ張出幅 8.0m

PS+ブーム		単位:t					
ブーム長さ(m)	35.3	40.4	45.4	50.5	55.6	60.0	
作業半径(m)							
5.0	118.0						
6.0	118.0	84.2					
7.0	112.6	84.2	68.0				
8.0	101.4	84.2	68.0	58.0			
9.0	93.8	84.2	68.0	58.0	45.0		
10.0	86.3	82.4	68.0	58.0	45.0	34.9	
11.0	79.6	76.8	68.0	58.0	45.0	34.8	
12.0	74.6	71.2	68.0	58.0	44.8	34.6	
14.0	65.3	62.8	59.9	58.0	44.4	34.2	
16.0	58.1	55.6	53.7	51.6	44.0	33.8	
18.0	52.4	50.3	48.0	46.8	43.7	33.4	
20.0	47.6	45.6	43.9	42.5	41.3	33.0	
22.0	42.5	41.6	40.0	39.0	37.7	32.7	
24.0	37.8	38.4	36.9	35.8	34.8	32.4	
26.0	33.3	34.5	34.1	33.2	32.3	31.3	
28.0	29.5	30.6	31.4	30.8	30.0	29.1	
30.0	25.6	27.3	28.1	28.9	28.1	27.1	
32.0	19.2	24.5	25.3	26.2	26.3	25.5	
34.0		22.1	22.9	23.8	24.5	23.8	
36.0		18.4	20.7	21.6	22.4	22.4	
38.0		11.4	18.9	19.7	20.5	20.5	
40.0			16.9	18.1	18.8	18.8	
42.0			12.6	16.6	17.3	17.3	
44.0				15.2	15.9	16.0	
46.0				12.9	14.7	14.8	
48.0				8.3	13.6	13.6	
50.0					12.5	12.6	
52.0					9.5	11.7	
54.0						10.9	
56.0						8.4	
58.0						3.7	
θ (°)	4~ 82	5~ 82	4~ 83	5~ 84	6~ 84.5	6~ 84.5	
標準フック	200t	200t	80t	80t	80t	80t	
フック重量	3200kg	3200kg	1550kg	1550kg	1550kg	1550kg	
補巻時 標準巻掛本数	11	8	6	5	4	3	
主巻時 標準巻掛本数	8	6	6	5	4	3	
主巻時 最大荷重	91.1	69.7	68.0	58.0	45.0	34.9	

カウンタウエイト 98t、アウトリガ張出幅 8.5m

PS+ブーム		単位:t					
ブーム長さ(m)	35.3	40.4	45.4	50.5	55.6	60.0	
作業半径(m)							
4.0	118.0						
4.5	118.0						
5.0	118.0						
6.0	118.0	84.2					
7.0	112.6	84.2	68.0				
8.0	101.4	84.2	68.0	58.0			
9.0	93.8	84.2	68.0	58.0	45.0		
10.0	86.3	82.4	68.0	58.0	45.0	34.9	
11.0	79.6	76.8	68.0	58.0	45.0	34.8	
12.0	74.6	71.2	68.0	58.0	44.8	34.6	
14.0	65.3	62.8	59.9	58.0	44.4	34.2	
16.0	58.1	55.6	53.7	51.6	44.0	33.8	
18.0	51.2	50.3	48.0	46.8	43.7	33.4	
20.0	43.4	44.7	43.9	42.5	41.3	33.0	
22.0	37.2	38.5	39.3	39.0	37.7	32.7	
24.0	32.3	33.5	33.3	35.3	34.8	32.4	
26.0	28.2	29.4	30.2	31.1	31.9	31.3	
28.0	24.9	26.0	26.8	27.7	28.5	28.6	
30.0	22.0	23.1	23.9	24.8	25.6	25.6	
32.0	19.2	20.7	21.4	22.3	23.1	23.1	
34.0		18.5	19.3	20.1	20.9	20.9	
36.0		16.7	17.4	18.2	19.0	19.0	
38.0		11.4	15.7	16.6	17.3	17.4	
40.0			14.2	15.1	15.8	15.9	
42.0			12.6	13.8	14.5	14.5	
44.0				12.6	13.3	13.3	
46.0				11.5	12.2	12.2	
48.0				8.3	11.2	11.3	
50.0					10.2	10.3	
52.0					9.3	9.4	
54.0						8.5	
56.0						7.7	
58.0						3.7	
θ (°)	4~ 84.5	5~ 84.5	4~ 84.5	5~ 84.5	6~ 84.5	6~ 84.5	
標準フック	200t	200t	80t	80t	80t	80t	
フック重量	3200kg	3200kg	1550kg	1550kg	1550kg	1550kg	
補巻時 標準巻掛本数	11	8	6	5	4	3	
主巻時 標準巻掛本数	8	6	6	5	4	3	
主巻時 最大荷重	91.1	69.7	68.0	58.0	45.0	34.9	

カウンタウエイト 98t、アウトリガ張出幅 8.0m

PS+ブーム

単位:t

ブーム長さ(m) 作業半径(m)	35.3	40.4	45.4	50.5	55.6	60.0
4.0	118.0					
4.5	118.0					
5.0	118.0					
6.0	118.0	84.2				
7.0	112.6	84.2	68.0			
8.0	101.4	84.2	68.0	58.0		
9.0	93.8	84.2	68.0	58.0	45.0	
10.0	86.3	82.4	68.0	58.0	45.0	34.9
11.0	79.6	76.8	68.0	58.0	45.0	34.8
12.0	74.6	71.2	68.0	58.0	44.8	34.6
14.0	65.3	62.8	59.9	58.0	44.4	34.2
16.0	58.1	55.6	53.7	51.6	44.0	33.8
18.0	50.2	50.3	48.0	46.8	43.7	33.4
20.0	42.3	43.6	43.9	42.5	41.3	33.0
22.0	36.2	37.5	38.3	39.0	37.7	32.7
24.0	31.3	32.5	33.3	34.3	34.8	32.4
26.0	27.3	28.5	29.2	30.2	31.0	31.1
28.0	23.9	25.1	25.9	26.8	27.6	27.7
30.0	21.1	22.2	23.0	23.9	24.7	24.8
32.0	18.7	19.8	20.5	21.5	22.2	22.3
34.0		17.7	18.4	19.3	20.1	20.1
36.0		15.9	16.6	17.5	18.2	18.3
38.0		11.4	15.0	15.8	16.6	16.6
40.0			13.5	14.4	15.1	15.1
42.0			12.2	13.1	13.8	13.8
44.0				11.9	12.6	12.7
46.0				10.8	11.5	11.6
48.0				8.3	10.6	10.6
50.0					9.6	9.6
52.0					8.6	8.7
54.0						7.9
56.0						7.1
58.0						3.7
θ (°)	4~84.5	5~84.5	4~84.5	5~84.5	6~84.5	6~84.5
標準フック	200t	200t	80t	80t	80t	80t
フック重量	3200kg	3200kg	1550kg	1550kg	1550kg	1550kg
補巻時標準巻掛本数	11	8	6	5	4	3
主巻時標準巻掛本数	8	6	6	5	4	3
主巻時最大荷重	91.1	69.7	68.0	58.0	45.0	34.9

カウンタウエイト 78t、アウトリガ張出幅 8.0m

PS+ブーム

単位:t

ブーム長さ(m) 作業半径(m)	35.3	40.4	45.4	50.5	55.6	60.0
4.0	118.0					
4.5	118.0					
5.0	118.0					
6.0	118.0	84.2				
7.0	112.6	84.2	68.0			
8.0	101.4	84.2	68.0	58.0		
9.0	93.8	84.2	68.0	58.0	45.0	
10.0	86.3	82.4	68.0	58.0	45.0	34.9
11.0	79.6	76.8	68.0	58.0	45.0	34.8
12.0	74.6	71.2	68.0	58.0	44.8	34.6
14.0	62.5	62.8	59.9	58.0	44.4	34.2
16.0	49.9	51.4	52.3	51.6	44.0	33.8
18.0	40.9	42.3	43.2	44.3	43.7	33.4
20.0	34.2	35.5	36.4	37.4	38.3	33.0
22.0	28.9	30.2	31.0	32.0	32.9	32.7
24.0	24.8	26.0	26.8	27.8	28.6	28.7
26.0	21.3	22.5	23.3	24.3	25.1	25.2
28.0	18.5	19.7	20.4	21.4	22.2	22.2
30.0	16.1	17.2	18.0	18.9	19.7	19.8
32.0	14.1	15.1	15.9	16.8	17.6	17.6
34.0		13.3	14.1	15.0	15.7	15.8
36.0		11.6	12.5	13.4	14.1	14.2
38.0		10.1	11.0	12.0	12.7	12.8
40.0			9.6	10.7	11.5	11.5
42.0			8.4	9.5	10.3	10.4
44.0				8.3	9.2	9.3
46.0				7.3	8.2	8.3
48.0				6.4	7.3	7.3
50.0					6.4	6.5
52.0					5.6	5.7
54.0						5.0
56.0						4.3
58.0						3.7
θ (°)	4~84.5	5~84.5	4~84.5	5~84.5	6~84.5	6~84.5
標準フック	200t	200t	80t	80t	80t	80t
フック重量	3200kg	3200kg	1550kg	1550kg	1550kg	1550kg
補巻時標準巻掛本数	11	8	6	5	4	3
主巻時標準巻掛本数	8	6	6	5	4	3
主巻時最大荷重	91.1	69.7	68.0	58.0	45.0	34.9

カウンタウエイト 78t、アウトリガ張出幅 8.5m

PS+ブーム

単位:t

ブーム長さ(m) 作業半径(m)	35.3	40.4	45.4	50.5	55.6	60.0
4.0	118.0					
4.5	118.0					
5.0	118.0					
6.0	118.0	84.2				
7.0	112.6	84.2	68.0			
8.0	101.4	84.2	68.0	58.0		
9.0	93.8	84.2	68.0	58.0	45.0	
10.0	86.3	82.4	68.0	58.0	45.0	34.9
11.0	79.6	76.8	68.0	58.0	45.0	34.8
12.0	74.6	71.2	68.0	58.0	44.8	34.6
14.0	64.0	62.8	59.9	58.0	44.4	34.2
16.0	51.5	52.9	53.7	51.6	44.0	33.8
18.0	42.5	43.9	44.7	45.7	43.7	33.4
20.0	35.7	37.0	37.8	38.8	39.7	33.0
22.0	30.4	31.6	32.5	33.4	34.3	32.7
24.0	26.1	27.3	28.1	29.1	29.9	30.0
26.0	22.6	23.8	24.6	25.5	26.3	26.4
28.0	19.7	20.9	21.6	22.6	23.4	23.4
30.0	17.3	18.4	19.1	20.1	20.8	20.9
32.0	15.2	16.2	17.0	17.9	18.6	18.7
34.0		14.4	15.1	16.0	16.8	16.8
36.0		12.7	13.5	14.4	15.1	15.2
38.0		11.1	12.0	12.9	13.7	13.7
40.0			10.6	11.6	12.4	12.4
42.0			9.3	10.4	11.2	11.3
44.0				9.2	10.1	10.2
46.0				8.2	9.0	9.1
48.0				7.2	8.1	8.2
50.0					7.2	7.3
52.0					6.4	6.5
54.0						5.7
56.0						5.0
58.0						3.7
θ (°)	4~84.5	5~84.5	4~84.5	5~84.5	6~84.5	6~84.5
標準フック	200t	200t	80t	80t	80t	80t
フック重量	3200kg	3200kg	1550kg	1550kg	1550kg	1550kg
補巻時標準巻掛本数	11	8	6	5	4	3
主巻時標準巻掛本数	8	6	6	5	4	3
主巻時最大荷重	91.1	69.7	68.0	58.0	45.0	34.9

カウンタウエイト 78t、アウトリガ張出幅 6.8m

PS+ブーム

単位:t

ブーム長さ(m) 作業半径(m)	35.3	40.4	45.4	50.5	55.6	60.0
5.0	118.0					
6.0	118.0	84.2				
7.0	112.6	84.2	68.0			
8.0	101.4	84.2	68.0	58.0		
9.0	93.8	84.2	68.0	58.0	45.0	
10.0	86.3	82.4	68.0	58.0	45.0	34.9
11.0	77.9	76.8	68.0	58.0	45.0	34.8
12.0	67.3	68.9	68.0	58.0	44.8	34.6
14.0	52.1	53.6	54.5	55.6	44.4	34.2
16.0	41.8	43.2	44.0	45.1	44.0	33.8
18.0	34.3	35.6	36.4	37.5	38.3	33.4
20.0	28.6	29.8	30.7	31.7	32.5	32.6
22.0	24.1	25.3	26.1	27.1	27.9	28.0
24.0	20.5	21.7	22.5	23.4	24.2	24.3
26.0	17.6	18.7	19.5	20.4	21.2	21.3
28.0	15.1	16.2	17.0	17.9	18.7	18.7
30.0	12.9	14.1	14.9	15.8	16.5	16.6
32.0	10.9	12.2	13.0	13.9	14.7	14.7
34.0		10.4	11.4	12.3	13.1	13.1
36.0		8.9	9.8	10.9	11.6	11.7
38.0		7.5	8.4	9.5	10.4	10.5
40.0			7.2	8.3	9.2	9.3
42.0			6.1	7.2	8.0	8.1
44.0				6.1	7.0	7.1
46.0				5.2	6.1	6.2
48.0				4.4	5.3	5.4
50.0					4.5	4.6
52.0					3.8	3.9
54.0						3.3
56.0						2.7
θ (°)	4~82	5~82	4~83	5~84	6~84.5	9~84.5
標準フック	200t	200t	80t	80t	80t	80t
フック重量	3200kg	3200kg	1550kg	1550kg	1550kg	1550kg
補巻時標準巻掛本数	11	8	6	5	4	3
主巻時標準巻掛本数	8	6	6	5	4	3
主巻時最大荷重	91.1	69.7	68.0	58.0	45.0	34.9

PS+ブーム

カウンタウエイト 58t、アウトリガ張出幅 8.5m

PS+ブーム

単位:t

ブーム長さ(m) 作業半径(m)	35.3	40.4	45.4	50.5	55.6	60.0
4.0	118.0					
4.5	118.0					
5.0	118.0					
6.0	118.0	84.2				
7.0	112.6	84.2	68.0			
8.0	101.4	84.2	68.0	58.0		
9.0	93.8	84.2	68.0	58.0	45.0	
10.0	86.3	82.4	68.0	58.0	45.0	34.9
11.0	78.4	76.8	68.0	58.0	45.0	34.8
12.0	67.4	69.0	68.0	58.0	44.8	34.6
14.0	51.8	53.3	54.2	55.4	44.4	34.2
16.0	41.3	42.7	43.6	44.7	44.0	33.8
18.0	33.7	35.0	35.9	36.9	37.8	33.4
20.0	28.0	29.3	30.1	31.1	32.0	32.0
22.0	23.4	24.7	25.6	26.6	27.4	27.4
24.0	19.7	21.0	21.8	22.8	23.6	23.7
26.0	16.8	18.0	18.8	19.7	20.5	20.6
28.0	14.3	15.4	16.2	17.2	18.0	18.0
30.0	12.1	13.3	14.1	15.0	15.8	15.9
32.0	10.0	11.4	12.3	13.2	13.9	14.0
34.0		9.6	10.6	11.6	12.3	12.4
36.0		8.1	9.0	10.2	10.9	11.0
38.0		6.7	7.6	8.8	9.7	9.8
40.0			6.4	7.5	8.5	8.6
42.0			5.3	6.4	7.4	7.4
44.0				5.4	6.4	6.4
46.0				4.6	5.5	5.5
48.0				3.8	4.6	4.7
50.0					3.9	4.0
52.0					3.2	3.3
54.0						2.7
θ(°)	4~ 84.5	5~ 84.5	4~ 84.5	5~ 84.5	6~ 84.5	20~ 84.5
標準フック	200t	200t	80t	80t	80t	80t
フック重量	3200kg	3200kg	1550kg	1550kg	1550kg	1550kg
補巻時 標準巻掛本数	11	8	6	5	4	3
主巻時 標準巻掛本数	8	6	6	5	4	3
主巻時 最大荷重	91.1	69.7	68.0	58.0	45.0	34.9

カウンタウエイト 58t、アウトリガ張出幅 8.0m

PS+ブーム

単位:t

ブーム長さ(m) 作業半径(m)	35.3	40.4	45.4	50.5	55.6	60.0
4.0	118.0					
4.5	118.0					
5.0	118.0					
6.0	118.0	84.2				
7.0	112.6	84.2	68.0			
8.0	101.4	84.2	68.0	58.0		
9.0	93.8	84.2	68.0	58.0	45.0	
10.0	86.3	82.4	68.0	58.0	45.0	34.9
11.0	76.2	76.8	68.0	58.0	45.0	34.8
12.0	65.0	66.7	67.8	58.0	44.8	34.6
14.0	49.4	51.0	51.9	53.1	44.4	34.2
16.0	39.0	40.4	41.3	42.5	43.4	33.8
18.0	31.5	32.9	33.8	34.9	35.8	33.4
20.0	26.0	27.3	28.1	29.2	30.0	30.1
22.0	21.6	22.9	23.7	24.7	25.6	25.6
24.0	18.2	19.4	20.2	21.2	22.0	22.1
26.0	15.4	16.6	17.4	18.3	19.1	19.2
28.0	13.0	14.2	15.0	15.9	16.7	16.8
30.0	10.8	12.2	12.9	13.9	14.6	14.7
32.0	8.9	10.2	11.2	12.1	12.9	12.9
34.0		8.5	9.5	10.6	11.4	11.4
36.0		7.1	8.0	9.1	10.0	10.1
38.0		5.8	6.7	7.8	8.8	8.8
40.0			5.5	6.6	7.6	7.7
42.0			4.5	5.6	6.5	6.6
44.0				4.7	5.6	5.6
46.0				3.8	4.7	4.8
48.0				3.1	3.9	4.0
50.0					3.2	3.3
52.0					2.6	2.7
θ(°)	4~ 84.5	5~ 84.5	4~ 84.5	5~ 84.5	6~ 84.5	25~ 84.5
標準フック	200t	200t	80t	80t	80t	80t
フック重量	3200kg	3200kg	1550kg	1550kg	1550kg	1550kg
補巻時 標準巻掛本数	11	8	6	5	4	3
主巻時 標準巻掛本数	8	6	6	5	4	3
主巻時 最大荷重	91.1	69.7	68.0	58.0	45.0	34.9

カウンタウエイト 58t、アウトリガ張出幅 6.8m

PS+ブーム

単位:t

ブーム長さ(m) 作業半径(m)	35.3	40.4	45.4	50.5	55.6	60.0
4.0	118.0					
4.5	118.0					
5.0	118.0					
6.0	118.0	84.2				
7.0	112.6	84.2	68.0			
8.0	101.4	84.2	68.0	58.0		
9.0	88.6	84.2	68.0	58.0	45.0	
10.0	73.2	75.0	68.0	58.0	45.0	34.9
11.0	61.8	63.5	64.5	58.0	45.0	34.8
12.0	53.1	54.7	55.7	56.8	44.8	34.6
14.0	40.6	42.1	43.0	44.1	44.4	34.2
16.0	32.1	33.5	34.3	35.4	36.3	33.8
18.0	25.9	27.2	28.1	29.1	30.0	30.0
20.0	21.2	22.5	23.3	24.3	25.1	25.2
22.0	17.5	18.8	19.6	20.5	21.4	21.4
24.0	14.6	15.8	16.6	17.5	18.3	18.4
26.0	12.0	13.3	14.1	15.0	15.8	15.9
28.0	9.7	11.2	12.0	12.9	13.7	13.8
30.0	7.8	9.2	10.1	11.2	11.9	12.0
32.0	6.1	7.5	8.4	9.6	10.4	10.5
34.0		6.0	6.9	8.1	9.0	9.1
36.0		4.7	5.6	6.7	7.7	7.8
38.0		3.6	4.5	5.6	6.5	6.6
40.0			3.5	4.5	5.5	5.5
42.0			2.5	3.6	4.5	4.6
44.0				2.8	3.7	3.8
46.0					2.9	3.0
θ(°)	4~ 84.5	5~ 84.5	4~ 84.5	23~ 84.5	30~ 84.5	38~ 84.5
標準フック	200t	200t	80t	80t	80t	80t
フック重量	3200kg	3200kg	1550kg	1550kg	1550kg	1550kg
補巻時 標準巻掛本数	11	8	6	5	4	3
主巻時 標準巻掛本数	8	6	6	5	4	3
主巻時 最大荷重	91.1	69.7	68.0	58.0	45.0	34.9

カウンタウエイト 47t、アウトリガ張出幅 8.5m

PS+ブーム

単位:t

ブーム長さ(m) 作業半径(m)	35.3	40.4	45.4	50.5	55.6	60.0
4.0	118.0					
4.5	118.0					
5.0	118.0					
6.0	118.0	84.2				
7.0	112.6	84.2	68.0			
8.0	101.4	84.2	68.0	58.0		
9.0	93.8	84.2	68.0	58.0	45.0	
10.0	81.9	82.4	68.0	58.0	45.0	34.9
11.0	69.0	70.7	68.0	58.0	45.0	34.8
12.0	59.1	60.8	61.8	58.0	44.8	34.6
14.0	45.1	46.7	47.6	48.7	44.4	34.2
16.0	35.7	37.1	38.0	39.1	40.0	33.8
18.0	28.7	30.1	31.0	32.1	33.0	33.0
20.0	23.4	24.7	25.6	26.6	27.5	27.6
22.0	19.3	20.6	21.4	22.4	23.3	23.3
24.0	16.0	17.3	18.1	19.1	19.9	20.0
26.0	13.4	14.6	15.4	16.3	17.2	17.2
28.0	11.0	12.3	13.1	14.1	14.9	14.9
30.0	8.9	10.3	11.2	12.2	12.9	13.0
32.0	7.1	8.4	9.4	10.5	11.3	11.4
34.0		6.9	7.8	9.0	9.9	9.9
36.0		5.5	6.4	7.6	8.5	8.6
38.0		4.3	5.2	6.3	7.3	7.4
40.0			4.1	5.2	6.2	6.3
42.0			3.2	4.3	5.2	5.3
44.0				3.4	4.3	4.4
46.0				2.6	3.5	3.6
48.0					2.8	2.8
θ(°)	4~ 84.5	5~ 84.5	4~ 84.5	14~ 84.5	25~ 84.5	34~ 84.5
標準フック	200t	200t	80t	80t	80t	80t
フック重量	3200kg	3200kg	1550kg	1550kg	1550kg	1550kg
補巻時 標準巻掛本数	11	8	6	5	4	3
主巻時 標準巻掛本数	8	6	6	5	4	3
主巻時 最大荷重	91.1	69.7	68.0	58.0	45.0	34.9

カウンタウエイト 47t、アウトリガ張出幅 8.0m

PS+ブーム		単位:t					
ブーム長さ(m)	作業半径(m)	35.3	40.4	45.4	50.5	55.6	60.0
4.0	118.0						
4.5	118.0						
5.0	118.0						
6.0	118.0	84.2					
7.0	112.6	84.2	68.0				
8.0	101.4	84.2	68.0	58.0			
9.0	93.8	84.2	68.0	58.0	45.0		
10.0	79.1	81.1	68.0	58.0	45.0	34.9	
11.0	65.9	67.8	68.0	58.0	45.0	34.8	
12.0	56.1	57.8	58.8	58.0	44.8	34.6	
14.0	42.2	43.8	44.7	45.9	44.4	34.2	
16.0	33.0	34.5	35.4	36.5	37.4	33.8	
18.0	26.4	27.8	28.7	29.7	30.6	30.7	
20.0	21.5	22.8	23.7	24.7	25.6	25.6	
22.0	17.7	18.9	19.8	20.8	21.6	21.7	
24.0	14.6	15.8	16.6	17.6	18.4	18.5	
26.0	12.0	13.3	14.1	15.1	15.9	15.9	
28.0	9.7	11.1	12.0	12.9	13.7	13.8	
30.0	7.7	9.1	10.1	11.1	11.9	11.9	
32.0	6.0	7.4	8.3	9.5	10.3	10.4	
34.0		5.9	6.8	8.0	8.9	9.0	
36.0		4.6	5.5	6.6	7.6	7.7	
38.0		3.4	4.3	5.5	6.4	6.5	
40.0			3.3	4.4	5.3	5.4	
42.0			2.4	3.5	4.4	4.5	
44.0				2.7	3.6	3.6	
46.0					2.8	2.9	
$\theta (^{\circ})$		4~84.5	5~84.5	4~84.5	23~84.5	30~84.5	38~84.5
標準フック		200t	200t	80t	80t	80t	80t
フック重量		3200kg	3200kg	1550kg	1550kg	1550kg	1550kg
補巻時標準巻掛本数		11	8	6	5	4	3
主巻時標準巻掛本数		8	6	6	5	4	3
主巻時最大荷重		91.1	69.7	68.0	58.0	45.0	34.9

カウンタウエイト 47t、アウトリガ張出幅 6.8m

PS+ブーム		単位:t					
ブーム長さ(m)	作業半径(m)	35.3	40.4	45.4	50.5	55.6	60.0
4.0	118.0						
4.5	118.0						
5.0	118.0						
6.0	118.0	84.2					
7.0	112.6	84.2	68.0				
8.0	96.3	84.2	68.0	58.0			
9.0	76.7	78.6	68.0	58.0	45.0		
10.0	63.1	64.9	65.9	58.0	45.0	34.9	
11.0	53.1	54.7	55.7	57.0	45.0	34.8	
12.0	45.4	47.0	47.9	49.1	44.8	34.6	
14.0	34.3	35.8	36.7	37.8	38.8	34.2	
16.0	26.8	28.2	29.1	30.1	31.0	31.1	
18.0	21.3	22.7	23.5	24.5	25.4	25.5	
20.0	17.2	18.5	19.3	20.3	21.1	21.2	
22.0	14.0	15.2	16.0	17.0	17.8	17.8	
24.0	11.2	12.5	13.3	14.3	15.1	15.1	
26.0	8.8	10.2	11.1	12.1	12.9	12.9	
28.0	6.7	8.2	9.1	10.2	11.0	11.1	
30.0	5.0	6.4	7.4	8.5	9.4	9.5	
32.0	3.5	4.9	5.8	7.0	7.9	8.0	
34.0		3.6	4.5	5.6	6.6	6.7	
36.0		2.4	3.4	4.5	5.4	5.5	
38.0				3.4	4.4	4.4	
40.0				2.5	3.4	3.5	
42.0					2.6	2.7	
$\theta (^{\circ})$		4~84.5	13~84.5	32~84.5	34~84.5	39~84.5	44~84.5
標準フック		200t	200t	80t	80t	80t	80t
フック重量		3200kg	3200kg	1550kg	1550kg	1550kg	1550kg
補巻時標準巻掛本数		11	8	6	5	4	3
主巻時標準巻掛本数		8	6	6	5	4	3
主巻時最大荷重		91.1	69.7	68.0	58.0	45.0	34.9

カウンタウエイト 25t、アウトリガ張出幅 8.5m

PS+ブーム		単位:t					
ブーム長さ(m)	作業半径(m)	35.3	40.4	45.4	50.5	55.6	60.0
4.0	118.0						
4.5	118.0						
5.0	118.0						
6.0	118.0	84.2					
7.0	112.6	84.2	68.0				
8.0	94.8	84.2	68.0	58.0			
9.0	74.6	76.6	68.0	58.0	45.0		
10.0	60.7	62.6	63.7	58.0	45.0	34.9	
11.0	50.6	52.4	53.4	54.7	45.0	34.8	
12.0	42.4	44.1	45.2	46.5	44.8	34.6	
14.0	31.0	32.6	33.6	34.8	35.8	34.2	
16.0	23.5	25.0	25.9	27.0	28.0	28.1	
18.0	18.2	19.6	20.5	21.6	22.5	22.5	
20.0	14.2	15.6	16.4	17.5	18.3	18.4	
22.0	11.1	12.4	13.3	14.3	15.1	15.2	
24.0	8.3	9.9	10.8	11.8	12.6	12.7	
26.0	6.1	7.6	8.6	9.7	10.5	10.6	
28.0	4.2	5.7	6.7	7.9	8.8	8.9	
30.0		4.0	5.0	6.2	7.2	7.3	
32.0		2.7	3.6	4.8	5.8	5.9	
34.0			2.4	3.6	4.5	4.6	
36.0				2.5	3.5	3.5	
38.0					2.5		
$\theta (^{\circ})$		29~84.5	31~84.5	37~84.5	42~84.5	45~84.5	52~84.5
標準フック		200t	200t	80t	80t	80t	80t
フック重量		3200kg	3200kg	1550kg	1550kg	1550kg	1550kg
補巻時標準巻掛本数		11	8	6	5	4	3
主巻時標準巻掛本数		8	6	6	5	4	3
主巻時最大荷重		91.1	69.7	68.0	58.0	45.0	34.9

カウンタウエイト 25t、アウトリガ張出幅 8.0m

PS+ブーム		単位:t					
ブーム長さ(m)	作業半径(m)	35.3	40.4	45.4	50.5	55.6	60.0
4.0	118.0						
4.5	118.0						
5.0	118.0						
6.0	118.0	84.2					
7.0	112.6	84.2	68.0				
8.0	90.3	84.2	68.0	58.0			
9.0	69.6	71.7	68.0	58.0	45.0		
10.0	55.8	57.7	58.9	58.0	45.0	34.9	
11.0	45.9	47.7	48.8	50.2	45.0	34.8	
12.0	38.6	40.3	41.3	42.6	43.6	34.6	
14.0	28.2	29.8	30.7	31.9	32.9	33.0	
16.0	21.3	22.8	23.7	24.8	25.7	25.8	
18.0	16.4	17.8	18.7	19.7	20.6	20.7	
20.0	12.7	14.1	14.9	15.9	16.8	16.9	
22.0	9.7	11.2	12.0	13.0	13.8	13.9	
24.0	7.1	8.6	9.6	10.6	11.4	11.5	
26.0	4.9	6.5	7.5	8.7	9.5	9.6	
28.0		4.6	5.6	6.8	7.8	7.9	
30.0		3.1	4.1	5.3	6.2	6.3	
32.0			2.8	3.9	4.9	5.0	
34.0				2.8	3.7	3.8	
36.0					2.7		
$\theta (^{\circ})$		36~84.5	37~84.5	41~84.5	46~84.5	48~84.5	55~84.5
標準フック		200t	200t	80t	80t	80t	80t
フック重量		3200kg	3200kg	1550kg	1550kg	1550kg	1550kg
補巻時標準巻掛本数		11	8	6	5	4	3
主巻時標準巻掛本数		8	6	6	5	4	3
主巻時最大荷重		91.1	69.7	68.0	58.0	45.0	34.9

PS+ブーム

カウンタウエイト 25t、アウトリガ張出幅 6.8m

PS+ブーム		単位:t					
ブーム長さ(m)	作業半径(m)	35.3	40.4	45.4	50.5	55.6	60.0
4.0	118.0						
4.5	118.0						
5.0	118.0						
6.0	118.0	84.2					
7.0	90.6	84.2	68.0				
8.0	68.0	70.1	68.0	58.0			
9.0	53.5	55.4	56.5	57.9	45.0		
10.0	43.4	45.2	46.2	47.5	45.0	34.9	
11.0	36.0	37.6	38.6	39.9	40.9	34.8	
12.0	30.3	31.8	32.8	34.0	35.0	34.6	
14.0	22.1	23.5	24.4	25.6	26.5	26.6	
16.0	16.5	17.9	18.7	19.8	20.7	20.8	
18.0	12.4	13.8	14.6	15.6	16.5	16.5	
20.0	9.1	10.6	11.5	12.5	13.3	13.3	
22.0	6.4	7.9	8.9	10.0	10.8	10.8	
24.0		5.7	6.7	7.9	8.8	8.8	
26.0		3.8	4.8	6.0	7.0	7.0	
28.0			3.2	4.4	5.4	5.4	
30.0					4.0		
$\theta (^{\circ})$		46~84.5	46~84.5	49~84.5	55~84.5	57~84.5	62~84.5
標準フック		200t	200t	80t	80t	80t	80t
フック重量		3200kg	3200kg	1550kg	1550kg	1550kg	1550kg
補巻時 標準巻掛本数		11	8	6	5	4	3
主巻時 標準巻掛本数		8	6	6	5	4	3
主巻時 最大荷重		91.1	69.7	68.0	58.0	45.0	34.9

カウンタウエイト 0t、アウトリガ張出幅 8.5m

PS+ブーム		単位:t		
ブーム長さ(m)	作業半径(m)	15.0	20.1	25.1
3.0	30.0	30.0	30.0	30.0
3.5	30.0	30.0	30.0	30.0
4.0	30.0	30.0	30.0	30.0
4.5	30.0	30.0	30.0	30.0
5.0	30.0	30.0	30.0	30.0
6.0	30.0	30.0	30.0	30.0
7.0	30.0	30.0	30.0	30.0
8.0	30.0	30.0	30.0	30.0
9.0	30.0	30.0	30.0	30.0
10.0	25.2	29.4	29.9	
11.0	18.7	23.8	25.0	
12.0	13.5	18.8	20.7	
14.0		11.7	14.2	
16.0		7.1	9.6	
18.0		3.2	6.4	
20.0			3.8	
22.0			1.6	
$\theta (^{\circ})$		0~79	0~84.5	0~84.5
標準フック		80t	80t	80t
フック重量		1550kg	1550kg	1550kg
補巻時 標準巻掛本数		3	3	3
主巻時 標準巻掛本数		3	3	3
主巻時 最大荷重		30.0	30.0	30.0

カウンタウエイト 0t、アウトリガ張出幅 8.0m

PS+ブーム		単位:t		
ブーム長さ(m)	作業半径(m)	15.0	20.1	25.1
3.0	30.0	30.0	30.0	30.0
3.5	30.0	30.0	30.0	30.0
4.0	30.0	30.0	30.0	30.0
4.5	30.0	30.0	30.0	30.0
5.0	30.0	30.0	30.0	30.0
6.0	30.0	30.0	30.0	30.0
7.0	30.0	30.0	30.0	30.0
8.0	30.0	30.0	30.0	30.0
9.0	29.2	30.0	30.0	
10.0	21.7	25.8	26.5	
11.0	16.4	20.9	22.2	
12.0	12.3	16.8	18.7	
14.0		10.9	13.2	
16.0		6.8	9.2	
18.0		3.2	6.3	
20.0			3.8	
22.0			1.6	
$\theta (^{\circ})$		0~79	0~84.5	0~84.5
標準フック		80t	80t	80t
フック重量		1550kg	1550kg	1550kg
補巻時 標準巻掛本数		3	3	3
主巻時 標準巻掛本数		3	3	3
主巻時 最大荷重		30.0	30.0	30.0

カウンタウエイト 0t、アウトリガ張出幅 6.8m

PS+ブーム		単位:t		
ブーム長さ(m)	作業半径(m)	15.0	20.1	25.1
3.0	30.0	30.0	30.0	30.0
3.5	30.0	30.0	30.0	30.0
4.0	30.0	30.0	30.0	30.0
4.5	30.0	30.0	30.0	30.0
5.0	30.0	30.0	30.0	30.0
6.0	30.0	30.0	30.0	30.0
7.0	30.0	30.0	30.0	30.0
8.0	26.7	28.8	28.9	
9.0	19.9	22.8	23.5	
10.0	14.6	18.2	19.3	
11.0	10.6	14.7	15.9	
12.0	7.0	11.6	13.2	
14.0		7.0	9.1	
16.0		3.3	6.0	
18.0			3.3	
20.0			1.2	
$\theta (^{\circ})$		0~79	0~84.5	0~84.5
標準フック		80t	80t	80t
フック重量		1550kg	1550kg	1550kg
補巻時 標準巻掛本数		3	3	3
主巻時 標準巻掛本数		3	3	3
主巻時 最大荷重		30.0	30.0	30.0

フルオートラフィングジブ

ブーム+フルオートラフィングジブ(FLJ)作業半径－揚程図

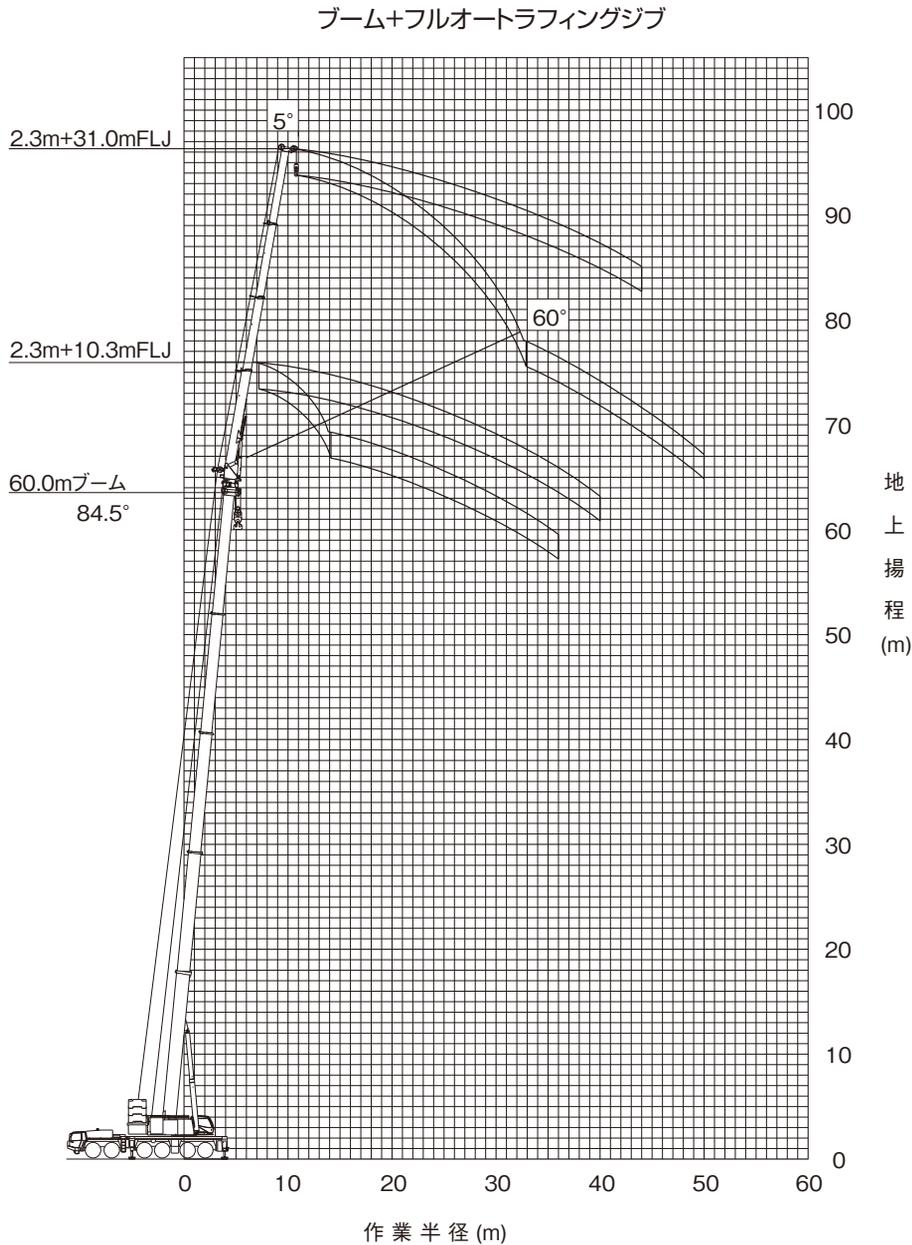

(注意)

- ◆ 上図はブームおよびジブのたわみを含んでいません。
- ◆ カウンタウエイト118t、アウトリガ張出幅8.5m または8.0mの性能を図示しています。

ブーム+フルオートラフィングジブ(FLJ)定格総荷重表

■ 定格総荷重表注意事項

◆性能設定のあるカウンタウエイトとアウトリガ張出幅の組合せを、下表に○印で示します。

アウトリガ張出幅	カウンタウエイト	118 t	98 t	78 t	58 t	47 t	25 t
8.5 m		○	○	○	○	○	○
8.0 m		○	○	○	○	○	○
6.8 m				○	○	○	

◆定格総荷重は、つり具質量とフック質量(80トンフック:1,550kg、35トンフック:950kg、12.2トンフック:440kg)を含んだ値を示します。

◆定格総荷重は、ブームとジブのたわみを含んだ実際の作業半径に基づいています。

◆各ブーム長さにおける各伸縮ブームの伸長状態(伸長割合%)は、下表のとおりです。

ブーム長さ	40.4 m	45.4 m	50.5 m	55.6 m	60.0 m
伸縮ブーム1	90	90	90	90	100
伸縮ブーム2	90	90	90	90	100
伸縮ブーム3	45	90	90	90	100
伸縮ブーム4	0	0	45	90	100

◆Bピン(ブーム固定ピン)を挿入していないときの定格総荷重は、24.9t以下になります。

◆定格総荷重表中の標準巻掛本数よりも少ない本数で使用する場合、最大荷重の上限は下表のとおりです。

巻掛本数	3本	2本	1本
最大荷重	35.9t	24.1t	12.2t

◆定格総荷重は、アウトリガを水平堅土上に設置したときの値です。

◆定格総荷重表は、風による影響を含んでいません。瞬間最大風速が10m/s以上の風速では、クレーン作業を中止してください。

定格総荷重表中の線、および用語説明

◆太線より上側はクレーンの強度に、下側はクレーンの安定に基づいています。

◆「オフセット」はブームの中心線とジブの中心線とのなす角度を示します。

◆「 θ (°)」は、無負荷状態で作動可能なブーム起伏角度範囲を示します。

フルオートラフィングジブ

カウンタウエイト 118t、アウトリガ張出幅 8.5m、または 8.0m
40.4mブーム+2.3m+フルオートラフィングジブ

単位:t

ジブ長さ(m) 作業半径 (m)	10.3m オフセット					17.2m オフセット					24.1m オフセット					31.0m オフセット				
	5°	15°	30°	45°	60°	5°	15°	30°	45°	60°	5°	15°	30°	45°	60°	5°	15°	30°	45°	60°
9.0	38.4																			
10.0	36.0					16.7														
11.0	33.8	31.6				16.7														
12.0	31.9	30.2				16.7														
14.0	28.6	27.3	25.2			16.7	16.7				16.0									
16.0	25.8	24.8	23.5	22.1	21.1	16.7	16.7				15.5					10.9				
18.0	23.5	22.6	21.6	20.9	20.3	16.7	16.7	16.7			15.0	13.5				10.8				
20.0	21.5	20.8	19.9	19.4	19.0	16.7	16.7	15.9			14.5	13.0				10.5				
22.0	19.8	19.2	18.5	18.0	17.7	16.7	16.7	15.2	14.0		13.9	12.5				10.3	9.2			
24.0	18.3	17.8	17.2	16.8	16.6	16.7	16.2	14.5	13.4	12.9	13.4	12.1	10.8			10.0	8.8			
26.0	17.0	16.5	16.0	15.7	15.5	15.9	15.4	13.9	13.0	12.5	12.9	11.7	10.5			9.7	8.4			
28.0	15.8	15.4	15.0	14.7	14.6	14.8	14.4	13.3	12.5	12.1	12.5	11.4	10.1	9.3		9.2	8.1			
30.0	13.9	14.2	14.0	13.8		13.9	13.5	12.8	12.1	11.8	12.1	11.1	9.8	9.0	8.5	8.8	7.8	6.7		
32.0	12.1	12.4	12.7	12.9		13.0	12.6	12.2	11.8	11.6	11.7	10.8	9.6	8.8	8.4	8.5	7.5	6.5		
34.0	10.5	10.8	11.1	11.2		11.9	11.9	11.5	11.3	11.2	11.3	10.4	9.3	8.6	8.3	8.1	7.2	6.2		
36.0	9.1	9.4	9.6	9.7		10.5	11.0	10.9	10.7	10.6	10.9	10.0	9.0	8.5	8.2	7.8	6.9	6.1	5.5	
38.0	7.9	8.1	8.3	8.4		9.3	9.7	10.1	10.1		10.2	9.6	8.8	8.3	8.1	7.5	6.7	5.9	5.3	
40.0	6.7	6.9	7.1			8.2	8.5	9.0	9.2		9.1	9.3	8.5	8.1	8.0	7.2	6.5	5.7	5.2	5.0
42.0	5.7	5.9	6.0			7.1	7.5	7.9	8.1		8.1	8.5	8.2	7.9		7.0	6.3	5.5	5.1	5.0
44.0	4.8	4.9	5.0			6.2	6.5	6.9	7.0		7.2	7.7	8.0	7.7		6.7	6.1	5.4	5.0	4.9
46.0	3.9	4.0				5.3	5.6	5.9			6.3	6.8	7.3	7.4		6.5	5.9	5.3	4.9	4.8
48.0	3.1	3.2				4.6	4.8	5.0			5.6	6.0	6.5	6.7		6.3	5.7	5.1	4.8	
50.0						3.8	4.0	4.2			4.9	5.2	5.7	5.9		5.9	5.6	5.0	4.7	
54.0						2.6	2.7				3.6	3.9	4.2			4.6	5.0	4.8	4.6	
58.0											2.5	2.7	2.9			3.5	3.9	4.3		
62.0											1.5	1.7				2.5	2.8	3.1		
66.0																1.7	1.9			
θ (°)	22~ 84.5	23~ 84.5	36~ 84.5	48~ 84.5	64~ 84.5	26~ 84.5	28~ 84.5	39~ 84.5	52~ 84.5	65~ 84.5	21~ 84.5	24~ 84.5	37~ 84.5	53~ 84.5	69~ 84.5	28~ 84.5	32~ 84.5	44~ 84.5	59~ 84.5	72~ 84.5
標準フック											35t					12.2t				
フック重量	80t										950kg					440kg				
標準巻掛本数	4										2					1				

カウンタウエイト 118t、アウトリガ張出幅 8.5m、または 8.0m
45.4mブーム+2.3m+フルオートラフィングジブ

単位:t

ジブ長さ(m) 作業半径 (m)	10.3m オフセット					17.2m オフセット					24.1m オフセット					31.0m オフセット				
	5°	15°	30°	45°	60°	5°	15°	30°	45°	60°	5°	15°	30°	45°	60°	5°	15°	30°	45°	60°
10.0	29.5																			
11.0	27.8																			
12.0	26.3	24.5				16.7														
14.0	23.6	22.2	20.6			16.7					15.3									
16.0	21.4	20.3	19.0	18.0		16.7	16.7				14.8					10.4				
18.0	19.6	18.6	17.5	16.7	16.2	16.7	16.7				14.4					10.3				
20.0	18.0	17.2	16.2	15.6	15.1	16.4	15.4	14.3			14.0	12.8				10.1				
22.0	16.6	15.9	15.1	14.5	14.2	15.2	14.3	13.3			13.7	12.4				9.9	9.0			
24.0	15.4	14.8	14.1	13.6	13.3	14.1	13.3	12.5	11.9		13.0	12.0				9.6	8.7			
26.0	14.3	13.8	13.2	12.8	12.6	13.1	12.4	11.7	11.2	10.8	12.1	11.4	10.4			9.4	8.3			
28.0	13.4	12.9	12.4	12.0	11.9	12.2	11.6	11.0	10.5	10.2	11.3	10.7	9.9			9.2	8.0			
30.0	12.2	12.1	11.6	11.3	11.2	11.4	10.9	10.3	9.9	9.7	10.6	10.0	9.4	8.8		8.8	7.7	6.6		
32.0	10.9	10.9	10.8	10.7		10.7	10.2	9.7	9.4	9.2	9.9	9.4	8.9	8.5	8.2	8.4	7.4	6.4		
34.0	9.8	9.8	9.7	9.7		10.0	9.6	9.2	8.9	8.7	9.3	8.9	8.4	8.1	7.9	8.1	7.2	6.2		
36.0	8.4	8.7	8.8	8.7		9.1	9.1	8.7	8.4	8.3	8.8	8.4	7.9	7.7	7.5	7.8	6.9	6.0	5.5	
38.0	7.2	7.4	7.7	7.8		8.2	8.2	8.0	7.8	7.7	8.2	7.9	7.5	7.2	7.0	7.5	6.7	5.8	5.3	
40.0	6.0	6.3	6.5	6.6		7.4	7.4	7.4	7.3		7.5	7.2	6.9	6.7	6.5	7.2	6.5	5.7	5.2	5.0
42.0	5.0	5.2	5.5			6.4	6.7	6.8	6.7		6.9	6.7	6.4	6.2	6.1	6.9	6.3	5.5	5.1	4.9
44.0	4.1	4.3	4.5			5.5	5.8	6.1	6.1		6.2	6.2	5.9	5.8		6.3	6.1	5.4	5.0	4.8
46.0	3.2	3.4	3.5			4.6	5.0	5.4	5.5		5.6	5.7	5.5	5.3		5.8	5.7	5.2	4.9	4.8
48.0	2.5	2.6	2.7			3.8	4.2	4.5	4.6		4.9	5.2	5.1	4.9		5.4	5.2	5.0	4.8	4.7
50.0	1.8	1.9				3.1	3.4	3.7			4.2	4.6	4.7	4.6		5.0	4.8	4.7	4.5	
54.0						1.9	2.1	2.2			2.9	3.3	3.7			3.9	4.1	4.0	3.9	
58.0											1.8	2.1	2.4			2.8	3.3	3.3	3.3	
62.0																1.9	2.3	2.7		
66.0																		1.7		
θ (°)	30~ 84.5	31~ 84.5	36~ 84.5	51~ 84.5	66~ 84.5	36~ 84.5	38~ 84.5	39~ 84.5	50~ 84.5	65~ 84.5	38~ 84.5	42~ 84.5	46~ 84.5	60~ 84.5	71~ 84.5	41~ 84.5	46~ 84.5	44~ 84.5	58~ 84.5	72~ 84.5
標準フック											35t					12.2t				
フック重量	950kg										950kg					440kg				
標準巻掛本数	3										2					1				

カウンタウエイト 118t、アウトリガ張出幅 8.5m、または 8.0m
50.5mブーム+2.3m+フルオートラフィングジブ

単位:t

ジブ長さ(m) 作業半径 (m)	10.3m オフセット					17.2m オフセット					24.1m オフセット					31.0m オフセット				
	5°	15°	30°	45°	60°	5°	15°	30°	45°	60°	5°	15°	30°	45°	60°	5°	15°	30°	45°	60°
11.0	21.2																			
12.0	20.0																			
14.0	17.8	16.8				16.5														
16.0	16.0	15.2	14.2			15.0					13.5									
18.0	14.5	13.9	13.1	12.4	11.9	13.6	12.5				12.4					9.1				
20.0	13.2	12.7	12.1	11.6	11.2	12.5	11.7				11.5					9.1				
22.0	12.1	11.6	11.1	10.7	10.5	11.4	10.8	9.8			10.7	9.6				9.1				
24.0	11.1	10.7	10.3	10.0	9.7	10.5	10.0	9.2	8.5		9.9	9.0				9.1	8.3			
26.0	10.2	9.9	9.5	9.2	9.1	9.7	9.3	8.7	8.1	7.7	9.1	8.5	7.5			8.7	7.8			
28.0	9.3	9.0	8.7	8.5	8.3	9.0	8.6	8.2	7.7	7.4	8.5	8.0	7.1			8.2	7.4			
30.0	8.3	8.1	7.8	7.6	7.5	8.2	7.9	7.6	7.4	7.1	7.8	7.5	6.8			7.7	7.0			
32.0	7.4	7.2	7.0	6.9	6.7	7.3	7.1	6.9	6.7	6.6	7.1	6.9	6.4	6.0		7.2	6.6	5.9		
34.0	6.6	6.4	6.3	6.1		6.5	6.4	6.2	6.1	6.0	6.4	6.2	6.1	5.7	5.4	6.6	6.3	5.6		
36.0	5.8	5.7	5.6	5.5		5.9	5.7	5.6	5.5	5.4	5.7	5.6	5.5	5.4	5.2	5.9	5.8	5.3		
38.0	5.1	5.1	4.9	4.9		5.2	5.1	5.0	4.9	4.9	5.1	5.0	5.0	4.9	4.8	5.3	5.3	5.1	4.7	
40.0	4.5	4.5	4.4	4.3		4.6	4.6	4.5	4.4	4.4	4.6	4.5	4.5	4.4	4.4	4.8	4.8	4.7	4.5	
42.0	4.0	3.9	3.8	3.8		4.1	4.1	4.0	4.0		4.1	4.0	4.0	4.0	3.9	4.3	4.3	4.3	4.2	4.0
44.0	3.5	3.4	3.4	3.3		3.6	3.6	3.6	3.5		3.6	3.6	3.6	3.6	3.5	3.9	3.9	3.9	3.9	3.7
46.0	2.8	2.9	2.9			3.2	3.1	3.1	3.1		3.2	3.2	3.2	3.2		3.4	3.5	3.5	3.5	3.5
48.0	2.1	2.2	2.4			2.7	2.7	2.7	2.7		2.8	2.8	2.8	2.8		3.0	3.1	3.1	3.1	3.1
50.0		1.5	1.6			2.4	2.4	2.4	2.3		2.4	2.4	2.5	2.5		2.7	2.7	2.8	2.8	2.8
54.0						1.5	1.7	1.7			1.7	1.8	1.8	1.8		2.0	2.1	2.2	2.2	
58.0																1.5	1.6	1.6		
θ(°)	41~ 84.5	39~ 84.5	40~ 84.5	50~ 84.5	66~ 84.5	41~ 84.5	43~ 84.5	46~ 84.5	52~ 84.5	66~ 84.5	48~ 84.5	52~ 84.5	55~ 84.5	57~ 84.5	70~ 84.5	54~ 84.5	54~ 84.5	59~ 84.5	62~ 84.5	73~ 84.5
標準フック																35t				
フック重量																950kg				
標準巻掛本数																2				

カウンタウエイト 118t、アウトリガ張出幅 8.5m、または 8.0m
55.6mブーム+2.3m+フルオートラフィングジブ

単位:t

ジブ長さ(m) 作業半径 (m)	10.3m オフセット					17.2m オフセット					24.1m オフセット					31.0m オフセット				
	5°	15°	30°	45°	60°	5°	15°	30°	45°	60°	5°	15°	30°	45°	60°	5°	15°	30°	45°	60°
12.0	14.6																			
14.0	14.6	14.5																		
16.0	13.9	13.2				12.0														
18.0	12.5	12.1	11.2			11.6	10.7				9.4									
20.0	11.3	11.0	10.4	9.9	9.5	10.7	9.8				9.4					6.4				
22.0	10.3	10.0	9.6	9.2	8.9	9.8	9.1	8.3			9.3	8.5				6.4				
24.0	9.3	9.1	8.8	8.6	8.4	8.9	8.5	7.8			8.6	7.9				6.4				
26.0	8.1	8.0	7.8	7.7	7.5	8.0	7.9	7.3	6.9		8.0	7.4				6.4	6.4			
28.0	7.0	6.9	6.8	6.7	6.6	7.0	6.9	6.8	6.5	6.2	7.3	6.9	6.3			6.4	6.4			
30.0	6.1	6.0	6.0	5.9	5.8	6.1	6.1	6.1	6.0	5.9	6.5	6.5	5.9			6.4	6.0			
32.0	5.2	5.2	5.2	5.1	5.0	5.3	5.3	5.3	5.3	5.3	5.7	5.7	5.6			5.8	5.6			
34.0	4.5	4.5	4.4	4.4	4.3	4.6	4.6	4.7	4.7	4.6	5.0	5.1	4.9			5.1	5.2	4.9		
36.0	3.8	3.8	3.8	3.7	3.7	3.9	4.0	4.1	4.1	4.0	4.4	4.5	4.6	4.5	4.3	4.5	4.6	4.5		
38.0	3.1	3.1	3.2	3.1		3.3	3.4	3.5	3.5	3.5	3.8	3.9	4.0	4.1	4.0	3.9	4.1	4.1		
40.0	2.5	2.6	2.6	2.6		2.8	2.9	3.0	3.0	3.0	3.2	3.4	3.5	3.6	3.6	3.4	3.6	3.7	3.5	
42.0	2.0	2.0	2.1	2.0		2.3	2.4	2.5	2.5	2.5	2.7	2.9	3.0	3.1	3.1	3.0	3.1	3.3	3.2	
44.0	1.5	1.5	1.6	1.6		1.8	1.9	2.0	2.1		2.3	2.4	2.6	2.7	2.7	2.5	2.7	2.9	2.9	2.8
46.0							1.5	1.6	1.6		1.9	2.0	2.2	2.3	2.3	2.1	2.3	2.5	2.6	2.6
48.0											1.5	1.6	1.8	1.9		1.7	1.9	2.1	2.3	2.3
50.0														1.5				1.8	1.9	2.0
θ(°)	51~ 84.5	53~ 84.5	54~ 84.5	55~ 84.5	64~ 84.5	57~ 84.5	57~ 84.5	60~ 84.5	61~ 84.5	66~ 84.5	58~ 84.5	61~ 84.5	65~ 84.5	66~ 84.5	71~ 84.5	63~ 84.5	64~ 84.5	69~ 84.5	73~ 84.5	75~ 84.5
標準フック																35t				
フック重量																950kg				
標準巻掛本数																2				

フルオートラフィングジブ

カウンタウエイト 118t、アウトリガ張出幅 8.5m、または 8.0m
60.0mブーム+2.3m+フルオートラフィングジブ

単位:t

ジブ長さ(m) 作業半径 (m)	10.3m オフセット					17.2m オフセット					24.1m オフセット					31.0m オフセット				
	5°	15°	30°	45°	60°	5°	15°	30°	45°	60°	5°	15°	30°	45°	60°	5°	15°	30°	45°	60°
14.0	12.0																			
16.0	12.0	11.6				8.0														
18.0	11.0	10.6	9.9			8.0					7.1									
20.0	9.9	9.6	9.2	8.8		8.0	8.0				7.1					5.7				
22.0	8.9	8.7	8.5	8.1	7.9	8.0	8.0				7.1					5.7				
24.0	7.7	7.7	7.6	7.5	7.3	8.0	7.7	7.2			7.1	6.9				5.7				
26.0	6.7	6.6	6.6	6.5	6.4	7.1	7.1	6.7			7.1	6.6				5.7				
28.0	5.7	5.7	5.7	5.6	5.5	6.1	6.2	6.2	5.9		6.3	6.2				5.7				
30.0	4.8	4.8	4.8	4.8	4.7	5.3	5.4	5.4	5.4	5.4	5.5	5.6	5.3			5.6	5.2			
32.0	4.0	4.1	4.1	4.1	4.0	4.5	4.6	4.7	4.8	4.7	4.7	4.9	4.9			4.9	4.9			
34.0	3.3	3.4	3.4	3.4	3.3	3.9	4.0	4.1	4.1	4.1	4.1	4.2	4.4	4.2		4.3	4.4			
36.0	2.7	2.7	2.8	2.8	2.7	3.2	3.3	3.5	3.5	3.5	3.5	3.6	3.8	3.9		3.7	3.9	3.6		
38.0	2.1	2.1	2.2	2.2		2.6	2.8	2.9	3.0	3.0	2.9	3.1	3.3	3.4	3.4	3.2	3.4	3.3		
40.0	1.5	1.6	1.7	1.7		2.1	2.3	2.4	2.5	2.5	2.4	2.6	2.8	3.0	3.0	2.7	2.9	3.0		
42.0						1.6	1.8	1.9	2.0	2.0	1.9	2.1	2.4	2.5	2.5	2.2	2.5	2.7	2.6	
44.0								1.5	1.6		1.5	1.7	2.0	2.1	2.1	1.8	2.0	2.3	2.4	
46.0													1.6	1.7	1.7		1.7	2.0	2.1	2.2
48.0																	1.6	1.8		1.8
50.0																				1.5
θ (°)	59~ 84.5	60~ 84.5	62~ 84.5	63~ 84.5	67~ 84.5	62~ 84.5	64~ 84.5	65~ 84.5	66~ 84.5	69~ 84.5	64~ 84.5	66~ 84.5	69~ 84.5	72~ 84.5	73~ 84.5	68~ 84.5	69~ 84.5	72~ 84.5	76~ 84.5	77~ 84.5
標準フック	12.2t																			
フック重量	440kg																			
標準巻掛本数	1																			

カウンタウエイト 98t、アウトリガ張出幅 8.5m
40.4mブーム+2.3m+フルオートラフィングジブ

単位:t

ジブ長さ(m) 作業半径 (m)	10.3m オフセット					17.2m オフセット					24.1m オフセット					31.0m オフセット														
	5°	15°	30°	45°	60°	5°	15°	30°	45°	60°	5°	15°	30°	45°	60°	5°	15°	30°	45°	60°										
9.0	38.4																													
10.0	36.0					16.7																								
11.0	33.8	31.6				16.7																								
12.0	31.9	30.2				16.7																								
14.0	28.6	27.3	25.2			16.7	16.7				16.0																			
16.0	25.8	24.8	23.5	22.1	21.1	16.7	16.7				15.5					10.9														
18.0	23.5	22.6	21.6	20.9	20.3	16.7	16.7	16.7			15.0	13.5				10.8														
20.0	21.5	20.8	19.9	19.4	19.0	16.7	16.7	15.9			14.5	13.0				10.5														
22.0	19.8	19.2	18.5	18.0	17.7	16.7	16.7	15.2	14.0		13.9	12.5				10.3	9.2													
24.0	18.3	17.8	17.2	16.8	16.6	16.7	16.2	14.5	13.4	12.9	13.4	12.1	10.8			10.0	8.8													
26.0	17.0	16.5	16.0	15.7	15.5	15.9	15.4	13.9	13.0	12.5	12.9	11.7	10.5			9.7	8.4													
28.0	15.8	15.4	15.0	14.7	14.6	14.8	14.4	13.3	12.5	12.1	12.5	11.4	10.1	9.3		9.2	8.1													
30.0	13.9	14.2	14.0	13.8		13.9	13.5	12.8	12.1	11.8	12.1	11.1	9.8	9.0	8.5	8.8	7.8	6.7												
32.0	12.1	12.4	12.7	12.9		13.0	12.6	12.2	11.8	11.6	11.7	10.8	9.6	8.8	8.4	8.5	7.5	6.5												
34.0	10.5	10.8	11.1	11.2		11.9	11.9	11.5	11.3	11.2	11.3	10.4	9.3	8.6	8.3	8.1	7.2	6.2												
36.0	9.1	9.4	9.6	9.7		10.5	11.0	10.9	10.7	10.6	10.9	10.0	9.0	8.5	8.2	7.8	6.9	6.1	5.5											
38.0	7.9	8.1	8.3	8.4		9.3	9.7	10.1	10.1		10.2	9.6	8.8	8.3	8.1	7.5	6.7	5.9	5.3											
40.0	6.4	6.8	7.1			8.2	8.5	9.0	9.2		9.1	9.3	8.5	8.1	8.0	7.2	6.5	5.7	5.2	5.0										
42.0	4.9	5.2	5.5			7.1	7.5	7.9	8.1		8.1	8.5	8.2	7.9		7.0	6.3	5.5	5.1	5.0										
44.0	3.5	3.8	3.9			6.2	6.5	6.9	7.0		7.2	7.7	8.0	7.7		6.7	6.1	5.4	5.0	4.9										
46.0		2.5				5.0	5.6	5.9			6.3	6.8	7.3	7.4		6.5	5.9	5.3	4.9	4.8										
48.0						3.9	4.3	4.8			5.6	6.0	6.5	6.7		6.3	5.7	5.1	4.8											
50.0						2.8	3.2	3.5			4.8	5.2	5.7	5.9		5.9	5.6	5.0	4.7											
54.0											3.0	3.5	4.1			4.6	5.0	4.8	4.6											
58.0												1.8	2.1			3.2	3.9	4.3												
62.0																1.8	2.3	2.9												
θ (°)	33~ 84.5	30~ 84.5	36~ 84.5	48~ 84.5	64~ 84.5	35~ 84.5	37~ 84.5	39~ 84.5	52~ 84.5	65~ 84.5	38~ 84.5	35~ 84.5	37~ 84.5	53~ 84.5	69~ 84.5	35~ 84.5	39~ 84.5	44~ 84.5	59~ 84.5	72~ 84.5										
標準フック	80t																													
フック重量	1550kg										950kg																			
標準巻掛本数	4										2										1									

カウンタウエイト 98t、アウトリガ張出幅 8.5m
45.4mブーム+2.3m+フルオートラフィングジブ

単位:t

ジブ長さ(m) 作業半径 (m)	10.3m オフセット					17.2m オフセット					24.1m オフセット					31.0m オフセット				
	5°	15°	30°	45°	60°	5°	15°	30°	45°	60°	5°	15°	30°	45°	60°	5°	15°	30°	45°	60°
10.0	29.5																			
11.0	27.8																			
12.0	26.3	24.5				16.7														
14.0	23.6	22.2	20.6			16.7					15.3									
16.0	21.4	20.3	19.0	18.0		16.7	16.7				14.8					10.4				
18.0	19.6	18.6	17.5	16.7	16.2	16.7	16.7				14.4					10.3				
20.0	18.0	17.2	16.2	15.6	15.1	16.4	15.4	14.3			14.0	12.8				10.1				
22.0	16.6	15.9	15.1	14.5	14.2	15.2	14.3	13.3			13.7	12.4				9.9	9.0			
24.0	15.4	14.8	14.1	13.6	13.3	14.1	13.3	12.5	11.9		13.0	12.0				9.6	8.7			
26.0	14.3	13.8	13.2	12.8	12.6	13.1	12.4	11.7	11.2	10.8	12.1	11.4	10.4			9.4	8.3			
28.0	13.4	12.9	12.4	12.0	11.9	12.2	11.6	11.0	10.5	10.2	11.3	10.7	9.9			9.2	8.0			
30.0	12.2	12.1	11.6	11.3	11.2	11.4	10.9	10.3	9.9	9.7	10.6	10.0	9.4	8.8		8.8	7.7	6.6		
32.0	10.9	10.9	10.8	10.7		10.7	10.2	9.7	9.4	9.2	9.9	9.4	8.9	8.5	8.2	8.4	7.4	6.4		
34.0	9.8	9.8	9.7	9.7		10.0	9.6	9.2	8.9	8.7	9.3	8.9	8.4	8.1	7.9	8.1	7.2	6.2		
36.0	8.4	8.7	8.8	8.7		9.1	9.1	8.7	8.4	8.3	8.8	8.4	7.9	7.7	7.5	7.8	6.9	6.0	5.5	
38.0	7.2	7.4	7.7	7.8		8.2	8.2	8.0	7.8	7.7	8.2	7.9	7.5	7.2	7.0	7.5	6.7	5.8	5.3	
40.0	6.0	6.3	6.5	6.6		7.4	7.4	7.4	7.3		7.5	7.2	6.9	6.7	6.5	7.2	6.5	5.7	5.2	5.0
42.0	5.0	5.2	5.5			6.4	6.7	6.8	6.7		6.9	6.7	6.4	6.2	6.1	6.9	6.3	5.5	5.1	4.9
44.0	3.6	4.0	4.3			5.5	5.8	6.1	6.1		6.2	6.2	5.9	5.8		6.3	6.1	5.4	5.0	4.8
46.0	2.4	2.7	2.9			4.6	5.0	5.4	5.5		5.6	5.7	5.5	5.3		5.8	5.7	5.2	4.9	4.8
48.0		1.5	1.7			3.7	4.2	4.5	4.6		4.9	5.2	5.1	4.9		5.4	5.2	5.0	4.8	4.7
50.0						2.7	3.2	3.7			4.2	4.6	4.7	4.6		5.0	4.8	4.7	4.5	
54.0								1.5			2.7	3.3	3.7			3.9	4.1	4.0	3.9	
58.0												1.6	2.2			2.8	3.3	3.3	3.3	
62.0																2.1	2.7			
θ(°)	38~ 84.5	36~ 84.5	36~ 84.5	51~ 84.5	66~ 84.5	42~ 84.5	44~ 84.5	39~ 84.5	50~ 84.5	65~ 84.5	44~ 84.5	42~ 84.5	46~ 84.5	60~ 84.5	71~ 84.5	46~ 84.5	46~ 84.5	50~ 84.5	58~ 84.5	72~ 84.5
標準フック	35t					35t					35t					12.2t				
フック重量	950kg					950kg					950kg					440kg				
標準巻掛本数	3					2					1									

カウンタウエイト 98t、アウトリガ張出幅 8.5m
50.5mブーム+2.3m+フルオートラフィングジブ

単位:t

ジブ長さ(m) 作業半径 (m)	10.3m オフセット					17.2m オフセット					24.1m オフセット					31.0m オフセット				
	5°	15°	30°	45°	60°	5°	15°	30°	45°	60°	5°	15°	30°	45°	60°	5°	15°	30°	45°	60°
11.0	21.2																			
12.0	20.0																			
14.0	17.8	16.8				16.5														
16.0	16.0	15.2	14.2			15.0					13.5									
18.0	14.5	13.9	13.1	12.4	11.9	13.6	12.5				12.4					9.1				
20.0	13.2	12.7	12.1	11.6	11.2	12.5	11.7				11.5					9.1				
22.0	12.1	11.6	11.1	10.7	10.5	11.4	10.8	9.8			10.7	9.6				9.1				
24.0	11.1	10.7	10.3	10.0	9.7	10.5	10.0	9.2	8.5		9.9	9.0				9.1	8.3			
26.0	10.2	9.9	9.5	9.2	9.1	9.7	9.3	8.7	8.1	7.7	9.1	8.5	7.5			8.7	7.8			
28.0	9.3	9.0	8.7	8.5	8.3	9.0	8.6	8.2	7.7	7.4	8.5	8.0	7.1			8.2	7.4			
30.0	8.3	8.1	7.8	7.6	7.5	8.2	7.9	7.6	7.4	7.1	7.8	7.5	6.8			7.7	7.0			
32.0	7.4	7.2	7.0	6.9	6.7	7.3	7.1	6.9	6.7	6.6	7.1	6.9	6.4	6.0		7.2	6.6	5.9		
34.0	6.6	6.4	6.3	6.1		6.5	6.4	6.2	6.1	6.0	6.4	6.2	6.1	5.7	5.4	6.6	6.3	5.6		
36.0	5.8	5.7	5.6	5.5		5.9	5.7	5.6	5.5	5.4	5.7	5.6	5.5	5.4	5.2	5.9	5.8	5.3		
38.0	5.1	5.1	4.9	4.9		5.2	5.1	5.0	4.9	4.9	5.1	5.0	5.0	4.9	4.8	5.3	5.3	5.1	4.7	
40.0	4.5	4.5	4.4	4.3		4.6	4.6	4.5	4.4	4.4	4.6	4.5	4.5	4.4	4.4	4.8	4.8	4.7	4.5	
42.0	4.0	3.9	3.8	3.8		4.1	4.1	4.0	4.0		4.1	4.0	4.0	4.0	3.9	4.3	4.3	4.3	4.2	4.0
44.0	3.5	3.4	3.4	3.3		3.6	3.6	3.6	3.5		3.6	3.6	3.6	3.6	3.5	3.9	3.9	3.9	3.9	3.7
46.0	2.6	2.9	2.9			3.2	3.1	3.1	3.1		3.2	3.2	3.2	3.2		3.4	3.5	3.5	3.5	3.5
48.0	1.5	1.8	2.1			2.7	2.7	2.7	2.7		2.8	2.8	2.8	2.8		3.0	3.1	3.1	3.1	3.1
50.0						2.4	2.4	2.4	2.3		2.4	2.4	2.5	2.5		2.7	2.7	2.8	2.8	2.8
54.0								1.7			1.7	1.8	1.8	1.8		2.0	2.1	2.2	2.2	
58.0																1.5	1.6	1.6		
θ(°)	41~ 84.5	43~ 84.5	44~ 84.5	50~ 84.5	66~ 84.5	41~ 84.5	43~ 84.5	46~ 84.5	52~ 84.5	66~ 84.5	48~ 84.5	52~ 84.5	55~ 84.5	57~ 84.5	70~ 84.5	54~ 84.5	54~ 84.5	59~ 84.5	62~ 84.5	73~ 84.5
標準フック	35t					35t					35t					12.2t				
フック重量	950kg					950kg					950kg					440kg				
標準巻掛本数	2					2					1									

フルオートラフィングジブ

カウンタウエイト 98t、アウトリガ張出幅 8.5m
55.6mブーム+2.3m+フルオートラフィングジブ

単位:t

ジブ長さ(m) 作業半径 (m)	10.3m オフセット					17.2m オフセット					24.1m オフセット					31.0m オフセット				
	5°	15°	30°	45°	60°	5°	15°	30°	45°	60°	5°	15°	30°	45°	60°	5°	15°	30°	45°	60°
12.0	14.6																			
14.0	14.6	14.5																		
16.0	13.9	13.2				12.0														
18.0	12.5	12.1	11.2			11.6	10.7				9.4									
20.0	11.3	11.0	10.4	9.9	9.5	10.7	9.8				9.4					6.4				
22.0	10.3	10.0	9.6	9.2	8.9	9.8	9.1	8.3			9.3	8.5				6.4				
24.0	9.3	9.1	8.8	8.6	8.4	8.9	8.5	7.8			8.6	7.9				6.4				
26.0	8.1	8.0	7.8	7.7	7.5	8.0	7.9	7.3	6.9		8.0	7.4				6.4	6.4			
28.0	7.0	6.9	6.8	6.7	6.6	7.0	6.9	6.8	6.5	6.2	7.3	6.9	6.3			6.4	6.4			
30.0	6.1	6.0	6.0	5.9	5.8	6.1	6.1	6.1	6.0	5.9	6.5	6.5	5.9			6.4	6.0			
32.0	5.2	5.2	5.2	5.1	5.0	5.3	5.3	5.3	5.3	5.3	5.7	5.7	5.6			5.8	5.6			
34.0	4.5	4.5	4.4	4.4	4.3	4.6	4.6	4.7	4.7	4.6	5.0	5.1	5.1	4.9		5.1	5.2	4.9		
36.0	3.8	3.8	3.8	3.7	3.7	3.9	4.0	4.1	4.1	4.0	4.4	4.5	4.6	4.5	4.3	4.5	4.6	4.5		
38.0	3.1	3.1	3.2	3.1		3.3	3.4	3.5	3.5	3.5	3.8	3.9	4.0	4.1	4.0	3.9	4.1	4.1		
40.0	2.5	2.6	2.6	2.6		2.8	2.9	3.0	3.0	3.0	3.2	3.4	3.5	3.6	3.6	3.4	3.6	3.7	3.5	
42.0	2.0	2.0	2.1	2.0		2.3	2.4	2.5	2.5	2.5	2.7	2.9	3.0	3.1	3.1	3.0	3.1	3.3	3.2	
44.0	1.5	1.5	1.6	1.6		1.8	1.9	2.0	2.1		2.3	2.4	2.6	2.7	2.7	2.5	2.7	2.9	2.9	2.8
46.0							1.5	1.6	1.6		1.9	2.0	2.2	2.3	2.3	2.1	2.3	2.5	2.6	2.6
48.0											1.5	1.6	1.8	1.9		1.7	1.9	2.1	2.3	2.3
50.0														1.5			1.6	1.8	1.9	2.0
θ (°)	51~ 84.5	53~ 84.5	54~ 84.5	55~ 84.5	64~ 84.5	57~ 84.5	57~ 84.5	60~ 84.5	61~ 84.5	66~ 84.5	58~ 84.5	61~ 84.5	65~ 84.5	66~ 84.5	71~ 84.5	63~ 84.5	64~ 84.5	69~ 84.5	73~ 84.5	75~ 84.5
標準フック											12.2t									
フック重量	950kg										440kg									
標準巻掛本数	2										1									

カウンタウエイト 98t、アウトリガ張出幅 8.5m
60.0mブーム+2.3m+フルオートラフィングジブ

単位:t

ジブ長さ(m) 作業半径 (m)	10.3m オフセット					17.2m オフセット					24.1m オフセット					31.0m オフセット				
	5°	15°	30°	45°	60°	5°	15°	30°	45°	60°	5°	15°	30°	45°	60°	5°	15°	30°	45°	60°
14.0	12.0																			
16.0	12.0	11.6				8.0														
18.0	11.0	10.6	9.9			8.0					7.1									
20.0	9.9	9.6	9.2	8.8		8.0	8.0				7.1					5.7				
22.0	8.9	8.7	8.5	8.1	7.9	8.0	8.0				7.1					5.7				
24.0	7.7	7.7	7.6	7.5	7.3	8.0	7.7	7.2			7.1	6.9				5.7				
26.0	6.7	6.6	6.6	6.5	6.4	7.1	7.1	6.7			7.1	6.6				5.7				
28.0	5.7	5.7	5.7	5.6	5.5	6.1	6.2	6.2	5.9		6.3	6.2				5.7				
30.0	4.8	4.8	4.8	4.8	4.7	5.3	5.4	5.4	5.4	5.4	5.5	5.6	5.3			5.6	5.2			
32.0	4.0	4.1	4.1	4.1	4.0	4.5	4.6	4.7	4.8	4.7	4.7	4.9	4.9			4.9	4.9			
34.0	3.3	3.4	3.4	3.4	3.3	3.9	4.0	4.1	4.1	4.1	4.1	4.2	4.4	4.2		4.3	4.4			
36.0	2.7	2.7	2.8	2.8	2.7	3.2	3.3	3.5	3.5	3.5	3.5	3.6	3.8	3.9		3.7	3.9	3.6		
38.0	2.1	2.1	2.2	2.2		2.6	2.8	2.9	3.0	3.0	2.9	3.1	3.3	3.4	3.4	3.2	3.4	3.3		
40.0	1.5	1.6	1.7	1.7		2.1	2.3	2.4	2.5	2.5	2.4	2.6	2.8	3.0	3.0	2.7	2.9	3.0		
42.0						1.6	1.8	1.9	2.0	2.0	1.9	2.1	2.4	2.5	2.5	2.2	2.5	2.7	2.6	
44.0								1.5	1.6		1.5	1.7	2.0	2.1	2.1	1.8	2.0	2.3	2.4	
46.0													1.6	1.7	1.7		1.7	2.0	2.1	2.2
48.0																	1.6	1.8	1.8	1.8
50.0																				1.5
θ (°)	59~ 84.5	60~ 84.5	62~ 84.5	63~ 84.5	67~ 84.5	62~ 84.5	64~ 84.5	65~ 84.5	66~ 84.5	69~ 84.5	64~ 84.5	66~ 84.5	69~ 84.5	72~ 84.5	73~ 84.5	68~ 84.5	69~ 84.5	72~ 84.5	76~ 84.5	77~ 84.5
標準フック											12.2t									
フック重量											440kg									
標準巻掛本数											1									

カウンタウエイト 98t、アウトリガ張出幅 8.0m
40.4mブーム+2.3m+フルオートラフィングジブ

単位:t

ジブ長さ(m) 作業半径 (m)	10.3m オフセット					17.2m オフセット					24.1m オフセット					31.0m オフセット				
	5°	15°	30°	45°	60°	5°	15°	30°	45°	60°	5°	15°	30°	45°	60°	5°	15°	30°	45°	60°
9.0	38.4																			
10.0	36.0					16.7														
11.0	33.8	31.6				16.7														
12.0	31.9	30.2				16.7														
14.0	28.6	27.3	25.2			16.7	16.7				16.0									
16.0	25.8	24.8	23.5	22.1	21.1	16.7	16.7				15.5					10.9				
18.0	23.5	22.6	21.6	20.9	20.3	16.7	16.7	16.7			15.0	13.5				10.8				
20.0	21.5	20.8	19.9	19.4	19.0	16.7	16.7	15.9			14.5	13.0				10.5				
22.0	19.8	19.2	18.5	18.0	17.7	16.7	16.7	15.2	14.0		13.9	12.5				10.3	9.2			
24.0	18.3	17.8	17.2	16.8	16.6	16.7	16.2	14.5	13.4	12.9	13.4	12.1	10.8			10.0	8.8			
26.0	17.0	16.5	16.0	15.7	15.5	15.9	15.4	13.9	13.0	12.5	12.9	11.7	10.5			9.7	8.4			
28.0	15.8	15.4	15.0	14.7	14.6	14.8	14.4	13.3	12.5	12.1	12.5	11.4	10.1	9.3		9.2	8.1			
30.0	13.9	14.2	14.0	13.8		13.9	13.5	12.8	12.1	11.8	12.1	11.1	9.8	9.0	8.5	8.8	7.8	6.7		
32.0	12.1	12.4	12.7	12.9		13.0	12.6	12.2	11.8	11.6	11.7	10.8	9.6	8.8	8.4	8.5	7.5	6.5		
34.0	10.5	10.8	11.1	11.2		11.9	11.9	11.5	11.3	11.2	11.3	10.4	9.3	8.6	8.3	8.1	7.2	6.2		
36.0	9.1	9.4	9.6	9.7		10.5	11.0	10.9	10.7	10.6	10.9	10.0	9.0	8.5	8.2	7.8	6.9	6.1	5.5	
38.0	7.2	7.7	8.2	8.3		9.3	9.7	10.1	10.1		10.2	9.6	8.8	8.3	8.1	7.5	6.7	5.9	5.3	
40.0	5.6	6.0	6.3			8.2	8.5	9.0	9.2		9.1	9.3	8.5	8.1	8.0	7.2	6.5	5.7	5.2	5.0
42.0	4.1	4.4	4.7			6.9	7.5	7.9	8.1		8.1	8.5	8.2	7.9		7.0	6.3	5.5	5.1	5.0
44.0	2.8	3.1	3.2			5.5	6.2	6.9	7.0		7.2	7.7	8.0	7.7		6.7	6.1	5.4	5.0	4.9
46.0						4.3	4.9	5.5			6.3	6.8	7.3	7.4		6.5	5.9	5.3	4.9	4.8
48.0						3.2	3.7	4.1			5.2	6.0	6.5	6.7		6.3	5.7	5.1	4.8	
50.0						2.2	2.6	2.9			4.2	4.9	5.7	5.9		5.9	5.6	5.0	4.7	
54.0											2.4	2.9	3.6			4.2	5.0	4.8	4.6	
58.0													1.5			2.6	3.3	4.2		
62.0																1.8	2.4			
θ(°)	33~ 84.5	35~ 84.5	36~ 84.5	48~ 84.5	64~ 84.5	35~ 84.5	37~ 84.5	39~ 84.5	52~ 84.5	65~ 84.5	38~ 84.5	42~ 84.5	37~ 84.5	53~ 84.5	69~ 84.5	41~ 84.5	39~ 84.5	44~ 84.5	59~ 84.5	72~ 84.5
標準フック	80t					35t					12.2t									
フック重量	1550kg					950kg					440kg									
標準巻掛本数	4					2					1									

カウンタウエイト 98t、アウトリガ張出幅 8.0m
45.4mブーム+2.3m+フルオートラフィングジブ

単位:t

ジブ長さ(m) 作業半径 (m)	10.3m オフセット					17.2m オフセット					24.1m オフセット					31.0m オフセット				
	5°	15°	30°	45°	60°	5°	15°	30°	45°	60°	5°	15°	30°	45°	60°	5°	15°	30°	45°	60°
10.0	29.5																			
11.0	27.8																			
12.0	26.3	24.5				16.7														
14.0	23.6	22.2	20.6			16.7					15.3									
16.0	21.4	20.3	19.0	18.0		16.7	16.7				14.8					10.4				
18.0	19.6	18.6	17.5	16.7	16.2	16.7	16.7				14.4					10.3				
20.0	18.0	17.2	16.2	15.6	15.1	16.4	15.4	14.3			14.0	12.8				10.1				
22.0	16.6	15.9	15.1	14.5	14.2	15.2	14.3	13.3			13.7	12.4				9.9	9.0			
24.0	15.4	14.8	14.1	13.6	13.3	14.1	13.3	12.5	11.9		13.0	12.0				9.6	8.7			
26.0	14.3	13.8	13.2	12.8	12.6	13.1	12.4	11.7	11.2	10.8	12.1	11.4	10.4			9.4	8.3			
28.0	13.4	12.9	12.4	12.0	11.9	12.2	11.6	11.0	10.5	10.2	11.3	10.7	9.9			9.2	8.0			
30.0	12.2	12.1	11.6	11.3	11.2	11.4	10.9	10.3	9.9	9.7	10.6	10.0	9.4	8.8		8.8	7.7	6.6		
32.0	10.9	10.9	10.8	10.7		10.7	10.2	9.7	9.4	9.2	9.9	9.4	8.9	8.5	8.2	8.4	7.4	6.4		
34.0	9.8	9.8	9.7	9.7		10.0	9.6	9.2	8.9	8.7	9.3	8.9	8.4	8.1	7.9	8.1	7.2	6.2		
36.0	8.4	8.7	8.8	8.7		9.1	9.1	8.7	8.4	8.3	8.8	8.4	7.9	7.7	7.5	7.8	6.9	6.0	5.5	
38.0	7.2	7.4	7.7	7.8		8.2	8.2	8.0	7.8	7.7	8.2	7.9	7.5	7.2	7.0	7.5	6.7	5.8	5.3	
40.0	5.7	6.2	6.5	6.6		7.4	7.4	7.4	7.3		7.5	7.2	6.9	6.7	6.5	7.2	6.5	5.7	5.2	5.0
42.0	4.2	4.6	5.0			6.4	6.7	6.8	6.7		6.9	6.7	6.4	6.2	6.1	6.9	6.3	5.5	5.1	4.9
44.0	2.9	3.2	3.5			5.4	5.8	6.1	6.1		6.2	6.2	5.9	5.8		6.3	6.1	5.4	5.0	4.8
46.0	1.7	2.0	2.2			4.2	4.8	5.4	5.5		5.6	5.7	5.5	5.3		5.8	5.7	5.2	4.9	4.8
48.0						3.0	3.6	4.3	4.5		4.9	5.2	5.1	4.9		5.4	5.2	5.0	4.8	4.7
50.0						2.0	2.5	3.1			3.9	4.6	4.7	4.6		5.0	4.8	4.7	4.5	
54.0											2.1	2.8	3.6			3.9	4.1	4.0	3.9	
58.0													1.7			2.3	3.1	3.3	3.3	
62.0																1.6	2.4			
θ(°)	38~ 84.5	39~ 84.5	40~ 84.5	51~ 84.5	66~ 84.5	42~ 84.5	44~ 84.5	46~ 84.5	50~ 84.5	65~ 84.5	44~ 84.5	48~ 84.5	46~ 84.5	60~ 84.5	71~ 84.5	46~ 84.5	46~ 84.5	50~ 84.5	58~ 84.5	72~ 84.5
標準フック	35t					35t					12.2t									
フック重量	950kg					950kg					440kg									
標準巻掛本数	3					2					1									

フルオートラフィングジブ

カウンタウエイト 98t、アウトリガ張出幅 8.0m
50.5mブーム+2.3m+フルオートラフィングジブ

単位:t

ジブ長さ(m) 作業半径 (m)	10.3m オフセット					17.2m オフセット					24.1m オフセット					31.0m オフセット									
	5°	15°	30°	45°	60°	5°	15°	30°	45°	60°	5°	15°	30°	45°	60°	5°	15°	30°	45°	60°					
11.0	21.2																								
12.0	20.0																								
14.0	17.8	16.8				16.5																			
16.0	16.0	15.2	14.2			15.0					13.5														
18.0	14.5	13.9	13.1	12.4	11.9	13.6	12.5				12.4					9.1									
20.0	13.2	12.7	12.1	11.6	11.2	12.5	11.7				11.5					9.1									
22.0	12.1	11.6	11.1	10.7	10.5	11.4	10.8	9.8			10.7	9.6				9.1									
24.0	11.1	10.7	10.3	10.0	9.7	10.5	10.0	9.2	8.5		9.9	9.0				9.1	8.3								
26.0	10.2	9.9	9.5	9.2	9.1	9.7	9.3	8.7	8.1	7.7	9.1	8.5	7.5			8.7	7.8								
28.0	9.3	9.0	8.7	8.5	8.3	9.0	8.6	8.2	7.7	7.4	8.5	8.0	7.1			8.2	7.4								
30.0	8.3	8.1	7.8	7.6	7.5	8.2	7.9	7.6	7.4	7.1	7.8	7.5	6.8			7.7	7.0								
32.0	7.4	7.2	7.0	6.9	6.7	7.3	7.1	6.9	6.7	6.6	7.1	6.9	6.4	6.0		7.2	6.6	5.9							
34.0	6.6	6.4	6.3	6.1		6.5	6.4	6.2	6.1	6.0	6.4	6.2	6.1	5.7	5.4	6.6	6.3	5.6							
36.0	5.8	5.7	5.6	5.5		5.9	5.7	5.6	5.5	5.4	5.7	5.6	5.5	5.4	5.2	5.9	5.8	5.3							
38.0	5.1	5.1	4.9	4.9		5.2	5.1	5.0	4.9	4.9	5.1	5.0	5.0	4.9	4.8	5.3	5.3	5.1	4.7						
40.0	4.5	4.5	4.4	4.3		4.6	4.6	4.5	4.4	4.4	4.6	4.5	4.5	4.4	4.4	4.8	4.8	4.7	4.5						
42.0	4.0	3.9	3.8	3.8		4.1	4.1	4.0	4.0		4.1	4.0	4.0	4.0	3.9	4.3	4.3	4.3	4.2	4.0					
44.0	3.1	3.4	3.4	3.3		3.6	3.6	3.6	3.5		3.6	3.6	3.6	3.6	3.5	3.9	3.9	3.9	3.9	3.7					
46.0	1.9	2.2	2.6			3.2	3.1	3.1	3.1		3.2	3.2	3.2	3.2		3.4	3.5	3.5	3.5	3.5					
48.0						2.7	2.7	2.7	2.7		2.8	2.8	2.8	2.8		3.0	3.1	3.1	3.1	3.1					
50.0						2.1	2.4	2.4	2.3		2.4	2.4	2.5	2.5		2.7	2.7	2.8	2.8	2.8					
54.0											1.7	1.8	1.8	1.8		2.0	2.1	2.2	2.2						
58.0																1.5	1.6	1.6							
θ(°)	44~	46~	47~	50~	66~	46~	49~	51~	52~	66~	48~	52~	55~	57~	70~	54~	54~	59~	62~	73~					
	84.5	84.5	84.5	84.5	84.5	84.5	84.5	84.5	84.5	84.5	84.5	84.5	84.5	84.5	84.5	84.5	84.5	84.5	84.5	84.5					
標準フック																35t					12.2t				
フック重量																950kg					440kg				
標準巻掛本数																2					1				

カウンタウエイト 98t、アウトリガ張出幅 8.0m
55.6mブーム+2.3m+フルオートラフィングジブ

単位:t

ジブ長さ(m) 作業半径 (m)	10.3m オフセット					17.2m オフセット					24.1m オフセット					31.0m オフセット									
	5°	15°	30°	45°	60°	5°	15°	30°	45°	60°	5°	15°	30°	45°	60°	5°	15°	30°	45°	60°					
12.0	14.6																								
14.0	14.6	14.5																							
16.0	13.9	13.2				12.0																			
18.0	12.5	12.1	11.2			11.6	10.7				9.4														
20.0	11.3	11.0	10.4	9.9	9.5	10.7	9.8				9.4					6.4									
22.0	10.3	10.0	9.6	9.2	8.9	9.8	9.1	8.3			9.3	8.5				6.4									
24.0	9.3	9.1	8.8	8.6	8.4	8.9	8.5	7.8			8.6	7.9				6.4									
26.0	8.1	8.0	7.8	7.7	7.5	8.0	7.9	7.3	6.9		8.0	7.4				6.4	6.4								
28.0	7.0	6.9	6.8	6.7	6.6	7.0	6.9	6.8	6.5	6.2	7.3	6.9	6.3			6.4	6.4								
30.0	6.1	6.0	6.0	5.9	5.8	6.1	6.1	6.1	6.0	5.9	6.5	6.5	5.9			6.4	6.0								
32.0	5.2	5.2	5.2	5.1	5.0	5.3	5.3	5.3	5.3	5.3	5.7	5.7	5.6			5.8	5.6								
34.0	4.5	4.5	4.4	4.4	4.3	4.6	4.6	4.7	4.7	4.6	5.0	5.1	5.1	4.9		5.1	5.2	4.9							
36.0	3.8	3.8	3.8	3.7	3.7	3.9	4.0	4.1	4.1	4.0	4.4	4.5	4.6	4.5	4.3	4.5	4.6	4.5							
38.0	3.1	3.1	3.2	3.1		3.3	3.4	3.5	3.5	3.5	3.8	3.9	4.0	4.1	4.0	3.9	4.1	4.1							
40.0	2.5	2.6	2.6	2.6		2.8	2.9	3.0	3.0	3.0	3.2	3.4	3.5	3.6	3.6	3.4	3.6	3.7	3.5						
42.0	2.0	2.0	2.1	2.0		2.3	2.4	2.5	2.5	2.5	2.7	2.9	3.0	3.1	3.1	3.0	3.1	3.3	3.2						
44.0	1.5	1.5	1.6	1.6		1.8	1.9	2.0	2.1		2.3	2.4	2.6	2.7	2.7	2.5	2.7	2.9	2.9	2.8					
46.0							1.5	1.6	1.6		1.9	2.0	2.2	2.3	2.3	2.1	2.3	2.5	2.6	2.6					
48.0											1.5	1.6	1.8	1.9		1.7	1.9	2.1	2.3	2.3					
50.0														1.5		1.6	1.8	1.9	2.0						
θ(°)	51~	53~	54~	55~	64~	57~	57~	60~	61~	66~	58~	61~	65~	66~	71~	63~	64~	69~	73~	75~					
	84.5	84.5	84.5	84.5	84.5	84.5	84.5	84.5	84.5	84.5	84.5	84.5	84.5	84.5	84.5	84.5	84.5	84.5	84.5	84.5					
標準フック																35t					12.2t				
フック重量																950kg					440kg				
標準巻掛本数																2					1				

カウンタウエイト 98t、アウトリガ張出幅 8.0m
60.0mブーム+2.3m+フルオートラフィングジブ

単位:t

ジブ長さ(m) 作業半径 (m)	10.3m オフセット					17.2m オフセット					24.1m オフセット					31.0m オフセット				
	5°	15°	30°	45°	60°	5°	15°	30°	45°	60°	5°	15°	30°	45°	60°	5°	15°	30°	45°	60°
14.0	12.0					8.0														
16.0	12.0	11.6				8.0														
18.0	11.0	10.6	9.9									7.1								
20.0	9.9	9.6	9.2	8.8		8.0	8.0					7.1					5.7			
22.0	8.9	8.7	8.5	8.1	7.9	8.0	8.0					7.1					5.7			
24.0	7.7	7.7	7.6	7.5	7.3	8.0	7.7	7.2				7.1	6.9				5.7			
26.0	6.7	6.6	6.6	6.5	6.4	7.1	7.1	6.7				7.1	6.6				5.7			
28.0	5.7	5.7	5.7	5.6	5.5	6.1	6.2	6.2	5.9			6.3	6.2				5.7			
30.0	4.8	4.8	4.8	4.8	4.7	5.3	5.4	5.4	5.4	5.4	5.5	5.6	5.3			5.6	5.2			
32.0	4.0	4.1	4.1	4.1	4.0	4.5	4.6	4.7	4.8	4.7	4.7	4.9	4.9			4.9	4.9			
34.0	3.3	3.4	3.4	3.4	3.3	3.9	4.0	4.1	4.1	4.1	4.1	4.2	4.4	4.2		4.3	4.4			
36.0	2.7	2.7	2.8	2.8	2.7	3.2	3.3	3.5	3.5	3.5	3.5	3.6	3.8	3.9		3.7	3.9	3.6		
38.0	2.1	2.1	2.2	2.2		2.6	2.8	2.9	3.0	3.0	2.9	3.1	3.3	3.4	3.4	3.2	3.4	3.3		
40.0	1.5	1.6	1.7	1.7		2.1	2.3	2.4	2.5	2.5	2.4	2.6	2.8	3.0	3.0	2.7	2.9	3.0		
42.0						1.6	1.8	1.9	2.0	2.0	1.9	2.1	2.4	2.5	2.5	2.2	2.5	2.7	2.6	
44.0								1.5	1.6			1.5	1.7	2.0	2.1	1.8	2.0	2.3	2.4	
46.0													1.6	1.7	1.7		1.7	2.0	2.1	2.2
48.0																	1.6	1.8	1.8	
50.0																			1.5	
θ(°)	59~ 84.5	60~ 84.5	62~ 84.5	63~ 84.5	67~ 84.5	62~ 84.5	64~ 84.5	65~ 84.5	66~ 84.5	69~ 84.5	64~ 84.5	66~ 84.5	69~ 84.5	72~ 84.5	73~ 84.5	68~ 84.5	69~ 84.5	72~ 84.5	76~ 84.5	77~ 84.5
標準フック	12.2t																			
フック重量	440kg																			
標準巻掛本数	1																			

カウンタウエイト 78t、アウトリガ張出幅 8.5m
40.4mブーム+2.3m+フルオートラフィングジブ

単位:t

ジブ長さ(m) 作業半径 (m)	10.3m オフセット					17.2m オフセット					24.1m オフセット					31.0m オフセット				
	5°	15°	30°	45°	60°	5°	15°	30°	45°	60°	5°	15°	30°	45°	60°	5°	15°	30°	45°	60°
9.0	38.4																			
10.0	36.0					16.7														
11.0	33.8	31.6				16.7														
12.0	31.9	30.2				16.7														
14.0	28.6	27.3	25.2			16.7	16.7					16.0								
16.0	25.8	24.8	23.5	22.1	21.1	16.7	16.7					15.5					10.9			
18.0	23.5	22.6	21.6	20.9	20.3	16.7	16.7	16.7				15.0	13.5				10.8			
20.0	21.5	20.8	19.9	19.4	19.0	16.7	16.7	15.9				14.5	13.0				10.5			
22.0	19.8	19.2	18.5	18.0	17.7	16.7	16.7	15.2	14.0			13.9	12.5				10.3	9.2		
24.0	18.3	17.8	17.2	16.8	16.6	16.7	16.2	14.5	13.4	12.9		13.4	12.1	10.8			10.0	8.8		
26.0	17.0	16.5	16.0	15.7	15.5	15.9	15.4	13.9	13.0	12.5	12.9	11.7	10.5				9.7	8.4		
28.0	14.8	15.4	15.0	14.7	14.6	14.8	14.4	13.3	12.5	12.1	12.5	11.4	10.1	9.3			9.2	8.1		
30.0	12.0	12.8	13.8	13.8		13.9	13.5	12.8	12.1	11.8	12.1	11.1	9.8	9.0	8.5		8.8	7.8	6.7	
32.0	9.5	10.3	11.1	11.5		12.5	12.6	12.2	11.8	11.6	11.7	10.8	9.6	8.8	8.4	8.5	7.5	6.5		
34.0	7.4	8.1	8.8	9.1		10.4	11.5	11.5	11.3	11.2	11.3	10.4	9.3	8.6	8.3	8.1	7.2	6.2		
36.0	5.6	6.1	6.7	6.9		8.5	9.5	10.8	10.7	10.6	10.6	10.0	9.0	8.5	8.2	7.8	6.9	6.1	5.5	
38.0	4.0	4.4	4.9	5.0		6.8	7.7	8.9	9.6		8.9	9.6	8.8	8.3	8.1	7.5	6.7	5.9	5.3	
40.0	2.5	2.9	3.3			5.3	6.2	7.2	7.7		7.4	8.6	8.5	8.1	8.0	7.2	6.5	5.7	5.2	5.0
42.0						4.0	4.7	5.6	6.0		6.1	7.2	8.2	7.9		7.0	6.3	5.5	5.1	5.0
44.0						2.8	3.4	4.2	4.4		4.8	5.9	7.2	7.7		6.7	6.1	5.4	5.0	4.9
46.0						1.7	2.3	2.9			3.7	4.7	5.8	6.6		5.6	5.9	5.3	4.9	4.8
48.0								1.6			2.7	3.6	4.6	5.2		4.6	5.7	5.1	4.8	
50.0											1.8	2.6	3.4	3.9		3.7	4.7	5.0	4.7	
54.0																2.0	2.9	4.0	4.6	
58.0																			2.2	
θ(°)	41~ 84.5	43~ 84.5	44~ 84.5	48~ 84.5	64~ 84.5	42~ 84.5	44~ 84.5	44~ 84.5	52~ 84.5	65~ 84.5	44~ 84.5	48~ 84.5	51~ 84.5	53~ 84.5	69~ 84.5	46~ 84.5	50~ 84.5	50~ 84.5	59~ 84.5	72~ 84.5
標準フック	80t					35t					12.2t									
フック重量	1550kg					950kg					440kg									
標準巻掛本数	4					2					1									

フルオートラフィングジブ

カウンタウエイト 78t、アウトリガ張出幅 8.5m
45.4mブーム+2.3m+フルオートラフィングジブ

単位:t

ジブ長さ(m) 作業半径 (m)	10.3m オフセット					17.2m オフセット					24.1m オフセット					31.0m オフセット				
	5°	15°	30°	45°	60°	5°	15°	30°	45°	60°	5°	15°	30°	45°	60°	5°	15°	30°	45°	60°
10.0	29.5																			
11.0	27.8																			
12.0	26.3	24.5				16.7														
14.0	23.6	22.2	20.6			16.7					15.3									
16.0	21.4	20.3	19.0	18.0		16.7	16.7				14.8					10.4				
18.0	19.6	18.6	17.5	16.7	16.2	16.7	16.7				14.4					10.3				
20.0	18.0	17.2	16.2	15.6	15.1	16.4	15.4	14.3			14.0	12.8				10.1				
22.0	16.6	15.9	15.1	14.5	14.2	15.2	14.3	13.3			13.7	12.4				9.9	9.0			
24.0	15.4	14.8	14.1	13.6	13.3	14.1	13.3	12.5	11.9		13.0	12.0				9.6	8.7			
26.0	14.3	13.8	13.2	12.8	12.6	13.1	12.4	11.7	11.2	10.8	12.1	11.4	10.4			9.4	8.3			
28.0	13.4	12.9	12.4	12.0	11.9	12.2	11.6	11.0	10.5	10.2	11.3	10.7	9.9			9.2	8.0			
30.0	12.1	12.1	11.6	11.3	11.2	11.4	10.9	10.3	9.9	9.7	10.6	10.0	9.4	8.8		8.8	7.7	6.6		
32.0	9.7	10.4	10.8	10.7		10.7	10.2	9.7	9.4	9.2	9.9	9.4	8.9	8.5	8.2	8.4	7.4	6.4		
34.0	7.6	8.2	9.0	9.5		10.0	9.6	9.2	8.9	8.7	9.3	8.9	8.4	8.1	7.9	8.1	7.2	6.2		
36.0	5.7	6.3	7.0	7.3		8.3	9.1	8.7	8.4	8.3	8.8	8.4	7.9	7.7	7.5	7.8	6.9	6.0	5.5	
38.0	4.1	4.6	5.2	5.4		6.7	7.7	8.0	7.8	7.7	8.2	7.9	7.5	7.2	7.0	7.5	6.7	5.8	5.3	
40.0	2.6	3.1	3.6	3.7		5.2	6.1	7.2	7.3		7.1	7.2	6.9	6.7	6.5	7.2	6.5	5.7	5.2	5.0
42.0		1.7	2.1			3.8	4.7	5.6	6.2		5.8	6.7	6.4	6.2	6.1	6.9	6.3	5.5	5.1	4.9
44.0						2.6	3.4	4.2	4.7		4.6	5.7	5.9	5.8		6.3	6.1	5.4	5.0	4.8
46.0							2.2	3.0	3.3		3.5	4.5	5.5	5.3		5.3	5.7	5.2	4.9	4.8
48.0								1.8			2.4	3.4	4.5	4.9		4.3	5.2	5.0	4.8	4.7
50.0												2.4	3.4	4.0		3.3	4.5	4.7	4.5	
54.0																2.6	3.9	3.9		
58.0																	2.1	2.7		
θ (°)	48~ 84.5	46~ 84.5	47~ 84.5	51~ 84.5	66~ 84.5	50~ 84.5	50~ 84.5	50~ 84.5	53~ 84.5	65~ 84.5	51~ 84.5	53~ 84.5	57~ 84.5	60~ 84.5	71~ 84.5	54~ 84.5	55~ 84.5	55~ 84.5	58~ 84.5	72~ 84.5
標準フック																12.2t				
フック重量																440kg				
標準巻掛本数	3															1				

カウンタウエイト 78t、アウトリガ張出幅 8.5m
50.5mブーム+2.3m+フルオートラフィングジブ

単位:t

ジブ長さ(m) 作業半径 (m)	10.3m オフセット					17.2m オフセット					24.1m オフセット					31.0m オフセット				
	5°	15°	30°	45°	60°	5°	15°	30°	45°	60°	5°	15°	30°	45°	60°	5°	15°	30°	45°	60°
11.0	21.2																			
12.0	20.0																			
14.0	17.8	16.8				16.5														
16.0	16.0	15.2	14.2			15.0					13.5									
18.0	14.5	13.9	13.1	12.4	11.9	13.6	12.5				12.4					9.1				
20.0	13.2	12.7	12.1	11.6	11.2	12.5	11.7				11.5					9.1				
22.0	12.1	11.6	11.1	10.7	10.5	11.4	10.8	9.8			10.7	9.6				9.1				
24.0	11.1	10.7	10.3	10.0	9.7	10.5	10.0	9.2	8.5		9.9	9.0				9.1	8.3			
26.0	10.2	9.9	9.5	9.2	9.1	9.7	9.3	8.7	8.1	7.7	9.1	8.5	7.5			8.7	7.8			
28.0	9.3	9.0	8.7	8.5	8.3	9.0	8.6	8.2	7.7	7.4	8.5	8.0	7.1			8.2	7.4			
30.0	8.3	8.1	7.8	7.6	7.5	8.2	7.9	7.6	7.4	7.1	7.8	7.5	6.8			7.7	7.0			
32.0	7.4	7.2	7.0	6.9	6.7	7.3	7.1	6.9	6.7	6.6	7.1	6.9	6.4	6.0		7.2	6.6	5.9		
34.0	6.6	6.4	6.3	6.1		6.5	6.4	6.2	6.1	6.0	6.4	6.2	6.1	5.7	5.4	6.6	6.3	5.6		
36.0	5.8	5.7	5.6	5.5		5.9	5.7	5.6	5.5	5.4	5.7	5.6	5.5	5.4	5.2	5.9	5.8	5.3		
38.0	4.2	4.8	4.9	4.9		5.2	5.1	5.0	4.9	4.9	5.1	5.0	5.0	4.9	4.8	5.3	5.3	5.1	4.7	
40.0	2.8	3.3	3.9	4.1		4.6	4.6	4.5	4.4	4.4	4.6	4.5	4.5	4.4	4.4	4.8	4.8	4.7	4.5	
42.0			2.4	2.6		3.9	4.1	4.0	4.0		4.1	4.0	4.0	4.0	3.9	4.3	4.3	4.3	4.2	4.0
44.0						2.7	3.5	3.6	3.5		3.6	3.6	3.6	3.6	3.5	3.9	3.9	3.9	3.9	3.7
46.0								3.1	3.1		3.2	3.2	3.2	3.2		3.4	3.5	3.5	3.5	3.5
48.0									2.4			2.8	2.8	2.8		3.0	3.1	3.1	3.1	3.1
50.0													2.5	2.5		2.7	2.7	2.8	2.8	2.8
54.0																	2.1	2.2	2.2	
58.0																		1.6		
θ (°)	52~ 84.5	54~ 84.5	53~ 84.5	54~ 84.5	66~ 84.5	53~ 84.5	56~ 84.5	56~ 84.5	55~ 84.5	66~ 84.5	56~ 84.5	58~ 84.5	60~ 84.5	62~ 84.5	70~ 84.5	57~ 84.5	58~ 84.5	63~ 84.5	62~ 84.5	73~ 84.5
標準フック																12.2t				
フック重量																440kg				
標準巻掛本数																1				

カウンタウエイト 78t、アウトリガ張出幅 8.5m
55.6mブーム+2.3m+フルオートラフィングジブ

単位:t

ジブ長さ(m) 作業半径 (m)	10.3m オフセット					17.2m オフセット					24.1m オフセット					31.0m オフセット				
	5°	15°	30°	45°	60°	5°	15°	30°	45°	60°	5°	15°	30°	45°	60°	5°	15°	30°	45°	60°
12.0	14.6																			
14.0	14.6	14.5																		
16.0	13.9	13.2				12.0														
18.0	12.5	12.1	11.2			11.6	10.7				9.4									
20.0	11.3	11.0	10.4	9.9	9.5	10.7	9.8				9.4					6.4				
22.0	10.3	10.0	9.6	9.2	8.9	9.8	9.1	8.3			9.3	8.5				6.4				
24.0	9.3	9.1	8.8	8.6	8.4	8.9	8.5	7.8			8.6	7.9				6.4				
26.0	8.1	8.0	7.8	7.7	7.5	8.0	7.9	7.3	6.9		8.0	7.4				6.4	6.4			
28.0	7.0	6.9	6.8	6.7	6.6	7.0	6.9	6.8	6.5	6.2	7.3	6.9	6.3			6.4	6.4			
30.0	6.1	6.0	6.0	5.9	5.8	6.1	6.1	6.1	6.0	5.9	6.5	6.5	5.9			6.4	6.0			
32.0	5.2	5.2	5.2	5.1	5.0	5.3	5.3	5.3	5.3	5.3	5.7	5.7	5.6			5.8	5.6			
34.0	4.5	4.5	4.4	4.4	4.3	4.6	4.6	4.7	4.7	4.6	5.0	5.1	5.1	4.9		5.1	5.2	4.9		
36.0	3.8	3.8	3.8	3.7	3.7	3.9	4.0	4.1	4.1	4.0	4.4	4.5	4.6	4.5	4.3	4.5	4.6	4.5		
38.0	3.1	3.1	3.2	3.1		3.3	3.4	3.5	3.5	3.5	3.8	3.9	4.0	4.1	4.0	3.9	4.1	4.1		
40.0	2.5	2.6	2.6	2.6		2.8	2.9	3.0	3.0	3.0	3.2	3.4	3.5	3.6	3.6	3.4	3.6	3.7	3.5	
42.0				2.0		2.3	2.4	2.5	2.5	2.5	2.7	2.9	3.0	3.1	3.1	3.0	3.1	3.3	3.2	
44.0							1.9	2.0	2.1		2.3	2.4	2.6	2.7	2.7	2.5	2.7	2.9	2.9	2.8
46.0								1.6	1.6		1.9	2.0	2.2	2.3	2.3	2.1	2.3	2.5	2.6	2.6
48.0												1.6	1.8	1.9		1.7	1.9	2.1	2.3	2.3
50.0														1.5		1.6	1.8	1.9	2.0	
θ(°)	56~ 84.5	57~ 84.5	59~ 84.5	57~ 84.5	64~ 84.5	58~ 84.5	59~ 84.5	60~ 84.5	61~ 84.5	66~ 84.5	60~ 84.5	61~ 84.5	65~ 84.5	66~ 84.5	71~ 84.5	63~ 84.5	64~ 84.5	69~ 84.5	73~ 84.5	75~ 84.5
標準フック											12.2t									
フック重量	950kg										440kg									
標準巻掛本数	2										1									

カウンタウエイト 78t、アウトリガ張出幅 8.5m
60.0mブーム+2.3m+フルオートラフィングジブ

単位:t

ジブ長さ(m) 作業半径 (m)	10.3m オフセット					17.2m オフセット					24.1m オフセット					31.0m オフセット				
	5°	15°	30°	45°	60°	5°	15°	30°	45°	60°	5°	15°	30°	45°	60°	5°	15°	30°	45°	60°
14.0	12.0																			
16.0	12.0	11.6				8.0														
18.0	11.0	10.6	9.9			8.0					7.1									
20.0	9.9	9.6	9.2	8.8		8.0	8.0				7.1					5.7				
22.0	8.9	8.7	8.5	8.1	7.9	8.0	8.0				7.1					5.7				
24.0	7.7	7.7	7.6	7.5	7.3	8.0	7.7	7.2			7.1	6.9				5.7				
26.0	6.7	6.6	6.6	6.5	6.4	7.1	7.1	6.7			7.1	6.6				5.7				
28.0	5.7	5.7	5.7	5.6	5.5	6.1	6.2	6.2	5.9		6.3	6.2				5.7				
30.0	4.8	4.8	4.8	4.8	4.7	5.3	5.4	5.4	5.4	5.4	5.5	5.6	5.3			5.6	5.2			
32.0	4.0	4.1	4.1	4.1	4.0	4.5	4.6	4.7	4.8	4.7	4.7	4.9	4.9			4.9	4.9			
34.0	3.3	3.4	3.4	3.4	3.3	3.9	4.0	4.1	4.1	4.1	4.1	4.2	4.4	4.2		4.3	4.4			
36.0	2.7	2.7	2.8	2.8	2.7	3.2	3.3	3.5	3.5	3.5	3.5	3.6	3.8	3.9		3.7	3.9	3.6		
38.0	2.1	2.1	2.2	2.2		2.6	2.8	2.9	3.0	3.0	2.9	3.1	3.3	3.4	3.4	3.2	3.4	3.3		
40.0			1.7	1.7		2.1	2.3	2.4	2.5	2.5	2.4	2.6	2.8	3.0	3.0	2.7	2.9	3.0		
42.0						1.6	1.8	1.9	2.0	2.0	1.9	2.1	2.4	2.5	2.5	2.2	2.5	2.7	2.6	
44.0									1.5	1.6		1.5	1.7	2.0	2.1	1.8	2.0	2.3	2.4	
46.0													1.6	1.7	1.7		1.7	2.0	2.1	2.2
48.0																	1.6	1.8	1.8	1.8
50.0																				1.5
θ(°)	61~ 84.5	62~ 84.5	62~ 84.5	63~ 84.5	67~ 84.5	62~ 84.5	64~ 84.5	65~ 84.5	66~ 84.5	69~ 84.5	64~ 84.5	66~ 84.5	69~ 84.5	72~ 84.5	73~ 84.5	68~ 84.5	69~ 84.5	72~ 84.5	76~ 84.5	77~ 84.5
標準フック											12.2t									
フック重量											440kg									
標準巻掛本数											1									

フルオートラフィングジブ

カウンタウエイト 78t、アウトリガ張出幅 8.0m
40.4mブーム+2.3m+フルオートラフィングジブ

単位:t

ジブ長さ(m) 作業半径 (m)	10.3m オフセット					17.2m オフセット					24.1m オフセット					31.0m オフセット									
	5°	15°	30°	45°	60°	5°	15°	30°	45°	60°	5°	15°	30°	45°	60°	5°	15°	30°	45°	60°					
9.0	38.4																								
10.0	36.0					16.7																			
11.0	33.8	31.6				16.7																			
12.0	31.9	30.2				16.7																			
14.0	28.6	27.3	25.2			16.7	16.7				16.0														
16.0	25.8	24.8	23.5	22.1	21.1	16.7	16.7				15.5					10.9									
18.0	23.5	22.6	21.6	20.9	20.3	16.7	16.7	16.7			15.0	13.5				10.8									
20.0	21.5	20.8	19.9	19.4	19.0	16.7	16.7	15.9			14.5	13.0				10.5									
22.0	19.8	19.2	18.5	18.0	17.7	16.7	16.7	15.2	14.0		13.9	12.5				10.3	9.2								
24.0	18.3	17.8	17.2	16.8	16.6	16.7	16.2	14.5	13.4	12.9	13.4	12.1	10.8			10.0	8.8								
26.0	16.7	16.5	16.0	15.7	15.5	15.9	15.4	13.9	13.0	12.5	12.9	11.7	10.5			9.7	8.4								
28.0	13.5	14.4	15.0	14.7	14.6	14.8	14.4	13.3	12.5	12.1	12.5	11.4	10.1	9.3		9.2	8.1								
30.0	10.7	11.6	12.5	13.1		13.8	13.5	12.8	12.1	11.8	12.1	11.1	9.8	9.0	8.5	8.8	7.8	6.7							
32.0	8.4	9.1	9.9	10.4		11.4	12.6	12.2	11.8	11.6	11.7	10.8	9.6	8.8	8.4	8.5	7.5	6.5							
34.0	6.3	6.9	7.7	8.0		9.3	10.5	11.5	11.3	11.2	11.3	10.4	9.3	8.6	8.3	8.1	7.2	6.2							
36.0	4.5	5.1	5.7	5.9		7.4	8.5	9.8	10.7	10.6	9.6	10.0	9.0	8.5	8.2	7.8	6.9	6.1	5.5						
38.0	2.9	3.4	3.9	4.0		5.8	6.8	7.9	8.6		7.9	9.3	8.8	8.3	8.1	7.5	6.7	5.9	5.3						
40.0						4.4	5.2	6.2	6.8		6.5	7.7	8.5	8.1	8.0	7.2	6.5	5.7	5.2	5.0					
42.0						3.1	3.8	4.7	5.1		5.2	6.3	7.8	7.9		7.0	6.3	5.5	5.1	5.0					
44.0						1.9	2.6	3.3	3.6		4.0	5.0	6.3	7.2		5.9	6.1	5.4	5.0	4.9					
46.0								2.0			2.9	3.8	5.0	5.7		4.8	5.9	5.3	4.9	4.8					
48.0											1.9	2.8	3.8	4.4		3.8	5.0	5.1	4.8						
50.0												1.8	2.7	3.1		2.9	4.0	5.0	4.7						
54.0																2.2	3.3	4.0							
θ(°)	45~ 84.5	46~ 84.5	48~ 84.5	48~ 84.5	64~ 84.5	45~ 84.5	47~ 84.5	47~ 84.5	52~ 84.5	65~ 84.5	46~ 84.5	48~ 84.5	51~ 84.5	53~ 84.5	69~ 84.5	50~ 84.5	50~ 84.5	56~ 84.5	59~ 84.5	72~ 84.5					
標準フック											35t					12.2t									
フック重量	80t					1550kg					35t					950kg					440kg				
標準巻掛本数	4										2					1									

カウンタウエイト 78t、アウトリガ張出幅 8.0m
45.4mブーム+2.3m+フルオートラフィングジブ

単位:t

ジブ長さ(m) 作業半径 (m)	10.3m オフセット					17.2m オフセット					24.1m オフセット					31.0m オフセット									
	5°	15°	30°	45°	60°	5°	15°	30°	45°	60°	5°	15°	30°	45°	60°	5°	15°	30°	45°	60°					
10.0	29.5																								
11.0	27.8																								
12.0	26.3	24.5				16.7																			
14.0	23.6	22.2	20.6			16.7					15.3														
16.0	21.4	20.3	19.0	18.0		16.7	16.7				14.8					10.4									
18.0	19.6	18.6	17.5	16.7	16.2	16.7	16.7				14.4					10.3									
20.0	18.0	17.2	16.2	15.6	15.1	16.4	15.4	14.3			14.0	12.8				10.1									
22.0	16.6	15.9	15.1	14.5	14.2	15.2	14.3	13.3			13.7	12.4				9.9	9.0								
24.0	15.4	14.8	14.1	13.6	13.3	14.1	13.3	12.5	11.9		13.0	12.0				9.6	8.7								
26.0	14.3	13.8	13.2	12.8	12.6	13.1	12.4	11.7	11.2	10.8	12.1	11.4	10.4			9.4	8.3								
28.0	13.4	12.9	12.4	12.0	11.9	12.2	11.6	11.0	10.5	10.2	11.3	10.7	9.9			9.2	8.0								
30.0	10.9	11.7	11.6	11.3	11.2	11.4	10.9	10.3	9.9	9.7	10.6	10.0	9.4	8.8		8.8	7.7	6.6							
32.0	8.5	9.3	10.2	10.7		10.7	10.2	9.7	9.4	9.2	9.9	9.4	8.9	8.5	8.2	8.4	7.4	6.4							
34.0	6.4	7.1	7.9	8.4		9.1	9.6	9.2	8.9	8.7	9.3	8.9	8.4	8.1	7.9	8.1	7.2	6.2							
36.0	4.6	5.3	5.9	6.3		7.3	8.4	8.7	8.4	8.3	8.8	8.4	7.9	7.7	7.5	7.8	6.9	6.0	5.5						
38.0	3.1	3.6	4.2	4.4		5.6	6.7	7.9	7.8	7.7	7.6	7.9	7.5	7.2	7.0	7.5	6.7	5.8	5.3						
40.0		2.1	2.6	2.8		4.2	5.1	6.2	7.0		6.2	7.2	6.9	6.7	6.5	7.2	6.5	5.7	5.2	5.0					
42.0						2.9	3.7	4.7	5.3		4.9	6.1	6.4	6.2	6.1	6.8	6.3	5.5	5.1	4.9					
44.0							2.5	3.4	3.8		3.7	4.8	5.9	5.8		5.6	6.1	5.4	5.0	4.8					
46.0									2.5		2.6	3.6	4.9	5.3		4.5	5.7	5.2	4.9	4.8					
48.0												2.6	3.7	4.5		3.5	4.7	5.0	4.8	4.7					
50.0													2.6	3.3		2.6	3.7	4.7	4.5						
54.0																		3.2	3.9						
θ(°)	51~ 84.5	49~ 84.5	50~ 84.5	51~ 84.5	66~ 84.5	53~ 84.5	52~ 84.5	55~ 84.5	53~ 84.5	65~ 84.5	53~ 84.5	55~ 84.5	57~ 84.5	60~ 84.5	71~ 84.5	54~ 84.5	59~ 84.5	60~ 84.5	63~ 84.5	72~ 84.5					
標準フック											35t					12.2t									
フック重量	950kg					950kg					35t					950kg					440kg				
標準巻掛本数	3										2					1									

カウンタウエイト 78t、アウトリガ張出幅 8.0m
50.5mブーム+2.3m+フルオートラフィングジブ

単位:t

ジブ長さ(m) 作業半径 (m)	10.3m オフセット					17.2m オフセット					24.1m オフセット					31.0m オフセット				
	5°	15°	30°	45°	60°	5°	15°	30°	45°	60°	5°	15°	30°	45°	60°	5°	15°	30°	45°	60°
11.0	21.2																			
12.0	20.0																			
14.0	17.8	16.8				16.5														
16.0	16.0	15.2	14.2			15.0					13.5									
18.0	14.5	13.9	13.1	12.4	11.9	13.6	12.5				12.4					9.1				
20.0	13.2	12.7	12.1	11.6	11.2	12.5	11.7				11.5					9.1				
22.0	12.1	11.6	11.1	10.7	10.5	11.4	10.8	9.8			10.7	9.6				9.1				
24.0	11.1	10.7	10.3	10.0	9.7	10.5	10.0	9.2	8.5		9.9	9.0				9.1	8.3			
26.0	10.2	9.9	9.5	9.2	9.1	9.7	9.3	8.7	8.1	7.7	9.1	8.5	7.5			8.7	7.8			
28.0	9.3	9.0	8.7	8.5	8.3	9.0	8.6	8.2	7.7	7.4	8.5	8.0	7.1			8.2	7.4			
30.0	8.3	8.1	7.8	7.6	7.5	8.2	7.9	7.6	7.4	7.1	7.8	7.5	6.8			7.7	7.0			
32.0	7.4	7.2	7.0	6.9	6.7	7.3	7.1	6.9	6.7	6.6	7.1	6.9	6.4	6.0		7.2	6.6	5.9		
34.0	6.6	6.4	6.3	6.1		6.5	6.4	6.2	6.1	6.0	6.4	6.2	6.1	5.7	5.4	6.6	6.3	5.6		
36.0	4.8	5.4	5.6	5.5		5.9	5.7	5.6	5.5	5.4	5.7	5.6	5.5	5.4	5.2	5.9	5.8	5.3		
38.0	3.2	3.8	4.5	4.8		5.2	5.1	5.0	4.9	4.9	5.1	5.0	5.0	4.9	4.8	5.3	5.3	5.1	4.7	
40.0			2.9	3.2		4.3	4.6	4.5	4.4	4.4	4.6	4.5	4.5	4.4	4.4	4.8	4.8	4.7	4.5	
42.0						3.0	3.9	4.0	4.0		4.1	4.0	4.0	4.0	3.9	4.3	4.3	4.3	4.0	4.0
44.0								3.6	3.5		3.6	3.6	3.6	3.6	3.5	3.9	3.9	3.9	3.9	3.7
46.0									2.9			3.2	3.2	3.2		3.4	3.5	3.5	3.5	3.5
48.0													2.8	2.8		3.0	3.1	3.1	3.1	3.1
50.0														2.5			2.7	2.8	2.8	2.8
54.0																		2.2	2.2	2.2
θ(°)	54~84.5	56~84.5	55~84.5	56~84.5	66~84.5	55~84.5	58~84.5	58~84.5	58~84.5	66~84.5	58~84.5	60~84.5	62~84.5	62~84.5	70~84.5	59~84.5	62~84.5	63~84.5	66~84.5	73~84.5
標準フック																35t				
フック重量																950kg				
標準巻掛本数																2				

カウンタウエイト 78t、アウトリガ張出幅 8.0m
55.6mブーム+2.3m+フルオートラフィングジブ

単位:t

ジブ長さ(m) 作業半径 (m)	10.3m オフセット					17.2m オフセット					24.1m オフセット					31.0m オフセット				
	5°	15°	30°	45°	60°	5°	15°	30°	45°	60°	5°	15°	30°	45°	60°	5°	15°	30°	45°	60°
12.0	14.6																			
14.0	14.6	14.5																		
16.0	13.9	13.2				12.0														
18.0	12.5	12.1	11.2			11.6	10.7				9.4									
20.0	11.3	11.0	10.4	9.9	9.5	10.7	9.8				9.4					6.4				
22.0	10.3	10.0	9.6	9.2	8.9	9.8	9.1	8.3			9.3	8.5				6.4				
24.0	9.3	9.1	8.8	8.6	8.4	8.9	8.5	7.8			8.6	7.9				6.4				
26.0	8.1	8.0	7.8	7.7	7.5	8.0	7.9	7.3	6.9		8.0	7.4				6.4	6.4			
28.0	7.0	6.9	6.8	6.7	6.6	7.0	6.9	6.8	6.5	6.2	7.3	6.9	6.3			6.4	6.4			
30.0	6.1	6.0	6.0	5.9	5.8	6.1	6.1	6.1	6.0	5.9	6.5	6.5	5.9			6.4	6.0			
32.0	5.2	5.2	5.2	5.1	5.0	5.3	5.3	5.3	5.3	5.3	5.7	5.7	5.6			5.8	5.6			
34.0	4.5	4.5	4.4	4.4	4.3	4.6	4.6	4.7	4.7	4.6	5.0	5.1	4.9			5.1	5.2	4.9		
36.0	3.8	3.8	3.8	3.7	3.7	3.9	4.0	4.1	4.1	4.0	4.4	4.5	4.6	4.5	4.3	4.5	4.6	4.5		
38.0	3.1	3.1	3.2	3.1		3.3	3.4	3.5	3.5	3.5	3.8	3.9	4.0	4.1	4.0	3.9	4.1	4.1		
40.0				2.6		2.8	2.9	3.0	3.0	3.0	3.2	3.4	3.5	3.6	3.6	3.4	3.6	3.7	3.5	
42.0							2.4	2.5	2.5	2.5	2.7	2.9	3.0	3.1	3.1	3.0	3.1	3.3	3.2	
44.0								2.0	2.1		2.3	2.4	2.6	2.7	2.7	2.5	2.7	2.9	2.9	2.8
46.0												2.0	2.2	2.3	2.3	2.1	2.3	2.5	2.6	2.6
48.0													1.8	1.9			1.9	2.1	2.3	2.3
50.0														1.5			1.6	1.8	1.9	2.0
θ(°)	58~84.5	59~84.5	61~84.5	60~84.5	64~84.5	60~84.5	61~84.5	62~84.5	64~84.5	66~84.5	62~84.5	63~84.5	65~84.5	66~84.5	71~84.5	64~84.5	64~84.5	69~84.5	73~84.5	75~84.5
標準フック																35t				
フック重量																950kg				
標準巻掛本数																2				

フルオートラフィングジブ

カウンタウエイト 78t、アウトリガ張出幅 8.0m
60.0mブーム+2.3m+フルオートラフィングジブ

単位:t

ジブ長さ(m) 作業半径 (m)	10.3m オフセット					17.2m オフセット					24.1m オフセット					31.0m オフセット				
	5°	15°	30°	45°	60°	5°	15°	30°	45°	60°	5°	15°	30°	45°	60°	5°	15°	30°	45°	60°
14.0	12.0																			
16.0	12.0	11.6				8.0														
18.0	11.0	10.6	9.9			8.0														
20.0	9.9	9.6	9.2	8.8		8.0	8.0													
22.0	8.9	8.7	8.5	8.1	7.9	8.0	8.0													
24.0	7.7	7.7	7.6	7.5	7.3	8.0	7.7	7.2												
26.0	6.7	6.6	6.6	6.5	6.4	7.1	7.1	6.7												
28.0	5.7	5.7	5.7	5.6	5.5	6.1	6.2	6.2	5.9											
30.0	4.8	4.8	4.8	4.8	4.7	5.3	5.4	5.4	5.4	5.4	5.5	5.6	5.3							
32.0	4.0	4.1	4.1	4.1	4.0	4.5	4.6	4.7	4.8	4.7	4.7	4.9	4.9							
34.0	3.3	3.4	3.4	3.4	3.3	3.9	4.0	4.1	4.1	4.1	4.1	4.2	4.4	4.2						
36.0	2.7	2.7	2.8	2.8	2.7	3.2	3.3	3.5	3.5	3.5	3.5	3.6	3.8	3.9						
38.0			2.2	2.2		2.6	2.8	2.9	3.0	3.0	2.9	3.1	3.3	3.4	3.4					
40.0							2.3	2.4	2.5	2.5	2.4	2.6	2.8	3.0	3.0					
42.0								1.9	2.0	2.0	1.9	2.1	2.4	2.5	2.5					
44.0									1.6			1.7	2.0	2.1	2.1					
46.0													1.6	1.7	1.7					
48.0																				
50.0																				
θ(°)	63~ 84.5	64~ 84.5	64~ 84.5	65~ 84.5	67~ 84.5	66~ 84.5	66~ 84.5	66~ 84.5	66~ 84.5	69~ 84.5	66~ 84.5	66~ 84.5	69~ 84.5	72~ 84.5	73~ 84.5	68~ 84.5	69~ 84.5	72~ 84.5	76~ 84.5	77~ 84.5
標準フック	12.2t																			
フック重量	440kg																			
標準巻掛本数	1																			

カウンタウエイト 78t、アウトリガ張出幅 6.8m
40.4mブーム+2.3m+フルオートラフィングジブ

単位:t

ジブ長さ(m) 作業半径 (m)	10.3m オフセット					17.2m オフセット					24.1m オフセット					31.0m オフセット				
	5°	15°	30°	45°	60°	5°	15°	30°	45°	60°	5°	15°	30°	45°	60°	5°	15°	30°	45°	60°
9.0	38.4																			
10.0	36.0					16.7														
11.0	33.8	31.6				16.7														
12.0	31.9	30.2				16.7														
14.0	28.6	27.3	25.2			16.7	16.7													
16.0	25.8	24.8	23.5	22.1	21.1	16.7	16.7													
18.0	23.5	22.6	21.6	20.9	20.3	16.7	16.7	16.7												
20.0	21.5	20.8	19.9	19.4	19.0	16.7	16.7	15.9												
22.0	19.8	19.2	18.5	18.0	17.7	16.7	16.7	15.2	14.0											
24.0	15.8	17.0	17.2	16.8	16.6	16.7	16.2	14.5	13.4	12.9	13.4	12.1	10.8							
26.0	12.4	13.4	14.8	15.6	15.5	15.6	15.4	13.9	13.0	12.5	12.9	11.7	10.5							
28.0	9.6	10.5	11.6	12.3	12.5	12.7	14.2	13.3	12.5	12.1	12.5	11.4	10.1	9.3						
30.0	7.2	8.0	8.9	9.5		10.2	11.6	12.8	12.1	11.8	12.1	11.1	9.8	9.0	8.5	8.8	7.8			
32.0	5.1	5.8	6.6	7.1		8.1	9.3	11.0	11.8	11.6	10.2	10.8	9.6	8.8	8.4	8.5	7.5	6.5		
34.0	3.3	3.9	4.6	4.9		6.2	7.4	8.8	9.9	10.3	8.4	10.0	9.3	8.6	8.3	8.1	7.2	6.2		
36.0				3.1		4.6	5.6	6.9	7.8	8.1	6.7	8.2	9.0	8.5	8.2	7.8	6.9	6.1	5.5	
38.0						3.2	4.1	5.2	5.9		5.2	6.6	8.4	8.3	8.1	7.2	6.7	5.9	5.3	
40.0							2.7	3.7	4.3		3.9	5.2	6.8	8.0	8.0	5.9	6.5	5.7	5.2	5.0
42.0								2.3	2.7		2.8	3.9	5.3	6.4		4.7	6.2	5.5	5.1	5.0
44.0												2.7	4.0	4.9		3.6	5.0	5.4	5.0	4.9
46.0													2.8	3.6		2.7	3.9	5.3	4.9	4.8
48.0																	2.9	4.4	4.8	
50.0																		3.4	4.4	
θ(°)	51~ 84.5	53~ 84.5	55~ 84.5	52~ 84.5	64~ 84.5	54~ 84.5	53~ 84.5	54~ 84.5	55~ 84.5	65~ 84.5	54~ 84.5	55~ 84.5	57~ 84.5	60~ 84.5	69~ 84.5	55~ 84.5	57~ 84.5	60~ 84.5	64~ 84.5	72~ 84.5
標準フック	80t																			
フック重量	1550kg					35t					950kg					12.2t				
標準巻掛本数	4					2					1					1				

カウンタウエイト 78t、アウトリガ張出幅 6.8m
45.4mブーム+2.3m+フルオートラフィングジブ

単位:t

ジブ長さ(m) 作業半径 (m)	10.3m オフセット					17.2m オフセット					24.1m オフセット					31.0m オフセット				
	5°	15°	30°	45°	60°	5°	15°	30°	45°	60°	5°	15°	30°	45°	60°	5°	15°	30°	45°	60°
10.0	29.5																			
11.0	27.8																			
12.0	26.3	24.5				16.7														
14.0	23.6	22.2	20.6			16.7					15.3									
16.0	21.4	20.3	19.0	18.0		16.7	16.7				14.8					10.4				
18.0	19.6	18.6	17.5	16.7	16.2	16.7	16.7				14.4					10.3				
20.0	18.0	17.2	16.2	15.6	15.1	16.4	15.4	14.3			14.0	12.8				10.1				
22.0	16.6	15.9	15.1	14.5	14.2	15.2	14.3	13.3			13.7	12.4				9.9	9.0			
24.0	15.4	14.8	14.1	13.6	13.3	14.1	13.3	12.5	11.9		13.0	12.0				9.6	8.7			
26.0	12.5	13.6	13.2	12.8	12.6	13.1	12.4	11.7	11.2	10.8	12.1	11.4	10.4			9.4	8.3			
28.0	9.7	10.7	11.9	12.0	11.9	12.2	11.6	11.0	10.5	10.2	11.3	10.7	9.9			9.2	8.0			
30.0	7.3	8.1	9.2	9.9	10.1	10.0	10.9	10.3	9.9	9.7	10.6	10.0	9.4	8.8		8.8	7.7	6.6		
32.0	5.2	6.0	6.9	7.4		7.9	9.2	9.7	9.4	9.2	9.9	9.4	8.9	8.5	8.2	8.4	7.4	6.4		
34.0	3.4	4.1	4.9	5.3		6.0	7.3	8.8	8.9	8.7	8.1	8.9	8.4	8.1	7.9	8.1	7.2	6.2		
36.0			3.1	3.5		4.4	5.5	6.9	7.9	8.3	6.4	8.0	7.9	7.7	7.5	7.8	6.9	6.0	5.5	
38.0							4.0	5.2	6.1	6.3	5.0	6.4	7.5	7.2	7.0	6.9	6.7	5.8	5.3	
40.0								3.7	4.4		3.7	5.0	6.7	6.7	6.5	5.6	6.5	5.7	5.2	5.0
42.0												3.7	5.3	6.2	6.1	4.4	5.9	5.5	5.1	4.9
44.0													4.0	5.0		3.3	4.7	5.4	5.0	4.8
46.0														3.7			3.6	5.2	4.9	4.8
48.0																		4.3	4.8	4.7
50.0																		3.3	4.4	
θ(°)	56~ 84.5	57~ 84.5	56~ 84.5	57~ 84.5	66~ 84.5	60~ 84.5	60~ 84.5	60~ 84.5	62~ 84.5	65~ 84.5	59~ 84.5	61~ 84.5	64~ 84.5	65~ 84.5	71~ 84.5	60~ 84.5	62~ 84.5	64~ 84.5	68~ 84.5	72~ 84.5
標準フック	35t					35t					12.2t									
フック重量	950kg					950kg					440kg									
標準巻掛本数	3					2					1									

カウンタウエイト 78t、アウトリガ張出幅 6.8m
50.5mブーム+2.3m+フルオートラフィングジブ

単位:t

ジブ長さ(m) 作業半径 (m)	10.3m オフセット					17.2m オフセット					24.1m オフセット					31.0m オフセット				
	5°	15°	30°	45°	60°	5°	15°	30°	45°	60°	5°	15°	30°	45°	60°	5°	15°	30°	45°	60°
11.0	21.2																			
12.0	20.0																			
14.0	17.8	16.8				16.5														
16.0	16.0	15.2	14.2			15.0					13.5									
18.0	14.5	13.9	13.1	12.4	11.9	13.6	12.5				12.4					9.1				
20.0	13.2	12.7	12.1	11.6	11.2	12.5	11.7				11.5					9.1				
22.0	12.1	11.6	11.1	10.7	10.5	11.4	10.8	9.8			10.7	9.6				9.1				
24.0	11.1	10.7	10.3	10.0	9.7	10.5	10.0	9.2	8.5		9.9	9.0				9.1	8.3			
26.0	10.2	9.9	9.5	9.2	9.1	9.7	9.3	8.7	8.1	7.7	9.1	8.5	7.5			8.7	7.8			
28.0	9.3	9.0	8.7	8.5	8.3	9.0	8.6	8.2	7.7	7.4	8.5	8.0	7.1			8.2	7.4			
30.0	7.4	8.1	7.8	7.6	7.5	8.2	7.9	7.6	7.4	7.1	7.8	7.5	6.8			7.7	7.0			
32.0	5.3	6.1	7.0	6.9	6.7	7.3	7.1	6.9	6.7	6.6	7.1	6.9	6.4	6.0		7.2	6.6	5.9		
34.0		4.3	5.1	5.6		6.1	6.4	6.2	6.1	6.0	6.4	6.2	6.1	5.7	5.4	6.6	6.3	5.6		
36.0				3.8		4.5	5.7	5.6	5.5	5.4	5.7	5.6	5.5	5.4	5.2	5.9	5.8	5.3		
38.0							4.1	5.0	4.9	4.9	4.9	5.0	4.9	4.8	4.8	5.3	5.3	5.1	4.7	
40.0								3.9	4.4	4.4		4.5	4.5	4.4	4.4	4.8	4.8	4.7	4.5	
42.0													4.0	4.0	3.9	4.3	4.3	4.3	4.2	4.0
44.0													3.6	3.6	3.5		3.9	3.9	3.9	3.7
46.0														3.2				3.5	3.5	3.5
48.0																		3.1	3.1	3.1
50.0																		2.8	2.8	2.8
θ(°)	61~ 84.5	60~ 84.5	62~ 84.5	61~ 84.5	66~ 84.5	61~ 84.5	62~ 84.5	63~ 84.5	65~ 84.5	66~ 84.5	64~ 84.5	65~ 84.5	66~ 84.5	66~ 84.5	70~ 84.5	64~ 84.5	67~ 84.5	68~ 84.5	70~ 84.5	73~ 84.5
標準フック	35t					35t					12.2t									
フック重量	950kg					950kg					440kg									
標準巻掛本数	2					2					1									

フルオートラフィングジブ

カウンタウエイト 78t、アウトリガ張出幅 6.8m
55.6mブーム+2.3m+フルオートラフィングジブ

単位:t

ジブ長さ(m) 作業半径 (m)	10.3m オフセット					17.2m オフセット					24.1m オフセット					31.0m オフセット				
	5°	15°	30°	45°	60°	5°	15°	30°	45°	60°	5°	15°	30°	45°	60°	5°	15°	30°	45°	60°
12.0	14.6																			
14.0	14.6	14.5																		
16.0	13.9	13.2				12.0														
18.0	12.5	12.1	11.2			11.6	10.7				9.4									
20.0	11.3	11.0	10.4	9.9	9.5	10.7	9.8				9.4					6.4				
22.0	10.3	10.0	9.6	9.2	8.9	9.8	9.1	8.3			9.3	8.5				6.4				
24.0	9.3	9.1	8.8	8.6	8.4	8.9	8.5	7.8			8.6	7.9				6.4				
26.0	8.1	8.0	7.8	7.7	7.5	8.0	7.9	7.3	6.9		8.0	7.4				6.4	6.4			
28.0	7.0	6.9	6.8	6.7	6.6	7.0	6.9	6.8	6.5	6.2	7.3	6.9	6.3			6.4	6.4			
30.0	6.1	6.0	6.0	5.9	5.8	6.1	6.1	6.0	5.9	5.9	6.5	6.5	5.9			6.4	6.0			
32.0	5.2	5.2	5.2	5.1	5.0	5.3	5.3	5.3	5.3	5.3	5.7	5.7	5.6			5.8	5.6			
34.0		4.5	4.4	4.4	4.3	4.6	4.6	4.7	4.7	4.6	5.0	5.1	5.1	4.9		5.1	5.2	4.9		
36.0						4.0	4.1	4.1	4.0	4.4	4.5	4.6	4.5	4.3		4.5	4.6	4.5		
38.0							3.5	3.5	3.5	3.8	3.9	4.0	4.1	4.0		3.9	4.1	4.1		
40.0								3.0	3.0		3.4	3.5	3.6	3.6		3.4	3.6	3.7	3.5	
42.0												3.0	3.1	3.1		3.1	3.3	3.2		
44.0												2.6	2.7	2.7		2.7	2.9	2.9	2.8	
46.0													2.3	2.3			2.5	2.6	2.6	
48.0																	2.1	2.3	2.3	
50.0																		1.9	2.0	
θ (°)	64~ 84.5	63~ 84.5	65~ 84.5	66~ 84.5	67~ 84.5	66~ 84.5	67~ 84.5	68~ 84.5	68~ 84.5	68~ 84.5	66~ 84.5	68~ 84.5	68~ 84.5	70~ 84.5	71~ 84.5	69~ 84.5	69~ 84.5	71~ 84.5	73~ 84.5	75~ 84.5
標準フック											12.2t									
フック重量											440kg									
標準巻掛本数											1									

カウンタウエイト 78t、アウトリガ張出幅 6.8m
60.0mブーム+2.3m+フルオートラフィングジブ

単位:t

ジブ長さ(m) 作業半径 (m)	10.3m オフセット					17.2m オフセット					24.1m オフセット					31.0m オフセット				
	5°	15°	30°	45°	60°	5°	15°	30°	45°	60°	5°	15°	30°	45°	60°	5°	15°	30°	45°	60°
14.0	12.0																			
16.0	12.0	11.6				8.0														
18.0	11.0	10.6	9.9			8.0					7.1									
20.0	9.9	9.6	9.2	8.8		8.0	8.0				7.1					5.7				
22.0	8.9	8.7	8.5	8.1	7.9	8.0	8.0				7.1					5.7				
24.0	7.7	7.7	7.6	7.5	7.3	8.0	7.7	7.2			7.1	6.9				5.7				
26.0	6.7	6.6	6.6	6.5	6.4	7.1	7.1	6.7			7.1	6.6				5.7				
28.0	5.7	5.7	5.7	5.6	5.5	6.1	6.2	6.2	5.9		6.3	6.2				5.7				
30.0	4.8	4.8	4.8	4.8	4.7	5.3	5.4	5.4	5.4	5.4	5.5	5.6	5.3			5.6	5.2			
32.0		4.1	4.1	4.1	4.0	4.5	4.6	4.7	4.8	4.7	4.7	4.9	4.9			4.9	4.9			
34.0				3.4	3.3	3.9	4.0	4.1	4.1	4.1	4.1	4.2	4.4	4.2		4.3	4.4			
36.0						3.3	3.5	3.5	3.5	3.5	3.6	3.8	3.9			3.7	3.9	3.6		
38.0							2.9	3.0	3.0	3.0	3.1	3.3	3.4	3.4		3.2	3.4	3.3		
40.0								2.5	2.5			2.8	3.0	3.0		2.9	3.0			
42.0												2.4	2.5	2.5		2.5	2.7	2.6		
44.0													2.1	2.1			2.3	2.4		
46.0																2.0	2.1	2.2		
48.0																		1.8	1.8	
50.0																			1.5	
θ (°)	68~ 84.5	68~ 84.5	69~ 84.5	69~ 84.5	69~ 84.5	69~ 84.5	69~ 84.5	70~ 84.5	70~ 84.5	71~ 84.5	70~ 84.5	71~ 84.5	72~ 84.5	73~ 84.5	75~ 84.5	72~ 84.5	72~ 84.5	74~ 84.5	76~ 84.5	77~ 84.5
標準フック											12.2t									
フック重量											440kg									
標準巻掛本数											1									

カウンタウエイト 58t、アウトリガ張出幅 8.5m
40.4mブーム+2.3m+フルオートラフィングジブ

単位:t

ジブ長さ(m) 作業半径 (m)	10.3m オフセット					17.2m オフセット					24.1m オフセット					31.0m オフセット				
	5°	15°	30°	45°	60°	5°	15°	30°	45°	60°	5°	15°	30°	45°	60°	5°	15°	30°	45°	60°
9.0	38.4																			
10.0	36.0					16.7														
11.0	33.8	31.6				16.7														
12.0	31.9	30.2				16.7														
14.0	28.6	27.3	25.2			16.7	16.7				16.0									
16.0	25.8	24.8	23.5	22.1	21.1	16.7	16.7				15.5					10.9				
18.0	23.5	22.6	21.6	20.9	20.3	16.7	16.7	16.7			15.0	13.5				10.8				
20.0	21.5	20.8	19.9	19.4	19.0	16.7	16.7	15.9			14.5	13.0				10.5				
22.0	19.2	19.2	18.5	18.0	17.7	16.7	16.7	15.2	14.0		13.9	12.5				10.3	9.2			
24.0	15.1	16.4	17.2	16.8	16.6	16.7	16.2	14.5	13.4	12.9	13.4	12.1	10.8			10.0	8.8			
26.0	11.7	12.8	14.1	15.1	15.4	15.0	15.4	13.9	13.0	12.5	12.9	11.7	10.5			9.7	8.4			
28.0	8.8	9.8	10.9	11.7	11.9	12.0	13.7	13.3	12.5	12.1	12.5	11.4	10.1	9.3		9.2	8.1			
30.0	6.4	7.2	8.2	8.8		9.5	11.0	12.8	12.1	11.8	11.8	11.1	9.8	9.0	8.5	8.8	7.8	6.7		
32.0	4.3	5.1	5.9	6.4		7.4	8.7	10.4	11.7	11.6	9.6	10.8	9.6	8.8	8.4	8.5	7.5	6.5		
34.0			3.9	4.2		5.5	6.7	8.2	9.3	9.7	7.7	9.4	9.3	8.6	8.3	8.1	7.2	6.2		
36.0						3.9	5.0	6.3	7.2	7.5	6.1	7.6	9.0	8.5	8.2	7.8	6.9	6.1	5.5	
38.0							3.4	4.6	5.3		4.6	6.0	7.8	8.3	8.1	6.7	6.7	5.9	5.3	
40.0								3.1	3.6		3.3	4.6	6.2	7.5	8.0	5.3	6.5	5.7	5.2	5.0
42.0												3.3	4.8	5.9		4.1	5.6	5.5	5.1	5.0
44.0													3.5	4.4		3.1	4.4	5.4	5.0	4.9
46.0														3.0			3.4	5.1	4.9	4.8
48.0																		3.9	4.8	
50.0																		2.9	3.9	
θ(°)	54~84.5	56~84.5	55~84.5	55~84.5	64~84.5	56~84.5	56~84.5	57~84.5	58~84.5	65~84.5	56~84.5	58~84.5	59~84.5	60~84.5	69~84.5	57~84.5	59~84.5	60~84.5	64~84.5	72~84.5
標準フック	80t					35t					12.2t									
フック重量	1550kg					950kg					440kg									
標準巻掛本数	4					2					1									

カウンタウエイト 58t、アウトリガ張出幅 8.5m
45.4mブーム+2.3m+フルオートラフィングジブ

単位:t

ジブ長さ(m) 作業半径 (m)	10.3m オフセット					17.2m オフセット					24.1m オフセット					31.0m オフセット				
	5°	15°	30°	45°	60°	5°	15°	30°	45°	60°	5°	15°	30°	45°	60°	5°	15°	30°	45°	60°
10.0	29.5																			
11.0	27.8																			
12.0	26.3	24.5				16.7														
14.0	23.6	22.2	20.6			16.7					15.3									
16.0	21.4	20.3	19.0	18.0		16.7	16.7				14.8					10.4				
18.0	19.6	18.6	17.5	16.7	16.2	16.7	16.7				14.4					10.3				
20.0	18.0	17.2	16.2	15.6	15.1	16.4	15.4	14.3			14.0	12.8				10.1				
22.0	16.6	15.9	15.1	14.5	14.2	15.2	14.3	13.3			13.7	12.4				9.9	9.0			
24.0	15.3	14.8	14.1	13.6	13.3	14.1	13.3	12.5	11.9		13.0	12.0				9.6	8.7			
26.0	11.8	13.0	13.2	12.8	12.6	13.1	12.4	11.7	11.2	10.8	12.1	11.4	10.4			9.4	8.3			
28.0	9.0	10.0	11.2	12.0	11.9	11.8	11.6	11.0	10.5	10.2	11.3	10.7	9.9			9.2	8.0			
30.0	6.5	7.4	8.5	9.2	9.4	9.3	10.9	10.3	9.9	9.7	10.6	10.0	9.4	8.8		8.8	7.7	6.6		
32.0	4.5	5.2	6.2	6.7		7.2	8.6	9.7	9.4	9.2	9.3	9.4	8.9	8.5	8.2	8.4	7.4	6.4		
34.0			4.2	4.6		5.4	6.6	8.2	8.9	8.7	7.4	8.9	8.4	8.1	7.9	8.1	7.2	6.2		
36.0							4.9	6.3	7.3	7.7	5.8	7.4	7.9	7.7	7.5	7.8	6.9	6.0	5.5	
38.0								4.6	5.5	5.7	4.3	5.8	7.5	7.2	7.0	6.3	6.7	5.8	5.3	
40.0									3.8			4.4	6.1	6.7	6.5	5.0	6.5	5.7	5.2	5.0
42.0													4.7	5.9	6.1	3.8	5.4	5.5	5.1	4.9
44.0														4.5			4.2	5.4	5.0	4.8
46.0																		4.9	4.9	4.8
48.0																		3.8	4.8	4.7
50.0																			3.9	
θ(°)	58~84.5	60~84.5	59~84.5	60~84.5	66~84.5	62~84.5	62~84.5	62~84.5	62~84.5	65~84.5	61~84.5	63~84.5	66~84.5	67~84.5	71~84.5	61~84.5	64~84.5	66~84.5	68~84.5	72~84.5
標準フック	35t					35t					12.2t									
フック重量	950kg					950kg					440kg									
標準巻掛本数	3					2					1									

フルオートラフィングジブ

カウンタウエイト 58t、アウトリガ張出幅 8.5m
50.5mブーム+2.3m+フルオートラフィングジブ

単位:t

ジブ長さ(m) 作業半径 (m)	10.3m オフセット					17.2m オフセット					24.1m オフセット					31.0m オフセット				
	5°	15°	30°	45°	60°	5°	15°	30°	45°	60°	5°	15°	30°	45°	60°	5°	15°	30°	45°	60°
11.0	21.2																			
12.0	20.0																			
14.0	17.8	16.8				16.5														
16.0	16.0	15.2	14.2			15.0					13.5									
18.0	14.5	13.9	13.1	12.4	11.9	13.6	12.5				12.4					9.1				
20.0	13.2	12.7	12.1	11.6	11.2	12.5	11.7				11.5					9.1				
22.0	12.1	11.6	11.1	10.7	10.5	11.4	10.8	9.8			10.7	9.6				9.1				
24.0	11.1	10.7	10.3	10.0	9.7	10.5	10.0	9.2	8.5		9.9	9.0				9.1	8.3			
26.0	10.2	9.9	9.5	9.2	9.1	9.7	9.3	8.7	8.1	7.7	9.1	8.5	7.5			8.7	7.8			
28.0	9.1	9.0	8.7	8.5	8.3	9.0	8.6	8.2	7.7	7.4	8.5	8.0	7.1			8.2	7.4			
30.0	6.7	7.6	7.8	7.6	7.5	8.2	7.9	7.6	7.4	7.1	7.8	7.5	6.8			7.7	7.0			
32.0	4.6	5.4	6.4	6.9	6.7	7.3	7.1	6.9	6.7	6.6	7.1	6.9	6.4	6.0		7.2	6.6	5.9		
34.0			4.4	4.9		5.5	6.4	6.2	6.1	6.0	6.4	6.2	6.1	5.7	5.4	6.6	6.3	5.6		
36.0						5.0	5.6	5.5	5.4	5.4	5.7	5.6	5.5	5.4	5.2	5.9	5.8	5.3		
38.0							4.8	4.9	4.9			5.0	5.0	4.9	4.8	5.3	5.3	5.1	4.7	
40.0									4.4				4.5	4.4	4.4	4.8	4.8	4.7	4.5	
42.0													4.0	4.0	3.9		4.3	4.3	4.2	4.0
44.0														3.6	3.5			3.9	3.9	3.7
46.0																	3.5	3.5	3.5	
48.0																		3.1	3.1	3.1
50.0																				2.8
θ (°)	62~ 84.5	63~ 84.5	62~ 84.5	63~ 84.5	66~ 84.5	63~ 84.5	64~ 84.5	65~ 84.5	67~ 84.5	66~ 84.5	65~ 84.5	67~ 84.5	68~ 84.5	68~ 84.5	70~ 84.5	65~ 84.5	68~ 84.5	70~ 84.5	72~ 84.5	73~ 84.5
標準フック																12.2t				
フック重量																440kg				
標準巻掛本数																1				

カウンタウエイト 58t、アウトリガ張出幅 8.5m
55.6mブーム+2.3m+フルオートラフィングジブ

単位:t

ジブ長さ(m) 作業半径 (m)	10.3m オフセット					17.2m オフセット					24.1m オフセット					31.0m オフセット				
	5°	15°	30°	45°	60°	5°	15°	30°	45°	60°	5°	15°	30°	45°	60°	5°	15°	30°	45°	60°
12.0	14.6																			
14.0	14.6	14.5																		
16.0	13.9	13.2				12.0														
18.0	12.5	12.1	11.2			11.6	10.7				9.4									
20.0	11.3	11.0	10.4	9.9	9.5	10.7	9.8				9.4					6.4				
22.0	10.3	10.0	9.6	9.2	8.9	9.8	9.1	8.3			9.3	8.5				6.4				
24.0	9.3	9.1	8.8	8.6	8.4	8.9	8.5	7.8			8.6	7.9				6.4				
26.0	8.1	8.0	7.8	7.7	7.5	8.0	7.9	7.3	6.9		8.0	7.4				6.4	6.4			
28.0	7.0	6.9	6.8	6.7	6.6	7.0	6.9	6.8	6.5	6.2	7.3	6.9	6.3			6.4	6.4			
30.0	6.1	6.0	6.0	5.9	5.8	6.1	6.1	6.1	6.0	5.9	6.5	6.5	5.9			6.4	6.0			
32.0		5.2	5.2	5.1	5.0	5.3	5.3	5.3	5.3	5.3	5.7	5.7	5.6			5.8	5.6			
34.0				4.4	4.3		4.6	4.7	4.7	4.6	5.0	5.1	5.1	4.9		5.1	5.2	4.9		
36.0							4.1	4.1	4.0	4.4	4.5	4.5	4.6	4.5	4.3	4.5	4.6	4.5		
38.0									3.5	3.5		3.9	4.0	4.1	4.0	3.9	4.1	4.1		
40.0													3.5	3.6	3.6		3.6	3.7	3.5	
42.0													3.0	3.1	3.1		3.1	3.3	3.2	
44.0														2.7	2.7			2.9	2.9	2.8
46.0																	2.5	2.6	2.6	2.6
48.0																			2.3	2.3
50.0																				2.0
θ (°)	66~ 84.5	65~ 84.5	67~ 84.5	66~ 84.5	67~ 84.5	68~ 84.5	68~ 84.5	70~ 84.5	70~ 84.5	70~ 84.5	68~ 84.5	70~ 84.5	70~ 84.5	71~ 84.5	73~ 84.5	70~ 84.5	70~ 84.5	72~ 84.5	74~ 84.5	75~ 84.5
標準フック																12.2t				
フック重量																440kg				
標準巻掛本数																1				

カウンタウエイト 58t、アウトリガ張出幅 8.5m
60.0mブーム+2.3m+フルオートラフィングジブ

単位:t

ジブ長さ(m) 作業半径 (m)	10.3m オフセット					17.2m オフセット					24.1m オフセット					31.0m オフセット				
	5°	15°	30°	45°	60°	5°	15°	30°	45°	60°	5°	15°	30°	45°	60°	5°	15°	30°	45°	60°
14.0	12.0					8.0														
16.0	12.0	11.6				8.0														
18.0	11.0	10.6	9.9								7.1									
20.0	9.9	9.6	9.2	8.8		8.0	8.0				7.1					5.7				
22.0	8.9	8.7	8.5	8.1	7.9	8.0	8.0				7.1					5.7				
24.0	7.7	7.7	7.6	7.5	7.3	8.0	7.7	7.2			7.1	6.9				5.7				
26.0	6.7	6.6	6.6	6.5	6.4	7.1	7.1	6.7			7.1	6.6				5.7				
28.0	5.7	5.7	5.7	5.6	5.5	6.1	6.2	6.2	5.9		6.3	6.2				5.7				
30.0		4.8	4.8	4.8	4.7	5.3	5.4	5.4	5.4	5.4	5.5	5.6	5.3			5.6	5.2			
32.0			4.1	4.1	4.0	4.5	4.6	4.7	4.8	4.7	4.7	4.9	4.9			4.9	4.9			
34.0							4.0	4.1	4.1	4.1	4.1	4.2	4.4	4.2		4.3	4.4			
36.0								3.5	3.5	3.5		3.6	3.8	3.9		3.7	3.9	3.6		
38.0									3.0	3.0			3.3	3.4	3.4		3.4	3.3		
40.0													2.8	3.0	3.0		2.9	3.0		
42.0														2.5	2.5				2.7	2.6
44.0															2.1				2.3	2.4
46.0																			2.1	2.2
48.0																				1.8
θ(°)	70~ 84.5	70~ 84.5	69~ 84.5	70~ 84.5	71~ 84.5	70~ 84.5	71~ 84.5	72~ 84.5	72~ 84.5	73~ 84.5	72~ 84.5	72~ 84.5	74~ 84.5	75~ 84.5	75~ 84.5	73~ 84.5	74~ 84.5	76~ 84.5	78~ 84.5	79~ 84.5
標準フック	12.2t																			
フック重量	440kg																			
標準巻掛本数	1																			

カウンタウエイト 58t、アウトリガ張出幅 8.0m
40.4mブーム+2.3m+フルオートラフィングジブ

単位:t

ジブ長さ(m) 作業半径 (m)	10.3m オフセット					17.2m オフセット					24.1m オフセット					31.0m オフセット				
	5°	15°	30°	45°	60°	5°	15°	30°	45°	60°	5°	15°	30°	45°	60°	5°	15°	30°	45°	60°
9.0	38.4																			
10.0	36.0					16.7														
11.0	33.8	31.6				16.7														
12.0	31.9	30.2				16.7														
14.0	28.6	27.3	25.2			16.7	16.7				16.0									
16.0	25.8	24.8	23.5	22.1	21.1	16.7	16.7				15.5					10.9				
18.0	23.5	22.6	21.6	20.9	20.3	16.7	16.7	16.7			15.0	13.5				10.8				
20.0	21.5	20.8	19.9	19.4	19.0	16.7	16.7	15.9			14.5	13.0				10.5				
22.0	17.3	18.5	18.5	18.0	17.7	16.7	16.7	15.2	14.0		13.9	12.5				10.3	9.2			
24.0	13.3	14.6	16.1	16.8	16.6	16.6	16.2	14.5	13.4	12.9	13.4	12.1	10.8			10.0	8.8			
26.0	10.1	11.2	12.5	13.4	13.8	13.3	15.1	13.9	13.0	12.5	12.9	11.7	10.5			9.7	8.4			
28.0	7.4	8.3	9.5	10.2	10.4	10.5	12.2	13.3	12.5	12.1	12.5	11.4	10.1	9.3		9.2	8.1			
30.0	5.1	5.9	6.9	7.5		8.2	9.6	11.5	12.1	11.8	10.4	11.1	9.8	9.0	8.5	8.8	7.8	6.7		
32.0			4.7	5.1		6.2	7.5	9.1	10.4	11.0	8.4	10.2	9.6	8.8	8.4	8.5	7.5	6.5		
34.0						4.4	5.6	7.1	8.1	8.6	6.6	8.2	9.3	8.6	8.3	8.1	7.2	6.2		
36.0							3.9	5.2	6.1	6.4	5.0	6.5	8.5	8.5	8.2	7.1	6.9	6.1	5.5	
38.0								3.6	4.3		3.6	5.0	6.8	8.2	8.1	5.6	6.7	5.9	5.3	
40.0												3.6	5.3	6.5	7.1	4.4	6.0	5.7	5.2	5.0
42.0													3.9	5.0		3.3	4.7	5.5	5.1	5.0
44.0														3.6			3.6	5.4	5.0	4.9
46.0																		4.3	4.9	4.8
48.0																		3.2	4.4	
50.0																		3.2		
θ(°)	57~ 84.5	58~ 84.5	58~ 84.5	58~ 84.5	64~ 84.5	59~ 84.5	58~ 84.5	59~ 84.5	61~ 84.5	65~ 84.5	58~ 84.5	60~ 84.5	62~ 84.5	62~ 84.5	69~ 84.5	59~ 84.5	61~ 84.5	63~ 84.5	64~ 84.5	72~ 84.5
標準フック	80t																			
フック重量	1550kg					35t										12.2t				
標準巻掛本数	4					2										1				

フルオートラフィングジブ

カウンタウエイト 58t、アウトリガ張出幅 8.0m
45.4mブーム+2.3m+フルオートラフィングジブ

単位:t

ジブ長さ(m) 作業半径 (m)	10.3m オフセット					17.2m オフセット					24.1m オフセット					31.0m オフセット				
	5°	15°	30°	45°	60°	5°	15°	30°	45°	60°	5°	15°	30°	45°	60°	5°	15°	30°	45°	60°
10.0	29.5																			
11.0	27.8																			
12.0	26.3	24.5				16.7														
14.0	23.6	22.2	20.6			16.7					15.3									
16.0	21.4	20.3	19.0	18.0		16.7	16.7				14.8					10.4				
18.0	19.6	18.6	17.5	16.7	16.2	16.7	16.7				14.4					10.3				
20.0	18.0	17.2	16.2	15.6	15.1	16.4	15.4	14.3			14.0	12.8				10.1				
22.0	16.6	15.9	15.1	14.5	14.2	15.2	14.3	13.3			13.7	12.4				9.9	9.0			
24.0	13.5	14.7	14.1	13.6	13.3	14.1	13.3	12.5	11.9		13.0	12.0				9.6	8.7			
26.0	10.2	11.3	12.8	12.8	12.6	13.1	12.4	11.7	11.2	10.8	12.1	11.4	10.4			9.4	8.3			
28.0	7.5	8.5	9.7	10.6	10.9	10.4	11.6	11.0	10.5	10.2	11.3	10.7	9.9			9.2	8.0			
30.0	5.2	6.1	7.2	7.9	8.0	8.0	9.5	10.3	9.9	9.7	10.1	10.0	9.4	8.8		8.8	7.7	6.6		
32.0			5.0	5.5		6.0	7.3	9.1	9.4	9.2	8.1	9.4	8.9	8.5	8.2	8.4	7.4	6.4		
34.0							5.5	7.0	8.2	8.7	6.3	8.0	8.4	8.1	7.9	8.1	7.2	6.2		
36.0								5.2	6.2	6.7	4.7	6.3	7.9	7.7	7.5	6.7	6.9	6.0	5.5	
38.0									4.5	4.7		4.8	6.7	7.2	7.0	5.3	6.7	5.8	5.3	
40.0													5.2	6.5	6.5		5.7	5.7	5.2	5.0
42.0														5.0	5.6		4.5	5.5	5.1	4.9
44.0																		5.3	5.0	4.8
46.0																		4.1	4.9	4.8
48.0																			4.3	
θ (°)	60~ 84.5	62~ 84.5	62~ 84.5	63~ 84.5	66~ 84.5	64~ 84.5	64~ 84.5	65~ 84.5	64~ 84.5	65~ 84.5	63~ 84.5	65~ 84.5	68~ 84.5	69~ 84.5	71~ 84.5	65~ 84.5	66~ 84.5	68~ 84.5	70~ 84.5	74~ 84.5
標準フック	35t					35t					12.2t									
フック重量	950kg					950kg					440kg									
標準巻掛本数	3					2					1									

カウンタウエイト 58t、アウトリガ張出幅 8.0m
50.5mブーム+2.3m+フルオートラフィングジブ

単位:t

ジブ長さ(m) 作業半径 (m)	10.3m オフセット					17.2m オフセット					24.1m オフセット					31.0m オフセット				
	5°	15°	30°	45°	60°	5°	15°	30°	45°	60°	5°	15°	30°	45°	60°	5°	15°	30°	45°	60°
11.0	21.2																			
12.0	20.0																			
14.0	17.8	16.8				16.5														
16.0	16.0	15.2	14.2			15.0					13.5									
18.0	14.5	13.9	13.1	12.4	11.9	13.6	12.5				12.4					9.1				
20.0	13.2	12.7	12.1	11.6	11.2	12.5	11.7				11.5					9.1				
22.0	12.1	11.6	11.1	10.7	10.5	11.4	10.8	9.8			10.7	9.6				9.1				
24.0	11.1	10.7	10.3	10.0	9.7	10.5	10.0	9.2	8.5		9.9	9.0				9.1	8.3			
26.0	10.2	9.9	9.5	9.2	9.1	9.7	9.3	8.7	8.1	7.7	9.1	8.5	7.5			8.7	7.8			
28.0	7.6	8.6	8.7	8.5	8.3	9.0	8.6	8.2	7.7	7.4	8.5	8.0	7.1			8.2	7.4			
30.0	5.3	6.3	7.4	7.6	7.5	8.1	7.9	7.6	7.4	7.1	7.8	7.5	6.8			7.7	7.0			
32.0			5.2	5.8	6.0	6.1	7.1	6.9	6.7	6.6	7.1	6.9	6.4	6.0		7.2	6.6	5.9		
34.0							5.6	6.2	6.1	6.0	6.2	6.1	5.7	5.4		6.6	6.3	5.6		
36.0								5.4	5.5	5.4		5.6	5.5	5.4	5.2	5.9	5.8	5.3		
38.0									4.8	4.9			5.0	4.9	4.8	5.2	5.3	5.1	4.7	
40.0													4.5	4.4	4.4		4.8	4.7	4.5	
42.0														4.0	3.9			4.3	4.2	4.0
44.0																		3.9	3.9	3.7
46.0																			3.5	3.5
48.0																			3.1	3.1
θ (°)	64~ 84.5	65~ 84.5	64~ 84.5	66~ 84.5	66~ 84.5	65~ 84.5	66~ 84.5	67~ 84.5	67~ 84.5	68~ 84.5	67~ 84.5	69~ 84.5	69~ 84.5	70~ 84.5	72~ 84.5	67~ 84.5	70~ 84.5	72~ 84.5	72~ 84.5	75~ 84.5
標準フック	35t					35t					12.2t									
フック重量	950kg					950kg					440kg									
標準巻掛本数	2					2					1									

カウンタウエイト 58t、アウトリガ張出幅 8.0m
55.6mブーム+2.3m+フルオートラフィングジブ

単位:t

ジブ長さ(m) 作業半径 (m)	10.3m オフセット					17.2m オフセット					24.1m オフセット					31.0m オフセット				
	5°	15°	30°	45°	60°	5°	15°	30°	45°	60°	5°	15°	30°	45°	60°	5°	15°	30°	45°	60°
12.0	14.6																			
14.0	14.6	14.5																		
16.0	13.9	13.2				12.0														
18.0	12.5	12.1	11.2			11.6	10.7				9.4									
20.0	11.3	11.0	10.4	9.9	9.5	10.7	9.8				9.4					6.4				
22.0	10.3	10.0	9.6	9.2	8.9	9.8	9.1	8.3			9.3	8.5				6.4				
24.0	9.3	9.1	8.8	8.6	8.4	8.9	8.5	7.8			8.6	7.9				6.4				
26.0	8.1	8.0	7.8	7.7	7.5	8.0	7.9	7.3	6.9		8.0	7.4				6.4	6.4			
28.0	7.0	6.9	6.8	6.7	6.6	7.0	6.9	6.8	6.5	6.2	7.3	6.9	6.3			6.4	6.4			
30.0		6.0	6.0	5.9	5.8	6.1	6.1	6.1	6.0	5.9	6.5	6.5	5.9			6.4	6.0			
32.0				5.1	5.0	5.3	5.3	5.3	5.3	5.3	5.7	5.7	5.6			5.8	5.6			
34.0								4.7	4.7	4.6	5.0	5.1	5.1	4.9		5.1	5.2	4.9		
36.0									4.1	4.0		4.5	4.6	4.5	4.3	4.5	4.6	4.5		
38.0										3.5						4.1	4.1			
40.0																3.6	3.7	3.5		
42.0																3.1	3.1			
44.0																	2.9	2.9	2.8	
46.0																		2.6	2.6	
48.0																			2.3	
θ(°)	68~ 84.5	67~ 84.5	69~ 84.5	68~ 84.5	69~ 84.5	68~ 84.5	70~ 84.5	71~ 84.5	72~ 84.5	70~ 84.5	70~ 84.5	71~ 84.5	72~ 84.5	73~ 84.5	75~ 84.5	72~ 84.5	72~ 84.5	74~ 84.5	76~ 84.5	77~ 84.5
標準フック	35t					12.2t														
フック重量	950kg					440kg														
標準巻掛本数	2					1														

カウンタウエイト 58t、アウトリガ張出幅 8.0m
60.0mブーム+2.3m+フルオートラフィングジブ

単位:t

ジブ長さ(m) 作業半径 (m)	10.3m オフセット					17.2m オフセット					24.1m オフセット					31.0m オフセット				
	5°	15°	30°	45°	60°	5°	15°	30°	45°	60°	5°	15°	30°	45°	60°	5°	15°	30°	45°	60°
14.0	12.0																			
16.0	12.0	11.6				8.0														
18.0	11.0	10.6	9.9			8.0					7.1									
20.0	9.9	9.6	9.2	8.8		8.0	8.0				7.1					5.7				
22.0	8.9	8.7	8.5	8.1	7.9	8.0	8.0				7.1					5.7				
24.0	7.7	7.7	7.6	7.5	7.3	8.0	7.7	7.2			7.1	6.9				5.7				
26.0	6.7	6.6	6.6	6.5	6.4	7.1	7.1	6.7			7.1	6.6				5.7				
28.0	5.7	5.7	5.7	5.6	5.5	6.1	6.2	6.2	5.9		6.3	6.2				5.7				
30.0			4.8	4.8	4.7	5.3	5.4	5.4	5.4	5.4	5.5	5.6	5.3			5.6	5.2			
32.0							4.6	4.7	4.8	4.7	4.7	4.9	4.9			4.9	4.9			
34.0								4.1	4.1	4.1		4.2	4.4	4.2		4.3	4.4			
36.0									3.5	3.5			3.8	3.9		3.9	3.6			
38.0													3.3	3.4	3.4	3.4	3.3			
40.0														3.0	3.0		3.0			
42.0															2.5		2.7	2.6		
44.0																		2.4		
46.0																				2.2
θ(°)	70~ 84.5	71~ 84.5	71~ 84.5	72~ 84.5	73~ 84.5	72~ 84.5	72~ 84.5	73~ 84.5	74~ 84.5	75~ 84.5	73~ 84.5	74~ 84.5	75~ 84.5	76~ 84.5	77~ 84.5	74~ 84.5	75~ 84.5	77~ 84.5	79~ 84.5	80~ 84.5
標準フック	12.2t					440kg														
フック重量	440kg																			
標準巻掛本数	1																			

フルオートラフィングジブ

カウンタウエイト 58t、アウトリガ張出幅 6.8m
40.4mブーム+2.3m+フルオートラフィングジブ

単位:t

ジブ長さ(m) 作業半径 (m)	10.3m オフセット					17.2m オフセット					24.1m オフセット					31.0m オフセット				
	5°	15°	30°	45°	60°	5°	15°	30°	45°	60°	5°	15°	30°	45°	60°	5°	15°	30°	45°	60°
9.0	38.4																			
10.0	36.0					16.7														
11.0	33.8	31.6				16.7														
12.0	31.9	30.2				16.7														
14.0	28.6	27.3	25.2			16.7	16.7				16.0									
16.0	25.8	24.8	23.5	22.1	21.1	16.7	16.7				15.5					10.9				
18.0	21.7	22.6	21.6	20.9	20.3	16.7	16.7	16.7			15.0	13.5				10.8				
20.0	16.8	18.2	19.8	19.4	19.0	16.7	16.7	15.9			14.5	13.0				10.5				
22.0	12.6	13.9	15.7	16.7	17.3	15.9	16.7	15.2	14.0		13.9	12.5				10.3	9.2			
24.0	9.2	10.4	11.9	13.0	13.4	12.4	14.4	14.5	13.4	12.9	13.4	12.1	10.8			10.0	8.8			
26.0	6.4	7.4	8.7	9.6	9.9	9.5	11.3	13.5	13.0	12.5	11.8	11.7	10.5			9.7	8.4			
28.0			6.1	6.8	7.0	7.1	8.7	10.8	12.4	12.1	9.4	11.4	10.1	9.3		9.2	8.1			
30.0						5.1	6.5	8.3	9.8	10.6	7.3	9.2	9.8	9.0	8.5	8.8	7.8	6.7		
32.0							4.6	6.2	7.5	8.1	5.5	7.2	9.6	8.8	8.4	7.6	7.5	6.5		
34.0								4.4	5.4	5.8		5.5	7.7	8.6	8.3	6.0	7.2	6.2		
36.0													6.0	7.6	8.2	4.5	6.4	6.1	5.5	
38.0													4.4	5.8	6.6	5.0	5.9	5.3		
40.0														4.3	4.9		5.7	5.2	5.0	
42.0																	4.6	5.1	5.0	
44.0																		4.9	4.9	
46.0																			4.5	
θ (°)	62~ 84.5	64~ 84.5	63~ 84.5	64~ 84.5	64~ 84.5	63~ 84.5	63~ 84.5	64~ 84.5	67~ 84.5	68~ 84.5	64~ 84.5	66~ 84.5	66~ 84.5	67~ 84.5	69~ 84.5	64~ 84.5	67~ 84.5	69~ 84.5	71~ 84.5	72~ 84.5
標準フック	80t					35t					12.2t									
フック重量	1550kg					950kg					440kg									
標準巻掛本数	4					2					1									

カウンタウエイト 58t、アウトリガ張出幅 6.8m
45.4mブーム+2.3m+フルオートラフィングジブ

単位:t

ジブ長さ(m) 作業半径 (m)	10.3m オフセット					17.2m オフセット					24.1m オフセット					31.0m オフセット				
	5°	15°	30°	45°	60°	5°	15°	30°	45°	60°	5°	15°	30°	45°	60°	5°	15°	30°	45°	60°
10.0	29.5																			
11.0	27.8																			
12.0	26.3	24.5				16.7														
14.0	23.6	22.2	20.6			16.7					15.3									
16.0	21.4	20.3	19.0	18.0		16.7	16.7				14.8					10.4				
18.0	19.6	18.6	17.5	16.7	16.2	16.7	16.7				14.4					10.3				
20.0	16.9	17.2	16.2	15.6	15.1	16.4	15.4	14.3			14.0	12.8				10.1				
22.0	12.7	14.1	15.1	14.5	14.2	15.2	14.3	13.3			13.7	12.4				9.9	9.0			
24.0	9.3	10.5	12.1	13.3	13.3	12.2	13.3	12.5	11.9		13.0	12.0				9.6	8.7			
26.0	6.5	7.6	9.0	9.9	10.4	9.4	11.2	11.7	11.2	10.8	11.5	11.4	10.4			9.4	8.3			
28.0			6.3	7.1	7.4	6.9	8.6	10.8	10.5	10.2	9.1	10.7	9.9			9.2	8.0			
30.0							6.4	8.3	9.8	9.7	7.0	9.0	9.4	8.8		8.8	7.7	6.6		
32.0								6.2	7.5	8.2		7.0	8.9	8.5	8.2	7.2	7.4	6.4		
34.0									5.5	6.1		5.3	7.6	8.1	7.9	5.6	7.2	6.2		
36.0													5.9	7.5	7.5		6.1	6.0	5.5	
38.0														5.8	6.7			5.8	5.3	
40.0															5.0			5.7	5.2	5.0
42.0																			5.1	4.9
44.0																			4.9	4.8
θ (°)	65~ 84.5	67~ 84.5	66~ 84.5	68~ 84.5	68~ 84.5	68~ 84.5	68~ 84.5	69~ 84.5	69~ 84.5	70~ 84.5	69~ 84.5	69~ 84.5	72~ 84.5	74~ 84.5	73~ 84.5	68~ 84.5	71~ 84.5	73~ 84.5	74~ 84.5	76~ 84.5
標準フック	35t					35t					12.2t									
フック重量	950kg					950kg					440kg									
標準巻掛本数	3					2					1									

カウンタウエイト 58t、アウトリガ張出幅 6.8m
50.5mブーム+2.3m+フルオートラフィングジブ

単位:t

ジブ長さ(m) 作業半径 (m)	10.3m オフセット					17.2m オフセット					24.1m オフセット					31.0m オフセット				
	5°	15°	30°	45°	60°	5°	15°	30°	45°	60°	5°	15°	30°	45°	60°	5°	15°	30°	45°	60°
11.0	21.2																			
12.0	20.0																			
14.0	17.8	16.8				16.5														
16.0	16.0	15.2	14.2			15.0					13.5									
18.0	14.5	13.9	13.1	12.4	11.9	13.6	12.5				12.4					9.1				
20.0	13.2	12.7	12.1	11.6	11.2	12.5	11.7				11.5					9.1				
22.0	12.1	11.6	11.1	10.7	10.5	11.4	10.8	9.8			10.7	9.6				9.1				
24.0	9.4	10.7	10.3	10.0	9.7	10.5	10.0	9.2	8.5		9.9	9.0				9.1	8.3			
26.0	6.6	7.7	9.1	9.2	9.1	9.4	9.3	8.7	8.1	7.7	9.1	8.5	7.5			8.7	7.8			
28.0			6.5	7.4	7.8	7.0	8.6	8.2	7.7	7.4	8.5	8.0	7.1			8.2	7.4			
30.0							6.5	7.6	7.4	7.1	6.9	7.5	6.8			7.7	7.0			
32.0								6.4	6.7	6.6		6.9	6.4	6.0		7.1	6.6	5.9		
34.0									5.8	6.0			6.1	5.7	5.4		6.3	5.6		
36.0													5.5	5.4	5.2		5.8	5.3		
38.0														4.9	4.8				5.1	4.7
40.0																			4.7	4.5
42.0																				4.2
44.0																				3.7
θ(°)	67~ 84.5	69~ 84.5	69~ 84.5	70~ 84.5	70~ 84.5	69~ 84.5	70~ 84.5	71~ 84.5	71~ 84.5	72~ 84.5	70~ 84.5	72~ 84.5	73~ 84.5	74~ 84.5	76~ 84.5	72~ 84.5	73~ 84.5	75~ 84.5	78~ 84.5	79~ 84.5
標準フック																12.2t				
フック重量																440kg				
標準巻掛本数																1				

カウンタウエイト 58t、アウトリガ張出幅 6.8m
55.6mブーム+2.3m+フルオートラフィングジブ

単位:t

ジブ長さ(m) 作業半径 (m)	10.3m オフセット					17.2m オフセット					24.1m オフセット					31.0m オフセット				
	5°	15°	30°	45°	60°	5°	15°	30°	45°	60°	5°	15°	30°	45°	60°	5°	15°	30°	45°	60°
12.0	14.6																			
14.0	14.6	14.5																		
16.0	13.9	13.2				12.0														
18.0	12.5	12.1	11.2			11.6	10.7				9.4									
20.0	11.3	11.0	10.4	9.9	9.5	10.7	9.8				9.4					6.4				
22.0	10.3	10.0	9.6	9.2	8.9	9.8	9.1	8.3			9.3	8.5				6.4				
24.0	9.3	9.1	8.8	8.6	8.4	8.9	8.5	7.8			8.6	7.9				6.4				
26.0		8.0	7.8	7.7	7.5	8.0	7.9	7.3	6.9		8.0	7.4				6.4	6.4			
28.0				6.7	6.6		6.9	6.8	6.5	6.2	7.3	6.9	6.3			6.4	6.4			
30.0								6.1	6.0	5.9	6.5	6.5	5.9			6.4	6.0			
32.0									5.3	5.3		5.7	5.6				5.6			
34.0										4.6			5.1	4.9			5.2	4.9		
36.0													4.5	4.3				4.5		
38.0													4.1	4.0				4.1		
40.0																				3.5
42.0																				3.2
44.0																				2.8
θ(°)	71~ 84.5	71~ 84.5	73~ 84.5	72~ 84.5	73~ 84.5	72~ 84.5	74~ 84.5	75~ 84.5	75~ 84.5	75~ 84.5	73~ 84.5	74~ 84.5	77~ 84.5	77~ 84.5	79~ 84.5	76~ 84.5	76~ 84.5	78~ 84.5	79~ 84.5	81~ 84.5
標準フック																12.2t				
フック重量																440kg				
標準巻掛本数																1				

カウンタウエイト 58t、アウトリガ張出幅 6.8m
60.0mブーム+2.3m+フルオートラフィングジブ

単位:t

ジブ長さ(m) 作業半径 (m)	10.3m オフセット					17.2m オフセット					24.1m オフセット					31.0m オフセット					
	5°	15°	30°	45°	60°	5°	15°	30°	45°	60°	5°	15°	30°	45°	60°	5°	15°	30°			
14.0	12.0																				
16.0	12.0	11.6				8.0															
18.0	11.0	10.6	9.9			8.0					7.1										
20.0	9.9	9.6	9.2	8.8		8.0	8.0				7.1					5.7					
22.0	8.9	8.7	8.5	8.1	7.9	8.0	8.0				7.1					5.7					
24.0	7.7	7.7	7.6	7.5	7.3	8.0	7.7	7.2			7.1	6.9				5.7					
26.0			6.6	6.5	6.4	7.1	7.1	6.7			7.1	6.6				5.7					
28.0					5.5		6.2	6.2	5.9		6.3	6.2				5.7					
30.0								5.4	5.4	5.4		5.6	5.3			5.6	5.2				
32.0									4.8	4.7			4.9				4.9				
34.0													4.4	4.2							
36.0														3.9					3.6		
38.0																					
θ(°)	73~ 84.5	75~ 84.5	75~ 84.5	76~ 84.5	75~ 84.5	75~ 84.5	75~ 84.5	77~ 84.5	77~ 84.5	78~ 84.5	76~ 84.5	77~ 84.5	78~ 84.5	80~ 84.5	80~ 84.5	77~ 84.5	79~ 84.5	81~ 84.5			
標準フック																			12.2t		
フック重量																			440kg		
標準巻掛本数																			1		

フルオートラフィングジブ

カウンタウエイト 47t、アウトリガ張出幅 8.5m
40.4mブーム+2.3m+フルオートラフィングジブ

単位:t

ジブ長さ(m) 作業半径 (m)	10.3m オフセット					17.2m オフセット					24.1m オフセット					31.0m オフセット				
	5°	15°	30°	45°	60°	5°	15°	30°	45°	60°	5°	15°	30°	45°	60°	5°	15°	30°	45°	60°
9.0	38.4																			
10.0	36.0					16.7														
11.0	33.8	31.6				16.7														
12.0	31.9	30.2				16.7														
14.0	28.6	27.3	25.2			16.7	16.7				16.0									
16.0	25.8	24.8	23.5	22.1	21.1	16.7	16.7				15.5					10.9				
18.0	23.5	22.6	21.6	20.9	20.3	16.7	16.7	16.7			15.0	13.5				10.8				
20.0	19.3	20.6	19.9	19.4	19.0	16.7	16.7	15.9			14.5	13.0				10.5				
22.0	14.7	16.2	17.7	18.0	17.7	16.7	16.7	15.2	14.0		13.9	12.5				10.3	9.2			
24.0	11.0	12.2	13.8	14.9	15.3	14.4	16.1	14.5	13.4	12.9	13.4	12.1	10.8			10.0	8.8			
26.0	7.9	9.0	10.4	11.3	11.6	11.2	13.0	13.9	13.0	12.5	12.9	11.7	10.5			9.7	8.4			
28.0	5.4	6.3	7.5	8.2	8.4	8.6	10.2	12.4	12.5	12.1	10.9	11.4	10.1	9.3		9.2	8.1			
30.0			5.0	5.6		6.3	7.8	9.7	11.2	11.8	8.6	10.6	9.8	9.0	8.5	8.8	7.8	6.7		
32.0						4.4	5.7	7.4	8.7	9.3	6.6	8.5	9.6	8.8	8.4	8.5	7.5	6.5		
34.0								5.4	6.5	7.0	5.0	6.6	8.8	8.6	8.3	7.1	7.2	6.2		
36.0									4.6	4.9		5.0	7.0	8.5	8.2	5.6	6.9	6.1	5.5	
38.0													5.4	6.8	7.6	4.2	5.9	5.9	5.3	
40.0													3.9	5.2	5.8	4.6	5.7	5.2	5.0	
42.0																	5.5	5.1	5.0	
44.0																	4.2	5.0	4.9	
46.0																		4.4	4.8	
θ (°)	59~ 84.5	61~ 84.5	60~ 84.5	62~ 84.5	64~ 84.5	61~ 84.5	63~ 84.5	64~ 84.5	64~ 84.5	65~ 84.5	62~ 84.5	64~ 84.5	64~ 84.5	67~ 84.5	69~ 84.5	62~ 84.5	65~ 84.5	67~ 84.5	69~ 84.5	72~ 84.5
標準フック											35t					12.2t				
フック重量	1550kg										950kg					440kg				
標準巻掛本数	4										2					1				

カウンタウエイト 47t、アウトリガ張出幅 8.5m
45.4mブーム+2.3m+フルオートラフィングジブ

単位:t

ジブ長さ(m) 作業半径 (m)	10.3m オフセット					17.2m オフセット					24.1m オフセット					31.0m オフセット				
	5°	15°	30°	45°	60°	5°	15°	30°	45°	60°	5°	15°	30°	45°	60°	5°	15°	30°	45°	60°
10.0	29.5																			
11.0	27.8																			
12.0	26.3	24.5				16.7														
14.0	23.6	22.2	20.6			16.7					15.3									
16.0	21.4	20.3	19.0	18.0		16.7	16.7				14.8					10.4				
18.0	19.6	18.6	17.5	16.7	16.2	16.7	16.7				14.4					10.3				
20.0	18.0	17.2	16.2	15.6	15.1	16.4	15.4	14.3			14.0	12.8				10.1				
22.0	14.9	15.9	15.1	14.5	14.2	15.2	14.3	13.3			13.7	12.4				9.9	9.0			
24.0	11.1	12.4	14.0	13.6	13.3	14.1	13.3	12.5	11.9		13.0	12.0				9.6	8.7			
26.0	8.0	9.2	10.6	11.6	12.0	11.0	12.4	11.7	11.2	10.8	12.1	11.4	10.4			9.4	8.3			
28.0		6.5	7.7	8.6	8.9	8.4	10.1	11.0	10.5	10.2	10.6	10.7	9.9			9.2	8.0			
30.0			5.3	6.0	6.2	6.1	7.7	9.7	9.9	9.7	8.3	10.0	9.4	8.8		8.8	7.7	6.6		
32.0							5.6	7.4	8.8	9.2	6.3	8.2	8.9	8.5	8.2	8.4	7.4	6.4		
34.0								5.4	6.6	7.2		6.4	8.4	8.1	7.9	6.7	7.2	6.2		
36.0													6.9	7.7	7.5	5.2	6.9	6.0	5.5	
38.0													5.3	6.8	7.0		5.7	5.8	5.3	
40.0														5.2	5.9			5.7	5.2	5.0
42.0																	5.3	5.1	4.9	
44.0																		5.0	4.8	
46.0																			4.8	
θ (°)	65~ 84.5	64~ 84.5	64~ 84.5	65~ 84.5	66~ 84.5	66~ 84.5	66~ 84.5	67~ 84.5	69~ 84.5	67~ 84.5	67~ 84.5	69~ 84.5	70~ 84.5	71~ 84.5	73~ 84.5	66~ 84.5	69~ 84.5	72~ 84.5	74~ 84.5	74~ 84.5
標準フック											35t					12.2t				
フック重量	950kg										950kg					440kg				
標準巻掛本数	3										2					1				

カウンタウエイト 47t、アウトリガ張出幅 8.5m
50.5mブーム+2.3m+フルオートラフィングジブ

単位:t

ジブ長さ(m) 作業半径	10.3m オフセット					17.2m オフセット					24.1m オフセット					31.0m オフセット				
	5°	15°	30°	45°	60°	5°	15°	30°	45°	60°	5°	15°	30°	45°	60°	5°	15°	30°	45°	60°
11.0	21.2																			
12.0	20.0																			
14.0	17.8	16.8				16.5														
16.0	16.0	15.2	14.2			15.0					13.5									
18.0	14.5	13.9	13.1	12.4	11.9	13.6	12.5				12.4					9.1				
20.0	13.2	12.7	12.1	11.6	11.2	12.5	11.7				11.5					9.1				
22.0	12.1	11.6	11.1	10.7	10.5	11.4	10.8	9.8			10.7	9.6				9.1				
24.0	11.1	10.7	10.3	10.0	9.7	10.5	10.0	9.2	8.5		9.9	9.0				9.1	8.3			
26.0	8.2	9.3	9.5	9.2	9.1	9.7	9.3	8.7	8.1	7.7	9.1	8.5	7.5			8.7	7.8			
28.0		6.6	7.9	8.5	8.3	8.5	8.6	8.2	7.7	7.4	8.5	8.0	7.1			8.2	7.4			
30.0				6.3	6.6		7.8	7.6	7.4	7.1	7.8	7.5	6.8			7.7	7.0			
32.0								6.9	6.7	6.6	6.3	6.9	6.4	6.0		7.2	6.6	5.9		
34.0									6.1	6.0		6.2	6.1	5.7	5.4	6.6	6.3	5.6		
36.0										5.4			5.5	5.4	5.2		5.8	5.3		
38.0														4.9	4.8		5.3	5.1	4.7	
40.0														4.4	4.4			4.7	4.5	
42.0																	4.3	4.2	4.0	
44.0																		3.9	3.7	
46.0																			3.5	
θ(°)	67~ 84.5	67~ 84.5	69~ 84.5	68~ 84.5	68~ 84.5	69~ 84.5	70~ 84.5	71~ 84.5	71~ 84.5	70~ 84.5	69~ 84.5	70~ 84.5	73~ 84.5	72~ 84.5	74~ 84.5	70~ 84.5	72~ 84.5	73~ 84.5	76~ 84.5	77~ 84.5
標準フック	35t										12.2t					12.2t				
フック重量	950kg										440kg					440kg				
標準巻掛本数	2										1					1				

カウンタウエイト 47t、アウトリガ張出幅 8.5m
55.6mブーム+2.3m+フルオートラフィングジブ

単位:t

ジブ長さ(m) 作業半径	10.3m オフセット					17.2m オフセット					24.1m オフセット					31.0m オフセット				
	5°	15°	30°	45°	60°	5°	15°	30°	45°	60°	5°	15°	30°	45°	60°	5°	15°	30°	45°	60°
12.0	14.6																			
14.0	14.6	14.5																		
16.0	13.9	13.2				12.0														
18.0	12.5	12.1	11.2			11.6	10.7				9.4									
20.0	11.3	11.0	10.4	9.9	9.5	10.7	9.8				9.4					6.4				
22.0	10.3	10.0	9.6	9.2	8.9	9.8	9.1	8.3			9.3	8.5				6.4				
24.0	9.3	9.1	8.8	8.6	8.4	8.9	8.5	7.8			8.6	7.9				6.4				
26.0	8.1	8.0	7.8	7.7	7.5	8.0	7.9	7.3	6.9		8.0	7.4				6.4	6.4			
28.0			6.8	6.7	6.6	7.0	6.9	6.8	6.5	6.2	7.3	6.9	6.3			6.4	6.4			
30.0				5.9	5.8		6.1	6.1	6.0	5.9	6.5	6.5	5.9			6.4	6.0			
32.0								5.3	5.3	5.3		5.7	5.6			5.8	5.6			
34.0									4.7	4.6		5.1	5.1	4.9			5.2	4.9		
36.0												4.6	4.5	4.3			4.6	4.5		
38.0													4.1	4.0			4.1			
40.0														3.6			3.7	3.5		
42.0																		3.2		
44.0																				2.8
θ(°)	70~ 84.5	71~ 84.5	71~ 84.5	70~ 84.5	71~ 84.5	71~ 84.5	72~ 84.5	73~ 84.5	73~ 84.5	75~ 84.5	73~ 84.5	73~ 84.5	75~ 84.5	77~ 84.5	77~ 84.5	74~ 84.5	75~ 84.5	77~ 84.5	79~ 84.5	81~ 84.5
標準フック	35t										12.2t					12.2t				
フック重量	950kg										440kg					440kg				
標準巻掛本数	2										1					1				

カウンタウエイト 47t、アウトリガ張出幅 8.5m
60.0mブーム+2.3m+フルオートラフィングジブ

単位:t

ジブ長さ(m) 作業半径	10.3m オフセット					17.2m オフセット					24.1m オフセット					31.0m オフセット				
	5°	15°	30°	45°	60°	5°	15°	30°	45°	60°	5°	15°	30°	45°	60°	5°	15°	30°	45°	
14.0	12.0					8.0														
16.0	12.0	11.6				8.0					7.1									
18.0	11.0	10.6	9.9			8.0					7.1									
20.0	9.9	9.6	9.2	8.8		8.0	8.0				7.1									
22.0	8.9	8.7	8.5	8.1	7.9	8.0	8.0				7.1									
24.0	7.7	7.7	7.6	7.5	7.3	8.0	7.7	7.2			7.1	6.9								
26.0		6.6	6.6	6.5	6.4	7.1	7.1	6.7			7.1	6.6								
28.0				5.6	5.5	6.1	6.2	6.2	5.9		6.3	6.2								
30.0								5.4	5.4	5.4		5.6	5.3				5.6	5.2		
32.0								4.7	4.8	4.7		4.9	4.9				4.9			
34.0									4.1	4.1			4.4	4.2			4.4			
36.0													3.9							
38.0													3.4	3.4						
40.0																				
42.0																				2.6
θ(°)	73~ 84.5	73~ 84.5	75~ 84.5	74~ 84.5	75~ 84.5	74~ 84.5	75~ 84.5	75~ 84.5	75~ 84.5	77~ 84.5	76~ 84.5	75~ 84.5	78~ 84.5	78~ 84.5	80~ 84.5	77~ 84.5	78~ 84.5	80~ 84.5	81~ 84.5	
標準フック	12.2t										12.2t				12.2t					
フック重量	440kg										440kg				440kg					
標準巻掛本数	1										1				1					

フルオートラフィングジブ

カウンタウエイト 47t、アウトリガ張出幅 8.0m
40.4mブーム+2.3m+フルオートラフィングジブ

単位:t

ジブ長さ(m) 作業半径 (m)	10.3m オフセット					17.2m オフセット					24.1m オフセット					31.0m オフセット				
	5°	15°	30°	45°	60°	5°	15°	30°	45°	60°	5°	15°	30°	45°	60°	5°	15°	30°	45°	60°
9.0	38.4																			
10.0	36.0					16.7														
11.0	33.8	31.6				16.7														
12.0	31.9	30.2				16.7														
14.0	28.6	27.3	25.2			16.7	16.7				16.0									
16.0	25.8	24.8	23.5	22.1	21.1	16.7	16.7				15.5					10.9				
18.0	22.3	22.6	21.6	20.9	20.3	16.7	16.7	16.7			15.0	13.5				10.8				
20.0	17.3	18.6	19.9	19.4	19.0	16.7	16.7	15.9			14.5	13.0				10.5				
22.0	12.9	14.3	16.0	17.1	17.6	16.2	16.7	15.2	14.0		13.9	12.5				10.3	9.2			
24.0	9.3	10.6	12.1	13.2	13.7	12.7	14.6	14.5	13.4	12.9	13.4	12.1	10.8			10.0	8.8			
26.0	6.5	7.5	8.9	9.8	10.1	9.7	11.5	13.7	13.0	12.5	12.0	11.7	10.5			9.7	8.4			
28.0			6.2	6.9	7.1	7.2	8.8	11.0	12.5	12.1	9.5	11.4	10.1	9.3		9.2	8.1			
30.0						5.1	6.6	8.5	9.9	10.7	7.4	9.3	9.8	9.0	8.5	8.8	7.8	6.7		
32.0							4.6	6.3	7.5	8.2	5.5	7.3	9.6	8.8	8.4	7.6	7.5	6.5		
34.0								4.4	5.5	5.9		5.5	7.8	8.6	8.3	6.0	7.2	6.2		
36.0													6.0	7.6	8.2	4.6	6.4	6.1	5.5	
38.0													4.5	5.9	6.7	5.0	5.9	5.3		
40.0														4.3	4.9		5.7	5.2	5.0	
42.0																	4.6	5.1	5.0	
44.0																		5.0	4.9	
46.0																			4.5	
θ(°)	62~ 84.5	64~ 84.5	63~ 84.5	64~ 84.5	64~ 84.5	63~ 84.5	63~ 84.5	64~ 84.5	67~ 84.5	68~ 84.5	64~ 84.5	66~ 84.5	66~ 84.5	67~ 84.5	69~ 84.5	64~ 84.5	67~ 84.5	69~ 84.5	71~ 84.5	72~ 84.5
標準フック	80t					35t					12.2t									
フック重量	1550kg					950kg					440kg									
標準巻掛本数	4					2					1									

カウンタウエイト 47t、アウトリガ張出幅 8.0m
45.4mブーム+2.3m+フルオートラフィングジブ

単位:t

ジブ長さ(m) 作業半径 (m)	10.3m オフセット					17.2m オフセット					24.1m オフセット					31.0m オフセット				
	5°	15°	30°	45°	60°	5°	15°	30°	45°	60°	5°	15°	30°	45°	60°	5°	15°	30°	45°	60°
10.0	29.5																			
11.0	27.8																			
12.0	26.3	24.5				16.7														
14.0	23.6	22.2	20.6			16.7					15.3									
16.0	21.4	20.3	19.0	18.0		16.7	16.7				14.8					10.4				
18.0	19.6	18.6	17.5	16.7	16.2	16.7	16.7				14.4					10.3				
20.0	17.4	17.2	16.2	15.6	15.1	16.4	15.4	14.3			14.0	12.8				10.1				
22.0	13.0	14.5	15.1	14.5	14.2	15.2	14.3	13.3			13.7	12.4				9.9	9.0			
24.0	9.5	10.8	12.4	13.5	13.3	12.5	13.3	12.5	11.9		13.0	12.0				9.6	8.7			
26.0	6.6	7.7	9.1	10.1	10.5	9.5	11.4	11.7	11.2	10.8	11.7	11.4	10.4			9.4	8.3			
28.0			6.4	7.2	7.5	7.0	8.7	10.9	10.5	10.2	9.2	10.7	9.9			9.2	8.0			
30.0							6.4	8.4	9.9	9.7	7.1	9.1	9.4	8.8		8.8	7.7	6.6		
32.0								6.3	7.6	8.3		7.1	8.9	8.5	8.2	7.3	7.4	6.4		
34.0									5.5	6.1			7.6	8.1	7.9	5.7	7.2	6.2		
36.0													5.9	7.6	7.5		6.2	6.0	5.5	
38.0														5.9	6.8		5.8	5.3		
40.0															5.1		5.7	5.2	5.0	
42.0																		5.1	4.9	
44.0																			4.9	4.8
θ(°)	65~ 84.5	67~ 84.5	66~ 84.5	68~ 84.5	68~ 84.5	68~ 84.5	68~ 84.5	69~ 84.5	69~ 84.5	70~ 84.5	69~ 84.5	71~ 84.5	72~ 84.5	74~ 84.5	73~ 84.5	68~ 84.5	71~ 84.5	73~ 84.5	74~ 84.5	76~ 84.5
標準フック	35t					35t					12.2t									
フック重量	950kg					950kg					440kg									
標準巻掛本数	3					2					1									

カウンタウエイト 47t、アウトリガ張出幅 8.0m
50.5mブーム+2.3m+フルオートラフィングジブ

単位:t

ジブ長さ(m) 作業半径 (m)	10.3m オフセット					17.2m オフセット					24.1m オフセット					31.0m オフセット				
	5°	15°	30°	45°	60°	5°	15°	30°	45°	60°	5°	15°	30°	45°	60°	5°	15°	30°	45°	60°
11.0	21.2																			
12.0	20.0																			
14.0	17.8	16.8				16.5														
16.0	16.0	15.2	14.2			15.0					13.5									
18.0	14.5	13.9	13.1	12.4	11.9	13.6	12.5				12.4					9.1				
20.0	13.2	12.7	12.1	11.6	11.2	12.5	11.7				11.5					9.1				
22.0	12.1	11.6	11.1	10.7	10.5	11.4	10.8	9.8			10.7	9.6				9.1				
24.0	9.6	10.7	10.3	10.0	9.7	10.5	10.0	9.2	8.5		9.9	9.0				9.1	8.3			
26.0		7.8	9.3	9.2	9.1	9.6	9.3	8.7	8.1	7.7	9.1	8.5	7.5			8.7	7.8			
28.0			6.6	7.5	7.9	7.1	8.6	8.2	7.7	7.4	8.5	8.0	7.1			8.2	7.4			
30.0								7.6	7.4	7.1	7.0	7.5	6.8			7.7	7.0			
32.0								6.4	6.7	6.6		6.9	6.4	6.0		7.2	6.6	5.9		
34.0										6.0			6.1	5.7	5.4		6.3	5.6		
36.0													5.5	5.4	5.2		5.8	5.3		
38.0														4.9	4.8				5.1	4.7
40.0																			4.7	4.5
42.0																				4.2
44.0																				3.7
θ(°)	69~ 84.5	69~ 84.5	69~ 84.5	70~ 84.5	70~ 84.5	69~ 84.5	72~ 84.5	71~ 84.5	73~ 84.5	72~ 84.5	70~ 84.5	72~ 84.5	73~ 84.5	74~ 84.5	76~ 84.5	72~ 84.5	73~ 84.5	75~ 84.5	78~ 84.5	79~ 84.5
標準フック																12.2t				
フック重量																440kg				
標準巻掛本数																1				

カウンタウエイト 47t、アウトリガ張出幅 8.0m
55.6mブーム+2.3m+フルオートラフィングジブ

単位:t

ジブ長さ(m) 作業半径 (m)	10.3m オフセット					17.2m オフセット					24.1m オフセット					31.0m オフセット				
	5°	15°	30°	45°	60°	5°	15°	30°	45°	60°	5°	15°	30°	45°	60°	5°	15°	30°	45°	
12.0	14.6																			
14.0	14.6	14.5																		
16.0	13.9	13.2				12.0														
18.0	12.5	12.1	11.2			11.6	10.7				9.4									
20.0	11.3	11.0	10.4	9.9	9.5	10.7	9.8				9.4					6.4				
22.0	10.3	10.0	9.6	9.2	8.9	9.8	9.1	8.3			9.3	8.5				6.4				
24.0	9.3	9.1	8.8	8.6	8.4	8.9	8.5	7.8			8.6	7.9				6.4				
26.0		8.0	7.8	7.7	7.5	8.0	7.9	7.3	6.9		8.0	7.4				6.4	6.4			
28.0				6.7	6.6		6.9	6.8	6.5	6.2	7.3	6.9	6.3			6.4	6.4			
30.0								6.1	6.0	5.9		6.5	5.9			6.4	6.0			
32.0									5.3	5.3		5.7	5.6			5.6				
34.0										4.6			5.1	4.9		5.2	4.9			
36.0														4.5	4.3				4.5	
38.0														4.1	4.0				4.1	
40.0																				3.5
42.0																				3.2
θ(°)	71~ 84.5	71~ 84.5	73~ 84.5	72~ 84.5	73~ 84.5	72~ 84.5	74~ 84.5	75~ 84.5	75~ 84.5	75~ 84.5	74~ 84.5	74~ 84.5	77~ 84.5	77~ 84.5	79~ 84.5	76~ 84.5	76~ 84.5	78~ 84.5	79~ 84.5	
標準フック																12.2t				
フック重量																440kg				
標準巻掛本数																1				

カウンタウエイト 47t、アウトリガ張出幅 8.0m
60.0mブーム+2.3m+フルオートラフィングジブ

単位:t

ジブ長さ(m) 作業半径 (m)	10.3m オフセット					17.2m オフセット					24.1m オフセット					31.0m オフセット			
	5°	15°	30°	45°	60°	5°	15°	30°	45°	60°	5°	15°	30°	45°	60°	5°	15°	30°	
14.0	12.0					8.0													
16.0	12.0	11.6				8.0					7.1								
18.0	11.0	10.6	9.9			8.0					7.1								
20.0	9.9	9.6	9.2	8.8		8.0	8.0				7.1					5.7			
22.0	8.9	8.7	8.5	8.1	7.9	8.0	8.0				7.1					5.7			
24.0		7.7	7.6	7.5	7.3	8.0	7.7	7.2			7.1	6.9				5.7			
26.0			6.6	6.5	6.4	7.1	7.1	6.7			7.1	6.6				5.7			
28.0							6.2	6.2	5.9		6.3	6.2				5.7			
30.0								5.4	5.4	5.4		5.6	5.3				5.2		
32.0									4.8	4.7			4.9				4.9		
34.0													4.4	4.2					
36.0														3.9					3.6
38.0																3.4			
θ(°)	75~ 84.5	75~ 84.5	75~ 84.5	76~ 84.5	77~ 84.5	75~ 84.5	75~ 84.5	77~ 84.5	77~ 84.5	78~ 84.5	76~ 84.5	77~ 84.5	78~ 84.5	80~ 84.5	80~ 84.5	78~ 84.5	79~ 84.5	81~ 84.5	
標準フック																12.2t			
フック重量																440kg			
標準巻掛本数																1			

フルオートラフィングジブ

カウンタウエイト 47t、アウトリガ張出幅 6.8m
40.4mブーム+2.3m+フルオートラフィングジブ

単位:t

ジブ長さ(m) 作業半径 (m)	10.3m オフセット					17.2m オフセット					24.1m オフセット					31.0m オフセット				
	5°	15°	30°	45°	60°	5°	15°	30°	45°	60°	5°	15°	30°	45°	60°	5°	15°	30°	45°	60°
9.0	38.4																			
10.0	36.0					16.7														
11.0	33.8	31.6				16.7														
12.0	31.9	30.2				16.7														
14.0	28.6	27.3	25.2			16.7	16.7				16.0									
16.0	22.7	24.4	23.5	22.1	21.1	16.7	16.7				15.5					10.9				
18.0	17.1	18.6	20.5	20.9	20.3	16.7	16.7	16.7			15.0	13.5				10.8				
20.0	12.3	13.9	15.8	17.1	17.8	15.7	16.7	15.9			14.5	13.0				10.5				
22.0	8.6	9.9	11.7	13.0	13.7	11.9	14.1	15.2	14.0		13.9	12.5				10.3	9.2			
24.0			8.3	9.4	9.8	8.8	10.8	13.3	13.4	12.9	11.2	12.1	10.8			10.0	8.8			
26.0					6.7	6.3	8.0	10.4	12.1	12.5	8.5	10.9	10.5			9.7	8.4			
28.0								7.8	9.4	10.4	6.3	8.5	10.1	9.3		8.5	8.1			
30.0								5.6	7.0	7.8		6.4	9.1	9.0	8.5	6.6	7.8	6.7		
32.0										5.5			7.0	8.8	8.4		6.5	6.5		
34.0													5.3	7.1	8.3		5.5	6.2		
36.0														5.3	6.3		6.1	5.5		
38.0																	5.2	5.3		
40.0																	5.2	5.0		
42.0																		5.0		
θ (°)	67~ 84.5	69~ 84.5	69~ 84.5	70~ 84.5	68~ 84.5	68~ 84.5	70~ 84.5	69~ 84.5	72~ 84.5	70~ 84.5	68~ 84.5	70~ 84.5	71~ 84.5	72~ 84.5	74~ 84.5	70~ 84.5	71~ 84.5	73~ 84.5	76~ 84.5	77~ 84.5
標準フック	80t					35t					12.2t									
フック重量	1550kg					950kg					440kg									
標準巻掛本数	4					2					1									

カウンタウエイト 47t、アウトリガ張出幅 6.8m
45.4mブーム+2.3m+フルオートラフィングジブ

単位:t

ジブ長さ(m) 作業半径 (m)	10.3m オフセット					17.2m オフセット					24.1m オフセット					31.0m オフセット				
	5°	15°	30°	45°	60°	5°	15°	30°	45°	60°	5°	15°	30°	45°	60°	5°	15°	30°	45°	60°
10.0	29.5																			
11.0	27.8																			
12.0	26.3	24.5				16.7														
14.0	23.6	22.2	20.6			16.7					15.3									
16.0	21.4	20.3	19.0	18.0		16.7	16.7				14.8					10.4				
18.0	17.2	18.6	17.5	16.7	16.2	16.7	16.7				14.4					10.3				
20.0	12.5	14.1	16.0	15.6	15.1	15.6	15.4	14.3			14.0	12.8				10.1				
22.0	8.7	10.1	11.9	13.3	14.0	11.7	14.0	13.3			13.7	12.4				9.9	9.0			
24.0			8.5	9.7	10.2	8.6	10.7	12.5	11.9		10.8	12.0				9.6	8.7			
26.0					7.1		7.9	10.3	11.2	10.8	8.2	10.7	10.4			9.4	8.3			
28.0								7.7	9.5	10.2		8.3	9.9			8.2	8.0			
30.0									7.0	7.9			9.0	8.8		7.7	6.6			
32.0													6.9	8.5	8.2	6.9	6.4			
34.0														7.0	7.9		6.2			
36.0															6.4		6.0	5.5		
38.0																	5.3			
40.0																	5.2	5.0		
42.0																		4.9		
θ (°)	70~ 84.5	71~ 84.5	71~ 84.5	73~ 84.5	71~ 84.5	72~ 84.5	72~ 84.5	73~ 84.5	74~ 84.5	75~ 84.5	72~ 84.5	75~ 84.5	76~ 84.5	78~ 84.5	78~ 84.5	73~ 84.5	74~ 84.5	77~ 84.5	78~ 84.5	79~ 84.5
標準フック	35t					35t					12.2t									
フック重量	950kg					950kg					440kg									
標準巻掛本数	3					2					1									

カウンタウエイト 47t、アウトリガ張出幅 6.8m
50.5mブーム+2.3m+フルオートラフティングジブ

単位:t

ジブ長さ(m) 作業半径 (m)	10.3m オフセット					17.2m オフセット					24.1m オフセット					31.0m オフセット			
	5°	15°	30°	45°	60°	5°	15°	30°	45°	60°	5°	15°	30°	45°	60°	5°	15°	30°	45°
11.0	21.2																		
12.0	20.0																		
14.0	17.8	16.8				16.5													
16.0	16.0	15.2	14.2			15.0					13.5								
18.0	14.5	13.9	13.1	12.4	11.9	13.6	12.5				12.4					9.1			
20.0	12.5	12.7	12.1	11.6	11.2	12.5	11.7				11.5					9.1			
22.0		10.2	11.1	10.7	10.5	11.4	10.8	9.8			10.7	9.6				9.1			
24.0			8.7	9.9	9.7		10.0	9.2	8.5		9.9	9.0				9.1	8.3		
26.0								8.7	8.1	7.7		8.5	7.5			8.7	7.8		
28.0								7.9	7.7	7.4		8.0	7.1			8.1	7.4		
30.0									7.2	7.1			6.8				7.0		
32.0															6.0				5.9
34.0															5.7	5.4			5.6
36.0																5.2			
38.0																			4.7
θ(°)	73~ 84.5	73~ 84.5	73~ 84.5	74~ 84.5	75~ 84.5	74~ 84.5	75~ 84.5	75~ 84.5	75~ 84.5	77~ 84.5	75~ 84.5	76~ 84.5	78~ 84.5	78~ 84.5	78~ 84.5	74~ 84.5	78~ 84.5	80~ 84.5	81~ 84.5
標準フック																12.2t			
フック重量																440kg			
標準巻掛本数																1			

カウンタウエイト 47t、アウトリガ張出幅 6.8m
55.6mブーム+2.3m+フルオートラフティングジブ

単位:t

ジブ長さ(m) 作業半径 (m)	10.3m オフセット					17.2m オフセット					24.1m オフセット				31.0m オフセット			
	5°	15°	30°	45°	60°	5°	15°	30°	45°	60°	5°	15°	30°	45°	5°	15°	30°	
12.0	14.6																	
14.0	14.6	14.5																
16.0	13.9	13.2				12.0												
18.0	12.5	12.1	11.2			11.6	10.7				9.4							
20.0	11.3	11.0	10.4	9.9	9.5	10.7	9.8				9.4				6.4			
22.0		10.0	9.6	9.2	8.9	9.8	9.1	8.3			9.3	8.5			6.4			
24.0				8.6	8.4		8.5	7.8			8.6	7.9			6.4			
26.0								7.3	6.9			7.4			6.4	6.4		
28.0									6.5	6.2		6.9	6.3			6.4		
30.0										5.9			5.9			6.0		
32.0																		
34.0															4.9		4.9	
θ(°)	75~ 84.5	75~ 84.5	77~ 84.5	76~ 84.5	77~ 84.5	76~ 84.5	77~ 84.5	78~ 84.5	79~ 84.5	78~ 84.5	77~ 84.5	77~ 84.5	80~ 84.5	80~ 84.5	78~ 84.5	79~ 84.5	81~ 84.5	
標準フック																12.2t		
フック重量																440kg		
標準巻掛本数																1		

カウンタウエイト 47t、アウトリガ張出幅 6.8m
60.0mブーム+2.3m+フルオートラフティングジブ

単位:t

ジブ長さ(m) 作業半径 (m)	10.3m オフセット					17.2m オフセット				24.1m オフセット			31.0m オフセット	
	5°	15°	30°	45°	60°	5°	15°	30°	45°	5°	15°	30°	5°	
14.0	12.0													
16.0	12.0	11.6				8.0								
18.0	11.0	10.6	9.9			8.0				7.1				
20.0	9.9	9.6	9.2	8.8		8.0	8.0			7.1			5.7	
22.0			8.5	8.1	7.9	8.0	8.0			7.1			5.7	
24.0					7.3		7.7	7.2			6.9		5.7	
26.0								6.7			6.6			
28.0									5.9					
30.0												5.3		
θ(°)	77~ 84.5	78~ 84.5	78~ 84.5	80~ 84.5	78~ 84.5	78~ 84.5	80~ 84.5	80~ 84.5	80~ 84.5	80~ 84.5	81~ 84.5	81~ 84.5		
標準フック														12.2t
フック重量														440kg
標準巻掛本数														1

フルオートラフィングジブ

カウンタウエイト 25t、アウトリガ張出幅 8.5m
40.4mブーム+2.3m+フルオートラフィングジブ

単位:t

ジブ長さ(m) 作業半径 (m)	10.3m オフセット					17.2m オフセット					24.1m オフセット					31.0m オフセット			
	5°	15°	30°	45°	60°	5°	15°	30°	45°	60°	5°	15°	30°	45°	60°	5°	15°	30°	45°
9.0	38.4																		
10.0	36.0					16.7													
11.0	33.8	31.6				16.7													
12.0	31.9	30.2				16.7													
14.0	27.2	27.3	25.2			16.7	16.7				16.0								
16.0	19.5	21.4	23.5	22.1	21.1	16.7	16.7				15.5					10.9			
18.0	13.8	15.7	17.7	19.3	20.3	16.7	16.7	16.7			15.0	13.5				10.8			
20.0		10.9	13.1	14.4	15.2	12.9	15.1	15.9			14.5	13.0				10.5			
22.0				10.3	11.0	9.2	11.5	14.2	14.0		11.7	12.5				10.3	9.2		
24.0							8.3	11.0	12.8	12.9	8.7	11.3	10.8			10.0	8.8		
26.0								8.1	10.0	11.0		8.6	10.5			8.5	8.4		
28.0									7.3	8.3			9.3	9.3			8.1		
30.0													7.1	9.0	8.5		7.0	6.7	
32.0														7.2	8.4			6.5	
34.0															6.5				6.2
36.0																			5.5
θ (°)	72~ 84.5	71~ 84.5	74~ 84.5	73~ 84.5	73~ 84.5	72~ 84.5	72~ 84.5	74~ 84.5	74~ 84.5	76~ 84.5	72~ 84.5	74~ 84.5	75~ 84.5	77~ 84.5	77~ 84.5	73~ 84.5	74~ 84.5	77~ 84.5	80~ 84.5
標準フック	80t					35t					12.2t								
フック重量	1550kg					950kg					440kg								
標準巻掛本数	4					2					1								

カウンタウエイト 25t、アウトリガ張出幅 8.5m
45.4mブーム+2.3m+フルオートラフィングジブ

単位:t

ジブ長さ(m) 作業半径 (m)	10.3m オフセット					17.2m オフセット					24.1m オフセット					31.0m オフセット			
	5°	15°	30°	45°	60°	5°	15°	30°	45°	60°	5°	15°	30°	45°	60°	5°	15°	30°	45°
10.0	29.5																		
11.0	27.8																		
12.0	26.3	24.5				16.7													
14.0	23.6	22.2	20.6			16.7					15.3								
16.0	19.7	20.3	19.0	18.0		16.7	16.7				14.8					10.4			
18.0	14.0	15.9	17.5	16.7	16.2	16.7	16.7				14.4					10.3			
20.0		11.1	13.3	14.7	15.1	12.7	15.0	14.3			14.0	12.8				10.1			
22.0				10.6	11.4		11.4	13.3			11.4	12.4				9.9	9.0		
24.0								11.0	11.9			11.1				9.6	8.7		
26.0									10.0	10.8			10.4				8.3		
28.0										8.4				9.2			8.0		
30.0															8.8			6.6	
32.0																8.2			6.4
34.0																			
36.0																			5.5
θ (°)	74~ 84.5	73~ 84.5	76~ 84.5	75~ 84.5	76~ 84.5	76~ 84.5	76~ 84.5	78~ 84.5	78~ 84.5	77~ 84.5	76~ 84.5	78~ 84.5	80~ 84.5	82~ 84.5	82~ 84.5	76~ 84.5	78~ 84.5	80~ 84.5	81~ 84.5
標準フック	35t					35t					12.2t								
フック重量	950kg					950kg					440kg								
標準巻掛本数	3					2					1								

カウンタウエイト 25t、アウトリガ張出幅 8.5m

50.5mブーム+2.3m+フルオートラフティングジブ

単位:t

ジブ長さ(m) 作業半径 (m)	10.3m オフセット					17.2m オフセット					24.1m オフセット			31.0m オフセット	
	5°	15°	30°	45°	60°	5°	15°	30°	45°	60°	5°	15°	30°	5°	15°
11.0	21.2														
12.0	20.0														
14.0	17.8	16.8				16.5									
16.0	16.0	15.2	14.2			15.0					13.5				
18.0	14.1	13.9	13.1	12.4	11.9	13.6	12.5				12.4			9.1	
20.0			12.1	11.6	11.2	12.5	11.7				11.5			9.1	
22.0				10.7	10.5		10.8	9.8				9.6		9.1	
24.0								9.2	8.5			9.0		9.1	8.3
26.0									8.1	7.7			7.5		7.8
28.0										7.4			7.1		
θ(°)	75~ 84.5	77~ 84.5	77~ 84.5	76~ 84.5	77~ 84.5	76~ 84.5	77~ 84.5	78~ 84.5	79~ 84.5	79~ 84.5	78~ 84.5	79~ 84.5	80~ 84.5	77~ 84.5	80~ 84.5
標準フック	35t														
フック重量	950kg														
標準巻掛本数	2														

カウンタウエイト 25t、アウトリガ張出幅 8.5m

55.6mブーム+2.3m+フルオートラフティングジブ

単位:t

ジブ長さ(m) 作業半径 (m)	10.3m オフセット					17.2m オフセット				24.1m オフセット			31.0m オフセット	
	5°	15°	30°	45°	60°	5°	15°	30°	45°	5°	15°	5°	15°	
12.0	14.6													
14.0	14.6	14.5												
16.0	13.9	13.2				12.0								
18.0		12.1	11.2			11.6	10.7			9.4				
20.0			10.4	9.9	9.5		9.8			9.4		6.4		
22.0					8.9			8.3			8.5	6.4		
24.0											7.9			
26.0									6.9				6.4	
θ(°)	78~ 84.5	78~ 84.5	78~ 84.5	80~ 84.5	79~ 84.5	79~ 84.5	80~ 84.5	82~ 84.5	81~ 84.5	80~ 84.5	80~ 84.5	81~ 84.5	82~ 84.5	
標準フック	35t													
フック重量	950kg													
標準巻掛本数	2													

カウンタウエイト 25t、アウトリガ張出幅 8.5m

60.0mブーム+2.3m+フルオートラフティングジブ

単位:t

ジブ長さ(m) 作業半径 (m)	10.3m オフセット				17.2m オフセット		24.1m オフセット	31.0m オフセット
	5°	15°	30°	45°	5°	15°	5°	5°
14.0	12.0							
16.0	12.0	11.6			8.0			
18.0			9.9		8.0	7.1		
20.0				8.8	8.0		5.7	
θ(°)	80~ 84.5	81~ 84.5	82~ 84.5	81~ 84.5	82~ 84.5	83~ 84.5	83~ 84.5	
標準フック	12.2t							
フック重量	440kg							
標準巻掛本数	1							

フルオートラフィングジブ

カウンタウエイト 25t、アウトリガ張出幅 8.0m
40.4mブーム+2.3m+フルオートラフィングジブ

単位:t

ジブ長さ(m) 作業半径 (m)	10.3m オフセット					17.2m オフセット					24.1m オフセット					31.0m オフセット			
	5°	15°	30°	45°	60°	5°	15°	30°	45°	60°	5°	15°	30°	45°	60°	5°	15°	30°	45°
9.0	38.4																		
10.0	36.0					16.7													
11.0	33.8	31.6				16.7													
12.0	31.9	30.2				16.7													
14.0	24.3	26.6	25.2			16.7	16.7				16.0								
16.0	17.3	19.1	21.6	22.1	21.1	16.7	16.7				15.5					10.9			
18.0	11.8	13.7	15.9	17.4	18.4	15.3	16.7	16.7			15.0	13.5				10.8			
20.0			11.3	12.8	13.6	11.1	13.5	15.9			13.5	13.0				10.5			
22.0				9.5			10.0	12.7	14.0		10.1	12.5				10.3	9.2		
24.0								9.7	11.6	12.8		10.0	10.8			9.7	8.8		
26.0									8.8	9.9			10.5			8.4			
28.0										7.2			8.2	9.3		7.9			
30.0														8.3	8.5			6.7	
32.0															7.6			6.5	
34.0																			
36.0																			5.5
θ (°)	72~ 84.5	74~ 84.5	74~ 84.5	75~ 84.5	73~ 84.5	74~ 84.5	74~ 84.5	76~ 84.5	77~ 84.5	76~ 84.5	74~ 84.5	76~ 84.5	77~ 84.5	79~ 84.5	79~ 84.5	75~ 84.5	76~ 84.5	78~ 84.5	80~ 84.5
標準フック	80t					35t									12.2t				
フック重量	1550kg					950kg									440kg				
標準巻掛本数	4					2									1				

カウンタウエイト 25t、アウトリガ張出幅 8.0m
45.4mブーム+2.3m+フルオートラフィングジブ

単位:t

ジブ長さ(m) 作業半径 (m)	10.3m オフセット					17.2m オフセット					24.1m オフセット				31.0m オフセット				
	5°	15°	30°	45°	60°	5°	15°	30°	45°	60°	5°	15°	30°	45°	5°	15°	30°		
10.0	29.5																		
11.0	27.8																		
12.0	26.3	24.5				16.7													
14.0	23.6	22.2	20.6			16.7					15.3								
16.0	17.5	19.3	19.0	18.0		16.7	16.7				14.8					10.4			
18.0		13.9	16.1	16.7	16.2	15.2	16.7				14.4					10.3			
20.0			11.5	13.1	13.9		13.4	14.3			13.2	12.8				10.1			
22.0				9.8				12.7				12.4				9.9	9.0		
24.0								9.6	11.6			9.7				8.7			
26.0									8.8	10.0			10.3			8.3			
28.0																			
30.0																			6.6
θ (°)	76~ 84.5	76~ 84.5	76~ 84.5	77~ 84.5	76~ 84.5	78~ 84.5	78~ 84.5	78~ 84.5	78~ 84.5	79~ 84.5	77~ 84.5	78~ 84.5	81~ 84.5	82~ 84.5	78~ 84.5	79~ 84.5	82~ 84.5		
標準フック	35t					35t									12.2t				
フック重量	950kg					950kg									440kg				
標準巻掛本数	3					2									1				

カウンタウエイト 25t、アウトリガ張出幅 8.0m
50.5mブーム+2.3m+フルオートラフィングジブ

単位:t

ジブ長さ(m) 作業半径 (m)	10.3m オフセット				17.2m オフセット					24.1m オフセット			31.0m オフセット		
	5°	15°	30°	45°	5°	15°	30°	45°	60°	5°	15°	30°	5°	15°	
11.0	21.2														
12.0	20.0														
14.0	17.8	16.8				16.5									
16.0	16.0	15.2	14.2			15.0					13.5				
18.0		13.9	13.1	12.4	11.9	13.6	12.5				12.4			9.1	
20.0				11.6	11.2		11.7				11.5			9.1	
22.0							9.8				9.6			9.1	
24.0									8.5					8.3	
26.0										7.7			7.5		
θ (°)	77~ 84.5	79~ 84.5	79~ 84.5	79~ 84.5	79~ 84.5	78~ 84.5	79~ 84.5	80~ 84.5	81~ 84.5	81~ 84.5	78~ 84.5	80~ 84.5	82~ 84.5	79~ 84.5	82~ 84.5
標準フック	35t					35t								12.2t	
フック重量	950kg					950kg								440kg	
標準巻掛本数	2					2								1	

カウンタウエイト 25t、アウトリガ張出幅 8.0m
55.6mブーム+2.3m+フルオートラフィングジブ

単位:t

ジブ長さ(m) 作業半径 (m)	10.3m オフセット					17.2m オフセット			24.1m オフセット		31.0m オフセット
	5°	15°	30°	45°	60°	5°	15°	30°	5°	15°	5°
12.0	14.6										
14.0	14.6	14.5									
16.0	13.9	13.2									
18.0											
20.0											
22.0											
θ (°)	78~ 84.5	80~ 84.5	80~ 84.5	80~ 84.5	81~ 84.5	79~ 84.5	82~ 84.5	82~ 84.5	82~ 84.5	83~ 84.5	83~ 84.5
標準フック	35t					12.2t					
フック重量	950kg					440kg					
標準巻掛本数	2					1					

カウンタウエイト 25t、アウトリガ張出幅 8.0m
60.0mブーム+2.3m+フルオートラフィングジブ

単位:t

ジブ長さ(m) 作業半径 (m)	10.3m オフセット			17.2m オフセット	24.1m オフセット
	5°	15°	30°	5°	5°
14.0	12.0				
16.0		11.6		8.0	
18.0			9.9		7.1
θ (°)	82~ 84.5	81~ 84.5	82~ 84.5	83~ 84.5	83~ 84.5
標準フック	12.2t				
フック重量	440kg				
標準巻掛本数	1				

PS+フルオートラフィングジブ

PS+ブーム+フルオートラフィングジブ(FLJ)作業半径-揚程図

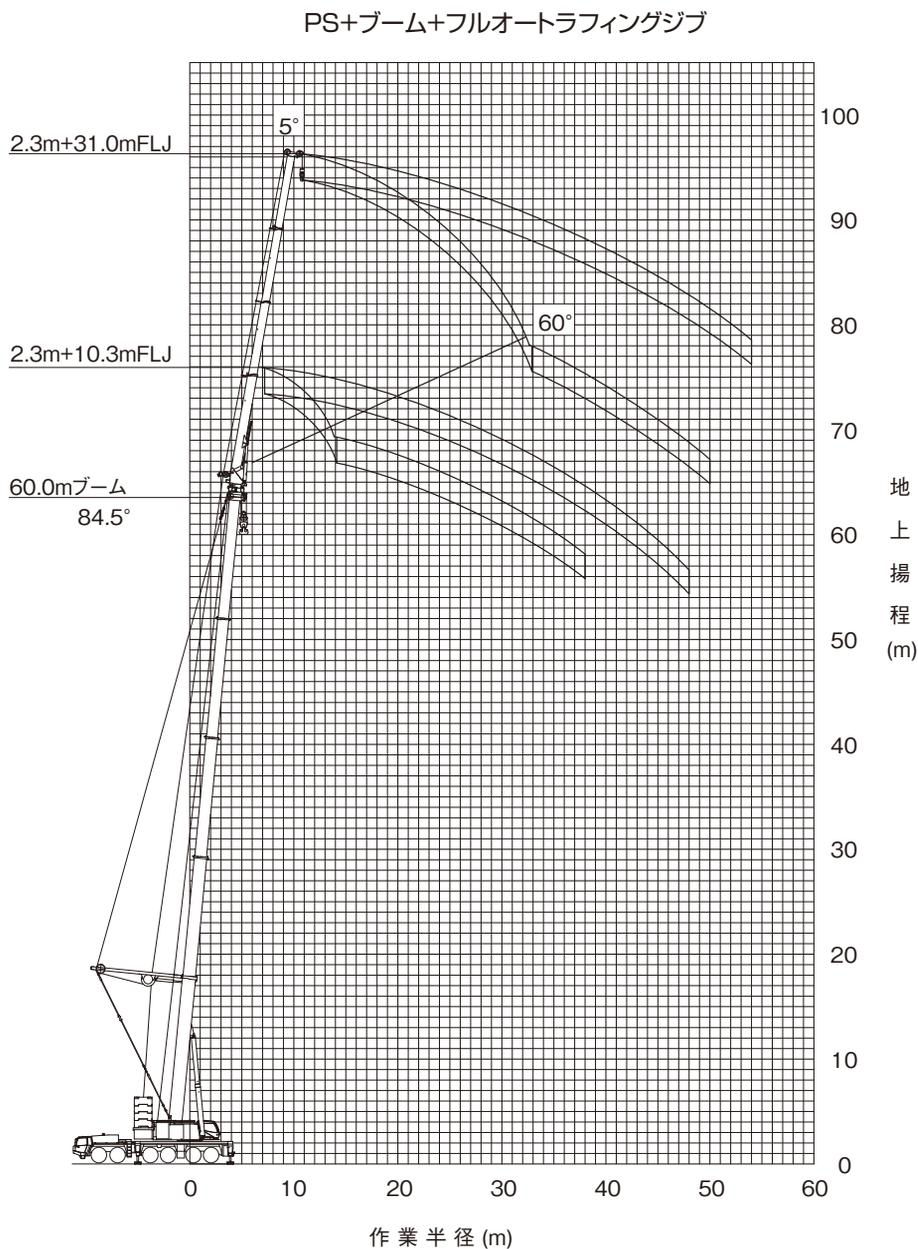

(注意)

- ◆ 上図はブームおよびジブのたわみを含んでいません。
- ◆ カウンタウエイト138t、アウトリガ張出幅8.5mの性能を図示しています。

PS+ブーム+フルオートラフィングジブ(FLJ)定格総荷重表

■ 定格総荷重表注意事項

◆性能設定のあるカウンタウエイトとアウトリガ張出幅の組合せを、下表に○印で示します。

アウトリガ張出幅	カウンタウエイト	138 t	118 t	98 t	78 t	58 t	47 t	25 t
8.5 m		○	○	○	○	○	○	○
8.0 m			○	○	○	○	○	
6.8 m					○	○	○	

◆定格総荷重は、つり具質量とフック質量(80トンフック: 1,550kg、35トンフック:950kg、12.2トンフック:440kg)を含んだ値を示します。

◆定格総荷重は、ブームとジブのたわみを含んだ実際の作業半径に基づいています。

◆各ブーム長さにおける各伸縮ブームの伸長状態(伸長割合%)は、下表のとおりです。

ブーム長さ	40.4 m	45.4 m	50.5 m	55.6 m	60.0 m
伸縮ブーム1	90	90	90	90	100
伸縮ブーム2	90	90	90	90	100
伸縮ブーム3	45	90	90	90	100
伸縮ブーム4	0	0	45	90	100

◆ブーム長さ40.4m未満での性能設定はありません。また、Bピン(ブーム固定ピン)を挿入していない状態では使用できません。

◆定格総荷重表中の標準巻掛本数より少ない本数で使用する場合、最大荷重の上限は下表のとおりです。

巻掛本数	3本	2本	1本
最大荷重	35.9t	24.1t	12.2t

◆定格総荷重は、アウトリガを水平堅土上に設置したときの値です。

◆定格総荷重表は、風による影響を含んでいません。瞬間最大風速が10m/s以上の風速では、クレーン作業を中止してください。

定格総荷重表中の線、および用語説明

◆太線より上側はクレーンの強度に、下側はクレーンの安定に基づいています。

◆「オフセット」はブームの中心線とジブの中心線とのなす角度を示します。

◆「 θ (°)」は、無負荷状態で作動可能なブーム起伏角度範囲を示します。

PS+フルオートラフィングジブ

カウンタウエイト 138t、アウトリガ張出幅 8.5m
PS+40.4mブーム+2.3m+フルオートラフィングジブ

単位:t

ジブ長さ(m) 作業半径 (m)	10.3m オフセット					17.2m オフセット					24.1m オフセット					31.0m オフセット				
	5°	15°	30°	45°	60°	5°	15°	30°	45°	60°	5°	15°	30°	45°	60°	5°	15°	30°	45°	60°
9.0	37.6																			
10.0	37.6					16.7														
11.0	37.6	37.6				16.7														
12.0	37.6	37.6				16.7														
14.0	37.6	37.6	30.3	25.6		16.7	16.7				16.4									
16.0	36.3	35.0	29.0	24.8	22.8	16.7	16.7				16.0					10.9				
18.0	31.7	30.8	27.8	24.2	22.4	16.7	16.7	16.7			15.6	14.0				10.9				
20.0	27.9	27.2	26.6	23.5	22.1	16.7	16.7	16.7	14.9		15.2	13.6				10.7				
22.0	24.6	24.2	23.7	23.0	21.9	16.7	16.7	16.7	14.5	13.1	14.7	13.1	11.6			10.5	9.7			
24.0	21.8	21.5	21.2	21.1	21.2	16.7	16.7	16.3	14.1	12.9	14.2	12.7	11.3			10.3	9.3			
26.0	19.4	19.2	19.0	18.9	19.0	16.7	16.7	15.7	13.7	12.7	13.7	12.3	11.0	9.8		10.0	8.9			
28.0	17.2	17.1	17.0	17.0	17.1	16.6	16.4	15.2	13.4	12.5	13.2	12.0	10.6	9.6		9.8	8.5	7.2		
30.0	15.3	15.3	15.2	15.2		15.0	14.9	14.7	13.1	12.4	12.8	11.7	10.3	9.3	8.5	9.5	8.2	7.0		
32.0	13.6	13.6	13.6	13.7		13.5	13.4	13.5	12.8	12.3	12.4	11.4	10.1	9.1	8.4	9.1	7.9	6.7		
34.0	12.1	12.1	12.2	12.2		12.1	12.1	12.2	12.3	12.2	11.8	11.1	9.8	8.9	8.3	8.7	7.6	6.5	5.7	
36.0	10.8	10.8	10.8	10.9		10.9	11.0	11.1	11.2	11.3	10.7	10.7	9.5	8.8	8.2	8.4	7.4	6.3	5.6	5.3
38.0	9.5	9.6	9.6	9.6		9.8	9.9	10.0	10.1		9.7	9.8	9.3	8.6	8.1	8.0	7.1	6.1	5.4	5.2
40.0	8.4	8.5	8.5			8.8	8.9	9.0	9.1		8.8	8.9	9.1	8.4	8.1	7.7	6.9	5.9	5.3	5.1
42.0	7.4	7.4	7.5			7.8	7.9	8.1	8.2		8.0	8.1	8.3	8.3	8.0	7.5	6.7	5.8	5.2	5.1
44.0	6.4	6.5	6.5			7.0	7.1	7.2	7.3		7.2	7.3	7.6	7.8		7.2	6.5	5.6	5.2	5.0
46.0	5.4	5.6				6.2	6.3	6.4			6.5	6.6	6.9	7.1		6.7	6.3	5.5	5.1	5.0
48.0	2.7	3.1				5.4	5.6	5.7			5.8	6.0	6.2	6.4		6.1	6.1	5.3	5.1	5.0
50.0						4.8	4.9	4.9			5.2	5.4	5.6	5.7		5.5	5.7	5.2	5.0	4.9
54.0						3.1	3.6				4.1	4.2	4.4			4.5	4.7	5.0	4.9	
58.0											3.1	3.2	3.3			3.6	3.7	4.0	4.1	
62.0												1.8				2.7	2.9	3.1		
66.0																2.0	2.1	2.2		
θ (°)	22~ 84.5	23~ 84.5	36~ 84.5	48~ 84.5	64~ 84.5	26~ 84.5	28~ 84.5	39~ 84.5	52~ 84.5	65~ 84.5	31~ 84.5	24~ 84.5	37~ 84.5	53~ 84.5	66~ 84.5	28~ 84.5	32~ 84.5	36~ 84.5	53~ 84.5	66~ 84.5
標準フック フック重量	80t 1550kg					35t 950kg					12.2t 440kg									
標準巻掛本数	4					2					1									

カウンタウエイト 138t、アウトリガ張出幅 8.5m
PS+45.4mブーム+2.3m+フルオートラフィングジブ

単位:t

ジブ長さ(m) 作業半径 (m)	10.3m オフセット					17.2m オフセット					24.1m オフセット					31.0m オフセット				
	5°	15°	30°	45°	60°	5°	15°	30°	45°	60°	5°	15°	30°	45°	60°	5°	15°	30°	45°	60°
10.0	28.6																			
11.0	28.6																			
12.0	28.6	28.6				16.7														
14.0	28.6	28.6	28.6			16.7					15.5									
16.0	28.6	28.6	28.6	25.2	23.0	16.7	16.7				15.3									
18.0	28.6	28.6	28.1	24.6	22.7	16.7	16.7				14.9	13.9				10.5				
20.0	26.2	25.5	24.9	24.0	22.4	16.7	16.7	16.7			14.7	13.5				10.3				
22.0	23.0	22.6	22.1	22.0	22.0	16.7	16.7	16.7	14.6		14.4	13.1				10.1	9.5			
24.0	20.3	20.0	19.7	19.6	19.7	16.7	16.7	16.6	14.2	12.9	14.1	12.7	11.3			9.9	9.2			
26.0	18.0	17.8	17.6	17.5	17.6	16.7	16.7	16.1	13.9	12.7	13.7	12.3	11.0			9.7	8.9			
28.0	15.9	15.8	15.7	15.7	15.8	15.4	15.2	15.1	13.6	12.6	13.3	12.0	10.6	9.6		9.5	8.6			
30.0	14.1	14.0	14.0	14.0	14.1	13.7	13.7	13.7	13.3	12.5	12.9	11.7	10.4	9.4	8.6	9.3	8.2	7.0		
32.0	12.4	12.4	12.5	12.5		12.3	12.3	12.4	12.5	12.4	11.9	11.4	10.1	9.2	8.4	9.2	8.0	6.8		
34.0	11.0	11.0	11.1	11.1		11.0	11.0	11.2	11.3	11.5	10.7	10.8	9.8	9.0	8.3	8.8	7.7	6.6	5.7	
36.0	9.6	9.7	9.8	9.8		9.8	9.9	10.0	10.2	10.3	9.7	9.8	9.6	8.8	8.2	8.5	7.4	6.4	5.6	
38.0	8.5	8.5	8.6	8.6		8.7	8.9	9.0	9.2	9.3	8.8	8.9	9.1	8.7	8.1	8.2	7.2	6.2	5.4	5.2
40.0	7.4	7.4	7.5	7.6		7.8	7.9	8.1	8.2		7.9	8.0	8.3	8.5	8.1	7.9	7.0	6.0	5.3	5.2
42.0	6.4	6.5	6.5			6.9	7.0	7.2	7.3		7.1	7.2	7.5	7.7	8.0	7.2	6.8	5.8	5.2	5.1
44.0	5.5	5.5	5.6			6.0	6.2	6.4	6.5		6.3	6.5	6.8	7.0	7.2	6.5	6.6	5.7	5.1	5.0
46.0	4.6	4.7	4.8			5.3	5.4	5.6	5.7		5.6	5.8	6.1	6.3		5.9	6.1	5.5	5.1	5.0
48.0	3.9	3.9	3.9			4.6	4.7	4.9	4.9		5.0	5.2	5.4	5.6		5.3	5.5	5.4	5.1	4.9
50.0	3.1	3.2				3.9	4.0	4.2			4.4	4.6	4.8	5.0		4.8	5.0	5.3	5.0	4.9
54.0						2.7	2.8	2.9			3.3	3.5	3.7	3.8		3.7	4.0	4.3	4.5	
58.0						1.7	1.7				2.3	2.5	2.7			2.8	3.0	3.3	3.5	
62.0											1.5	1.6	1.7			2.0	2.2	2.5	2.6	
66.0																1.5	1.6			
θ (°)	30~ 84.5	31~ 84.5	36~ 84.5	51~ 84.5	66~ 84.5	28~ 84.5	29~ 84.5	39~ 84.5	50~ 84.5	65~ 84.5	32~ 84.5	36~ 84.5	39~ 84.5	54~ 84.5	68~ 84.5	41~ 84.5	40~ 84.5	44~ 84.5	53~ 84.5	70~ 84.5
標準フック フック重量	35t 950kg					35t 950kg					12.2t 440kg									
標準巻掛本数	3					2					1									

カウンタウエイト 138t、アウトリガ張出幅 8.5m
PS+50.5mブーム+2.3m+フルオートラフィングジブ

単位:t

ジブ長さ(m) 作業半径 (m)	10.3m オフセット					17.2m オフセット					24.1m オフセット					31.0m オフセット					
	5°	15°	30°	45°	60°	5°	15°	30°	45°	60°	5°	15°	30°	45°	60°	5°	15°	30°	45°	60°	
11.0	21.0																				
12.0	21.0																				
14.0	21.0	20.4				15.9															
16.0	21.0	19.0	16.7	15.2		15.9	15.6				12.2										
18.0	19.7	17.8	15.7	14.4	13.6	15.9	14.5				12.2					9.0					
20.0	18.4	16.6	14.8	13.7	13.0	15.5	13.6	11.7			12.2	11.5				9.0					
22.0	17.2	15.7	14.0	13.0	12.4	14.5	12.8	11.1	10.0		12.2	10.9				9.0					
24.0	16.1	14.8	13.3	12.4	11.9	13.5	12.1	10.6	9.6	9.0	11.7	10.2				9.0	8.9				
26.0	15.1	13.9	12.7	11.9	11.5	12.7	11.4	10.0	9.2	8.6	10.9	9.7	8.4			9.0	8.7				
28.0	14.3	13.2	12.1	11.4	11.1	12.0	10.8	9.6	8.8	8.3	10.3	9.1	8.0			9.0	8.3				
30.0	13.2	12.6	11.6	11.0	10.7	11.3	10.2	9.1	8.4	8.0	9.7	8.7	7.6	6.9		8.8	7.8	6.8			
32.0	11.7	11.7	11.1	10.5	10.3	10.7	9.7	8.7	8.1	7.8	9.2	8.2	7.2	6.6	6.2	8.4	7.4	6.5			
34.0	10.3	10.3	10.3	10.2	10.0	10.1	9.3	8.4	7.8	7.5	8.7	7.8	6.9	6.4	5.9	7.9	7.1	6.2			
36.0	9.0	9.1	9.2	9.2		9.2	8.8	8.0	7.5	7.2	8.2	7.4	6.6	6.0	5.7	7.5	6.7	5.9	5.4		
38.0	7.9	8.0	8.0	8.1		8.2	8.2	7.7	7.1	6.9	7.8	7.1	6.3	5.7	5.4	7.1	6.4	5.6	5.1	4.7	
40.0	6.8	6.9	7.0	7.1		7.2	7.3	7.3	6.8	6.6	7.3	6.7	5.9	5.4	5.1	6.7	6.1	5.3	4.8	4.4	
42.0	5.9	6.0	6.1	6.1		6.3	6.5	6.7	6.5		6.5	6.3	5.6	5.2	4.9	6.4	5.7	5.0	4.5	4.2	
44.0	5.0	5.1	5.2	5.2		5.5	5.7	5.9	6.0		5.8	5.9	5.3	4.9	4.7	6.0	5.4	4.7	4.3	4.0	
46.0	4.2	4.3	4.4			4.8	5.0	5.1	5.3		5.1	5.3	5.0	4.7	4.5	5.4	5.1	4.5	4.1	3.8	
48.0	3.4	3.5	3.6			4.1	4.3	4.5	4.6		4.5	4.7	4.7	4.4	4.3	4.8	4.7	4.2	3.8	3.6	
50.0	2.7	2.8	2.9			3.5	3.6	3.8	3.9		3.9	4.1	4.4	4.2		4.3	4.5	4.0	3.6	3.5	
54.0	1.5	1.5				2.3	2.5	2.6			2.8	3.1	3.3	3.5		3.3	3.5	3.5	3.3	3.1	
58.0								1.5			1.9	2.1	2.3	2.4		2.4	2.6	2.9	2.9		
62.0																1.6	1.9	2.1	2.3		
66.0																			1.5		
θ(°)	31~ 84.5	32~ 84.5	40~ 84.5	50~ 84.5	63~ 84.5	41~ 84.5	43~ 84.5	39~ 84.5	52~ 84.5	66~ 84.5	44~ 84.5	47~ 84.5	50~ 84.5	52~ 84.5	65~ 84.5	46~ 84.5	50~ 84.5	55~ 84.5	52~ 84.5	68~ 84.5	
標準フック	35t										12.2t										
フック重量	950kg										440kg										
標準巻掛本数	2										1										

PS+FLJ

カウンタウエイト 138t、アウトリガ張出幅 8.5m
PS+55.6mブーム+2.3m+フルオートラフィングジブ

単位:t

ジブ長さ(m) 作業半径 (m)	10.3m オフセット					17.2m オフセット					24.1m オフセット					31.0m オフセット					
	5°	15°	30°	45°	60°	5°	15°	30°	45°	60°	5°	15°	30°	45°	60°	5°	15°	30°	45°	60°	
12.0	15.0																				
14.0	15.0	15.0				11.7															
16.0	15.0	15.0	14.5			11.7															
18.0	15.0	15.0	13.5	12.6	11.9	11.7	11.7				8.8										
20.0	15.0	13.9	12.6	11.8	11.3	11.7	11.7				8.8					6.8					
22.0	14.0	13.0	11.9	11.1	10.7	11.7	10.9	9.7			8.8	8.8				6.8					
24.0	13.0	12.1	11.1	10.5	10.1	11.2	10.2	9.1	8.4		8.8	8.8				6.8					
26.0	12.1	11.3	10.5	9.9	9.5	10.5	9.6	8.6	8.0	7.6	8.8	8.7	7.7			6.8	6.8				
28.0	11.3	10.5	9.7	9.2	8.8	9.8	9.0	8.1	7.5	7.1	8.8	8.1	7.2			6.8	6.8				
30.0	10.3	9.7	9.0	8.5	8.2	9.0	8.2	7.5	6.9	6.6	8.4	7.7	6.8	6.3		6.8	6.8				
32.0	9.4	8.9	8.3	7.9	7.6	8.2	7.6	6.9	6.4	6.1	7.7	7.0	6.3	5.8	5.5	6.8	6.5	5.7			
34.0	8.7	8.2	7.6	7.3	7.1	7.5	7.0	6.4	6.0	5.7	7.1	6.5	5.8	5.4	5.1	6.5	5.9	5.3			
36.0	7.9	7.5	7.0	6.8	6.6	6.9	6.4	5.9	5.5	5.3	6.5	6.0	5.4	5.0	4.7	6.0	5.5	4.9	4.5		
38.0	7.3	6.9	6.5	6.3		6.3	5.9	5.4	5.1	4.9	5.9	5.5	5.0	4.6	4.4	5.5	5.0	4.5	4.2		
40.0	6.4	6.3	6.0	5.8		5.7	5.4	5.0	4.7	4.6	5.4	5.0	4.6	4.3	4.1	5.0	4.6	4.2	3.9	3.7	
42.0	5.4	5.5	5.5	5.3		5.2	4.9	4.6	4.3	4.2	5.0	4.6	4.2	4.0	3.8	4.6	4.2	3.8	3.6	3.4	
44.0	4.6	4.7	4.8	4.8		4.8	4.5	4.2	4.0		4.5	4.2	3.9	3.7	3.5	4.2	3.9	3.5	3.3	3.1	
46.0	3.8	3.9	4.0	4.0		4.3	4.1	3.8	3.7		4.1	3.9	3.6	3.4	3.2	3.8	3.5	3.2	3.0	2.9	
48.0	3.0	3.1	3.2	3.3		3.7	3.7	3.5	3.4		3.7	3.5	3.3	3.1	3.0	3.5	3.2	3.0	2.8	2.7	
50.0	2.4	2.5	2.5			3.0	3.2	3.2	3.1		3.4	3.2	3.0	2.8	2.7	3.1	2.9	2.7	2.5	2.4	
54.0						1.9	2.1	2.3	2.3		2.5	2.6	2.4	2.3		2.5	2.4	2.2	2.1	2.0	
58.0											1.6	1.8	2.0	1.9		2.0	1.9	1.8	1.7		
62.0																			1.5		
θ(°)	44~ 84.5	45~ 84.5	46~ 84.5	50~ 84.5	64~ 84.5	46~ 84.5	48~ 84.5	51~ 84.5	52~ 84.5	66~ 84.5	49~ 84.5	52~ 84.5	55~ 84.5	57~ 84.5	67~ 84.5	55~ 84.5	54~ 84.5	62~ 84.5	66~ 84.5	71~ 84.5	
標準フック	35t										12.2t										
フック重量	950kg										440kg										
標準巻掛本数	2										1										

PS+フルオートラフィングジブ

カウンタウエイト 138t、アウトリガ張出幅 8.5m
PS+60.0mブーム+2.3m+フルオートラフィングジブ

単位:t

ジブ長さ(m) 作業半径 (m)	10.3m オフセット					17.2m オフセット					24.1m オフセット					31.0m オフセット				
	5°	15°	30°	45°	60°	5°	15°	30°	45°	60°	5°	15°	30°	45°	60°	5°	15°	30°	45°	60°
14.0	11.5																			
16.0	11.5	11.5				8.7														
18.0	11.5	11.5	11.5	11.5		8.7	8.7						6.8							
20.0	11.5	11.5	11.5	11.0	10.5	8.7	8.7						6.8					5.3		
22.0	11.5	11.5	11.0	10.4	9.9	8.7	8.7	8.7					6.8	6.8				5.3		
24.0	11.5	11.3	10.2	9.5	9.2	8.7	8.7	8.4					6.8	6.8				5.3		
26.0	11.2	10.4	9.3	8.7	8.4	8.7	8.7	7.6	7.0	6.6	6.8	6.8					5.3	5.3		
28.0	10.3	9.4	8.5	7.9	7.7	8.7	8.0	7.0	6.4	6.1	6.8	6.8	5.9				5.3	5.3		
30.0	9.2	8.5	7.7	7.3	7.1	8.1	7.2	6.4	5.9	5.6	6.8	6.2	5.4				5.3	5.3		
32.0	8.3	7.6	7.0	6.6	6.5	7.3	6.6	5.8	5.4	5.2	6.3	5.6	4.9	4.5			5.3	5.0		
34.0	7.4	6.9	6.3	6.0	5.9	6.6	5.9	5.3	4.9	4.8	5.7	5.1	4.5	4.1	3.9		5.1	4.5	4.0	
36.0	6.6	6.2	5.7	5.5	5.4	5.9	5.4	4.8	4.5	4.4	5.1	4.6	4.1	3.8	3.6		4.6	4.1	3.6	
38.0	5.9	5.5	5.1	4.9	4.9	5.3	4.8	4.4	4.1	4.0	4.6	4.2	3.7	3.5	3.3		4.2	3.7	3.3	3.0
40.0	5.3	5.0	4.6	4.5		4.7	4.3	4.0	3.7	3.7	4.1	3.8	3.4	3.1	3.0		3.7	3.4	3.0	2.8
42.0	4.4	4.4	4.1	4.0		4.2	3.9	3.6	3.4	3.3	3.7	3.4	3.0	2.8	2.8		3.3	3.0	2.7	2.5
44.0	3.6	3.7	3.7	3.6		3.7	3.5	3.2	3.0	3.0	3.3	3.0	2.7	2.6	2.5	3.0	2.7	2.4	2.3	2.2
46.0	2.8	2.9	3.1	3.1		3.3	3.1	2.8	2.7		2.9	2.7	2.4	2.3	2.3		2.6	2.4	2.2	2.0
48.0	2.1	2.2	2.4	2.4		2.9	2.7	2.5	2.4		2.6	2.4	2.2	2.1	2.0		2.3	2.1	1.9	1.8
50.0		1.6	1.7	1.7		2.2	2.4	2.2	2.1		2.2	2.1	1.9	1.8	1.8		2.0	1.9	1.7	1.6
54.0								1.6	1.6		1.6	1.5					1.5			
θ(°)	51~ 84.5	50~ 84.5	51~ 84.5	52~ 84.5	65~ 84.5	55~ 84.5	57~ 84.5	55~ 84.5	56~ 84.5	67~ 84.5	56~ 84.5	58~ 84.5	65~ 84.5	68~ 84.5	69~ 84.5	60~ 84.5	66~ 84.5	71~ 84.5	75~ 84.5	77~ 84.5
標準フック											12.2t									
フック重量											440kg									
標準巻掛本数											1									

カウンタウエイト 118t、アウトリガ張出幅 8.5m
PS+40.4mブーム+2.3m+フルオートラフィングジブ

単位:t

ジブ長さ(m) 作業半径 (m)	10.3m オフセット					17.2m オフセット					24.1m オフセット					31.0m オフセット				
	5°	15°	30°	45°	60°	5°	15°	30°	45°	60°	5°	15°	30°	45°	60°	5°	15°	30°	45°	60°
9.0	37.6																			
10.0	37.6					16.7														
11.0	37.6	37.6				16.7														
12.0	37.6	37.6				16.7														
14.0	37.6	37.6	30.3	25.6		16.7	16.7				16.4									
16.0	36.3	35.0	29.0	24.8	22.8	16.7	16.7				16.0						10.9			
18.0	31.7	30.8	27.8	24.2	22.4	16.7	16.7	16.7			15.6	14.0					10.9			
20.0	27.9	27.2	26.6	23.5	22.1	16.7	16.7	16.7	14.9		15.2	13.6					10.7			
22.0	24.6	24.2	23.7	23.0	21.9	16.7	16.7	16.7	14.5	13.1	14.7	13.1	11.6				10.5	9.7		
24.0	21.8	21.5	21.2	21.1	21.2	16.7	16.7	16.3	14.1	12.9	14.2	12.7	11.3				10.3	9.3		
26.0	19.4	19.2	19.0	18.9	19.0	16.7	16.7	15.7	13.7	12.7	13.7	12.3	11.0	9.8			10.0	8.9		
28.0	17.2	17.1	17.0	17.0	17.1	16.6	16.4	15.2	13.4	12.5	13.2	12.0	10.6	9.6			9.8	8.5	7.2	
30.0	15.3	15.3	15.2	15.2		15.0	14.9	14.7	13.1	12.4	12.8	11.7	10.3	9.3	8.5		9.5	8.2	7.0	
32.0	13.6	13.6	13.6	13.7		13.5	13.4	13.5	12.8	12.3	12.4	11.4	10.1	9.1	8.4		9.1	7.9	6.7	
34.0	12.1	12.1	12.2	12.2		12.1	12.1	12.2	12.3	12.2	11.8	11.1	9.8	8.9	8.3		8.7	7.6	6.5	5.7
36.0	10.8	10.8	10.8	10.9		10.9	11.0	11.1	11.2	11.3	10.7	10.7	9.5	8.8	8.2		8.4	7.4	6.3	5.6
38.0	9.5	9.6	9.6	9.6		9.8	9.9	10.0	10.1		9.7	9.8	9.3	8.6	8.1		8.0	7.1	6.1	5.4
40.0	8.4	8.5	8.5			8.8	8.9	9.0	9.1		8.8	8.9	9.1	8.4	8.1		7.7	6.9	5.9	5.3
42.0	7.4	7.4	7.5			7.8	7.9	8.1	8.2		8.0	8.1	8.3	8.3	8.0		7.5	6.7	5.8	5.2
44.0	6.3	6.5	6.5			7.0	7.1	7.2	7.3		7.2	7.3	7.6	7.8			7.2	6.5	5.6	5.2
46.0	4.8	5.0				6.2	6.3	6.4			6.5	6.6	6.9	7.1			6.7	6.3	5.5	5.1
48.0	2.7	3.1				5.4	5.6	5.7			5.8	6.0	6.2	6.4			6.1	6.1	5.3	5.1
50.0						4.8	4.9	4.9			5.2	5.4	5.6	5.7			5.5	5.7	5.2	5.0
54.0						3.0	3.2				4.1	4.2	4.4				4.5	4.7	5.0	4.9
58.0											3.1	3.2	3.3				3.6	3.7	4.0	4.1
62.0												1.8					2.7	2.9	3.1	
66.0																	2.0	2.1	2.2	
θ(°)	22~ 84.5	23~ 84.5	36~ 84.5	48~ 84.5	64~ 84.5	26~ 84.5	28~ 84.5	39~ 84.5	52~ 84.5	65~ 84.5	31~ 84.5	24~ 84.5	37~ 84.5	53~ 84.5	66~ 84.5	28~ 84.5	32~ 84.5	36~ 84.5	53~ 84.5	66~ 84.5
標準フック											35t									
フック重量											950kg									
標準巻掛本数											2									

カウンタウエイト 118t、アウトリガ張出幅 8.5m
PS+45.4mブーム+2.3m+フルオートラフィングジブ

単位:t

ジブ長さ(m) 作業半径 (m)	10.3m オフセット					17.2m オフセット					24.1m オフセット					31.0m オフセット						
	5°	15°	30°	45°	60°	5°	15°	30°	45°	60°	5°	15°	30°	45°	60°	5°	15°	30°	45°	60°		
10.0	28.6																					
11.0	28.6																					
12.0	28.6	28.6				16.7																
14.0	28.6	28.6	28.6			16.7					15.5											
16.0	28.6	28.6	28.6	25.2	23.0	16.7	16.7				15.3											
18.0	28.6	28.6	28.1	24.6	22.7	16.7	16.7				14.9	13.9				10.5						
20.0	26.2	25.5	24.9	24.0	22.4	16.7	16.7	16.7			14.7	13.5				10.3						
22.0	23.0	22.6	22.1	22.0	22.0	16.7	16.7	16.7	14.6		14.4	13.1				10.1	9.5					
24.0	20.3	20.0	19.7	19.6	19.7	16.7	16.7	16.6	14.2	12.9	14.1	12.7	11.3			9.9	9.2					
26.0	18.0	17.8	17.6	17.5	17.6	16.7	16.7	16.1	13.9	12.7	13.7	12.3	11.0			9.7	8.9					
28.0	15.9	15.8	15.7	15.7	15.8	15.4	15.2	15.1	13.6	12.6	13.3	12.0	10.6	9.6		9.5	8.6					
30.0	14.1	14.0	14.0	14.0	14.1	13.7	13.7	13.7	13.3	12.5	12.9	11.7	10.4	9.4	8.6	9.3	8.2	7.0				
32.0	12.4	12.4	12.5	12.5		12.3	12.3	12.4	12.5	12.4	11.9	11.4	10.1	9.2	8.4	9.2	8.0	6.8				
34.0	11.0	11.0	11.1	11.1		11.0	11.0	11.2	11.3	11.5	10.7	10.8	9.8	9.0	8.3	8.8	7.7	6.6	5.7			
36.0	9.6	9.7	9.8	9.8		9.8	9.9	10.0	10.2	10.3	9.7	9.8	9.6	8.8	8.2	8.5	7.4	6.4	5.6			
38.0	8.5	8.5	8.6	8.6		8.7	8.9	9.0	9.2	9.3	8.8	8.9	9.1	8.7	8.1	8.2	7.2	6.2	5.4	5.2		
40.0	7.4	7.4	7.5	7.6		7.8	7.9	8.1	8.2		7.9	8.0	8.3	8.5	8.1	7.9	7.0	6.0	5.3	5.2		
42.0	6.4	6.5	6.5			6.9	7.0	7.2	7.3		7.1	7.2	7.5	7.7	8.0	7.2	6.8	5.8	5.2	5.1		
44.0	5.5	5.5	5.6			6.0	6.2	6.4	6.5		6.3	6.5	6.8	7.0	7.2	6.5	6.6	5.7	5.1	5.0		
46.0	4.6	4.7	4.8			5.3	5.4	5.6	5.7		5.6	5.8	6.1	6.3		5.9	6.1	5.5	5.1	5.0		
48.0	3.7	3.9	3.9			4.6	4.7	4.9	4.9		5.0	5.2	5.4	5.6		5.3	5.5	5.4	5.1	4.9		
50.0	2.5	2.7				3.9	4.0	4.2			4.4	4.6	4.8	5.0		4.8	5.0	5.3	5.0	4.9		
54.0						2.7	2.8	2.9			3.3	3.5	3.7	3.8		3.7	4.0	4.3	4.5			
58.0											2.3	2.5	2.7			2.8	3.0	3.3	3.5			
62.0											1.5	1.6	1.7			2.0	2.2	2.5	2.6			
66.0																1.5	1.6					
θ(°)	30~ 84.5	31~ 84.5	36~ 84.5	51~ 84.5	66~ 84.5	36~ 84.5	38~ 84.5	39~ 84.5	50~ 84.5	65~ 84.5	32~ 84.5	36~ 84.5	39~ 84.5	54~ 84.5	68~ 84.5	41~ 84.5	40~ 84.5	44~ 84.5	53~ 84.5	70~ 84.5		
標準フック	35t					35t					35t					12.2t						
フック重量	950kg					950kg					950kg					440kg						
標準巻掛本数	3					2					1					1						

PS+FLJ

カウンタウエイト 118t、アウトリガ張出幅 8.5m
PS+50.5mブーム+2.3m+フルオートラフィングジブ

単位:t

ジブ長さ(m) 作業半径 (m)	10.3m オフセット					17.2m オフセット					24.1m オフセット					31.0m オフセット						
	5°	15°	30°	45°	60°	5°	15°	30°	45°	60°	5°	15°	30°	45°	60°	5°	15°	30°	45°	60°		
11.0	21.0																					
12.0	21.0																					
14.0	21.0	20.4				15.9																
16.0	21.0	19.0	16.7	15.2		15.9	15.6				12.2											
18.0	19.7	17.8	15.7	14.4	13.6	15.9	14.5				12.2					9.0						
20.0	18.4	16.6	14.8	13.7	13.0	15.5	13.6	11.7			12.2	11.5				9.0						
22.0	17.2	15.7	14.0	13.0	12.4	14.5	12.8	11.1	10.0		12.2	10.9				9.0						
24.0	16.1	14.8	13.3	12.4	11.9	13.5	12.1	10.6	9.6	9.0	11.7	10.2				9.0	8.9					
26.0	15.1	13.9	12.7	11.9	11.5	12.7	11.4	10.0	9.2	8.6	10.9	9.7	8.4			9.0	8.7					
28.0	14.3	13.2	12.1	11.4	11.1	12.0	10.8	9.6	8.8	8.3	10.3	9.1	8.0			9.0	8.3					
30.0	13.2	12.6	11.6	11.0	10.7	11.3	10.2	9.1	8.4	8.0	9.7	8.7	7.6	6.9		8.8	7.8	6.8				
32.0	11.7	11.7	11.1	10.5	10.3	10.7	9.7	8.7	8.1	7.8	9.2	8.2	7.2	6.6	6.2	8.4	7.4	6.5				
34.0	10.3	10.3	10.3	10.2	10.0	10.1	9.3	8.4	7.8	7.5	8.7	7.8	6.9	6.4	5.9	7.9	7.1	6.2				
36.0	9.0	9.1	9.2	9.2		9.2	8.8	8.0	7.5	7.2	8.2	7.4	6.6	6.0	5.7	7.5	6.7	5.9	5.4			
38.0	7.9	8.0	8.0	8.1		8.2	8.2	7.7	7.1	6.9	7.8	7.1	6.3	5.7	5.4	7.1	6.4	5.6	5.1	4.7		
40.0	6.8	6.9	7.0	7.1		7.2	7.3	7.3	6.8	6.6	7.3	6.7	5.9	5.4	5.1	6.7	6.1	5.3	4.8	4.4		
42.0	5.9	6.0	6.1	6.1		6.3	6.5	6.7	6.5		6.5	6.3	5.6	5.2	4.9	6.4	5.7	5.0	4.5	4.2		
44.0	5.0	5.1	5.2	5.2		5.5	5.7	5.9	6.0		5.8	5.9	5.3	4.9	4.7	6.0	5.4	4.7	4.3	4.0		
46.0	4.2	4.3	4.4			4.8	5.0	5.1	5.3		5.1	5.3	5.0	4.7	4.5	5.4	5.1	4.5	4.1	3.8		
48.0	3.4	3.5	3.6			4.1	4.3	4.5	4.6		4.5	4.7	4.7	4.4	4.3	4.8	4.7	4.2	3.8	3.6		
50.0	2.7	2.8	2.9			3.5	3.6	3.8	3.9		3.9	4.1	4.4	4.2		4.3	4.5	4.0	3.6	3.5		
54.0						2.3	2.5	2.6			2.8	3.1	3.3	3.5		3.3	3.5	3.5	3.3	3.1		
58.0								1.5			1.9	2.1	2.3	2.4		2.4	2.6	2.9	2.9			
62.0																1.6	1.9	2.1	2.3			
66.0																						1.5
θ(°)	38~ 84.5	39~ 84.5	40~ 84.5	50~ 84.5	63~ 84.5	41~ 84.5	43~ 84.5	39~ 84.5	52~ 84.5	66~ 84.5	44~ 84.5	47~ 84.5	50~ 84.5	52~ 84.5	65~ 84.5	46~ 84.5	50~ 84.5	55~ 84.5	52~ 84.5	68~ 84.5		
標準フック	35t					35t					35t					12.2t						
フック重量	950kg					950kg					950kg					440kg						
標準巻掛本数	2					2					1					1						

PS+フルオートラフィングジブ

カウンタウエイト 118t、アウトリガ張出幅 8.5m
PS+55.6mブーム+2.3m+フルオートラフィングジブ

単位:t

ジブ長さ(m) 作業半径 (m)	10.3m オフセット					17.2m オフセット					24.1m オフセット					31.0m オフセット				
	5°	15°	30°	45°	60°	5°	15°	30°	45°	60°	5°	15°	30°	45°	60°	5°	15°	30°	45°	60°
12.0	15.0																			
14.0	15.0	15.0				11.7														
16.0	15.0	15.0	14.5			11.7														
18.0	15.0	15.0	13.5	12.6	11.9	11.7	11.7				8.8									
20.0	15.0	13.9	12.6	11.8	11.3	11.7	11.7				8.8					6.8				
22.0	14.0	13.0	11.9	11.1	10.7	11.7	10.9	9.7			8.8	8.8				6.8				
24.0	13.0	12.1	11.1	10.5	10.1	11.2	10.2	9.1	8.4		8.8	8.8				6.8				
26.0	12.1	11.3	10.5	9.9	9.5	10.5	9.6	8.6	8.0	7.6	8.8	8.7	7.7			6.8	6.8			
28.0	11.3	10.5	9.7	9.2	8.8	9.8	9.0	8.1	7.5	7.1	8.8	8.1	7.2			6.8	6.8			
30.0	10.3	9.7	9.0	8.5	8.2	9.0	8.2	7.5	6.9	6.6	8.4	7.7	6.8	6.3		6.8	6.8			
32.0	9.4	8.9	8.3	7.9	7.6	8.2	7.6	6.9	6.4	6.1	7.7	7.0	6.3	5.8	5.5	6.8	6.5	5.7		
34.0	8.7	8.2	7.6	7.3	7.1	7.5	7.0	6.4	6.0	5.7	7.1	6.5	5.8	5.4	5.1	6.5	5.9	5.3		
36.0	7.9	7.5	7.0	6.8	6.6	6.9	6.4	5.9	5.5	5.3	6.5	6.0	5.4	5.0	4.7	6.0	5.5	4.9	4.5	
38.0	7.3	6.9	6.5	6.3		6.3	5.9	5.4	5.1	4.9	5.9	5.5	5.0	4.6	4.4	5.5	5.0	4.5	4.2	
40.0	6.4	6.3	6.0	5.8		5.7	5.4	5.0	4.7	4.6	5.4	5.0	4.6	4.3	4.1	5.0	4.6	4.2	3.9	3.7
42.0	5.4	5.5	5.5	5.3		5.2	4.9	4.6	4.3	4.2	5.0	4.6	4.2	4.0	3.8	4.6	4.2	3.8	3.6	3.4
44.0	4.6	4.7	4.8	4.8		4.8	4.5	4.2	4.0		4.5	4.2	3.9	3.7	3.5	4.2	3.9	3.5	3.3	3.1
46.0	3.8	3.9	4.0	4.0		4.3	4.1	3.8	3.7		4.1	3.9	3.6	3.4	3.2	3.8	3.5	3.2	3.0	2.9
48.0	3.0	3.1	3.2	3.3		3.7	3.7	3.5	3.4		3.7	3.5	3.3	3.1	3.0	3.5	3.2	3.0	2.8	2.7
50.0	2.4	2.5	2.5			3.0	3.2	3.2	3.1		3.4	3.2	3.0	2.8	2.7	3.1	2.9	2.7	2.5	2.4
54.0						1.9	2.1	2.3	2.3		2.5	2.6	2.4	2.3		2.5	2.4	2.2	2.1	2.0
58.0											1.6	1.8	2.0	1.9		2.0	1.9	1.8	1.7	
62.0																	1.5			
θ(°)	44~ 84.5	45~ 84.5	46~ 84.5	50~ 84.5	64~ 84.5	46~ 84.5	48~ 84.5	51~ 84.5	52~ 84.5	66~ 84.5	49~ 84.5	52~ 84.5	55~ 84.5	57~ 84.5	67~ 84.5	55~ 84.5	54~ 84.5	62~ 84.5	66~ 84.5	71~ 84.5
標準フック			35t										12.2t							
フック重量			950kg										440kg							
標準巻掛本数			2										1							

カウンタウエイト 118t、アウトリガ張出幅 8.5m
PS+60.0mブーム+2.3m+フルオートラフィングジブ

単位:t

ジブ長さ(m) 作業半径 (m)	10.3m オフセット					17.2m オフセット					24.1m オフセット					31.0m オフセット				
	5°	15°	30°	45°	60°	5°	15°	30°	45°	60°	5°	15°	30°	45°	60°	5°	15°	30°	45°	60°
14.0	11.5																			
16.0	11.5	11.5				8.7														
18.0	11.5	11.5	11.5	11.5		8.7	8.7				6.8									
20.0	11.5	11.5	11.5	11.0	10.5	8.7	8.7				6.8					5.3				
22.0	11.5	11.5	11.0	10.4	9.9	8.7	8.7	8.7			6.8	6.8				5.3				
24.0	11.5	11.3	10.2	9.5	9.2	8.7	8.7	8.4			6.8	6.8				5.3				
26.0	11.2	10.4	9.3	8.7	8.4	8.7	8.7	7.6	7.0	6.6	6.8	6.8				5.3	5.3			
28.0	10.3	9.4	8.5	7.9	7.7	8.7	8.0	7.0	6.4	6.1	6.8	6.8	5.9			5.3	5.3			
30.0	9.2	8.5	7.7	7.3	7.1	8.1	7.2	6.4	5.9	5.6	6.8	6.2	5.4			5.3	5.3			
32.0	8.3	7.6	7.0	6.6	6.5	7.3	6.6	5.8	5.4	5.2	6.3	5.6	4.9	4.5		5.3	5.0			
34.0	7.4	6.9	6.3	6.0	5.9	6.6	5.9	5.3	4.9	4.8	5.7	5.1	4.5	4.1	3.9	5.1	4.5	4.0		
36.0	6.6	6.2	5.7	5.5	5.4	5.9	5.4	4.8	4.5	4.4	5.1	4.6	4.1	3.8	3.6	4.6	4.1	3.6		
38.0	5.9	5.5	5.1	4.9	4.9	5.3	4.8	4.4	4.1	4.0	4.6	4.2	3.7	3.5	3.3	4.2	3.7	3.3	3.0	
40.0	5.3	5.0	4.6	4.5		4.7	4.3	4.0	3.7	3.7	4.1	3.8	3.4	3.1	3.0	3.7	3.4	3.0	2.8	
42.0	4.4	4.4	4.1	4.0		4.2	3.9	3.6	3.4	3.3	3.7	3.4	3.0	2.8	2.8	3.3	3.0	2.7	2.5	2.4
44.0	3.6	3.7	3.7	3.6		3.7	3.5	3.2	3.0	3.0	3.3	3.0	2.7	2.6	2.5	3.0	2.7	2.4	2.3	2.2
46.0	2.8	2.9	3.1	3.1		3.3	3.1	2.8	2.7		2.9	2.7	2.4	2.3	2.3	2.6	2.4	2.2	2.0	2.0
48.0	2.1	2.2	2.4	2.4		2.9	2.7	2.5	2.4		2.6	2.4	2.2	2.1	2.0	2.3	2.1	1.9	1.8	1.8
50.0		1.6	1.7	1.7		2.2	2.4	2.2	2.1		2.2	2.1	1.9	1.8	1.8	2.0	1.9	1.7	1.6	1.6
54.0								1.6	1.6		1.6	1.5				1.5				
θ(°)	51~ 84.5	50~ 84.5	51~ 84.5	52~ 84.5	65~ 84.5	55~ 84.5	57~ 84.5	55~ 84.5	56~ 84.5	67~ 84.5	56~ 84.5	58~ 84.5	65~ 84.5	68~ 84.5	69~ 84.5	60~ 84.5	66~ 84.5	71~ 84.5	75~ 84.5	77~ 84.5
標準フック													12.2t							
フック重量													440kg							
標準巻掛本数													1							

カウンタウエイト 118t、アウトリガ張出幅 8.0m
PS+40.4mブーム+2.3m+フルオートラフィングジブ

単位:t

ジブ長さ(m) 作業半径 (m)	10.3m オフセット					17.2m オフセット					24.1m オフセット					31.0m オフセット				
	5°	15°	30°	45°	60°	5°	15°	30°	45°	60°	5°	15°	30°	45°	60°	5°	15°	30°	45°	60°
9.0	37.6																			
10.0	37.6					16.7														
11.0	37.6	37.6				16.7														
12.0	37.6	37.6				16.7														
14.0	37.6	37.6	30.3	25.6		16.7	16.7				16.4									
16.0	36.3	35.0	29.0	24.8	22.8	16.7	16.7				16.0					10.9				
18.0	31.7	30.8	27.8	24.2	22.4	16.7	16.7	16.7			15.6	14.0				10.9				
20.0	27.9	27.2	26.6	23.5	22.1	16.7	16.7	16.7	14.9		15.2	13.6				10.7				
22.0	24.6	24.2	23.7	23.0	21.9	16.7	16.7	16.7	14.5	13.1	14.7	13.1	11.6			10.5	9.7			
24.0	21.8	21.5	21.2	21.1	21.2	16.7	16.7	16.3	14.1	12.9	14.2	12.7	11.3			10.3	9.3			
26.0	19.4	19.2	19.0	18.9	19.0	16.7	16.7	15.7	13.7	12.7	13.7	12.3	11.0	9.8		10.0	8.9			
28.0	17.2	17.1	17.0	17.0	17.1	16.6	16.4	15.2	13.4	12.5	13.2	12.0	10.6	9.6		9.8	8.5	7.2		
30.0	15.3	15.3	15.2	15.2		15.0	14.9	14.7	13.1	12.4	12.8	11.7	10.3	9.3	8.5	9.5	8.2	7.0		
32.0	13.6	13.6	13.6	13.7		13.5	13.4	13.5	12.8	12.3	12.4	11.4	10.1	9.1	8.4	9.1	7.9	6.7		
34.0	12.1	12.1	12.2	12.2		12.1	12.1	12.2	12.3	12.2	11.8	11.1	9.8	8.9	8.3	8.7	7.6	6.5	5.7	
36.0	10.8	10.8	10.8	10.9		10.9	11.0	11.1	11.2	11.3	10.7	10.7	9.5	8.8	8.2	8.4	7.4	6.3	5.6	5.3
38.0	9.5	9.6	9.6	9.6		9.8	9.9	10.0	10.1		9.7	9.8	9.3	8.6	8.1	8.0	7.1	6.1	5.4	5.2
40.0	8.4	8.5	8.5			8.8	8.9	9.0	9.1		8.8	8.9	9.1	8.4	8.1	7.7	6.9	5.9	5.3	5.1
42.0	7.3	7.4	7.5			7.8	7.9	8.1	8.2		8.0	8.1	8.3	8.3	8.0	7.5	6.7	5.8	5.2	5.1
44.0	5.7	6.0	6.2			7.0	7.1	7.2	7.3		7.2	7.3	7.6	7.8		7.2	6.5	5.6	5.2	5.0
46.0	4.3	4.5				6.2	6.3	6.4			6.5	6.6	6.9	7.1		6.7	6.3	5.5	5.1	5.0
48.0	2.7	3.1				5.4	5.6	5.7			5.8	6.0	6.2	6.4		6.1	6.1	5.3	5.1	5.0
50.0						4.7	4.9	4.9			5.2	5.4	5.6	5.7		5.5	5.7	5.2	5.0	4.9
54.0						2.5	2.8				4.1	4.2	4.4			4.5	4.7	5.0	4.9	
58.0											2.9	3.2	3.3			3.6	3.7	4.0	4.1	
62.0												1.5				2.7	2.9	3.1		
66.0																1.8	2.1	2.2		
θ(°)	22~ 84.5	23~ 84.5	36~ 84.5	48~ 84.5	64~ 84.5	26~ 84.5	28~ 84.5	39~ 84.5	52~ 84.5	65~ 84.5	31~ 84.5	24~ 84.5	37~ 84.5	53~ 84.5	66~ 84.5	28~ 84.5	32~ 84.5	36~ 84.5	53~ 84.5	66~ 84.5
標準フック	80t					35t					12.2t									
フック重量	1550kg					950kg					440kg									
標準巻掛本数	4					2					1									

PS+FLJ

カウンタウエイト 118t、アウトリガ張出幅 8.0m
PS+45.4mブーム+2.3m+フルオートラフィングジブ

単位:t

ジブ長さ(m) 作業半径 (m)	10.3m オフセット					17.2m オフセット					24.1m オフセット					31.0m オフセット				
	5°	15°	30°	45°	60°	5°	15°	30°	45°	60°	5°	15°	30°	45°	60°	5°	15°	30°	45°	60°
10.0	28.6																			
11.0	28.6																			
12.0	28.6	28.6				16.7														
14.0	28.6	28.6	28.6			16.7					15.5									
16.0	28.6	28.6	28.6	25.2	23.0	16.7	16.7				15.3									
18.0	28.6	28.6	28.1	24.6	22.7	16.7	16.7				14.9	13.9				10.5				
20.0	26.2	25.5	24.9	24.0	22.4	16.7	16.7	16.7			14.7	13.5				10.3				
22.0	23.0	22.6	22.1	22.0	22.0	16.7	16.7	16.7	14.6		14.4	13.1				10.1	9.5			
24.0	20.3	20.0	19.7	19.6	19.7	16.7	16.7	16.6	14.2	12.9	14.1	12.7	11.3			9.9	9.2			
26.0	18.0	17.8	17.6	17.5	17.6	16.7	16.7	16.1	13.9	12.7	13.7	12.3	11.0			9.7	8.9			
28.0	15.9	15.8	15.7	15.7	15.8	15.4	15.2	15.1	13.6	12.6	13.3	12.0	10.6	9.6		9.5	8.6			
30.0	14.1	14.0	14.0	14.0	14.1	13.7	13.7	13.7	13.3	12.5	12.9	11.7	10.4	9.4	8.6	9.3	8.2	7.0		
32.0	12.4	12.4	12.5	12.5		12.3	12.3	12.4	12.5	12.4	11.9	11.4	10.1	9.2	8.4	9.2	8.0	6.8		
34.0	11.0	11.0	11.1	11.1		11.0	11.0	11.2	11.3	11.5	10.7	10.8	9.8	9.0	8.3	8.8	7.7	6.6	5.7	
36.0	9.6	9.7	9.8	9.8		9.8	9.9	10.0	10.2	10.3	9.7	9.8	9.6	8.8	8.2	8.5	7.4	6.4	5.6	
38.0	8.5	8.5	8.6	8.6		8.7	8.9	9.0	9.2	9.3	8.8	8.9	9.1	8.7	8.1	8.2	7.2	6.2	5.4	5.2
40.0	7.4	7.4	7.5	7.6		7.8	7.9	8.1	8.2		7.9	8.0	8.3	8.5	8.1	7.9	7.0	6.0	5.3	5.2
42.0	6.4	6.5	6.5			6.9	7.0	7.2	7.3		7.1	7.2	7.5	7.7	8.0	7.2	6.8	5.8	5.2	5.1
44.0	5.5	5.5	5.6			6.0	6.2	6.4	6.5		6.3	6.5	6.8	7.0	7.2	6.5	6.6	5.7	5.1	5.0
46.0	4.5	4.7	4.8			5.3	5.4	5.6	5.7		5.6	5.8	6.1	6.3		5.9	6.1	5.5	5.1	5.0
48.0	3.2	3.5	3.6			4.6	4.7	4.9	4.9		5.0	5.2	5.4	5.6		5.3	5.5	5.4	5.1	4.9
50.0	2.0	2.2				3.9	4.0	4.2			4.4	4.6	4.8	5.0		4.8	5.0	5.3	5.0	4.9
54.0						2.5	2.8	2.9			3.3	3.5	3.7	3.8		3.7	4.0	4.3	4.5	
58.0											2.3	2.5	2.7			2.8	3.0	3.3	3.5	
62.0												1.6	1.7			2.0	2.2	2.5	2.6	
66.0																1.5	1.6			
θ(°)	30~ 84.5	31~ 84.5	36~ 84.5	51~ 84.5	66~ 84.5	36~ 84.5	38~ 84.5	39~ 84.5	50~ 84.5	65~ 84.5	38~ 84.5	36~ 84.5	39~ 84.5	54~ 84.5	68~ 84.5	41~ 84.5	40~ 84.5	44~ 84.5	53~ 84.5	70~ 84.5
標準フック	35t					35t					12.2t									
フック重量	950kg					950kg					440kg									
標準巻掛本数	3					2					1									

PS+フルオートラフィングジブ

カウンタウエイト 118t、アウトリガ張出幅 8.0m
PS+50.5mブーム+2.3m+フルオートラフィングジブ

単位:t

ジブ長さ(m) 作業半径 (m)	10.3m オフセット					17.2m オフセット					24.1m オフセット					31.0m オフセット				
	5°	15°	30°	45°	60°	5°	15°	30°	45°	60°	5°	15°	30°	45°	60°	5°	15°	30°	45°	60°
11.0	21.0																			
12.0	21.0																			
14.0	21.0	20.4				15.9														
16.0	21.0	19.0	16.7	15.2		15.9	15.6				12.2									
18.0	19.7	17.8	15.7	14.4	13.6	15.9	14.5				12.2					9.0				
20.0	18.4	16.6	14.8	13.7	13.0	15.5	13.6	11.7			12.2	11.5				9.0				
22.0	17.2	15.7	14.0	13.0	12.4	14.5	12.8	11.1	10.0		12.2	10.9				9.0				
24.0	16.1	14.8	13.3	12.4	11.9	13.5	12.1	10.6	9.6	9.0	11.7	10.2				9.0	8.9			
26.0	15.1	13.9	12.7	11.9	11.5	12.7	11.4	10.0	9.2	8.6	10.9	9.7	8.4			9.0	8.7			
28.0	14.3	13.2	12.1	11.4	11.1	12.0	10.8	9.6	8.8	8.3	10.3	9.1	8.0			9.0	8.3			
30.0	13.2	12.6	11.6	11.0	10.7	11.3	10.2	9.1	8.4	8.0	9.7	8.7	7.6	6.9		8.8	7.8	6.8		
32.0	11.7	11.7	11.1	10.5	10.3	10.7	9.7	8.7	8.1	7.8	9.2	8.2	7.2	6.6	6.2	8.4	7.4	6.5		
34.0	10.3	10.3	10.3	10.2	10.0	10.1	9.3	8.4	7.8	7.5	8.7	7.8	6.9	6.4	5.9	7.9	7.1	6.2		
36.0	9.0	9.1	9.2	9.2		9.2	8.8	8.0	7.5	7.2	8.2	7.4	6.6	6.0	5.7	7.5	6.7	5.9	5.4	
38.0	7.9	8.0	8.0	8.1		8.2	8.2	7.7	7.1	6.9	7.8	7.1	6.3	5.7	5.4	7.1	6.4	5.6	5.1	4.7
40.0	6.8	6.9	7.0	7.1		7.2	7.3	7.3	6.8	6.6	7.3	6.7	5.9	5.4	5.1	6.7	6.1	5.3	4.8	4.4
42.0	5.9	6.0	6.1	6.1		6.3	6.5	6.7	6.5		6.5	6.3	5.6	5.2	4.9	6.4	5.7	5.0	4.5	4.2
44.0	5.0	5.1	5.2	5.2		5.5	5.7	5.9	6.0		5.8	5.9	5.3	4.9	4.7	6.0	5.4	4.7	4.3	4.0
46.0	4.2	4.3	4.4			4.8	5.0	5.1	5.3		5.1	5.3	5.0	4.7	4.5	5.4	5.1	4.5	4.1	3.8
48.0	3.4	3.5	3.6			4.1	4.3	4.5	4.6		4.5	4.7	4.7	4.4	4.3	4.8	4.7	4.2	3.8	3.6
50.0	2.3	2.6	2.9			3.5	3.6	3.8	3.9		3.9	4.1	4.4	4.2		4.3	4.5	4.0	3.6	3.5
54.0						2.3	2.5	2.6			2.8	3.1	3.3	3.5		3.3	3.5	3.5	3.3	3.1
58.0								1.5			1.9	2.1	2.3	2.4		2.4	2.6	2.9	2.9	
62.0																1.6	1.9	2.1	2.3	
66.0																			1.5	
θ (°)	38~ 84.5	39~ 84.5	40~ 84.5	50~ 84.5	63~ 84.5	41~ 84.5	43~ 84.5	39~ 84.5	52~ 84.5	66~ 84.5	44~ 84.5	47~ 84.5	50~ 84.5	52~ 84.5	65~ 84.5	46~ 84.5	50~ 84.5	55~ 84.5	52~ 84.5	68~ 84.5
標準フック	35t										12.2t									
フック重量	950kg										440kg									
標準巻掛本数	2										1									

カウンタウエイト 118t、アウトリガ張出幅 8.0m
PS+55.6mブーム+2.3m+フルオートラフィングジブ

単位:t

ジブ長さ(m) 作業半径 (m)	10.3m オフセット					17.2m オフセット					24.1m オフセット					31.0m オフセット				
	5°	15°	30°	45°	60°	5°	15°	30°	45°	60°	5°	15°	30°	45°	60°	5°	15°	30°	45°	60°
12.0	15.0																			
14.0	15.0	15.0				11.7														
16.0	15.0	15.0	14.5			11.7														
18.0	15.0	15.0	13.5	12.6	11.9	11.7	11.7				8.8									
20.0	15.0	13.9	12.6	11.8	11.3	11.7	11.7				8.8					6.8				
22.0	14.0	13.0	11.9	11.1	10.7	11.7	10.9	9.7			8.8	8.8				6.8				
24.0	13.0	12.1	11.1	10.5	10.1	11.2	10.2	9.1	8.4		8.8	8.8				6.8				
26.0	12.1	11.3	10.5	9.9	9.5	10.5	9.6	8.6	8.0	7.6	8.8	8.7	7.7			6.8	6.8			
28.0	11.3	10.5	9.7	9.2	8.8	9.8	9.0	8.1	7.5	7.1	8.8	8.1	7.2			6.8	6.8			
30.0	10.3	9.7	9.0	8.5	8.2	9.0	8.2	7.5	6.9	6.6	8.4	7.7	6.8	6.3		6.8	6.8			
32.0	9.4	8.9	8.3	7.9	7.6	8.2	7.6	6.9	6.4	6.1	7.7	7.0	6.3	5.8	5.5	6.8	6.5	5.7		
34.0	8.7	8.2	7.6	7.3	7.1	7.5	7.0	6.4	6.0	5.7	7.1	6.5	5.8	5.4	5.1	6.5	5.9	5.3		
36.0	7.9	7.5	7.0	6.8	6.6	6.9	6.4	5.9	5.5	5.3	6.5	6.0	5.4	5.0	4.7	6.0	5.5	4.9	4.5	
38.0	7.3	6.9	6.5	6.3		6.3	5.9	5.4	5.1	4.9	5.9	5.5	5.0	4.6	4.4	5.5	5.0	4.5	4.2	
40.0	6.4	6.3	6.0	5.8		5.7	5.4	5.0	4.7	4.6	5.4	5.0	4.6	4.3	4.1	5.0	4.6	4.2	3.9	3.7
42.0	5.4	5.5	5.5	5.3		5.2	4.9	4.6	4.3	4.2	5.0	4.6	4.2	4.0	3.8	4.6	4.2	3.8	3.6	3.4
44.0	4.6	4.7	4.8	4.8		4.8	4.5	4.2	4.0		4.5	4.2	3.9	3.7	3.5	4.2	3.9	3.5	3.3	3.1
46.0	3.8	3.9	4.0	4.0		4.3	4.1	3.8	3.7		4.1	3.9	3.6	3.4	3.2	3.8	3.5	3.2	3.0	2.9
48.0	3.0	3.1	3.2	3.3		3.7	3.7	3.5	3.4		3.7	3.5	3.3	3.1	3.0	3.5	3.2	3.0	2.8	2.7
50.0	2.4	2.5	2.5			3.0	3.2	3.2	3.1		3.4	3.2	3.0	2.8	2.7	3.1	2.9	2.7	2.5	2.4
54.0						1.9	2.1	2.3	2.3		2.5	2.6	2.4	2.3		2.5	2.4	2.2	2.1	2.0
58.0											1.6	1.8	2.0	1.9		2.0	1.9	1.8	1.7	
62.0																		1.5		
θ (°)	44~ 84.5	45~ 84.5	46~ 84.5	50~ 84.5	64~ 84.5	46~ 84.5	48~ 84.5	51~ 84.5	52~ 84.5	66~ 84.5	49~ 84.5	52~ 84.5	55~ 84.5	57~ 84.5	67~ 84.5	55~ 84.5	54~ 84.5	62~ 84.5	66~ 84.5	71~ 84.5
標準フック	35t										12.2t									
フック重量	950kg										440kg									
標準巻掛本数	2										1									

カウンタウエイト 118t、アウトリガ張出幅 8.0m
PS+60.0mブーム+2.3m+フルオートラフィングジブ

単位:t

ジブ長さ(m) 作業半径 (m)	10.3m オフセット					17.2m オフセット					24.1m オフセット					31.0m オフセット							
	5°	15°	30°	45°	60°	5°	15°	30°	45°	60°	5°	15°	30°	45°	60°	5°	15°	30°	45°	60°			
14.0	11.5					8.7																	
16.0	11.5	11.5				8.7	8.7								6.8								
18.0	11.5	11.5	11.5	11.5		8.7	8.7							6.8									
20.0	11.5	11.5	11.5	11.0	10.5	8.7	8.7							6.8					5.3				
22.0	11.5	11.5	11.0	10.4	9.9	8.7	8.7	8.7						6.8	6.8				5.3				
24.0	11.5	11.3	10.2	9.5	9.2	8.7	8.7	8.4						6.8	6.8				5.3				
26.0	11.2	10.4	9.3	8.7	8.4	8.7	8.7	7.6	7.0	6.6				6.8	6.8				5.3	5.3			
28.0	10.3	9.4	8.5	7.9	7.7	8.7	8.0	7.0	6.4	6.1				6.8	6.8	5.9			5.3	5.3			
30.0	9.2	8.5	7.7	7.3	7.1	8.1	7.2	6.4	5.9	5.6				6.8	6.2	5.4			5.3	5.3			
32.0	8.3	7.6	7.0	6.6	6.5	7.3	6.6	5.8	5.4	5.2				6.3	5.6	4.9	4.5		5.3	5.0			
34.0	7.4	6.9	6.3	6.0	5.9	6.6	5.9	5.3	4.9	4.8				5.7	5.1	4.5	4.1	3.9	5.1	4.5	4.0		
36.0	6.6	6.2	5.7	5.5	5.4	5.9	5.4	4.8	4.5	4.4				5.1	4.6	4.1	3.8	3.6	4.6	4.1	3.6		
38.0	5.9	5.5	5.1	4.9	4.9	5.3	4.8	4.4	4.1	4.0				4.6	4.2	3.7	3.5	3.3	4.2	3.7	3.3	3.0	
40.0	5.3	5.0	4.6	4.5		4.7	4.3	4.0	3.7	3.7				4.1	3.8	3.4	3.1	3.0	3.7	3.4	3.0	2.8	
42.0	4.4	4.4	4.1	4.0		4.2	3.9	3.6	3.4	3.3				3.7	3.4	3.0	2.8	2.8	3.3	3.0	2.7	2.5	2.4
44.0	3.6	3.7	3.7	3.6		3.7	3.5	3.2	3.0	3.0				3.3	3.0	2.7	2.6	2.5	3.0	2.7	2.4	2.3	2.2
46.0	2.8	2.9	3.1	3.1		3.3	3.1	2.8	2.7					2.9	2.7	2.4	2.3	2.3	2.6	2.4	2.2	2.0	2.0
48.0	2.1	2.2	2.4	2.4		2.9	2.7	2.5	2.4					2.6	2.4	2.2	2.1	2.0	2.3	2.1	1.9	1.8	1.8
50.0		1.6	1.7	1.7		2.2	2.4	2.2	2.1					2.2	2.1	1.9	1.8	1.8	2.0	1.9	1.7	1.6	1.6
54.0								1.6	1.6					1.6	1.5				1.5				
θ(°)	51~	50~	51~	52~	65~	55~	57~	55~	56~	67~	56~	58~	65~	68~	69~	60~	66~	71~	75~	77~			
	84.5	84.5	84.5	84.5	84.5	84.5	84.5	84.5	84.5	84.5	84.5	84.5	84.5	84.5	84.5	84.5	84.5	84.5	84.5	84.5	84.5	84.5	84.5
標準フック												12.2t											
フック重量												440kg											
標準巻掛本数												1											

PS+FLJ

カウンタウエイト 98t、アウトリガ張出幅 8.5m
PS+40.4mブーム+2.3m+フルオートラフィングジブ

単位:t

ジブ長さ(m) 作業半径 (m)	10.3m オフセット					17.2m オフセット					24.1m オフセット					31.0m オフセット							
	5°	15°	30°	45°	60°	5°	15°	30°	45°	60°	5°	15°	30°	45°	60°	5°	15°	30°	45°	60°			
9.0	37.6																						
10.0	37.6					16.7																	
11.0	37.6	37.6				16.7																	
12.0	37.6	37.6				16.7																	
14.0	37.6	37.6	30.3	25.6		16.7	16.7							16.4									
16.0	36.3	35.0	29.0	24.8	22.8	16.7	16.7							16.0					10.9				
18.0	31.7	30.8	27.8	24.2	22.4	16.7	16.7	16.7						15.6	14.0				10.9				
20.0	27.9	27.2	26.6	23.5	22.1	16.7	16.7	16.7	14.9					15.2	13.6				10.7				
22.0	24.6	24.2	23.7	23.0	21.9	16.7	16.7	16.7	14.5	13.1				14.7	13.1	11.6			10.5	9.7			
24.0	21.8	21.5	21.2	21.1	21.2	16.7	16.7	16.3	14.1	12.9	14.2			12.7	11.3				10.3	9.3			
26.0	19.4	19.2	19.0	18.9	19.0	16.7	16.7	15.7	13.7	12.7	13.7			12.3	11.0	9.8			10.0	8.9			
28.0	17.2	17.1	17.0	17.0	17.1	16.6	16.4	15.2	13.4	12.5	13.2			12.0	10.6	9.6			9.8	8.5	7.2		
30.0	15.3	15.3	15.2	15.2		15.0	14.9	14.7	13.1	12.4	12.8			11.7	10.3	9.3	8.5		9.5	8.2	7.0		
32.0	13.6	13.6	13.6	13.7		13.5	13.4	13.5	12.8	12.3	12.4			11.4	10.1	9.1	8.4		9.1	7.9	6.7		
34.0	11.7	12.1	12.2	12.2		12.1	12.1	12.2	12.3	12.2	11.8			11.1	9.8	8.9	8.3		8.7	7.6	6.5	5.7	
36.0	9.5	10.1	10.7	10.9		10.9	11.0	11.1	11.2	11.3	10.7			10.7	9.5	8.8	8.2		8.4	7.4	6.3	5.6	5.3
38.0	7.5	8.0	8.5	8.7		9.8	9.9	10.0	10.1					9.7	9.8	9.3	8.6	8.1	8.0	7.1	6.1	5.4	5.2
40.0	5.7	6.2	6.6			8.8	8.9	9.0	9.1					8.8	8.9	9.1	8.4	8.1	7.7	6.9	5.9	5.3	5.1
42.0	4.2	4.5	4.8			7.2	7.9	8.1	8.2					8.0	8.1	8.3	8.3	8.0	7.5	6.7	5.8	5.2	5.1
44.0	2.7	3.0	3.2			5.8	6.5	7.2	7.3					7.2	7.3	7.6	7.8		7.2	6.5	5.6	5.2	5.0
46.0						4.4	5.1	5.7						6.5	6.6	6.9	7.1		6.7	6.3	5.5	5.1	5.0
48.0						3.2	3.8	4.3						5.5	6.0	6.2	6.4		6.1	6.1	5.3	5.1	5.0
50.0						2.1	2.6	2.9						4.4	5.2	5.6	5.7		5.5	5.7	5.2	5.0	4.9
54.0														2.4	3.0	3.7			4.4	4.7	5.0	4.9	
58.0																1.5			2.7	3.5	4.0	4.1	
62.0																			1.8	2.5			
θ(°)	33~	35~	36~	48~	64~	35~	37~	39~	52~	65~	38~	42~	37~	53~	66~	41~	39~	44~	53~	66~			
	84.5	84.5	84.5	84.5	84.5	84.5	84.5	84.5	84.5	84.5	84.5	84.5	84.5	84.5	84.5	84.5	84.5	84.5	84.5	84.5	84.5	84.5	84.5
標準フック												35t											
フック重量												950kg											
標準巻掛本数												2											

PS+フルオートラフィングジブ

カウンタウエイト 98t、アウトリガ張出幅 8.5m
PS+45.4mブーム+2.3m+フルオートラフィングジブ

単位:t

ジブ長さ(m) 作業半径 (m)	10.3m オフセット					17.2m オフセット					24.1m オフセット					31.0m オフセット				
	5°	15°	30°	45°	60°	5°	15°	30°	45°	60°	5°	15°	30°	45°	60°	5°	15°	30°	45°	60°
10.0	28.6																			
11.0	28.6																			
12.0	28.6	28.6				16.7														
14.0	28.6	28.6	28.6			16.7					15.5									
16.0	28.6	28.6	28.6	25.2	23.0	16.7	16.7				15.3									
18.0	28.6	28.6	28.1	24.6	22.7	16.7	16.7				14.9	13.9				10.5				
20.0	26.2	25.5	24.9	24.0	22.4	16.7	16.7	16.7			14.7	13.5				10.3				
22.0	23.0	22.6	22.1	22.0	22.0	16.7	16.7	16.7	14.6		14.4	13.1				10.1	9.5			
24.0	20.3	20.0	19.7	19.6	19.7	16.7	16.7	16.6	14.2	12.9	14.1	12.7	11.3			9.9	9.2			
26.0	18.0	17.8	17.6	17.5	17.6	16.7	16.7	16.1	13.9	12.7	13.7	12.3	11.0			9.7	8.9			
28.0	15.9	15.8	15.7	15.7	15.8	15.4	15.2	15.1	13.6	12.6	13.3	12.0	10.6	9.6		9.5	8.6			
30.0	14.1	14.0	14.0	14.0	14.1	13.7	13.7	13.7	13.3	12.5	12.9	11.7	10.4	9.4	8.6	9.3	8.2	7.0		
32.0	12.4	12.4	12.5	12.5		12.3	12.3	12.4	12.5	12.4	11.9	11.4	10.1	9.2	8.4	9.2	8.0	6.8		
34.0	11.0	11.0	11.1	11.1		11.0	11.0	11.2	11.3	11.5	10.7	10.8	9.8	9.0	8.3	8.8	7.7	6.6	5.7	
36.0	9.6	9.7	9.8	9.8		9.8	9.9	10.0	10.2	10.3	9.7	9.8	9.6	8.8	8.2	8.5	7.4	6.4	5.6	
38.0	7.7	8.3	8.6	8.6		8.7	8.9	9.0	9.2	9.3	8.8	8.9	9.1	8.7	8.1	8.2	7.2	6.2	5.4	5.2
40.0	6.0	6.5	7.0	7.2		7.8	7.9	8.1	8.2		7.9	8.0	8.3	8.5	8.1	7.9	7.0	6.0	5.3	5.2
42.0	4.4	4.9	5.3			6.9	7.0	7.2	7.3		7.1	7.2	7.5	7.7	8.0	7.2	6.8	5.8	5.2	5.1
44.0	3.0	3.4	3.7			5.7	6.2	6.4	6.5		6.3	6.5	6.8	7.0	7.2	6.5	6.6	5.7	5.1	5.0
46.0	1.7	2.0	2.3			4.4	5.1	5.6	5.7		5.6	5.8	6.1	6.3		5.9	6.1	5.5	5.1	5.0
48.0						3.2	3.8	4.5	4.8		5.0	5.2	5.4	5.6		5.3	5.5	5.4	5.1	4.9
50.0						2.1	2.7	3.2			4.2	4.6	4.8	5.0		4.8	5.0	5.3	5.0	4.9
54.0											2.2	3.0	3.7	3.8		3.7	4.0	4.3	4.5	
58.0													1.8			2.5	3.0	3.3	3.5	
62.0																1.7	2.5	2.6		
θ(°)	38~ 84.5	39~ 84.5	40~ 84.5	51~ 84.5	66~ 84.5	42~ 84.5	44~ 84.5	46~ 84.5	50~ 84.5	65~ 84.5	44~ 84.5	48~ 84.5	46~ 84.5	54~ 84.5	68~ 84.5	46~ 84.5	46~ 84.5	50~ 84.5	53~ 84.5	70~ 84.5
標準フック	35t					35t					35t					12.2t				
フック重量	950kg					950kg					950kg					440kg				
標準巻掛本数	3					2					1									

カウンタウエイト 98t、アウトリガ張出幅 8.5m
PS+50.5mブーム+2.3m+フルオートラフィングジブ

単位:t

ジブ長さ(m) 作業半径 (m)	10.3m オフセット					17.2m オフセット					24.1m オフセット					31.0m オフセット				
	5°	15°	30°	45°	60°	5°	15°	30°	45°	60°	5°	15°	30°	45°	60°	5°	15°	30°	45°	60°
11.0	21.0																			
12.0	21.0																			
14.0	21.0	20.4				15.9														
16.0	21.0	19.0	16.7	15.2		15.9	15.6				12.2									
18.0	19.7	17.8	15.7	14.4	13.6	15.9	14.5				12.2					9.0				
20.0	18.4	16.6	14.8	13.7	13.0	15.5	13.6	11.7			12.2	11.5			9.0					
22.0	17.2	15.7	14.0	13.0	12.4	14.5	12.8	11.1	10.0		12.2	10.9			9.0					
24.0	16.1	14.8	13.3	12.4	11.9	13.5	12.1	10.6	9.6	9.0	11.7	10.2			9.0	8.9				
26.0	15.1	13.9	12.7	11.9	11.5	12.7	11.4	10.0	9.2	8.6	10.9	9.7	8.4		9.0	8.7				
28.0	14.3	13.2	12.1	11.4	11.1	12.0	10.8	9.6	8.8	8.3	10.3	9.1	8.0		9.0	8.3				
30.0	13.2	12.6	11.6	11.0	10.7	11.3	10.2	9.1	8.4	8.0	9.7	8.7	7.6	6.9	8.8	7.8	6.8			
32.0	11.7	11.7	11.1	10.5	10.3	10.7	9.7	8.7	8.1	7.8	9.2	8.2	7.2	6.6	8.4	7.4	6.5			
34.0	10.3	10.3	10.3	10.2	10.0	10.1	9.3	8.4	7.8	7.5	8.7	7.8	6.9	6.4	7.9	7.1	6.2			
36.0	9.0	9.1	9.2	9.2		9.2	8.8	8.0	7.5	7.2	8.2	7.4	6.6	6.0	7.5	6.7	5.9	5.4		
38.0	7.9	8.0	8.0	8.1		8.2	8.2	7.7	7.1	6.9	7.8	7.1	6.3	5.7	7.1	6.4	5.6	5.1	4.7	
40.0	6.2	6.8	7.0	7.1		7.2	7.3	7.3	6.8	6.6	7.3	6.7	5.9	5.4	6.7	6.1	5.3	4.8	4.4	
42.0	4.7	5.2	5.7	5.9		6.3	6.5	6.7	6.5		6.5	6.3	5.6	5.2	6.4	5.7	5.0	4.5	4.2	
44.0	3.3	3.7	4.2	4.3		5.5	5.7	5.9	6.0		5.8	5.9	5.3	4.9	6.0	5.4	4.7	4.3	4.0	
46.0	2.0	2.4	2.7			4.6	5.0	5.1	5.3		5.1	5.3	5.0	4.7	5.4	5.1	4.5	4.1	3.8	
48.0			1.5			3.4	4.1	4.5	4.6		4.5	4.7	4.7	4.4	4.3	4.8	4.7	4.2	3.8	3.6
50.0						2.3	2.9	3.7	3.9		3.9	4.1	4.4	4.2		4.3	4.5	4.0	3.6	3.5
54.0											2.3	3.1	3.3	3.5		3.3	3.5	3.5	3.3	3.1
58.0													2.1	2.4		2.4	2.6	2.9	2.9	
62.0																1.8	2.1	2.3		
θ(°)	44~ 84.5	46~ 84.5	44~ 84.5	50~ 84.5	63~ 84.5	46~ 84.5	49~ 84.5	51~ 84.5	52~ 84.5	66~ 84.5	48~ 84.5	52~ 84.5	50~ 84.5	52~ 84.5	65~ 84.5	50~ 84.5	50~ 84.5	55~ 84.5	58~ 84.5	68~ 84.5
標準フック	35t					35t					12.2t					12.2t				
フック重量	950kg					950kg					440kg					440kg				
標準巻掛本数	2					2					1					1				

カウンタウエイト 98t、アウトリガ張出幅 8.5m
PS+55.6mブーム+2.3m+フルオートラフィングジブ

単位:t

ジブ長さ(m) 作業半径 (m)	10.3m オフセット					17.2m オフセット					24.1m オフセット					31.0m オフセット				
	5°	15°	30°	45°	60°	5°	15°	30°	45°	60°	5°	15°	30°	45°	60°	5°	15°	30°	45°	60°
12.0	15.0																			
14.0	15.0	15.0				11.7														
16.0	15.0	15.0	14.5			11.7														
18.0	15.0	15.0	13.5	12.6	11.9	11.7	11.7				8.8									
20.0	15.0	13.9	12.6	11.8	11.3	11.7	11.7				8.8					6.8				
22.0	14.0	13.0	11.9	11.1	10.7	11.7	10.9	9.7			8.8	8.8				6.8				
24.0	13.0	12.1	11.1	10.5	10.1	11.2	10.2	9.1	8.4		8.8	8.8				6.8				
26.0	12.1	11.3	10.5	9.9	9.5	10.5	9.6	8.6	8.0	7.6	8.8	8.7	7.7		6.8	6.8				
28.0	11.3	10.5	9.7	9.2	8.8	9.8	9.0	8.1	7.5	7.1	8.8	8.1	7.2		6.8	6.8				
30.0	10.3	9.7	9.0	8.5	8.2	9.0	8.2	7.5	6.9	6.6	8.4	7.7	6.8	6.3	6.8	6.8				
32.0	9.4	8.9	8.3	7.9	7.6	8.2	7.6	6.9	6.4	6.1	7.7	7.0	6.3	5.8	5.5	6.8	6.5	5.7		
34.0	8.7	8.2	7.6	7.3	7.1	7.5	7.0	6.4	6.0	5.7	7.1	6.5	5.8	5.4	5.1	6.5	5.9	5.3		
36.0	7.9	7.5	7.0	6.8	6.6	6.9	6.4	5.9	5.5	5.3	6.5	6.0	5.4	5.0	4.7	6.0	5.5	4.9	4.5	
38.0	7.3	6.9	6.5	6.3		6.3	5.9	5.4	5.1	4.9	5.9	5.5	5.0	4.6	4.4	5.5	5.0	4.5	4.2	
40.0	6.4	6.3	6.0	5.8		5.7	5.4	5.0	4.7	4.6	5.4	5.0	4.6	4.3	4.1	5.0	4.6	4.2	3.9	3.7
42.0	5.2	5.5	5.5	5.3		5.2	4.9	4.6	4.3	4.2	5.0	4.6	4.2	4.0	3.8	4.6	4.2	3.8	3.6	3.4
44.0	3.8	4.3	4.8	4.8		4.8	4.5	4.2	4.0		4.5	4.2	3.9	3.7	3.5	4.2	3.9	3.5	3.3	3.1
46.0	2.5	3.0	3.4	3.6		4.3	4.1	3.8	3.7		4.1	3.9	3.6	3.4	3.2	3.8	3.5	3.2	3.0	2.9
48.0			2.1	2.2		3.5	3.7	3.5	3.4		3.7	3.5	3.3	3.1	3.0	3.5	3.2	3.0	2.8	2.7
50.0						2.4	3.1	3.2	3.1		3.4	3.2	3.0	2.8	2.7	3.1	2.9	2.7	2.5	2.4
54.0											2.5	2.6	2.4	2.3		2.5	2.4	2.2	2.1	2.0
58.0													2.0	1.9		2.0	1.9	1.8	1.7	
θ(°)	49~ 84.5	50~ 84.5	49~ 84.5	50~ 84.5	64~ 84.5	51~ 84.5	53~ 84.5	56~ 84.5	57~ 84.5	66~ 84.5	53~ 84.5	56~ 84.5	55~ 84.5	57~ 84.5	67~ 84.5	55~ 84.5	58~ 84.5	62~ 84.5	66~ 84.5	71~ 84.5
標準フック	35t					12.2t					12.2t									
フック重量	950kg					440kg					440kg									
標準巻掛本数	2					1					1									

PS+FLJ

カウンタウエイト 98t、アウトリガ張出幅 8.5m
PS+60.0mブーム+2.3m+フルオートラフィングジブ

単位:t

ジブ長さ(m) 作業半径 (m)	10.3m オフセット					17.2m オフセット					24.1m オフセット					31.0m オフセット				
	5°	15°	30°	45°	60°	5°	15°	30°	45°	60°	5°	15°	30°	45°	60°	5°	15°	30°	45°	60°
14.0	11.5																			
16.0	11.5	11.5				8.7														
18.0	11.5	11.5	11.5	11.5		8.7	8.7				6.8									
20.0	11.5	11.5	11.5	11.0	10.5	8.7	8.7				6.8					5.3				
22.0	11.5	11.5	11.0	10.4	9.9	8.7	8.7	8.7			6.8	6.8				5.3				
24.0	11.5	11.3	10.2	9.5	9.2	8.7	8.7	8.4			6.8	6.8				5.3				
26.0	11.2	10.4	9.3	8.7	8.4	8.7	8.7	7.6	7.0	6.6	6.8	6.8				5.3	5.3			
28.0	10.3	9.4	8.5	7.9	7.7	8.7	8.0	7.0	6.4	6.1	6.8	6.8	5.9			5.3	5.3			
30.0	9.2	8.5	7.7	7.3	7.1	8.1	7.2	6.4	5.9	5.6	6.8	6.2	5.4			5.3	5.3			
32.0	8.3	7.6	7.0	6.6	6.5	7.3	6.6	5.8	5.4	5.2	6.3	5.6	4.9	4.5		5.3	5.0			
34.0	7.4	6.9	6.3	6.0	5.9	6.6	5.9	5.3	4.9	4.8	5.7	5.1	4.5	4.1	3.9	5.1	4.5	4.0		
36.0	6.6	6.2	5.7	5.5	5.4	5.9	5.4	4.8	4.5	4.4	5.1	4.6	4.1	3.8	3.6	4.6	4.1	3.6		
38.0	5.9	5.5	5.1	4.9	4.9	5.3	4.8	4.4	4.1	4.0	4.6	4.2	3.7	3.5	3.3	4.2	3.7	3.3	3.0	
40.0	5.3	5.0	4.6	4.5		4.7	4.3	4.0	3.7	3.7	4.1	3.8	3.4	3.1	3.0	3.7	3.4	3.0	2.8	
42.0	4.4	4.4	4.1	4.0		4.2	3.9	3.6	3.4	3.3	3.7	3.4	3.0	2.8	2.8	3.3	3.0	2.7	2.5	2.4
44.0	3.6	3.7	3.7	3.6		3.7	3.5	3.2	3.0	3.0	3.3	3.0	2.7	2.6	2.5	3.0	2.7	2.4	2.3	2.2
46.0			3.1	3.1		3.3	3.1	2.8	2.7		2.9	2.7	2.4	2.3	2.3	2.6	2.4	2.2	2.0	2.0
48.0						2.9	2.7	2.5	2.4		2.6	2.4	2.2	2.1	2.0	2.3	2.1	1.9	1.8	1.8
50.0							2.4	2.2	2.1		2.2	2.1	1.9	1.8	1.8	2.0	1.9	1.7	1.6	1.6
54.0													1.5			1.5				
θ(°)	55~ 84.5	56~ 84.5	56~ 84.5	56~ 84.5	65~ 84.5	57~ 84.5	57~ 84.5	59~ 84.5	60~ 84.5	67~ 84.5	59~ 84.5	58~ 84.5	65~ 84.5	68~ 84.5	69~ 84.5	60~ 84.5	66~ 84.5	71~ 84.5	75~ 84.5	77~ 84.5
標準フック	12.2t					12.2t					12.2t									
フック重量	440kg					440kg					440kg									
標準巻掛本数	1					1					1									

PS+フルオートラフィングジブ

カウンタウエイト 98t、アウトリガ張出幅 8.0m

PS+40.4mブーム+2.3m+フルオートラフィングジブ

単位:t

ジブ長さ(m) 作業半径 (m)	10.3m オフセット					17.2m オフセット					24.1m オフセット					31.0m オフセット				
	5°	15°	30°	45°	60°	5°	15°	30°	45°	60°	5°	15°	30°	45°	60°	5°	15°	30°	45°	60°
9.0	37.6																			
10.0	37.6					16.7														
11.0	37.6	37.6				16.7														
12.0	37.6	37.6				16.7														
14.0	37.6	37.6	30.3	25.6		16.7	16.7				16.4									
16.0	36.3	35.0	29.0	24.8	22.8	16.7	16.7				16.0					10.9				
18.0	31.7	30.8	27.8	24.2	22.4	16.7	16.7	16.7			15.6	14.0				10.9				
20.0	27.9	27.2	26.6	23.5	22.1	16.7	16.7	16.7	14.9		15.2	13.6				10.7				
22.0	24.6	24.2	23.7	23.0	21.9	16.7	16.7	16.7	14.5	13.1	14.7	13.1	11.6			10.5	9.7			
24.0	21.8	21.5	21.2	21.1	21.2	16.7	16.7	16.3	14.1	12.9	14.2	12.7	11.3			10.3	9.3			
26.0	19.4	19.2	19.0	18.9	19.0	16.7	16.7	15.7	13.7	12.7	13.7	12.3	11.0	9.8		10.0	8.9			
28.0	17.2	17.1	17.0	17.0	17.1	16.6	16.4	15.2	13.4	12.5	13.2	12.0	10.6	9.6		9.8	8.5	7.2		
30.0	15.3	15.3	15.2	15.2		15.0	14.9	14.7	13.1	12.4	12.8	11.7	10.3	9.3	8.5	9.5	8.2	7.0		
32.0	13.4	13.6	13.6	13.7		13.5	13.4	13.5	12.8	12.3	12.4	11.4	10.1	9.1	8.4	9.1	7.9	6.7		
34.0	10.9	11.6	12.2	12.2		12.1	12.1	12.2	12.3	12.2	11.8	11.1	9.8	8.9	8.3	8.7	7.6	6.5	5.7	
36.0	8.7	9.3	10.0	10.2		10.9	11.0	11.1	11.2	11.3	10.7	10.7	9.5	8.8	8.2	8.4	7.4	6.3	5.6	5.3
38.0	6.7	7.3	7.8	7.9		9.8	9.9	10.0	10.1		9.7	9.8	9.3	8.6	8.1	8.0	7.1	6.1	5.4	5.2
40.0	5.0	5.4	5.8			8.1	8.9	9.0	9.1		8.8	8.9	9.1	8.4	8.1	7.7	6.9	5.9	5.3	5.1
42.0	3.4	3.8	4.1			6.5	7.4	8.1	8.2		8.0	8.1	8.3	8.3	8.0	7.5	6.7	5.8	5.2	5.1
44.0			2.5			5.1	5.8	6.6	7.0		7.2	7.3	7.6	7.8		7.2	6.5	5.6	5.2	5.0
46.0						3.8	4.4	5.1			6.1	6.6	6.9	7.1		6.7	6.3	5.5	5.1	5.0
48.0						2.6	3.2	3.7			4.9	5.8	6.2	6.4		6.1	6.1	5.3	5.1	5.0
50.0						1.5	2.0	2.3			3.8	4.6	5.6	5.7		5.5	5.7	5.2	5.0	4.9
54.0											1.9	2.5	3.2			3.9	4.7	5.0	4.9	
58.0																2.2	3.0	4.0	4.1	
62.0																		2.0		
θ(°)	37~ 84.5	39~ 84.5	36~ 84.5	48~ 84.5	64~ 84.5	35~ 84.5	37~ 84.5	39~ 84.5	52~ 84.5	65~ 84.5	38~ 84.5	42~ 84.5	45~ 84.5	53~ 84.5	66~ 84.5	41~ 84.5	45~ 84.5	44~ 84.5	53~ 84.5	66~ 84.5
標準フック											35t					12.2t				
フック重量	80t										950kg					440kg				
標準巻掛本数	4										2					1				

カウンタウエイト 98t、アウトリガ張出幅 8.0m

PS+45.4mブーム+2.3m+フルオートラフィングジブ

単位:t

ジブ長さ(m) 作業半径 (m)	10.3m オフセット					17.2m オフセット					24.1m オフセット					31.0m オフセット				
	5°	15°	30°	45°	60°	5°	15°	30°	45°	60°	5°	15°	30°	45°	60°	5°	15°	30°	45°	60°
10.0	28.6																			
11.0	28.6																			
12.0	28.6	28.6				16.7														
14.0	28.6	28.6	28.6			16.7					15.5									
16.0	28.6	28.6	28.6	25.2	23.0	16.7	16.7				15.3									
18.0	28.6	28.6	28.1	24.6	22.7	16.7	16.7				14.9	13.9				10.5				
20.0	26.2	25.5	24.9	24.0	22.4	16.7	16.7	16.7			14.7	13.5				10.3				
22.0	23.0	22.6	22.1	22.0	22.0	16.7	16.7	16.7	14.6		14.4	13.1				10.1	9.5			
24.0	20.3	20.0	19.7	19.6	19.7	16.7	16.7	16.6	14.2	12.9	14.1	12.7	11.3			9.9	9.2			
26.0	18.0	17.8	17.6	17.5	17.6	16.7	16.7	16.1	13.9	12.7	13.7	12.3	11.0			9.7	8.9			
28.0	15.9	15.8	15.7	15.7	15.8	15.4	15.2	15.1	13.6	12.6	13.3	12.0	10.6	9.6		9.5	8.6			
30.0	14.1	14.0	14.0	14.0	14.1	13.7	13.7	13.7	13.3	12.5	12.9	11.7	10.4	9.4	8.6	9.3	8.2	7.0		
32.0	12.4	12.4	12.5	12.5		12.3	12.3	12.4	12.5	12.4	11.9	11.4	10.1	9.2	8.4	9.2	8.0	6.8		
34.0	11.0	11.0	11.1	11.1		11.0	11.0	11.2	11.3	11.5	10.7	10.8	9.8	9.0	8.3	8.8	7.7	6.6	5.7	
36.0	8.9	9.6	9.8	9.8		9.8	9.9	10.0	10.2	10.3	9.7	9.8	9.6	8.8	8.2	8.5	7.4	6.4	5.6	
38.0	7.0	7.6	8.2	8.5		8.7	8.9	9.0	9.2	9.3	8.8	8.9	9.1	8.7	8.1	8.2	7.2	6.2	5.4	5.2
40.0	5.2	5.8	6.3	6.5		7.8	7.9	8.1	8.2		7.9	8.0	8.3	8.5	8.1	7.9	7.0	6.0	5.3	5.2
42.0	3.7	4.1	4.6			6.5	7.0	7.2	7.3		7.1	7.2	7.5	7.7	8.0	7.2	6.8	5.8	5.2	5.1
44.0	2.3	2.7	3.0			5.0	5.9	6.4	6.5		6.3	6.5	6.8	7.0	7.2	6.5	6.6	5.7	5.1	5.0
46.0			1.6			3.7	4.5	5.3	5.7		5.6	5.8	6.1	6.3		5.9	6.1	5.5	5.1	5.0
48.0						2.6	3.2	3.9	4.2		4.7	5.2	5.4	5.6		5.3	5.5	5.4	5.1	4.9
50.0						1.5	2.1	2.6			3.6	4.5	4.8	5.0		4.8	5.0	5.3	5.0	4.9
54.0											1.7	2.4	3.3	3.7		3.6	4.0	4.3	4.5	
58.0																1.9	2.8	3.3	3.5	
62.0																		2.1	2.5	
θ(°)	41~ 84.5	43~ 84.5	40~ 84.5	51~ 84.5	66~ 84.5	42~ 84.5	44~ 84.5	46~ 84.5	50~ 84.5	65~ 84.5	44~ 84.5	48~ 84.5	52~ 84.5	54~ 84.5	68~ 84.5	46~ 84.5	50~ 84.5	50~ 84.5	53~ 84.5	70~ 84.5
標準フック											35t					12.2t				
フック重量	950kg										950kg					440kg				
標準巻掛本数	3										2					1				

カウンタウエイト 98t、アウトリガ張出幅 8.0m

PS+50.5mブーム+2.3m+フルオートラフィングジブ

単位:t

ジブ長さ(m) 作業半径 (m)	10.3m オフセット					17.2m オフセット					24.1m オフセット					31.0m オフセット					
	5°	15°	30°	45°	60°	5°	15°	30°	45°	60°	5°	15°	30°	45°	60°	5°	15°	30°	45°	60°	
11.0	21.0																				
12.0	21.0																				
14.0	21.0	20.4				15.9															
16.0	21.0	19.0	16.7	15.2		15.9	15.6				12.2										
18.0	19.7	17.8	15.7	14.4	13.6	15.9	14.5				12.2					9.0					
20.0	18.4	16.6	14.8	13.7	13.0	15.5	13.6	11.7			12.2	11.5				9.0					
22.0	17.2	15.7	14.0	13.0	12.4	14.5	12.8	11.1	10.0		12.2	10.9				9.0					
24.0	16.1	14.8	13.3	12.4	11.9	13.5	12.1	10.6	9.6	9.0	11.7	10.2				9.0	8.9				
26.0	15.1	13.9	12.7	11.9	11.5	12.7	11.4	10.0	9.2	8.6	10.9	9.7	8.4			9.0	8.7				
28.0	14.3	13.2	12.1	11.4	11.1	12.0	10.8	9.6	8.8	8.3	10.3	9.1	8.0			9.0	8.3				
30.0	13.2	12.6	11.6	11.0	10.7	11.3	10.2	9.1	8.4	8.0	9.7	8.7	7.6	6.9		8.8	7.8	6.8			
32.0	11.7	11.7	11.1	10.5	10.3	10.7	9.7	8.7	8.1	7.8	9.2	8.2	7.2	6.6	6.2	8.4	7.4	6.5			
34.0	10.3	10.3	10.3	10.2	10.0	10.1	9.3	8.4	7.8	7.5	8.7	7.8	6.9	6.4	5.9	7.9	7.1	6.2			
36.0	9.0	9.1	9.2	9.2		9.2	8.8	8.0	7.5	7.2	8.2	7.4	6.6	6.0	5.7	7.5	6.7	5.9	5.4		
38.0	7.2	7.9	8.0	8.1		8.2	8.2	7.7	7.1	6.9	7.8	7.1	6.3	5.7	5.4	7.1	6.4	5.6	5.1	4.7	
40.0	5.5	6.1	6.7	7.0		7.2	7.3	7.3	6.8	6.6	7.3	6.7	5.9	5.4	5.1	6.7	6.1	5.3	4.8	4.4	
42.0	4.0	4.5	5.0	5.2		6.3	6.5	6.7	6.5		6.5	6.3	5.6	5.2	4.9	6.4	5.7	5.0	4.5	4.2	
44.0	2.6	3.0	3.5	3.6		5.2	5.7	5.9	6.0		5.8	5.9	5.3	4.9	4.7	6.0	5.4	4.7	4.3	4.0	
46.0		1.7	2.1			3.9	4.7	5.1	5.3		5.1	5.3	5.0	4.7	4.5	5.4	5.1	4.5	4.1	3.8	
48.0						2.8	3.5	4.3	4.6		4.5	4.7	4.7	4.4	4.3	4.8	4.7	4.2	3.8	3.6	
50.0							2.3	3.1	3.4		3.6	4.1	4.4	4.2		4.3	4.5	4.0	3.6	3.5	
54.0												2.5	3.3	3.5		3.3	3.5	3.5	3.3	3.1	
58.0																	2.6	2.9	2.9		
62.0																		2.1	2.3		
θ(°)	47~ 84.5	46~ 84.5	47~ 84.5	50~ 84.5	63~ 84.5	48~ 84.5	49~ 84.5	51~ 84.5	52~ 84.5	66~ 84.5	52~ 84.5	52~ 84.5	55~ 84.5	57~ 84.5	65~ 84.5	54~ 84.5	54~ 84.5	55~ 84.5	58~ 84.5	68~ 84.5	
標準フック						35t					12.2t										
フック重量						950kg					440kg										
標準巻掛本数						2					1										

PS+FLJ

カウンタウエイト 98t、アウトリガ張出幅 8.0m

PS+55.6mブーム+2.3m+フルオートラフィングジブ

単位:t

ジブ長さ(m) 作業半径 (m)	10.3m オフセット					17.2m オフセット					24.1m オフセット					31.0m オフセット					
	5°	15°	30°	45°	60°	5°	15°	30°	45°	60°	5°	15°	30°	45°	60°	5°	15°	30°	45°	60°	
12.0	15.0																				
14.0	15.0	15.0				11.7															
16.0	15.0	15.0	14.5			11.7															
18.0	15.0	15.0	13.5	12.6	11.9	11.7	11.7				8.8										
20.0	15.0	13.9	12.6	11.8	11.3	11.7	11.7				8.8					6.8					
22.0	14.0	13.0	11.9	11.1	10.7	11.7	10.9	9.7			8.8	8.8				6.8					
24.0	13.0	12.1	11.1	10.5	10.1	11.2	10.2	9.1	8.4		8.8	8.8				6.8					
26.0	12.1	11.3	10.5	9.9	9.5	10.5	9.6	8.6	8.0	7.6	8.8	8.7	7.7			6.8	6.8				
28.0	11.3	10.5	9.7	9.2	8.8	9.8	9.0	8.1	7.5	7.1	8.8	8.1	7.2			6.8	6.8				
30.0	10.3	9.7	9.0	8.5	8.2	9.0	8.2	7.5	6.9	6.6	8.4	7.7	6.8	6.3		6.8	6.8				
32.0	9.4	8.9	8.3	7.9	7.6	8.2	7.6	6.9	6.4	6.1	7.7	7.0	6.3	5.8	5.5	6.8	6.5	5.7			
34.0	8.7	8.2	7.6	7.3	7.1	7.5	7.0	6.4	6.0	5.7	7.1	6.5	5.8	5.4	5.1	6.5	5.9	5.3			
36.0	7.9	7.5	7.0	6.8	6.6	6.9	6.4	5.9	5.5	5.3	6.5	6.0	5.4	5.0	4.7	6.0	5.5	4.9	4.5		
38.0	7.3	6.9	6.5	6.3		6.3	5.9	5.4	5.1	4.9	5.9	5.5	5.0	4.6	4.4	5.5	5.0	4.5	4.2		
40.0	6.1	6.3	6.0	5.8		5.7	5.4	5.0	4.7	4.6	5.4	5.0	4.6	4.3	4.1	5.0	4.6	4.2	3.9	3.7	
42.0	4.5	5.1	5.5	5.3		5.2	4.9	4.6	4.3	4.2	5.0	4.6	4.2	4.0	3.8	4.6	4.2	3.8	3.6	3.4	
44.0	3.1	3.6	4.2	4.4		4.8	4.5	4.2	4.0		4.5	4.2	3.9	3.7	3.5	4.2	3.9	3.5	3.3	3.1	
46.0			2.8	2.9		4.1	4.1	3.8	3.7		4.1	3.9	3.6	3.4	3.2	3.8	3.5	3.2	3.0	2.9	
48.0						2.9	3.7	3.5	3.4		3.7	3.5	3.3	3.1	3.0	3.5	3.2	3.0	2.8	2.7	
50.0							2.5	3.2	3.1		3.4	3.2	3.0	2.8	2.7	3.1	2.9	2.7	2.5	2.4	
54.0												2.6	2.4	2.3		2.5	2.4	2.2	2.1	2.0	
58.0																	1.9	1.8	1.7		
θ(°)	51~ 84.5	53~ 84.5	52~ 84.5	52~ 84.5	64~ 84.5	53~ 84.5	53~ 84.5	56~ 84.5	57~ 84.5	66~ 84.5	56~ 84.5	56~ 84.5	59~ 84.5	62~ 84.5	67~ 84.5	58~ 84.5	58~ 84.5	62~ 84.5	66~ 84.5	71~ 84.5	
標準フック						35t					12.2t										
フック重量						950kg					440kg										
標準巻掛本数						2					1										

PS+フルオートラフィングジブ

カウンタウエイト 98t、アウトリガ張出幅 8.0m
PS+60.0mブーム+2.3m+フルオートラフィングジブ

単位:t

ジブ長さ(m) 作業半径 (m)	10.3m オフセット					17.2m オフセット					24.1m オフセット					31.0m オフセット						
	5°	15°	30°	45°	60°	5°	15°	30°	45°	60°	5°	15°	30°	45°	60°	5°	15°	30°	45°	60°		
14.0	11.5																					
16.0	11.5	11.5				8.7																
18.0	11.5	11.5	11.5	11.5		8.7	8.7							6.8								
20.0	11.5	11.5	11.5	11.0	10.5	8.7	8.7							6.8					5.3			
22.0	11.5	11.5	11.0	10.4	9.9	8.7	8.7	8.7						6.8	6.8				5.3			
24.0	11.5	11.3	10.2	9.5	9.2	8.7	8.7	8.4						6.8	6.8				5.3			
26.0	11.2	10.4	9.3	8.7	8.4	8.7	8.7	7.6	7.0	6.6	6.8	6.8						5.3	5.3			
28.0	10.3	9.4	8.5	7.9	7.7	8.7	8.0	7.0	6.4	6.1	6.8	6.8	5.9					5.3	5.3			
30.0	9.2	8.5	7.7	7.3	7.1	8.1	7.2	6.4	5.9	5.6	6.8	6.2	5.4					5.3	5.3			
32.0	8.3	7.6	7.0	6.6	6.5	7.3	6.6	5.8	5.4	5.2	6.3	5.6	4.9	4.5				5.3	5.0			
34.0	7.4	6.9	6.3	6.0	5.9	6.6	5.9	5.3	4.9	4.8	5.7	5.1	4.5	4.1	3.9			5.1	4.5	4.0		
36.0	6.6	6.2	5.7	5.5	5.4	5.9	5.4	4.8	4.5	4.4	5.1	4.6	4.1	3.8	3.6			4.6	4.1	3.6		
38.0	5.9	5.5	5.1	4.9	4.9	5.3	4.8	4.4	4.1	4.0	4.6	4.2	3.7	3.5	3.3			4.2	3.7	3.3	3.0	
40.0	5.3	5.0	4.6	4.5		4.7	4.3	4.0	3.7	3.7	4.1	3.8	3.4	3.1	3.0			3.7	3.4	3.0	2.8	
42.0	4.4	4.4	4.1	4.0		4.2	3.9	3.6	3.4	3.3	3.7	3.4	3.0	2.8	2.8			3.3	3.0	2.7	2.5	2.4
44.0		3.5	3.7	3.6		3.7	3.5	3.2	3.0	3.0	3.3	3.0	2.7	2.6	2.5	3.0		2.7	2.4	2.3	2.2	
46.0						3.3	3.1	2.8	2.7		2.9	2.7	2.4	2.3	2.3	2.6		2.4	2.2	2.0	2.0	
48.0							2.7	2.5	2.4		2.6	2.4	2.2	2.1	2.0	2.3		2.1	1.9	1.8	1.8	
50.0								2.2	2.1		2.2	2.1	1.9	1.8	1.8	2.0		1.9	1.7	1.6	1.6	
θ(°)	57~ 84.5	56~ 84.5	58~ 84.5	58~ 84.5	65~ 84.5	59~ 84.5	59~ 84.5	59~ 84.5	60~ 84.5	67~ 84.5	59~ 84.5	62~ 84.5	65~ 84.5	68~ 84.5	69~ 84.5	63~ 84.5	66~ 84.5	71~ 84.5	75~ 84.5	77~ 84.5		
標準フック											12.2t											
フック重量											440kg											
標準巻掛本数											1											

カウンタウエイト 78t、アウトリガ張出幅 8.5m
PS+40.4mブーム+2.3m+フルオートラフィングジブ

単位:t

ジブ長さ(m) 作業半径 (m)	10.3m オフセット					17.2m オフセット					24.1m オフセット					31.0m オフセット						
	5°	15°	30°	45°	60°	5°	15°	30°	45°	60°	5°	15°	30°	45°	60°	5°	15°	30°	45°	60°		
9.0	37.6																					
10.0	37.6					16.7																
11.0	37.6	37.6				16.7																
12.0	37.6	37.6				16.7																
14.0	37.6	37.6	30.3	25.6		16.7	16.7				16.4											
16.0	36.3	35.0	29.0	24.8	22.8	16.7	16.7				16.0							10.9				
18.0	31.7	30.8	27.8	24.2	22.4	16.7	16.7	16.7			15.6	14.0						10.9				
20.0	27.9	27.2	26.6	23.5	22.1	16.7	16.7	16.7	14.9		15.2	13.6						10.7				
22.0	24.6	24.2	23.7	23.0	21.9	16.7	16.7	16.7	14.5	13.1	14.7	13.1	11.6					10.5	9.7			
24.0	21.8	21.5	21.2	21.1	21.2	16.7	16.7	16.3	14.1	12.9	14.2	12.7	11.3					10.3	9.3			
26.0	18.4	19.2	19.0	18.9	19.0	16.7	16.7	15.7	13.7	12.7	13.7	12.3	11.0	9.8				10.0	8.9			
28.0	14.9	15.9	17.0	17.0	17.1	16.6	16.4	15.2	13.4	12.5	13.2	12.0	10.6	9.6				9.8	8.5	7.2		
30.0	11.9	12.8	13.9	14.5		15.0	14.9	14.7	13.1	12.4	12.8	11.7	10.3	9.3	8.5			9.5	8.2	7.0		
32.0	9.4	10.2	11.1	11.6		12.6	13.4	13.5	12.8	12.3	12.4	11.4	10.1	9.1	8.4			9.1	7.9	6.7		
34.0	7.1	7.8	8.6	9.0		10.4	11.6	12.2	12.3	12.2	11.8	11.1	9.8	8.9	8.3			8.7	7.6	6.5	5.7	
36.0	5.2	5.8	6.4	6.7		8.4	9.5	10.9	11.2	11.3	10.7	10.7	9.5	8.8	8.2			8.4	7.4	6.3	5.6	5.3
38.0	3.4	4.0	4.5	4.6		6.6	7.6	8.9	9.7		8.9	9.8	9.3	8.6	8.1			8.0	7.1	6.1	5.4	5.2
40.0						5.0	5.9	7.0	7.7		7.3	8.7	9.1	8.4	8.1			7.7	6.9	5.9	5.3	5.1
42.0			2.7			3.6	4.4	5.4	5.8		5.9	7.1	8.3	8.3	8.0			7.5	6.7	5.8	5.2	5.1
44.0						2.3	3.0	3.8	4.1		4.6	5.7	7.2	7.8				6.7	6.5	5.6	5.2	5.0
46.0							1.8	2.4			3.4	4.4	5.7	6.6				5.5	6.3	5.5	5.1	5.0
48.0											2.3	3.3	4.4	5.1				4.4	5.7	5.3	5.1	5.0
50.0												2.2	3.2	3.7				3.4	4.6	5.2	5.0	4.9
54.0																		1.7	2.6	3.9	4.7	
58.0																				1.9	2.4	
θ(°)	45~ 84.5	46~ 84.5	44~ 84.5	48~ 84.5	64~ 84.5	45~ 84.5	44~ 84.5	47~ 84.5	52~ 84.5	65~ 84.5	46~ 84.5	48~ 84.5	51~ 84.5	53~ 84.5	66~ 84.5	46~ 84.5	50~ 84.5	50~ 84.5	53~ 84.5	66~ 84.5		
標準フック											35t											
フック重量											950kg											
標準巻掛本数											2											

カウンタウエイト 78t、アウトリガ張出幅 8.5m
PS+45.4mブーム+2.3m+フルオートラフィングジブ

単位:t

ジブ長さ(m) 作業半径 (m)	10.3m オフセット					17.2m オフセット					24.1m オフセット					31.0m オフセット				
	5°	15°	30°	45°	60°	5°	15°	30°	45°	60°	5°	15°	30°	45°	60°	5°	15°	30°	45°	60°
10.0	28.6																			
11.0	28.6																			
12.0	28.6	28.6				16.7														
14.0	28.6	28.6	28.6			16.7					15.5									
16.0	28.6	28.6	28.6	25.2	23.0	16.7	16.7				15.3									
18.0	28.6	28.6	28.1	24.6	22.7	16.7	16.7				14.9	13.9				10.5				
20.0	26.2	25.5	24.9	24.0	22.4	16.7	16.7	16.7			14.7	13.5				10.3				
22.0	23.0	22.6	22.1	22.0	22.0	16.7	16.7	16.7	14.6		14.4	13.1				10.1	9.5			
24.0	20.3	20.0	19.7	19.6	19.7	16.7	16.7	16.6	14.2	12.9	14.1	12.7	11.3			9.9	9.2			
26.0	18.0	17.8	17.6	17.5	17.6	16.7	16.7	16.1	13.9	12.7	13.7	12.3	11.0			9.7	8.9			
28.0	15.1	15.8	15.7	15.7	15.8	15.4	15.2	15.1	13.6	12.6	13.3	12.0	10.6	9.6		9.5	8.6			
30.0	12.2	13.1	14.0	14.0	14.1	13.7	13.7	13.7	13.3	12.5	12.9	11.7	10.4	9.4	8.6	9.3	8.2	7.0		
32.0	9.6	10.5	11.5	12.1		12.3	12.3	12.4	12.5	12.4	11.9	11.4	10.1	9.2	8.4	9.2	8.0	6.8		
34.0	7.4	8.1	9.0	9.5		10.3	11.0	11.2	11.3	11.5	10.7	10.8	9.8	9.0	8.3	8.8	7.7	6.6	5.7	
36.0	5.4	6.1	6.9	7.2		8.3	9.5	10.0	10.2	10.3	9.7	9.8	9.6	8.8	8.2	8.5	7.4	6.4	5.6	
38.0	3.7	4.3	4.9	5.2		6.5	7.6	9.0	9.2	9.3	8.7	8.9	9.1	8.7	8.1	8.2	7.2	6.2	5.4	5.2
40.0	2.1	2.7	3.2	3.4		4.9	5.9	7.2	7.9		7.1	8.0	8.3	8.5	8.1	7.9	7.0	6.0	5.3	5.2
42.0						3.5	4.4	5.5	6.2		5.7	7.0	7.5	7.7	8.0	7.2	6.8	5.8	5.2	5.1
44.0						2.3	3.1	4.0	4.5		4.4	5.6	6.8	7.0	7.2	6.4	6.6	5.7	5.1	5.0
46.0								2.7	3.0		3.2	4.3	5.7	6.3		5.2	6.1	5.5	5.1	5.0
48.0												3.2	4.4	5.3		4.1	5.5	5.4	5.1	4.9
50.0													3.2	3.9		3.1	4.4	5.3	5.0	4.9
54.0																	2.5	3.8	4.5	
58.0																			2.6	
θ(°)	48~ 84.5	49~ 84.5	50~ 84.5	51~ 84.5	66~ 84.5	50~ 84.5	52~ 84.5	52~ 84.5	53~ 84.5	65~ 84.5	53~ 84.5	55~ 84.5	57~ 84.5	60~ 84.5	68~ 84.5	54~ 84.5	55~ 84.5	60~ 84.5	58~ 84.5	70~ 84.5
標準フック	35t					35t					12.2t									
フック重量	950kg					950kg					440kg									
標準巻掛本数	3					2					1									

PS+FLJ

カウンタウエイト 78t、アウトリガ張出幅 8.5m
PS+50.5mブーム+2.3m+フルオートラフィングジブ

単位:t

ジブ長さ(m) 作業半径 (m)	10.3m オフセット					17.2m オフセット					24.1m オフセット					31.0m オフセット				
	5°	15°	30°	45°	60°	5°	15°	30°	45°	60°	5°	15°	30°	45°	60°	5°	15°	30°	45°	60°
11.0	21.0																			
12.0	21.0																			
14.0	21.0	20.4				15.9														
16.0	21.0	19.0	16.7	15.2		15.9	15.6				12.2									
18.0	19.7	17.8	15.7	14.4	13.6	15.9	14.5				12.2					9.0				
20.0	18.4	16.6	14.8	13.7	13.0	15.5	13.6	11.7			12.2	11.5				9.0				
22.0	17.2	15.7	14.0	13.0	12.4	14.5	12.8	11.1	10.0		12.2	10.9				9.0				
24.0	16.1	14.8	13.3	12.4	11.9	13.5	12.1	10.6	9.6	9.0	11.7	10.2				9.0	8.9			
26.0	15.1	13.9	12.7	11.9	11.5	12.7	11.4	10.0	9.2	8.6	10.9	9.7	8.4			9.0	8.7			
28.0	14.3	13.2	12.1	11.4	11.1	12.0	10.8	9.6	8.8	8.3	10.3	9.1	8.0			9.0	8.3			
30.0	12.4	12.6	11.6	11.0	10.7	11.3	10.2	9.1	8.4	8.0	9.7	8.7	7.6	6.9		8.8	7.8	6.8		
32.0	9.8	10.7	11.1	10.5	10.3	10.7	9.7	8.7	8.1	7.8	9.2	8.2	7.2	6.6	6.2	8.4	7.4	6.5		
34.0	7.6	8.4	9.3	9.9	10.0	10.1	9.3	8.4	7.8	7.5	8.7	7.8	6.9	6.4	5.9	7.9	7.1	6.2		
36.0	5.7	6.4	7.2	7.7		8.4	8.8	8.0	7.5	7.2	8.2	7.4	6.6	6.0	5.7	7.5	6.7	5.9	5.4	
38.0	3.9	4.6	5.3	5.7		6.7	7.8	7.7	7.1	6.9	7.8	7.1	6.3	5.7	5.4	7.1	6.4	5.6	5.1	4.7
40.0		3.0	3.6	3.9		5.1	6.2	7.3	6.8	6.6	7.1	6.7	5.9	5.4	5.1	6.7	6.1	5.3	4.8	4.4
42.0						3.7	4.7	5.8	6.5		5.7	6.3	5.6	5.2	4.9	6.4	5.7	5.0	4.5	4.2
44.0							3.3	4.4	5.0		4.4	5.7	5.3	4.9	4.7	6.0	5.4	4.7	4.3	4.0
46.0								3.0	3.5		3.2	4.4	5.0	4.7	4.5	5.2	5.1	4.5	4.1	3.8
48.0												3.3	4.6	4.4	4.3	4.1	4.7	4.2	3.8	3.6
50.0													3.4	4.2		3.1	4.4	4.0	3.6	3.5
54.0																		3.5	3.3	3.1
θ(°)	54~ 84.5	54~ 84.5	55~ 84.5	56~ 84.5	63~ 84.5	55~ 84.5	56~ 84.5	56~ 84.5	58~ 84.5	66~ 84.5	56~ 84.5	58~ 84.5	60~ 84.5	62~ 84.5	65~ 84.5	57~ 84.5	62~ 84.5	63~ 84.5	66~ 84.5	68~ 84.5
標準フック	35t					12.2t														
フック重量	950kg					440kg														
標準巻掛本数	2					1														

PS+フルオートラフィングジブ

カウンタウエイト 78t、アウトリガ張出幅 8.5m
PS+55.6mブーム+2.3m+フルオートラフィングジブ

単位:t

ジブ長さ(m) 作業半径 (m)	10.3m オフセット					17.2m オフセット					24.1m オフセット					31.0m オフセット				
	5°	15°	30°	45°	60°	5°	15°	30°	45°	60°	5°	15°	30°	45°	60°	5°	15°	30°	45°	60°
12.0	15.0																			
14.0	15.0	15.0				11.7														
16.0	15.0	15.0	14.5			11.7														
18.0	15.0	15.0	13.5	12.6	11.9	11.7	11.7				8.8									
20.0	15.0	13.9	12.6	11.8	11.3	11.7	11.7				8.8					6.8				
22.0	14.0	13.0	11.9	11.1	10.7	11.7	10.9	9.7			8.8	8.8				6.8				
24.0	13.0	12.1	11.1	10.5	10.1	11.2	10.2	9.1	8.4		8.8	8.8				6.8				
26.0	12.1	11.3	10.5	9.9	9.5	10.5	9.6	8.6	8.0	7.6	8.8	8.7	7.7			6.8	6.8			
28.0	11.3	10.5	9.7	9.2	8.8	9.8	9.0	8.1	7.5	7.1	8.8	8.1	7.2			6.8	6.8			
30.0	10.3	9.7	9.0	8.5	8.2	9.0	8.2	7.5	6.9	6.6	8.4	7.7	6.8	6.3		6.8	6.8			
32.0	9.4	8.9	8.3	7.9	7.6	8.2	7.6	6.9	6.4	6.1	7.7	7.0	6.3	5.8	5.5	6.8	6.5	5.7		
34.0	8.2	8.2	7.6	7.3	7.1	7.5	7.0	6.4	6.0	5.7	7.1	6.5	5.8	5.4	5.1	6.5	5.9	5.3		
36.0	6.3	7.0	7.0	6.8	6.6	6.9	6.4	5.9	5.5	5.3	6.5	6.0	5.4	5.0	4.7	6.0	5.5	4.9	4.5	
38.0	4.5	5.2	6.0	6.3		6.3	5.9	5.4	5.1	4.9	5.9	5.5	5.0	4.6	4.4	5.5	5.0	4.5	4.2	
40.0			4.3	4.7		5.3	5.4	5.0	4.7	4.6	5.4	5.0	4.6	4.3	4.1	5.0	4.6	4.2	3.9	3.7
42.0						3.8	4.8	4.6	4.3	4.2	5.0	4.6	4.2	4.0	3.8	4.6	4.2	3.8	3.6	3.4
44.0								4.2	4.0		4.5	4.2	3.9	3.7	3.5	4.2	3.9	3.5	3.3	3.1
46.0									3.7			3.9	3.6	3.4	3.2	3.8	3.5	3.2	3.0	2.9
48.0												3.5	3.3	3.1	3.0	3.5	3.2	3.0	2.8	2.7
50.0														3.0	2.8	2.7		2.9	2.7	2.4
54.0																		2.2	2.1	2.0
θ (°)	58~ 84.5	59~ 84.5	59~ 84.5	60~ 84.5	64~ 84.5	58~ 84.5	61~ 84.5	62~ 84.5	61~ 84.5	66~ 84.5	62~ 84.5	61~ 84.5	63~ 84.5	66~ 84.5	67~ 84.5	63~ 84.5	64~ 84.5	66~ 84.5	69~ 84.5	71~ 84.5
標準フック	35t										12.2t									
フック重量	950kg										440kg									
標準巻掛本数	2										1									

カウンタウエイト 78t、アウトリガ張出幅 8.5m
PS+60.0mブーム+2.3m+フルオートラフィングジブ

単位:t

ジブ長さ(m) 作業半径 (m)	10.3m オフセット					17.2m オフセット					24.1m オフセット					31.0m オフセット				
	5°	15°	30°	45°	60°	5°	15°	30°	45°	60°	5°	15°	30°	45°	60°	5°	15°	30°	45°	60°
14.0	11.5																			
16.0	11.5	11.5				8.7														
18.0	11.5	11.5	11.5	11.5		8.7	8.7				6.8									
20.0	11.5	11.5	11.5	11.0	10.5	8.7	8.7				6.8					5.3				
22.0	11.5	11.5	11.0	10.4	9.9	8.7	8.7	8.7			6.8	6.8				5.3				
24.0	11.5	11.3	10.2	9.5	9.2	8.7	8.7	8.4			6.8	6.8				5.3				
26.0	11.2	10.4	9.3	8.7	8.4	8.7	8.7	7.6	7.0	6.6	6.8	6.8				5.3	5.3			
28.0	10.3	9.4	8.5	7.9	7.7	8.7	8.0	7.0	6.4	6.1	6.8	6.8	5.9			5.3	5.3			
30.0	9.2	8.5	7.7	7.3	7.1	8.1	7.2	6.4	5.9	5.6	6.8	6.2	5.4			5.3	5.3			
32.0	8.3	7.6	7.0	6.6	6.5	7.3	6.6	5.8	5.4	5.2	6.3	5.6	4.9	4.5		5.3	5.0			
34.0	7.4	6.9	6.3	6.0	5.9	6.6	5.9	5.3	4.9	4.8	5.7	5.1	4.5	4.1	3.9	5.1	4.5	4.0		
36.0	6.1	6.2	5.7	5.5	5.4	5.9	5.4	4.8	4.5	4.4	5.1	4.6	4.1	3.8	3.6	4.6	4.1	3.6		
38.0		5.1	5.1	4.9	4.9	5.3	4.8	4.4	4.1	4.0	4.6	4.2	3.7	3.5	3.3	4.2	3.7	3.3	3.0	
40.0				4.5		4.7	4.3	4.0	3.7	3.7	4.1	3.8	3.4	3.1	3.0	3.7	3.4	3.0	2.8	
42.0							3.9	3.6	3.4	3.3	3.7	3.4	3.0	2.8	2.8	3.3	3.0	2.7	2.5	2.4
44.0								3.2	3.0	3.0		3.0	2.7	2.6	2.5	3.0	2.7	2.4	2.3	2.2
46.0												2.7	2.4	2.3	2.3	2.6	2.4	2.2	2.0	2.0
48.0													2.2	2.1	2.0		2.1	1.9	1.8	1.8
50.0														1.8	1.8			1.7	1.6	1.6
θ (°)	63~ 84.5	62~ 84.5	64~ 84.5	63~ 84.5	65~ 84.5	64~ 84.5	64~ 84.5	65~ 84.5	66~ 84.5	67~ 84.5	66~ 84.5	65~ 84.5	67~ 84.5	68~ 84.5	69~ 84.5	66~ 84.5	68~ 84.5	71~ 84.5	75~ 84.5	77~ 84.5
標準フック											12.2t									
フック重量											440kg									
標準巻掛本数											1									

カウンタウエイト 78t、アウトリガ張出幅 8.0m
PS+40.4mブーム+2.3m+フルオートラフィングジブ

単位:t

ジブ長さ(m) 作業半径 (m)	10.3m オフセット					17.2m オフセット					24.1m オフセット					31.0m オフセット				
	5°	15°	30°	45°	60°	5°	15°	30°	45°	60°	5°	15°	30°	45°	60°	5°	15°	30°	45°	60°
9.0	37.6																			
10.0	37.6					16.7														
11.0	37.6	37.6				16.7														
12.0	37.6	37.6				16.7														
14.0	37.6	37.6	30.3	25.6		16.7	16.7				16.4									
16.0	36.3	35.0	29.0	24.8	22.8	16.7	16.7				16.0					10.9				
18.0	31.7	30.8	27.8	24.2	22.4	16.7	16.7	16.7			15.6	14.0				10.9				
20.0	27.9	27.2	26.6	23.5	22.1	16.7	16.7	16.7	14.9		15.2	13.6				10.7				
22.0	24.6	24.2	23.7	23.0	21.9	16.7	16.7	16.7	14.5	13.1	14.7	13.1	11.6			10.5	9.7			
24.0	21.0	21.5	21.2	21.1	21.2	16.7	16.7	16.3	14.1	12.9	14.2	12.7	11.3			10.3	9.3			
26.0	17.1	18.3	19.0	18.9	19.0	16.7	16.7	15.7	13.7	12.7	13.7	12.3	11.0	9.8		10.0	8.9			
28.0	13.7	14.7	16.0	16.8	16.9	16.6	16.4	15.2	13.4	12.5	13.2	12.0	10.6	9.6		9.8	8.5	7.2		
30.0	10.7	11.7	12.7	13.4		14.1	14.9	14.7	13.1	12.4	12.8	11.7	10.3	9.3	8.5	9.5	8.2	7.0		
32.0	8.2	9.0	10.0	10.5		11.6	13.0	13.5	12.8	12.3	12.4	11.4	10.1	9.1	8.4	9.1	7.9	6.7		
34.0	6.1	6.8	7.6	7.9		9.3	10.6	12.2	12.3	12.2	11.7	11.1	9.8	8.9	8.3	8.7	7.6	6.5	5.7	
36.0	4.1	4.8	5.4	5.7		7.4	8.5	10.0	10.9	11.2	9.7	10.7	9.5	8.8	8.2	8.4	7.4	6.3	5.6	5.3
38.0	2.5	3.0	3.5	3.6		5.6	6.7	8.0	8.8		8.0	9.5	9.3	8.6	8.1	8.0	7.1	6.1	5.4	5.2
40.0						4.1	5.0	6.2	6.8		6.4	7.8	9.1	8.4	8.1	7.7	6.9	5.9	5.3	5.1
42.0						2.7	3.5	4.5	5.0		5.0	6.3	7.9	8.3	8.0	7.2	6.7	5.8	5.2	5.1
44.0							2.2	3.0	3.3		3.8	4.9	6.4	7.4		5.9	6.5	5.6	5.2	5.0
46.0											2.6	3.7	5.0	5.8		4.7	6.1	5.5	5.1	5.0
48.0												2.5	3.7	4.3		3.7	4.9	5.3	5.1	5.0
50.0													2.5	2.9		2.7	3.9	5.2	5.0	4.9
54.0																		3.2	4.0	
θ(°)	45~ 84.5	46~ 84.5	48~ 84.5	48~ 84.5	64~ 84.5	48~ 84.5	47~ 84.5	50~ 84.5	52~ 84.5	65~ 84.5	49~ 84.5	50~ 84.5	51~ 84.5	53~ 84.5	66~ 84.5	50~ 84.5	55~ 84.5	56~ 84.5	59~ 84.5	66~ 84.5
標準フック											35t					12.2t				
フック重量	1550kg										950kg					440kg				
標準巻掛本数	4										2					1				

PS+FLJ

カウンタウエイト 78t、アウトリガ張出幅 8.0m
PS+45.4mブーム+2.3m+フルオートラフィングジブ

単位:t

ジブ長さ(m) 作業半径 (m)	10.3m オフセット					17.2m オフセット					24.1m オフセット					31.0m オフセット				
	5°	15°	30°	45°	60°	5°	15°	30°	45°	60°	5°	15°	30°	45°	60°	5°	15°	30°	45°	60°
10.0	28.6																			
11.0	28.6																			
12.0	28.6	28.6				16.7														
14.0	28.6	28.6	28.6			16.7					15.5									
16.0	28.6	28.6	28.6	25.2	23.0	16.7	16.7				15.3									
18.0	28.6	28.6	28.1	24.6	22.7	16.7	16.7				14.9	13.9				10.5				
20.0	26.2	25.5	24.9	24.0	22.4	16.7	16.7	16.7			14.7	13.5				10.3				
22.0	23.0	22.6	22.1	22.0	22.0	16.7	16.7	16.7	14.6		14.4	13.1				10.1	9.5			
24.0	20.3	20.0	19.7	19.6	19.7	16.7	16.7	16.6	14.2	12.9	14.1	12.7	11.3			9.9	9.2			
26.0	17.3	17.8	17.6	17.5	17.6	16.7	16.7	16.1	13.9	12.7	13.7	12.3	11.0			9.7	8.9			
28.0	13.9	15.0	15.7	15.7	15.8	15.4	15.2	15.1	13.6	12.6	13.3	12.0	10.6	9.6		9.5	8.6			
30.0	11.0	12.0	13.1	13.9	14.1	13.7	13.7	13.7	13.3	12.5	12.9	11.7	10.4	9.4	8.6	9.3	8.2	7.0		
32.0	8.5	9.3	10.4	11.0		11.5	12.3	12.4	12.5	12.4	11.9	11.4	10.1	9.2	8.4	9.2	8.0	6.8		
34.0	6.3	7.1	8.0	8.5		9.2	10.6	11.2	11.3	11.5	10.7	10.8	9.8	9.0	8.3	8.8	7.7	6.6	5.7	
36.0	4.4	5.1	5.9	6.2		7.3	8.5	10.0	10.2	10.3	9.5	9.8	9.6	8.8	8.2	8.5	7.4	6.4	5.6	
38.0	2.7	3.3	4.0	4.2		5.6	6.7	8.1	9.0	9.3	7.8	8.9	9.1	8.7	8.1	8.2	7.2	6.2	5.4	5.2
40.0						4.0	5.0	6.3	7.1		6.2	7.6	8.3	8.5	8.1	7.9	7.0	6.0	5.3	5.2
42.0							3.6	4.7	5.3		4.8	6.1	7.5	7.7	8.0	6.9	6.8	5.8	5.2	5.1
44.0								3.2	3.7		3.6	4.8	6.4	7.0	7.2	5.6	6.6	5.7	5.1	5.0
46.0												3.5	5.0	5.9		4.5	5.9	5.5	5.1	5.0
48.0													3.7	4.5		3.4	4.7	5.4	5.1	4.9
50.0														3.2			3.7	5.3	5.0	4.9
54.0																		3.2	4.2	
θ(°)	50~ 84.5	52~ 84.5	54~ 84.5	54~ 84.5	66~ 84.5	55~ 84.5	55~ 84.5	55~ 84.5	56~ 84.5	65~ 84.5	55~ 84.5	57~ 84.5	60~ 84.5	60~ 84.5	68~ 84.5	56~ 84.5	59~ 84.5	60~ 84.5	63~ 84.5	70~ 84.5
標準フック											35t					12.2t				
フック重量	950kg										950kg					440kg				
標準巻掛本数	3										2					1				

PS+フルオートラフィングジブ

カウンタウエイト 78t、アウトリガ張出幅 8.0m
PS+50.5mブーム+2.3m+フルオートラフィングジブ

単位:t

ジブ長さ(m) 作業半径 (m)	10.3m オフセット					17.2m オフセット					24.1m オフセット					31.0m オフセット				
	5°	15°	30°	45°	60°	5°	15°	30°	45°	60°	5°	15°	30°	45°	60°	5°	15°	30°	45°	60°
11.0	21.0																			
12.0	21.0																			
14.0	21.0	20.4				15.9														
16.0	21.0	19.0	16.7	15.2		15.9	15.6				12.2									
18.0	19.7	17.8	15.7	14.4	13.6	15.9	14.5				12.2					9.0				
20.0	18.4	16.6	14.8	13.7	13.0	15.5	13.6	11.7			12.2	11.5				9.0				
22.0	17.2	15.7	14.0	13.0	12.4	14.5	12.8	11.1	10.0		12.2	10.9				9.0				
24.0	16.1	14.8	13.3	12.4	11.9	13.5	12.1	10.6	9.6	9.0	11.7	10.2				9.0	8.9			
26.0	15.1	13.9	12.7	11.9	11.5	12.7	11.4	10.0	9.2	8.6	10.9	9.7	8.4			9.0	8.7			
28.0	14.1	13.2	12.1	11.4	11.1	12.0	10.8	9.6	8.8	8.3	10.3	9.1	8.0			9.0	8.3			
30.0	11.2	12.2	11.6	11.0	10.7	11.3	10.2	9.1	8.4	8.0	9.7	8.7	7.6	6.9		8.8	7.8	6.8		
32.0	8.7	9.6	10.7	10.5	10.3	10.7	9.7	8.7	8.1	7.8	9.2	8.2	7.2	6.6	6.2	8.4	7.4	6.5		
34.0	6.5	7.3	8.3	8.9	9.0	9.4	9.3	8.4	7.8	7.5	8.7	7.8	6.9	6.4	5.9	7.9	7.1	6.2		
36.0	4.6	5.4	6.2	6.7		7.5	8.7	8.0	7.5	7.2	8.2	7.4	6.6	6.0	5.7	7.5	6.7	5.9	5.4	
38.0		3.6	4.4	4.7		5.7	6.9	7.7	7.1	6.9	7.8	7.1	6.3	5.7	5.4	7.1	6.4	5.6	5.1	4.7
40.0						4.2	5.3	6.6	6.8	6.6	6.2	6.7	5.9	5.4	5.1	6.7	6.1	5.3	4.8	4.4
42.0							3.8	5.0	5.7		4.8	6.2	5.6	5.2	4.9	6.4	5.7	5.0	4.5	4.2
44.0								3.5	4.2		3.6	4.9	5.3	4.9	4.7	5.5	5.4	4.7	4.3	4.0
46.0												3.6	5.0	4.7	4.5	4.4	5.1	4.5	4.1	3.8
48.0													3.9	4.4	4.3		4.7	4.2	3.8	3.6
50.0														3.6			3.7	4.0	3.6	3.5
54.0																			3.3	3.1
θ(°)	57~84.5	56~84.5	58~84.5	58~84.5	63~84.5	57~84.5	58~84.5	58~84.5	60~84.5	66~84.5	58~84.5	60~84.5	62~84.5	62~84.5	65~84.5	60~84.5	62~84.5	67~84.5	66~84.5	68~84.5
標準フック	35t										12.2t									
フック重量	950kg										440kg									
標準巻掛本数	2										1									

カウンタウエイト 78t、アウトリガ張出幅 8.0m
PS+55.6mブーム+2.3m+フルオートラフィングジブ

単位:t

ジブ長さ(m) 作業半径 (m)	10.3m オフセット					17.2m オフセット					24.1m オフセット					31.0m オフセット					
	5°	15°	30°	45°	60°	5°	15°	30°	45°	60°	5°	15°	30°	45°	60°	5°	15°	30°	45°	60°	
12.0	15.0																				
14.0	15.0	15.0				11.7															
16.0	15.0	15.0	14.5			11.7															
18.0	15.0	15.0	13.5	12.6	11.9	11.7	11.7				8.8										
20.0	15.0	13.9	12.6	11.8	11.3	11.7	11.7				8.8					6.8					
22.0	14.0	13.0	11.9	11.1	10.7	11.7	10.9	9.7			8.8	8.8				6.8					
24.0	13.0	12.1	11.1	10.5	10.1	11.2	10.2	9.1	8.4		8.8	8.8				6.8					
26.0	12.1	11.3	10.5	9.9	9.5	10.5	9.6	8.6	8.0	7.6	8.8	8.7	7.7			6.8	6.8				
28.0	11.3	10.5	9.7	9.2	8.8	9.8	9.0	8.1	7.5	7.1	8.8	8.1	7.2			6.8	6.8				
30.0	10.3	9.7	9.0	8.5	8.2	9.0	8.2	7.5	6.9	6.6	8.4	7.7	6.8	6.3		6.8	6.8				
32.0	9.3	8.9	8.3	7.9	7.6	8.2	7.6	6.9	6.4	6.1	7.7	7.0	6.3	5.8	5.5	6.8	6.5	5.7			
34.0	7.2	8.0	7.6	7.3	7.1	7.5	7.0	6.4	6.0	5.7	7.1	6.5	5.8	5.4	5.1	6.5	5.9	5.3			
36.0	5.3	6.0	6.9	6.8	6.6	6.9	6.4	5.9	5.5	5.3	6.5	6.0	5.4	5.0	4.7	6.0	5.5	4.9	4.5		
38.0			5.0	5.5		5.9	5.9	5.4	5.1	4.9	5.9	5.5	5.0	4.6	4.4	5.5	5.0	4.5	4.2		
40.0						4.3	5.4	5.0	4.7	4.6	5.4	5.0	4.6	4.3	4.1	5.0	4.6	4.2	3.9	3.7	
42.0								4.6	4.3	4.2	5.0	4.6	4.2	4.0	3.8	4.6	4.2	3.8	3.6	3.4	
44.0									4.0				4.2	3.9	3.7	4.2	3.9	3.5	3.3	3.1	
46.0														3.6	3.4	3.2	3.8	3.5	3.2	3.0	2.9
48.0														3.3	3.1	3.0		3.2	3.0	2.8	2.7
50.0															2.8	2.7			2.7	2.5	2.4
54.0																				2.1	2.0
θ(°)	60~84.5	61~84.5	61~84.5	62~84.5	64~84.5	60~84.5	63~84.5	64~84.5	64~84.5	66~84.5	63~84.5	65~84.5	65~84.5	66~84.5	67~84.5	64~84.5	66~84.5	69~84.5	69~84.5	71~84.5	
標準フック	35t										12.2t										
フック重量	950kg										440kg										
標準巻掛本数	2										1										

カウンタウエイト 78t、アウトリガ張出幅 8.0m
PS+60.0mブーム+2.3m+フルオートラフィングジブ

単位:t

ジブ長さ(m) 作業半径 (m)	10.3m オフセット					17.2m オフセット					24.1m オフセット					31.0m オフセット				
	5°	15°	30°	45°	60°	5°	15°	30°	45°	60°	5°	15°	30°	45°	60°	5°	15°	30°	45°	60°
14.0	11.5					8.7														
16.0	11.5	11.5				8.7	8.7													
18.0	11.5	11.5	11.5	11.5		8.7	8.7					6.8								
20.0	11.5	11.5	11.5	11.0	10.5	8.7	8.7					6.8						5.3		
22.0	11.5	11.5	11.0	10.4	9.9	8.7	8.7	8.7				6.8	6.8					5.3		
24.0	11.5	11.3	10.2	9.5	9.2	8.7	8.7	8.4				6.8	6.8					5.3		
26.0	11.2	10.4	9.3	8.7	8.4	8.7	8.7	7.6	7.0	6.6		6.8	6.8					5.3	5.3	
28.0	10.3	9.4	8.5	7.9	7.7	8.7	8.0	7.0	6.4	6.1		6.8	6.8	5.9				5.3	5.3	
30.0	9.2	8.5	7.7	7.3	7.1	8.1	7.2	6.4	5.9	5.6		6.8	6.2	5.4				5.3	5.3	
32.0	8.3	7.6	7.0	6.6	6.5	7.3	6.6	5.8	5.4	5.2		6.3	5.6	4.9	4.5			5.3	5.0	
34.0	7.0	6.9	6.3	6.0	5.9	6.6	5.9	5.3	4.9	4.8		5.7	5.1	4.5	4.1	3.9		5.1	4.5	4.0
36.0		5.8	5.7	5.5	5.4	5.9	5.4	4.8	4.5	4.4		5.1	4.6	4.1	3.8	3.6		4.6	4.1	3.6
38.0				4.9	4.9	5.3	4.8	4.4	4.1	4.0		4.6	4.2	3.7	3.5	3.3		4.2	3.7	3.3
40.0							4.3	4.0	3.7	3.7		4.1	3.8	3.4	3.1	3.0		3.7	3.4	3.0
42.0								3.6	3.4	3.3			3.4	3.0	2.8	2.8		3.3	3.0	2.7
44.0									3.0	3.0			3.0	2.7	2.6	2.5		3.0	2.7	2.4
46.0														2.4	2.3	2.3		2.4	2.2	2.0
48.0															2.1	2.0				1.9
50.0																				1.7
$\theta(^{\circ})$	65~ 84.5	64~ 84.5	66~ 84.5	65~ 84.5	65~ 84.5	66~ 84.5	66~ 84.5	66~ 84.5	66~ 84.5	67~ 84.5	67~ 84.5	66~ 84.5	69~ 84.5	70~ 84.5	71~ 84.5	68~ 84.5	69~ 84.5	68~ 84.5	71~ 84.5	75~ 84.5
標準フック	12.2t																			
フック重量	440kg																			
標準巻掛本数	1																			

PS+FLJ

カウンタウエイト 78t、アウトリガ張出幅 6.8m
PS+40.4mブーム+2.3m+フルオートラフィングジブ

単位:t

ジブ長さ(m) 作業半径 (m)	10.3m オフセット					17.2m オフセット					24.1m オフセット					31.0m オフセット				
	5°	15°	30°	45°	60°	5°	15°	30°	45°	60°	5°	15°	30°	45°	60°	5°	15°	30°	45°	60°
9.0	37.6																			
10.0	37.6					16.7														
11.0	37.6	37.6				16.7														
12.0	37.6	37.6				16.7														
14.0	37.6	37.6	30.3	25.6		16.7	16.7					16.4								
16.0	36.3	35.0	29.0	24.8	22.8	16.7	16.7					16.0						10.9		
18.0	31.2	30.8	27.8	24.2	22.4	16.7	16.7	16.7				15.6	14.0					10.9		
20.0	25.1	26.5	26.6	23.5	22.1	16.7	16.7	16.7	14.9			15.2	13.6					10.7		
22.0	20.4	21.5	23.1	23.0	21.9	16.7	16.7	16.7	14.5	13.1	14.7	13.1	11.6					10.5	9.7	
24.0	16.2	17.5	18.9	19.8	20.2	16.7	16.7	16.3	14.1	12.9	14.2	12.7	11.3					10.3	9.3	
26.0	12.6	13.7	15.2	16.1	16.5	16.0	16.7	15.7	13.7	12.7	13.7	12.3	11.0	9.8				10.0	8.9	
28.0	9.6	10.6	11.9	12.6	12.8	13.0	14.7	15.2	13.4	12.5	13.2	12.0	10.6	9.6				9.8	8.5	7.2
30.0	7.1	8.0	9.0	9.6		10.4	11.9	13.9	13.1	12.4	12.8	11.7	10.3	9.3	8.5			9.5	8.2	7.0
32.0	4.9	5.6	6.6	7.1		8.1	9.5	11.3	12.6	12.3	10.5	11.4	10.1	9.1	8.4			9.1	7.9	6.7
34.0		3.6	4.4	4.8		6.2	7.4	9.0	10.1	10.6	8.5	10.2	9.8	8.9	8.3			8.7	7.6	6.5
36.0						4.4	5.6	7.0	7.9	8.2	6.8	8.3	9.5	8.8	8.2			8.4	7.4	6.3
38.0						2.9	3.9	5.2	6.0		5.2	6.7	8.6	8.6	8.1			7.4	7.1	6.1
40.0								3.5	4.2		3.8	5.2	6.9	8.3	8.1			6.0	6.9	5.9
42.0												3.8	5.4	6.6	7.0			4.7	6.3	5.8
44.0													4.0	5.0				3.6	5.0	5.6
46.0														3.5				3.9	5.5	5.1
48.0																		2.8	4.5	5.1
50.0																			3.4	4.5
$\theta(^{\circ})$	54~ 84.5	53~ 84.5	55~ 84.5	55~ 84.5	64~ 84.5	54~ 84.5	56~ 84.5	57~ 84.5	58~ 84.5	65~ 84.5	56~ 84.5	58~ 84.5	59~ 84.5	60~ 84.5	66~ 84.5	57~ 84.5	57~ 84.5	60~ 84.5	64~ 84.5	66~ 84.5
標準フック	80t																			
フック重量	1550kg					35t					950kg					440kg				
標準巻掛本数	4					2					1					1				

PS+フルオートラフィングジブ

カウンタウエイト 78t、アウトリガ張出幅 6.8m
PS+45.4mブーム+2.3m+フルオートラフィングジブ

単位:t

ジブ長さ(m) 作業半径 (m)	10.3m オフセット					17.2m オフセット					24.1m オフセット					31.0m オフセット				
	5°	15°	30°	45°	60°	5°	15°	30°	45°	60°	5°	15°	30°	45°	60°	5°	15°	30°	45°	60°
10.0	28.6																			
11.0	28.6																			
12.0	28.6	28.6				16.7														
14.0	28.6	28.6	28.6			16.7					15.5									
16.0	28.6	28.6	28.6	25.2	23.0	16.7	16.7				15.3									
18.0	28.6	28.6	28.1	24.6	22.7	16.7	16.7				14.9	13.9				10.5				
20.0	25.3	25.5	24.9	24.0	22.4	16.7	16.7	16.7			14.7	13.5				10.3				
22.0	20.6	21.8	22.1	22.0	22.0	16.7	16.7	16.7	14.6		14.4	13.1				10.1	9.5			
24.0	16.4	17.8	19.2	19.6	19.7	16.7	16.7	16.6	14.2	12.9	14.1	12.7	11.3			9.9	9.2			
26.0	12.8	14.0	15.5	16.5	16.9	15.9	16.7	16.1	13.9	12.7	13.7	12.3	11.0			9.7	8.9			
28.0	9.9	10.9	12.2	13.1	13.4	12.9	14.6	15.1	13.6	12.6	13.3	12.0	10.6	9.6		9.5	8.6			
30.0	7.3	8.2	9.4	10.1	10.3	10.3	11.9	13.7	13.3	12.5	12.5	11.7	10.4	9.4	8.6	9.3	8.2	7.0		
32.0	5.1	6.0	7.0	7.5		8.0	9.5	11.4	12.5	12.4	10.2	11.4	10.1	9.2	8.4	9.2	8.0	6.8		
34.0		3.9	4.8	5.3		6.1	7.4	9.1	10.3	10.9	8.3	10.1	9.8	9.0	8.3	8.8	7.7	6.6	5.7	
36.0						4.3	5.5	7.1	8.1	8.6	6.5	8.2	9.6	8.8	8.2	8.5	7.4	6.4	5.6	
38.0							3.9	5.3	6.2	6.5	5.0	6.5	8.6	8.7	8.1	7.1	7.2	6.2	5.4	5.2
40.0								3.7	4.4			5.0	6.9	8.3	8.1	5.7	7.0	6.0	5.3	5.2
42.0													5.4	6.7	7.3	4.4	6.1	5.8	5.2	5.1
44.0													4.0	5.1	5.6		4.8	5.7	5.1	5.0
46.0														3.7			3.7	5.5	5.1	5.0
48.0																		4.4	5.1	4.9
50.0																			4.6	4.9
θ(°)	58~ 84.5	57~ 84.5	59~ 84.5	60~ 84.5	66~ 84.5	60~ 84.5	60~ 84.5	60~ 84.5	62~ 84.5	65~ 84.5	61~ 84.5	63~ 84.5	64~ 84.5	65~ 84.5	68~ 84.5	61~ 84.5	62~ 84.5	66~ 84.5	68~ 84.5	70~ 84.5
標準フック	35t					35t					35t					12.2t				
フック重量	950kg					950kg					950kg					440kg				
標準巻掛本数	3					2					2					1				

カウンタウエイト 78t、アウトリガ張出幅 6.8m
PS+50.5mブーム+2.3m+フルオートラフィングジブ

単位:t

ジブ長さ(m) 作業半径 (m)	10.3m オフセット					17.2m オフセット					24.1m オフセット					31.0m オフセット				
	5°	15°	30°	45°	60°	5°	15°	30°	45°	60°	5°	15°	30°	45°	60°	5°	15°	30°	45°	60°
11.0	21.0																			
12.0	21.0																			
14.0	21.0	20.4				15.9														
16.0	21.0	19.0	16.7	15.2		15.9	15.6				12.2									
18.0	19.7	17.8	15.7	14.4	13.6	15.9	14.5				12.2					9.0				
20.0	18.4	16.6	14.8	13.7	13.0	15.5	13.6	11.7			12.2	11.5				9.0				
22.0	17.2	15.7	14.0	13.0	12.4	14.5	12.8	11.1	10.0		12.2	10.9				9.0				
24.0	16.1	14.8	13.3	12.4	11.9	13.5	12.1	10.6	9.6	9.0	11.7	10.2				9.0	8.9			
26.0	13.0	13.9	12.7	11.9	11.5	12.7	11.4	10.0	9.2	8.6	10.9	9.7	8.4			9.0	8.7			
28.0	10.1	11.1	12.1	11.4	11.1	12.0	10.8	9.6	8.8	8.3	10.3	9.1	8.0			9.0	8.3			
30.0	7.5	8.5	9.7	10.5	10.7	10.4	10.2	9.1	8.4	8.0	9.7	8.7	7.6	6.9		8.8	7.8	6.8		
32.0	5.3	6.2	7.3	7.9	8.1	8.2	9.6	8.7	8.1	7.8	9.2	8.2	7.2	6.6	6.2	8.4	7.4	6.5		
34.0			5.1	5.7	5.8	6.2	7.6	8.4	7.8	7.5	8.3	7.8	6.9	6.4	5.9	7.9	7.1	6.2		
36.0							5.7	7.3	7.5	7.2	6.5	7.4	6.6	6.0	5.7	7.5	6.7	5.9	5.4	
38.0								5.6	6.6	6.9	5.0	6.6	6.3	5.7	5.4	7.0	6.4	5.6	5.1	4.7
40.0									4.8	5.1		5.1	5.9	5.4	5.1	5.6	6.1	5.3	4.8	4.4
42.0													5.5	5.2	4.9		5.7	5.0	4.5	4.2
44.0														4.9	4.7		4.8	4.7	4.3	4.0
46.0															4.4		4.5	4.1	3.8	
48.0																	4.2	3.8	3.6	
50.0																			3.6	3.5
θ(°)	61~ 84.5	63~ 84.5	62~ 84.5	63~ 84.5	63~ 84.5	63~ 84.5	64~ 84.5	65~ 84.5	65~ 84.5	66~ 84.5	64~ 84.5	65~ 84.5	68~ 84.5	68~ 84.5	68~ 84.5	65~ 84.5	67~ 84.5	68~ 84.5	70~ 84.5	73~ 84.5
標準フック	35t					35t					35t					12.2t				
フック重量	950kg					950kg					950kg					440kg				
標準巻掛本数	2					2					2					1				

カウンタウエイト 78t、アウトリガ張出幅 6.8m
PS+55.6mブーム+2.3m+フルオートラフィングジブ

単位:t

ジブ長さ(m) 作業半径 (m)	10.3m オフセット					17.2m オフセット					24.1m オフセット					31.0m オフセット				
	5°	15°	30°	45°	60°	5°	15°	30°	45°	60°	5°	15°	30°	45°	60°	5°	15°	30°	45°	60°
12.0	15.0																			
14.0	15.0	15.0				11.7														
16.0	15.0	15.0	14.5			11.7														
18.0	15.0	15.0	13.5	12.6	11.9	11.7	11.7				8.8									
20.0	15.0	13.9	12.6	11.8	11.3	11.7	11.7				8.8					6.8				
22.0	14.0	13.0	11.9	11.1	10.7	11.7	10.9	9.7			8.8	8.8				6.8				
24.0	13.0	12.1	11.1	10.5	10.1	11.2	10.2	9.1	8.4		8.8	8.8				6.8				
26.0	12.1	11.3	10.5	9.9	9.5	10.5	9.6	8.6	8.0	7.6	8.8	8.7	7.7			6.8	6.8			
28.0	10.7	10.5	9.7	9.2	8.8	9.8	9.0	8.1	7.5	7.1	8.8	8.1	7.2			6.8	6.8			
30.0	8.1	9.1	9.0	8.5	8.2	9.0	8.2	7.5	6.9	6.6	8.4	7.7	6.8	6.3		6.8	6.8			
32.0	5.9	6.8	7.9	7.9	7.6	8.2	7.6	6.9	6.4	6.1	7.7	7.0	6.3	5.8	5.5	6.8	6.5	5.7		
34.0			5.8	6.4	6.6	6.3	7.0	6.4	6.0	5.7	7.1	6.5	5.8	5.4	5.1	6.5	5.9	5.3		
36.0							5.9	5.9	5.5	5.3	6.5	6.0	5.4	5.0	4.7	6.0	5.5	4.9	4.5	
38.0								5.4	5.1	4.9	5.3	5.5	5.0	4.6	4.4	5.5	5.0	4.5	4.2	
40.0									4.7	4.6		5.0	4.6	4.3	4.1	5.0	4.6	4.2	3.9	3.7
42.0													4.2	4.0	3.8		4.2	3.8	3.6	3.4
44.0														3.7	3.5			3.5	3.3	3.1
46.0															3.2			3.2	3.0	2.9
48.0																			2.8	2.7
50.0																			2.5	2.4
θ(°)	64~ 84.5	65~ 84.5	65~ 84.5	66~ 84.5	67~ 84.5	66~ 84.5	67~ 84.5	68~ 84.5	68~ 84.5	68~ 84.5	66~ 84.5	68~ 84.5	70~ 84.5	71~ 84.5	71~ 84.5	69~ 84.5	70~ 84.5	72~ 84.5	73~ 84.5	75~ 84.5
標準フック	35t										12.2t									
フック重量	950kg										440kg									
標準巻掛本数	2										1									

PS+FLJ

カウンタウエイト 78t、アウトリガ張出幅 6.8m
PS+60.0mブーム+2.3m+フルオートラフィングジブ

単位:t

ジブ長さ(m) 作業半径 (m)	10.3m オフセット					17.2m オフセット					24.1m オフセット					31.0m オフセット				
	5°	15°	30°	45°	60°	5°	15°	30°	45°	60°	5°	15°	30°	45°	60°	5°	15°	30°	45°	60°
14.0	11.5																			
16.0	11.5	11.5				8.7														
18.0	11.5	11.5	11.5	11.5		8.7	8.7				6.8									
20.0	11.5	11.5	11.5	11.0	10.5	8.7	8.7				6.8					5.3				
22.0	11.5	11.5	11.0	10.4	9.9	8.7	8.7	8.7			6.8	6.8				5.3				
24.0	11.5	11.3	10.2	9.5	9.2	8.7	8.7	8.4			6.8	6.8				5.3				
26.0	11.2	10.4	9.3	8.7	8.4	8.7	8.7	7.6	7.0	6.6	6.8	6.8				5.3	5.3			
28.0	10.3	9.4	8.5	7.9	7.7	8.7	8.0	7.0	6.4	6.1	6.8	6.8	5.9			5.3	5.3			
30.0	7.9	8.5	7.7	7.3	7.1	8.1	7.2	6.4	5.9	5.6	6.8	6.2	5.4			5.3	5.3			
32.0			7.0	6.6	6.5	7.3	6.6	5.8	5.4	5.2	6.3	5.6	4.9	4.5		5.3	5.0			
34.0				6.0	5.9		5.9	5.3	4.9	4.8	5.7	5.1	4.5	4.1	3.9	5.1	4.5	4.0		
36.0								4.8	4.5	4.4	5.1	4.6	4.1	3.8	3.6	4.6	4.1	3.6		
38.0								4.4	4.1	4.0		4.2	3.7	3.5	3.3	4.2	3.7	3.3	3.0	
40.0										3.7			3.4	3.1	3.0		3.4	3.0	2.8	
42.0													3.0	2.8	2.8			2.7	2.5	2.4
44.0														2.6	2.5			2.4	2.3	2.2
46.0																			2.0	2.0
48.0																			1.8	1.8
50.0																			1.8	1.6
θ(°)	68~ 84.5	70~ 84.5	69~ 84.5	69~ 84.5	69~ 84.5	70~ 84.5	71~ 84.5	70~ 84.5	72~ 84.5	71~ 84.5	70~ 84.5	71~ 84.5	72~ 84.5	73~ 84.5	75~ 84.5	72~ 84.5	74~ 84.5	76~ 84.5	76~ 84.5	77~ 84.5
標準フック											12.2t									
フック重量											440kg									
標準巻掛本数											1									

PS+フルオートラフィングジブ

カウンタウエイト 58t、アウトリガ張出幅 8.5m
PS+40.4mブーム+2.3m+フルオートラフィングジブ

単位:t

ジブ長さ(m) 作業半径 (m)	10.3m オフセット					17.2m オフセット					24.1m オフセット					31.0m オフセット				
	5°	15°	30°	45°	60°	5°	15°	30°	45°	60°	5°	15°	30°	45°	60°	5°	15°	30°	45°	60°
9.0	37.6																			
10.0	37.6					16.7														
11.0	37.6	37.6				16.7														
12.0	37.6	37.6				16.7														
14.0	37.6	37.6	30.3	25.6		16.7	16.7				16.4									
16.0	36.3	35.0	29.0	24.8	22.8	16.7	16.7				16.0					10.9				
18.0	30.8	30.8	27.8	24.2	22.4	16.7	16.7	16.7			15.6	14.0				10.9				
20.0	24.6	26.0	26.6	23.5	22.1	16.7	16.7	16.7	14.9		15.2	13.6				10.7				
22.0	19.9	21.1	22.6	23.0	21.9	16.7	16.7	16.7	14.5	13.1	14.7	13.1	11.6			10.5	9.7			
24.0	15.7	17.0	18.4	19.4	19.8	16.7	16.7	16.3	14.1	12.9	14.2	12.7	11.3			10.3	9.3			
26.0	12.1	13.3	14.7	15.7	16.0	15.6	16.7	15.7	13.7	12.7	13.7	12.3	11.0	9.8		10.0	8.9			
28.0	9.1	10.1	11.4	12.2	12.4	12.5	14.2	15.2	13.4	12.5	13.2	12.0	10.6	9.6		9.8	8.5	7.2		
30.0	6.5	7.4	8.5	9.1		9.9	11.5	13.5	13.1	12.4	12.3	11.7	10.3	9.3	8.5	9.5	8.2	7.0		
32.0		5.1	6.0	6.5		7.6	9.0	10.9	12.2	12.3	10.0	11.4	10.1	9.1	8.4	9.1	7.9	6.7		
34.0				4.2		5.6	6.9	8.5	9.7	10.2	8.0	9.8	9.8	8.9	8.3	8.7	7.6	6.5	5.7	
36.0						3.9	5.0	6.5	7.5	7.8	6.3	7.9	9.5	8.8	8.2	8.4	7.4	6.3	5.6	5.3
38.0							3.4	4.7	5.5		4.7	6.2	8.2	8.6	8.1	6.9	7.1	6.1	5.4	5.2
40.0									3.7			4.7	6.5	7.9	8.1	5.5	6.9	5.9	5.3	5.1
42.0												3.3	5.0	6.1	6.6	4.2	5.9	5.8	5.2	5.1
44.0													3.6	4.6			4.6	5.6	5.2	5.0
46.0																3.4	5.3	5.1	5.0	
48.0																	4.1	5.1	5.0	
50.0																		4.1	4.6	
θ(°)	57~ 84.5	56~ 84.5	58~ 84.5	55~ 84.5	64~ 84.5	56~ 84.5	56~ 84.5	59~ 84.5	58~ 84.5	65~ 84.5	58~ 84.5	58~ 84.5	59~ 84.5	62~ 84.5	66~ 84.5	59~ 84.5	59~ 84.5	63~ 84.5	64~ 84.5	66~ 84.5
標準フック	80t					35t					12.2t									
フック重量	1550kg					950kg					440kg									
標準巻掛本数	4					2					1									

カウンタウエイト 58t、アウトリガ張出幅 8.5m
PS+45.4mブーム+2.3m+フルオートラフィングジブ

単位:t

ジブ長さ(m) 作業半径 (m)	10.3m オフセット					17.2m オフセット					24.1m オフセット					31.0m オフセット				
	5°	15°	30°	45°	60°	5°	15°	30°	45°	60°	5°	15°	30°	45°	60°	5°	15°	30°	45°	60°
10.0	28.6																			
11.0	28.6																			
12.0	28.6	28.6				16.7														
14.0	28.6	28.6	28.6			16.7					15.5									
16.0	28.6	28.6	28.6	25.2	23.0	16.7	16.7				15.3									
18.0	28.6	28.6	28.1	24.6	22.7	16.7	16.7				14.9	13.9				10.5				
20.0	24.9	25.5	24.9	24.0	22.4	16.7	16.7	16.7			14.7	13.5				10.3				
22.0	20.1	21.3	22.1	22.0	22.0	16.7	16.7	16.7	14.6		14.4	13.1				10.1	9.5			
24.0	15.9	17.3	18.7	19.6	19.7	16.7	16.7	16.6	14.2	12.9	14.1	12.7	11.3			9.9	9.2			
26.0	12.3	13.5	15.0	16.1	16.5	15.4	16.7	16.1	13.9	12.7	13.7	12.3	11.0			9.7	8.9			
28.0	9.3	10.4	11.7	12.6	13.0	12.4	14.2	15.1	13.6	12.6	13.3	12.0	10.6	9.6		9.5	8.6			
30.0	6.7	7.7	8.9	9.6	9.8	9.8	11.4	13.5	13.3	12.5	12.1	11.7	10.4	9.4	8.6	9.3	8.2	7.0		
32.0		5.4	6.4	7.0		7.5	9.0	10.9	12.4	12.4	9.8	11.4	10.1	9.2	8.4	9.2	8.0	6.8		
34.0				4.7		5.5	6.9	8.6	9.9	10.5	7.8	9.6	9.8	9.0	8.3	8.8	7.7	6.6	5.7	
36.0							5.0	6.6	7.7	8.1	6.0	7.7	9.6	8.8	8.2	8.2	7.4	6.4	5.6	
38.0								4.8	5.7	6.0	4.5	6.0	8.1	8.7	8.1	6.6	7.2	6.2	5.4	5.2
40.0												4.5	6.5	7.9	8.1	5.2	7.0	6.0	5.3	5.2
42.0													4.9	6.2	6.9		5.6	5.8	5.2	5.1
44.0														4.7	5.2		4.4	5.7	5.1	5.0
46.0																		5.2	5.1	5.0
48.0																		4.0	5.1	4.9
50.0																			4.2	4.8
θ(°)	60~ 84.5	60~ 84.5	62~ 84.5	60~ 84.5	66~ 84.5	62~ 84.5	62~ 84.5	62~ 84.5	64~ 84.5	65~ 84.5	61~ 84.5	63~ 84.5	66~ 84.5	67~ 84.5	68~ 84.5	63~ 84.5	64~ 84.5	66~ 84.5	68~ 84.5	70~ 84.5
標準フック	35t					35t					12.2t									
フック重量	950kg					950kg					440kg									
標準巻掛本数	3					2					1									

カウンタウエイト 58t、アウトリガ張出幅 8.5m
PS+50.5mブーム+2.3m+フルオートラフィングジブ

単位:t

ジブ長さ(m) 作業半径 (m)	10.3m オフセット					17.2m オフセット					24.1m オフセット					31.0m オフセット				
	5°	15°	30°	45°	60°	5°	15°	30°	45°	60°	5°	15°	30°	45°	60°	5°	15°	30°	45°	60°
11.0	21.0																			
12.0	21.0																			
14.0	21.0	20.4				15.9														
16.0	21.0	19.0	16.7	15.2		15.9	15.6				12.2									
18.0	19.7	17.8	15.7	14.4	13.6	15.9	14.5				12.2					9.0				
20.0	18.4	16.6	14.8	13.7	13.0	15.5	13.6	11.7			12.2	11.5				9.0				
22.0	17.2	15.7	14.0	13.0	12.4	14.5	12.8	11.1	10.0		12.2	10.9				9.0				
24.0	16.1	14.8	13.3	12.4	11.9	13.5	12.1	10.6	9.6	9.0	11.7	10.2				9.0	8.9			
26.0	12.5	13.7	12.7	11.9	11.5	12.7	11.4	10.0	9.2	8.6	10.9	9.7	8.4			9.0	8.7			
28.0	9.5	10.6	12.0	11.4	11.1	12.0	10.8	9.6	8.8	8.3	10.3	9.1	8.0			9.0	8.3			
30.0	6.9	7.9	9.2	10.0	10.3	9.9	10.2	9.1	8.4	8.0	9.7	8.7	7.6	6.9		8.8	7.8	6.8		
32.0		5.6	6.7	7.4	7.6	7.6	9.2	8.7	8.1	7.8	9.2	8.2	7.2	6.6	6.2	8.4	7.4	6.5		
34.0				5.2	5.3	5.7	7.1	8.4	7.8	7.5	7.8	7.8	6.9	6.4	5.9	7.9	7.1	6.2		
36.0							5.2	6.8	7.5	7.2	6.0	7.4	6.6	6.0	5.7	7.5	6.7	5.9	5.4	
38.0								5.1	6.1	6.5		6.1	6.3	5.7	5.4	6.5	6.4	5.6	5.1	4.7
40.0													5.9	5.4	5.1	5.1	6.1	5.3	4.8	4.4
42.0													5.1	5.2	4.9		5.6	5.0	4.5	4.2
44.0														4.9	4.7			4.7	4.3	4.0
46.0																		4.5	4.1	3.8
48.0																			3.8	3.6
50.0																				3.5
θ (°)	63~ 84.5	63~ 84.5	64~ 84.5	63~ 84.5	63~ 84.5	63~ 84.5	64~ 84.5	65~ 84.5	67~ 84.5	68~ 84.5	65~ 84.5	67~ 84.5	68~ 84.5	68~ 84.5	70~ 84.5	65~ 84.5	68~ 84.5	70~ 84.5	72~ 84.5	73~ 84.5
標準フック	35t										12.2t									
フック重量	950kg										440kg									
標準巻掛本数	2										1									

PS+FLJ

カウンタウエイト 58t、アウトリガ張出幅 8.5m
PS+55.6mブーム+2.3m+フルオートラフィングジブ

単位:t

ジブ長さ(m) 作業半径 (m)	10.3m オフセット					17.2m オフセット					24.1m オフセット					31.0m オフセット				
	5°	15°	30°	45°	60°	5°	15°	30°	45°	60°	5°	15°	30°	45°	60°	5°	15°	30°	45°	60°
12.0	15.0																			
14.0	15.0	15.0				11.7														
16.0	15.0	15.0	14.5			11.7														
18.0	15.0	15.0	13.5	12.6	11.9	11.7	11.7				8.8									
20.0	15.0	13.9	12.6	11.8	11.3	11.7	11.7				8.8					6.8				
22.0	14.0	13.0	11.9	11.1	10.7	11.7	10.9	9.7			8.8	8.8				6.8				
24.0	13.0	12.1	11.1	10.5	10.1	11.2	10.2	9.1	8.4		8.8	8.8				6.8				
26.0	12.1	11.3	10.5	9.9	9.5	10.5	9.6	8.6	8.0	7.6	8.8	8.7	7.7			6.8	6.8			
28.0	10.2	10.5	9.7	9.2	8.8	9.8	9.0	8.1	7.5	7.1	8.8	8.1	7.2			6.8	6.8			
30.0	7.6	8.6	9.0	8.5	8.2	9.0	8.2	7.5	6.9	6.6	8.4	7.7	6.8	6.3		6.8	6.8			
32.0			7.4	7.9	7.6	7.8	7.6	6.9	6.4	6.1	7.7	7.0	6.3	5.8	5.5	6.8	6.5	5.7		
34.0					6.1		7.0	6.4	6.0	5.7	7.1	6.5	5.8	5.4	5.1	6.5	5.9	5.3		
36.0								5.9	5.5	5.3	6.4	6.0	5.4	5.0	4.7	6.0	5.5	4.9	4.5	
38.0									5.1	4.9		5.5	5.0	4.6	4.4	5.5	5.0	4.5	4.2	
40.0													4.6	4.3	4.1		4.6	4.2	3.9	3.7
42.0													4.2	4.0	3.8		4.2	3.8	3.6	3.4
44.0														3.7	3.5			3.5	3.3	3.1
46.0																		3.2	3.0	2.9
48.0																			2.8	2.7
50.0																				2.4
θ (°)	66~ 84.5	67~ 84.5	67~ 84.5	68~ 84.5	67~ 84.5	68~ 84.5	68~ 84.5	70~ 84.5	70~ 84.5	70~ 84.5	68~ 84.5	70~ 84.5	70~ 84.5	71~ 84.5	73~ 84.5	70~ 84.5	70~ 84.5	72~ 84.5	74~ 84.5	75~ 84.5
標準フック	35t										12.2t									
フック重量	950kg										440kg									
標準巻掛本数	2										1									

PS+フルオートラフィングジブ

カウンタウエイト 58t、アウトリガ張出幅 8.5m
PS+60.0mブーム+2.3m+フルオートラフィングジブ

単位:t

ジブ長さ(m) 作業半径 (m)	10.3m オフセット					17.2m オフセット					24.1m オフセット					31.0m オフセット				
	5°	15°	30°	45°	60°	5°	15°	30°	45°	60°	5°	15°	30°	45°	60°	5°	15°	30°	45°	60°
14.0	11.5																			
16.0	11.5	11.5				8.7														
18.0	11.5	11.5	11.5	11.5		8.7	8.7						6.8							
20.0	11.5	11.5	11.5	11.0	10.5	8.7	8.7						6.8					5.3		
22.0	11.5	11.5	11.0	10.4	9.9	8.7	8.7	8.7					6.8	6.8				5.3		
24.0	11.5	11.3	10.2	9.5	9.2	8.7	8.7	8.4					6.8	6.8				5.3		
26.0	11.2	10.4	9.3	8.7	8.4	8.7	8.7	7.6	7.0	6.6	6.8	6.8					5.3	5.3		
28.0	10.0	9.4	8.5	7.9	7.7	8.7	8.0	7.0	6.4	6.1	6.8	6.8	5.9				5.3	5.3		
30.0		8.4	7.7	7.3	7.1	8.1	7.2	6.4	5.9	5.6	6.8	6.2	5.4				5.3	5.3		
32.0			7.0	6.6	6.5	7.3	6.6	5.8	5.4	5.2	6.3	5.6	4.9	4.5			5.3	5.0		
34.0							5.9	5.3	4.9	4.8	5.7	5.1	4.5	4.1	3.9		5.1	4.5	4.0	
36.0								4.8	4.5	4.4		4.6	4.1	3.8	3.6		4.6	4.1	3.6	
38.0									4.1	4.0							3.7	3.3	3.0	
40.0																	3.4	3.1	3.0	2.8
42.0																		2.8	2.8	
44.0																		2.5		
46.0																				2.0
48.0																				1.8
θ(°)	70~ 84.5	70~ 84.5	69~ 84.5	70~ 84.5	71~ 84.5	70~ 84.5	71~ 84.5	72~ 84.5	72~ 84.5	73~ 84.5	72~ 84.5	74~ 84.5	74~ 84.5	75~ 84.5	75~ 84.5	73~ 84.5	74~ 84.5	76~ 84.5	78~ 84.5	79~ 84.5
標準フック											12.2t									
フック重量											440kg									
標準巻掛本数											1									

カウンタウエイト 58t、アウトリガ張出幅 8.0m
PS+40.4mブーム+2.3m+フルオートラフィングジブ

単位:t

ジブ長さ(m) 作業半径 (m)	10.3m オフセット					17.2m オフセット					24.1m オフセット					31.0m オフセット				
	5°	15°	30°	45°	60°	5°	15°	30°	45°	60°	5°	15°	30°	45°	60°	5°	15°	30°	45°	60°
9.0	37.6																			
10.0	37.6					16.7														
11.0	37.6	37.6				16.7														
12.0	37.6	37.6				16.7														
14.0	37.6	37.6	30.3	25.6		16.7	16.7						16.4							
16.0	36.3	35.0	29.0	24.8	22.8	16.7	16.7						16.0					10.9		
18.0	28.8	30.5	27.8	24.2	22.4	16.7	16.7	16.7					15.6	14.0				10.9		
20.0	22.8	24.2	26.1	23.5	22.1	16.7	16.7	16.7	14.9				15.2	13.6				10.7		
22.0	18.1	19.4	21.0	22.1	21.9	16.7	16.7	16.7	14.5	13.1			14.7	13.1	11.6			10.5	9.7	
24.0	13.9	15.2	16.9	17.8	18.3	16.7	16.7	16.3	14.1	12.9			14.2	12.7	11.3			10.3	9.3	
26.0	10.4	11.6	13.1	14.1	14.4	14.0	15.8	15.7	13.7	12.7			13.7	12.3	11.0	9.8		10.0	8.9	
28.0	7.6	8.6	9.9	10.7	10.9	11.0	12.7	14.8	13.4	12.5			13.2	12.0	10.6	9.6		9.8	8.5	7.2
30.0	5.1	6.0	7.1	7.7		8.5	10.1	12.1	13.1	12.4			10.9	11.7	10.3	9.3	8.5	9.5	8.2	7.0
32.0			4.7	5.2		6.3	7.7	9.6	10.9	11.6			8.7	10.7	10.1	9.1	8.4	9.1	7.9	6.7
34.0						4.4	5.7	7.4	8.5	9.0			6.8	8.6	9.8	8.9	8.3	8.7	7.6	6.5
36.0							4.0	5.4	6.4	6.7			5.2	6.8	9.0	8.8	8.2	7.4	7.4	6.3
38.0								3.6	4.4					5.2	7.1	8.6	8.1	5.9	7.1	6.1
40.0														3.7	5.5	6.9	7.5	4.5	6.3	5.9
42.0															4.0	5.2	5.7		4.9	5.8
44.0																3.7			3.7	5.6
46.0																			4.5	5.1
48.0																				4.6
50.0																				3.8
θ(°)	57~ 84.5	58~ 84.5	58~ 84.5	58~ 84.5	64~ 84.5	59~ 84.5	58~ 84.5	59~ 84.5	61~ 84.5	65~ 84.5	60~ 84.5	60~ 84.5	62~ 84.5	62~ 84.5	66~ 84.5	60~ 84.5	61~ 84.5	65~ 84.5	67~ 84.5	66~ 84.5
標準フック	80t										35t									
フック重量	1550kg										950kg									
標準巻掛本数	4										2									

カウンタウエイト 58t、アウトリガ張出幅 8.0m
PS+45.4mブーム+2.3m+フルオートラフingジブ

単位:t

ジブ長さ(m) 作業半径 (m)	10.3m オフセット					17.2m オフセット					24.1m オフセット					31.0m オフセット				
	5°	15°	30°	45°	60°	5°	15°	30°	45°	60°	5°	15°	30°	45°	60°	5°	15°	30°	45°	60°
10.0	28.6																			
11.0	28.6																			
12.0	28.6	28.6				16.7														
14.0	28.6	28.6	28.6			16.7					15.5									
16.0	28.6	28.6	28.6	25.2	23.0	16.7	16.7				15.3									
18.0	28.6	28.6	28.1	24.6	22.7	16.7	16.7				14.9	13.9				10.5				
20.0	23.1	24.5	24.9	24.0	22.4	16.7	16.7	16.7			14.7	13.5				10.3				
22.0	18.4	19.6	21.3	22.0	22.0	16.7	16.7	16.7	14.6		14.4	13.1				10.1	9.5			
24.0	14.1	15.5	17.2	18.2	18.7	16.7	16.7	16.6	14.2	12.9	14.1	12.7	11.3			9.9	9.2			
26.0	10.7	11.9	13.4	14.5	15.0	13.8	15.7	16.1	13.9	12.7	13.7	12.3	11.0			9.7	8.9			
28.0	7.8	8.9	10.2	11.1	11.4	10.9	12.7	14.9	13.6	12.6	13.2	12.0	10.6	9.6		9.5	8.6			
30.0	5.4	6.3	7.5	8.2	8.4	8.4	10.0	12.2	13.3	12.5	10.7	11.7	10.4	9.4	8.6	9.3	8.2	7.0		
32.0			5.1	5.7		6.2	7.7	9.6	11.1	11.9	8.5	10.5	10.1	9.2	8.4	9.2	8.0	6.8		
34.0							5.7				6.6	8.4	9.8	9.0	8.3	8.8	7.7	6.6	5.7	
36.0								5.5	6.6	7.0	4.9	6.6	8.9	8.8	8.2	7.1	7.4	6.4	5.6	
38.0									4.7	5.0		5.0	7.1	8.7	8.1	5.6	7.2	6.2	5.4	5.2
40.0													5.5	6.9	7.8		6.0	6.0	5.3	5.2
42.0														5.3	6.0		4.7	5.8	5.2	5.1
44.0																		5.6	5.1	5.0
46.0																		4.4	5.1	5.0
48.0																			4.6	4.9
θ (°)	60~ 84.5	62~ 84.5	62~ 84.5	63~ 84.5	66~ 84.5	64~ 84.5	64~ 84.5	65~ 84.5	64~ 84.5	65~ 84.5	63~ 84.5	65~ 84.5	68~ 84.5	69~ 84.5	71~ 84.5	65~ 84.5	66~ 84.5	68~ 84.5	70~ 84.5	72~ 84.5
標準フック	35t					35t					12.2t									
フック重量	950kg					950kg					440kg									
標準巻掛本数	3					2					1									

PS+FLJ

カウンタウエイト 58t、アウトリガ張出幅 8.0m
PS+50.5mブーム+2.3m+フルオートラフingジブ

単位:t

ジブ長さ(m) 作業半径 (m)	10.3m オフセット					17.2m オフセット					24.1m オフセット					31.0m オフセット				
	5°	15°	30°	45°	60°	5°	15°	30°	45°	60°	5°	15°	30°	45°	60°	5°	15°	30°	45°	60°
11.0	21.0																			
12.0	21.0																			
14.0	21.0	20.4				15.9														
16.0	21.0	19.0	16.7	15.2		15.9	15.6				12.2									
18.0	19.7	17.8	15.7	14.4	13.6	15.9	14.5				12.2					9.0				
20.0	18.4	16.6	14.8	13.7	13.0	15.5	13.6	11.7			12.2	11.5				9.0				
22.0	17.2	15.7	14.0	13.0	12.4	14.5	12.8	11.1	10.0		12.2	10.9				9.0				
24.0	14.3	14.8	13.3	12.4	11.9	13.5	12.1	10.6	9.6	9.0	11.7	10.2				9.0	8.9			
26.0	10.9	12.1	12.7	11.9	11.5	12.7	11.4	10.0	9.2	8.6	10.9	9.7	8.4			9.0	8.7			
28.0	8.0	9.1	10.5	11.4	11.1	11.0	10.8	9.6	8.8	8.3	10.3	9.1	8.0			9.0	8.3			
30.0		6.6	7.8	8.6	8.9	8.5	10.2	9.1	8.4	8.0	9.7	8.7	7.6	6.9		8.8	7.8	6.8		
32.0			5.4	6.1	6.3	6.4	7.9	8.7	8.1	7.8	8.5	8.2	7.2	6.6	6.2	8.4	7.4	6.5		
34.0							5.9	7.7	7.8	7.5	6.6	7.8	6.9	6.4	5.9	7.9	7.1	6.2		
36.0								5.7	6.9	7.2		6.7	6.6	6.0	5.7	7.0	6.7	5.9	5.4	
38.0										5.5			6.3	5.7	5.4	5.5	6.4	5.6	5.1	4.7
40.0													5.6	5.4	5.1		6.0	5.3	4.8	4.4
42.0														5.2	4.9			5.0	4.5	4.2
44.0																		4.7	4.3	4.0
46.0																			4.1	3.8
48.0																				3.6
θ (°)	65~ 84.5	65~ 84.5	64~ 84.5	66~ 84.5	66~ 84.5	65~ 84.5	66~ 84.5	67~ 84.5	69~ 84.5	68~ 84.5	67~ 84.5	69~ 84.5	69~ 84.5	70~ 84.5	72~ 84.5	67~ 84.5	70~ 84.5	72~ 84.5	74~ 84.5	75~ 84.5
標準フック	35t					35t					12.2t									
フック重量	950kg					950kg					440kg									
標準巻掛本数	2					2					1									

PS+フルオートラフィングジブ

カウンタウエイト 58t、アウトリガ張出幅 8.0m
PS+55.6mブーム+2.3m+フルオートラフィングジブ

単位:t

ジブ長さ(m) 作業半径 (m)	10.3m オフセット					17.2m オフセット					24.1m オフセット					31.0m オフセット				
	5°	15°	30°	45°	60°	5°	15°	30°	45°	60°	5°	15°	30°	45°	60°	5°	15°	30°	45°	60°
12.0	15.0																			
14.0	15.0	15.0				11.7														
16.0	15.0	15.0	14.5			11.7														
18.0	15.0	15.0	13.5	12.6	11.9	11.7	11.7				8.8									
20.0	15.0	13.9	12.6	11.8	11.3	11.7	11.7				8.8					6.8				
22.0	14.0	13.0	11.9	11.1	10.7	11.7	10.9	9.7			8.8	8.8				6.8				
24.0	13.0	12.1	11.1	10.5	10.1	11.2	10.2	9.1	8.4		8.8	8.8				6.8				
26.0	11.5	11.3	10.5	9.9	9.5	10.5	9.6	8.6	8.0	7.6	8.8	8.7	7.7			6.8	6.8			
28.0	8.7	9.8	9.7	9.2	8.8	9.8	9.0	8.1	7.5	7.1	8.8	8.1	7.2			6.8	6.8			
30.0		7.2	8.5	8.5	8.2	8.6	8.2	7.5	6.9	6.6	8.4	7.7	6.8	6.3		6.8	6.8			
32.0				6.9	7.1		7.6	6.9	6.4	6.1	7.7	7.0	6.3	5.8	5.5	6.8	6.5	5.7		
34.0								6.4	6.0	5.7	7.0	6.5	5.8	5.4	5.1	6.5	5.9	5.3		
36.0									5.5	5.3		6.0	5.4	5.0	4.7	6.0	5.5	4.9	4.5	
38.0										4.9			5.0	4.6	4.4		5.0	4.5	4.2	
40.0													4.6	4.3	4.1		4.6	4.2	3.9	3.7
42.0														4.0	3.8			3.8	3.6	3.4
44.0																		3.5	3.3	3.1
46.0																			3.0	2.9
48.0																				2.7
θ(°)	68~ 84.5	67~ 84.5	69~ 84.5	68~ 84.5	69~ 84.5	69~ 84.5	70~ 84.5	71~ 84.5	72~ 84.5	70~ 84.5	70~ 84.5	71~ 84.5	72~ 84.5	73~ 84.5	75~ 84.5	72~ 84.5	72~ 84.5	74~ 84.5	76~ 84.5	77~ 84.5
標準フック											12.2t									
フック重量						950kg					440kg									
標準巻掛本数											1									

カウンタウエイト 58t、アウトリガ張出幅 8.0m
PS+60.0mブーム+2.3m+フルオートラフィングジブ

単位:t

ジブ長さ(m) 作業半径 (m)	10.3m オフセット					17.2m オフセット					24.1m オフセット					31.0m オフセット				
	5°	15°	30°	45°	60°	5°	15°	30°	45°	60°	5°	15°	30°	45°	60°	5°	15°	30°	45°	60°
14.0	11.5																			
16.0	11.5	11.5				8.7														
18.0	11.5	11.5	11.5	11.5		8.7	8.7				6.8									
20.0	11.5	11.5	11.5	11.0	10.5	8.7	8.7				6.8					5.3				
22.0	11.5	11.5	11.0	10.4	9.9	8.7	8.7	8.7			6.8	6.8				5.3				
24.0	11.5	11.3	10.2	9.5	9.2	8.7	8.7	8.4			6.8	6.8				5.3				
26.0	11.2	10.4	9.3	8.7	8.4	8.7	8.7	7.6	7.0	6.6	6.8	6.8				5.3	5.3			
28.0		9.4	8.5	7.9	7.7	8.7	8.0	7.0	6.4	6.1	6.8	6.8	5.9			5.3	5.3			
30.0			7.7	7.3	7.1	8.1	7.2	6.4	5.9	5.6	6.8	6.2	5.4			5.3	5.3			
32.0							6.6	5.8	5.4	5.2	6.3	5.6	4.9	4.5		5.3	5.0			
34.0								5.3	4.9	4.8		5.1	4.5	4.1	3.9	5.1	4.5	4.0		
36.0									4.5	4.4			4.1	3.8	3.6		4.1	3.6		
38.0													3.7	3.5	3.3		3.7	3.3	3.0	
40.0														3.1	3.0			3.0	2.8	
42.0															2.8			2.7	2.5	2.4
44.0																			2.3	2.2
46.0																				2.0
θ(°)	72~ 84.5	71~ 84.5	71~ 84.5	72~ 84.5	73~ 84.5	72~ 84.5	72~ 84.5	73~ 84.5	74~ 84.5	75~ 84.5	73~ 84.5	74~ 84.5	75~ 84.5	76~ 84.5	77~ 84.5	74~ 84.5	75~ 84.5	77~ 84.5	79~ 84.5	80~ 84.5
標準フック											12.2t									
フック重量						440kg					440kg									
標準巻掛本数											1									

カウンタウエイト 58t、アウトリガ張出幅 6.8m
PS+40.4mブーム+2.3m+フルオートラフィングジブ

単位:t

ジブ長さ(m) 作業半径 (m)	10.3m オフセット					17.2m オフセット					24.1m オフセット					31.0m オフセット				
	5°	15°	30°	45°	60°	5°	15°	30°	45°	60°	5°	15°	30°	45°	60°	5°	15°	30°	45°	60°
9.0	37.6																			
10.0	37.6					16.7														
11.0	37.6	37.6				16.7														
12.0	37.6	37.6				16.7														
14.0	37.6	37.6	30.3	25.6		16.7	16.7				16.4									
16.0	29.5	31.4	29.0	24.8	22.8	16.7	16.7				16.0					10.9				
18.0	22.8	24.4	26.5	24.2	22.4	16.7	16.7	16.7			15.6	14.0				10.9				
20.0	17.7	19.1	20.9	22.3	22.1	16.7	16.7	16.7	14.9		15.2	13.6				10.7				
22.0	13.2	14.7	16.5	17.6	18.2	16.7	16.7	16.7	14.5	13.1	14.7	13.1	11.6			10.5	9.7			
24.0	9.6	10.9	12.5	13.7	14.2	13.1	15.1	16.3	14.1	12.9	14.2	12.7	11.3			10.3	9.3			
26.0	6.6	7.7	9.2	10.1	10.5	10.0	11.9	14.3	13.7	12.7	12.5	12.3	11.0	9.8		10.0	8.9			
28.0			6.3	7.1	7.3	7.4	9.1	11.4	13.1	12.5	9.9	12.0	10.6	9.6		9.8	8.5	7.2		
30.0						5.2	6.8	8.8	10.4	11.2	7.6	9.7	10.3	9.3	8.5	9.5	8.2	7.0		
32.0								6.5	7.9	8.5	5.7	7.6	10.1	9.1	8.4	8.0	7.9	6.7		
34.0									5.7	6.2		5.8	8.2	8.9	8.3	6.3	7.6	6.5	5.7	
36.0													6.3	8.1	8.2	4.8	6.8	6.3	5.6	5.3
38.0													4.7	6.2	7.1		5.3	6.1	5.4	5.2
40.0														4.5	5.2			5.9	5.3	5.1
42.0																		4.9	5.2	5.1
44.0																			5.2	5.0
46.0																				4.8
θ(°)	62~ 84.5	64~ 84.5	63~ 84.5	64~ 84.5	64~ 84.5	63~ 84.5	66~ 84.5	67~ 84.5	67~ 84.5	68~ 84.5	64~ 84.5	66~ 84.5	66~ 84.5	67~ 84.5	69~ 84.5	64~ 84.5	67~ 84.5	69~ 84.5	71~ 84.5	72~ 84.5
標準フック	80t					35t					12.2t									
フック重量	1550kg					950kg					440kg									
標準巻掛本数	4					2					1									

PS+FLJ

カウンタウエイト 58t、アウトリガ張出幅 6.8m
PS+45.4mブーム+2.3m+フルオートラフィングジブ

単位:t

ジブ長さ(m) 作業半径 (m)	10.3m オフセット					17.2m オフセット					24.1m オフセット					31.0m オフセット				
	5°	15°	30°	45°	60°	5°	15°	30°	45°	60°	5°	15°	30°	45°	60°	5°	15°	30°	45°	60°
10.0	28.6																			
11.0	28.6																			
12.0	28.6	28.6				16.7														
14.0	28.6	28.6	28.6			16.7					15.5									
16.0	28.6	28.6	28.6	25.2	23.0	16.7	16.7				15.3									
18.0	23.0	24.7	26.8	24.6	22.7	16.7	16.7				14.9	13.9				10.5				
20.0	17.9	19.4	21.2	22.6	22.4	16.7	16.7	16.7			14.7	13.5				10.3				
22.0	13.4	15.0	16.8	18.0	18.6	16.6	16.7	16.7	14.6		14.4	13.1				10.1	9.5			
24.0	9.8	11.1	12.9	14.1	14.7	13.0	15.1	16.6	14.2	12.9	14.1	12.7	11.3			9.9	9.2			
26.0	6.8	8.0	9.5	10.5	11.0	9.9	11.9	14.3	13.9	12.7	12.2	12.3	11.0			9.7	8.9			
28.0			6.7	7.6	7.9	7.3	9.1	11.5	13.1	12.6	9.6	12.0	10.6	9.6		9.5	8.6			
30.0							6.7	8.9	10.5	11.5	7.4	9.6	10.4	9.4	8.6	9.3	8.2	7.0		
32.0								6.6	8.0	8.8		7.5	10.1	9.2	8.4	7.7	8.0	6.8		
34.0									5.9	6.5			8.1	9.0	8.3	6.0	7.7	6.6	5.7	
36.0													6.3	8.1	8.2		6.5	6.4	5.6	
38.0														6.3	7.3			6.2	5.4	5.2
40.0															5.4			6.0	5.3	5.2
42.0																			5.2	5.1
44.0																			5.1	5.0
θ(°)	65~ 84.5	67~ 84.5	66~ 84.5	68~ 84.5	68~ 84.5	68~ 84.5	68~ 84.5	69~ 84.5	69~ 84.5	70~ 84.5	69~ 84.5	71~ 84.5	72~ 84.5	74~ 84.5	73~ 84.5	68~ 84.5	71~ 84.5	73~ 84.5	74~ 84.5	76~ 84.5
標準フック	35t					35t					12.2t									
フック重量	950kg					950kg					440kg									
標準巻掛本数	3					2					1									

PS+フルオートラフィングジブ

カウンタウエイト 58t、アウトリガ張出幅 6.8m
PS+50.5mブーム+2.3m+フルオートラフィングジブ

単位:t

ジブ長さ(m) 作業半径 (m)	10.3m オフセット					17.2m オフセット					24.1m オフセット					31.0m オフセット				
	5°	15°	30°	45°	60°	5°	15°	30°	45°	60°	5°	15°	30°	45°	60°	5°	15°	30°	45°	60°
11.0	21.0																			
12.0	21.0																			
14.0	21.0	20.4				15.9														
16.0	21.0	19.0	16.7	15.2		15.9	15.6				12.2									
18.0	19.7	17.8	15.7	14.4	13.6	15.9	14.5				12.2					9.0				
20.0	18.1	16.6	14.8	13.7	13.0	15.5	13.6	11.7			12.2	11.5				9.0				
22.0	13.6	15.1	14.0	13.0	12.4	14.5	12.8	11.1	10.0		12.2	10.9				9.0				
24.0	10.0	11.3	13.1	12.4	11.9	13.1	12.1	10.6	9.6	9.0	11.7	10.2				9.0	8.9			
26.0		8.2	9.7	10.8	11.4	10.0	11.4	10.0	9.2	8.6	10.9	9.7	8.4			9.0	8.7			
28.0			6.9	7.9	8.3	7.5	9.3	9.6	8.8	8.3	9.6	9.1	8.0			9.0	8.3			
30.0								9.1	8.4	8.0	7.4	8.7	7.6	6.9		8.8	7.8	6.8		
32.0								6.8	8.1	7.8		7.5	7.2	6.6	6.2	7.6	7.4	6.5		
34.0										6.9			6.9	6.4	5.9		7.1	6.2		
36.0												6.4	6.0	5.7		6.5	5.9	5.4		
38.0													5.7	5.4			5.6	5.1	4.7	
40.0																	5.3	4.8	4.4	
42.0																		4.5	4.2	
44.0																			4.0	
θ(°)	69~ 84.5	69~ 84.5	69~ 84.5	70~ 84.5	70~ 84.5	69~ 84.5	72~ 84.5	71~ 84.5	73~ 84.5	72~ 84.5	70~ 84.5	72~ 84.5	73~ 84.5	74~ 84.5	76~ 84.5	72~ 84.5	73~ 84.5	75~ 84.5	78~ 84.5	79~ 84.5
標準フック	35t										12.2t									
フック重量	950kg										440kg									
標準巻掛本数	2										1									

カウンタウエイト 58t、アウトリガ張出幅 6.8m
PS+55.6mブーム+2.3m+フルオートラフィングジブ

単位:t

ジブ長さ(m) 作業半径 (m)	10.3m オフセット					17.2m オフセット					24.1m オフセット					31.0m オフセット				
	5°	15°	30°	45°	60°	5°	15°	30°	45°	60°	5°	15°	30°	45°	60°	5°	15°	30°	45°	60°
12.0	15.0																			
14.0	15.0	15.0				11.7														
16.0	15.0	15.0	14.5			11.7														
18.0	15.0	15.0	13.5	12.6	11.9	11.7	11.7				8.8									
20.0	15.0	13.9	12.6	11.8	11.3	11.7	11.7				8.8					6.8				
22.0	14.0	13.0	11.9	11.1	10.7	11.7	10.9	9.7			8.8	8.8				6.8				
24.0	10.7	12.0	11.1	10.5	10.1	11.2	10.2	9.1	8.4		8.8	8.8				6.8				
26.0		8.9	10.4	9.9	9.5	10.2	9.6	8.6	8.0	7.6	8.8	8.7	7.7			6.8	6.8			
28.0				8.6	8.8		9.0	8.1	7.5	7.1	8.8	8.1	7.2			6.8	6.8			
30.0								7.5	6.9	6.6		7.7	6.8	6.3		6.8	6.8			
32.0									6.4	6.1		7.0	6.3	5.8	5.5		6.5	5.7		
34.0										5.7			5.8	5.4	5.1		5.9	5.3		
36.0														5.0	4.7			4.9	4.5	
38.0														4.6	4.4			4.5	4.2	
40.0																			3.9	3.7
42.0																			3.6	3.4
44.0																				3.1
θ(°)	71~ 84.5	71~ 84.5	73~ 84.5	72~ 84.5	73~ 84.5	72~ 84.5	74~ 84.5	75~ 84.5	75~ 84.5	75~ 84.5	74~ 84.5	74~ 84.5	77~ 84.5	77~ 84.5	79~ 84.5	76~ 84.5	76~ 84.5	78~ 84.5	79~ 84.5	81~ 84.5
標準フック	35t										12.2t									
フック重量	950kg										440kg									
標準巻掛本数	2										1									

カウンタウエイト 58t、アウトリガ張出幅 6.8m
PS+60.0mブーム+2.3m+フルオートラフィングジブ

単位:t

ジブ長さ(m) 作業半径 (m)	10.3m オフセット					17.2m オフセット					24.1m オフセット					31.0m オフセット				
	5°	15°	30°	45°	60°	5°	15°	30°	45°	60°	5°	15°	30°	45°	60°	5°	15°	30°	45°	60°
14.0	11.5																			
16.0	11.5	11.5				8.7														
18.0	11.5	11.5	11.5	11.5		8.7	8.7				6.8									
20.0	11.5	11.5	11.5	11.0	10.5	8.7	8.7				6.8					5.3				
22.0	11.5	11.5	11.0	10.4	9.9	8.7	8.7	8.7			6.8	6.8				5.3				
24.0		11.3	10.2	9.5	9.2	8.7	8.7	8.4			6.8	6.8				5.3				
26.0			9.3	8.7	8.4	8.7	8.7	7.6	7.0	6.6	6.8	6.8				5.3	5.3			
28.0					7.7		8.0	7.0	6.4	6.1	6.8	6.8	5.9			5.3	5.3			
30.0								6.4	5.9	5.6		6.2	5.4			5.3	5.3			
32.0									5.4	5.2			4.9	4.5			5.0			
34.0													4.5	4.1	3.9			4.0		
36.0														3.8	3.6			3.6		
38.0															3.3				3.0	
40.0																			2.8	
42.0																				2.4
θ(°)	75~ 84.5	75~ 84.5	75~ 84.5	76~ 84.5	75~ 84.5	75~ 84.5	75~ 84.5	77~ 84.5	77~ 84.5	78~ 84.5	76~ 84.5	77~ 84.5	78~ 84.5	80~ 84.5	80~ 84.5	77~ 84.5	79~ 84.5	81~ 84.5	82~ 84.5	84~ 84.5
標準フック	12.2t										12.2t									
フック重量	440kg										440kg									
標準巻掛本数	1										1									

カウンタウエイト 47t、アウトリガ張出幅 8.5m
PS+40.4mブーム+2.3m+フルオートラフingジブ

単位:t

ジブ長さ(m) 作業半径 (m)	10.3m オフセット					17.2m オフセット					24.1m オフセット					31.0m オフセット				
	5°	15°	30°	45°	60°	5°	15°	30°	45°	60°	5°	15°	30°	45°	60°	5°	15°	30°	45°	60°
9.0	37.6																			
10.0	37.6					16.7														
11.0	37.6	37.6				16.7	16.7													
12.0	37.6	37.6				16.7														
14.0	37.6	37.6	30.3	25.6		16.7	16.7				16.4									
16.0	33.3	35.0	29.0	24.8	22.8	16.7	16.7				16.0					10.9				
18.0	26.0	27.6	27.8	24.2	22.4	16.7	16.7	16.7			15.6	14.0				10.9				
20.0	20.3	21.8	23.7	23.5	22.1	16.7	16.7	16.7	14.9		15.2	13.6				10.7				
22.0	15.6	17.2	18.8	19.9	20.6	16.7	16.7	16.7	14.5	13.1	14.7	13.1	11.6			10.5	9.7			
24.0	11.6	13.0	14.7	15.8	16.2	15.3	16.7	16.3	14.1	12.9	14.2	12.7	11.3			10.3	9.3			
26.0	8.3	9.5	11.0	12.0	12.4	11.9	13.9	15.7	13.7	12.7	13.7	12.3	11.0	9.8		10.0	8.9			
28.0		6.6	7.9	8.7	8.9	9.1	10.8	13.1	13.4	12.5	11.6	12.0	10.6	9.6		9.8	8.5	7.2		
30.0				5.9		6.7	8.3	10.4	11.9	12.4	9.1	11.3	10.3	9.3	8.5	9.5	8.2	7.0		
32.0							6.1	7.9	9.3	10.0	7.1	9.0	10.1	9.1	8.4	9.1	7.9	6.7		
34.0								5.8	6.9	7.4	5.3	7.0	9.5	8.9	8.3	7.5	7.6	6.5	5.7	
36.0									4.9	5.2		5.3	7.5	8.8	8.2	5.9	7.4	6.3	5.6	5.3
38.0													5.8	7.3	8.1	4.5	6.4	6.1	5.4	5.2
40.0													4.2	5.6	6.2		4.9	5.9	5.3	5.1
42.0															4.4			5.8	5.2	5.1
44.0																		4.6	5.2	5.0
46.0																			4.8	5.0
θ (°)	62~ 84.5	61~ 84.5	63~ 84.5	62~ 84.5	64~ 84.5	63~ 84.5	63~ 84.5	64~ 84.5	64~ 84.5	65~ 84.5	62~ 84.5	64~ 84.5	64~ 84.5	67~ 84.5	66~ 84.5	62~ 84.5	65~ 84.5	67~ 84.5	69~ 84.5	72~ 84.5
標準フック	80t					35t					12.2t									
フック重量	1550kg					950kg					440kg									
標準巻掛本数	4					2					1									

PS+FLJ

カウンタウエイト 47t、アウトリガ張出幅 8.5m
PS+45.4mブーム+2.3m+フルオートラフingジブ

単位:t

ジブ長さ(m) 作業半径 (m)	10.3m オフセット					17.2m オフセット					24.1m オフセット					31.0m オフセット					
	5°	15°	30°	45°	60°	5°	15°	30°	45°	60°	5°	15°	30°	45°	60°	5°	15°	30°	45°	60°	
10.0	28.6																				
11.0	28.6																				
12.0	28.6	28.6				16.7															
14.0	28.6	28.6	28.6			16.7					15.5										
16.0	28.6	28.6	28.6	25.2	23.0	16.7	16.7				15.3										
18.0	26.2	27.9	28.1	24.6	22.7	16.7	16.7				14.9	13.9				10.5					
20.0	20.6	22.1	24.0	24.0	22.4	16.7	16.7	16.7			14.7	13.5				10.3					
22.0	15.9	17.4	19.1	20.3	21.0	16.7	16.7	16.7	14.6		14.4	13.1				10.1	9.5				
24.0	11.9	13.3	15.0	16.2	16.7	15.1	16.7	16.6	14.2	12.9	14.1	12.7	11.3			9.9	9.2				
26.0	8.6	9.8	11.4	12.4	12.9	11.8	13.8	16.1	13.9	12.7	13.7	12.3	11.0			9.7	8.9				
28.0		6.9	8.3	9.2	9.5	8.9	10.8	13.2	13.6	12.6	11.3	12.0	10.6	9.6		9.5	8.6				
30.0				6.4	6.6	6.6	8.2	10.4	12.0	12.5	8.9	11.1	10.4	9.4	8.6	9.3	8.2	7.0			
32.0							6.0	8.0	9.4	10.2	6.8	8.9	10.1	9.2	8.4	9.1	8.0	6.8			
34.0								5.8	7.1	7.7		6.9	9.4	9.0	8.3	7.2	7.7	6.6	5.7		
36.0										5.5			7.4	8.8	8.2	5.6	7.4	6.4	5.6		
38.0													5.7	7.4	8.1		6.1	6.2	5.4	5.2	
40.0														5.6	6.5			6.0	5.3	5.2	
42.0																		5.8	5.2	5.1	
44.0																			5.1	5.0	
46.0																				4.8	5.0
θ (°)	65~ 84.5	64~ 84.5	66~ 84.5	65~ 84.5	66~ 84.5	66~ 84.5	66~ 84.5	67~ 84.5	69~ 84.5	67~ 84.5	69~ 84.5	70~ 84.5	71~ 84.5	73~ 84.5	66~ 84.5	69~ 84.5	72~ 84.5	72~ 84.5	74~ 84.5		
標準フック	35t					35t					12.2t										
フック重量	950kg					950kg					440kg										
標準巻掛本数	3					2					1										

PS+フルオートラフィングジブ

カウンタウエイト 47t、アウトリガ張出幅 8.5m
PS+50.5mブーム+2.3m+フルオートラフィングジブ

単位:t

ジブ長さ(m) 作業半径 (m)	10.3m オフセット					17.2m オフセット					24.1m オフセット					31.0m オフセット				
	5°	15°	30°	45°	60°	5°	15°	30°	45°	60°	5°	15°	30°	45°	60°	5°	15°	30°	45°	60°
11.0	21.0																			
12.0	21.0																			
14.0	21.0	20.4				15.9														
16.0	21.0	19.0	16.7	15.2		15.9	15.6				12.2									
18.0	19.7	17.8	15.7	14.4	13.6	15.9	14.5				12.2					9.0				
20.0	18.4	16.6	14.8	13.7	13.0	15.5	13.6	11.7			12.2	11.5				9.0				
22.0	16.1	15.7	14.0	13.0	12.4	14.5	12.8	11.1	10.0		12.2	10.9				9.0				
24.0	12.0	13.5	13.3	12.4	11.9	13.5	12.1	10.6	9.6	9.0	11.7	10.2				9.0	8.9			
26.0	8.8	10.0	11.6	11.9	11.5	11.9	11.4	10.0	9.2	8.6	10.9	9.7	8.4			9.0	8.7			
28.0		7.2	8.5	9.5	9.9	9.1	10.8	9.6	8.8	8.3	10.3	9.1	8.0			9.0	8.3			
30.0				6.8	7.1		8.4	9.1	8.4	8.0	8.9	8.7	7.6	6.9		8.8	7.8	6.8		
32.0							8.2	8.1	7.8	6.8	8.2	7.2	6.6	6.2		8.4	7.4	6.5		
34.0								7.4	7.5		6.9	6.9	6.4	5.9		7.1	7.1	6.2		
36.0									6.0			6.6	6.0	5.7			6.7	5.9	5.4	
38.0													5.7	5.4		6.1	5.6	5.1	4.7	
40.0													5.4	5.1			5.3	4.8	4.4	
42.0																	5.0	4.5	4.2	
44.0																			4.3	4.0
46.0																				3.8
θ(°)	67~ 84.5	67~ 84.5	69~ 84.5	68~ 84.5	68~ 84.5	69~ 84.5	70~ 84.5	71~ 84.5	71~ 84.5	70~ 84.5	69~ 84.5	70~ 84.5	73~ 84.5	72~ 84.5	74~ 84.5	70~ 84.5	72~ 84.5	73~ 84.5	76~ 84.5	77~ 84.5
標準フック	35t										12.2t									
フック重量	950kg										440kg									
標準巻掛本数	2										1									

カウンタウエイト 47t、アウトリガ張出幅 8.5m
PS+55.6mブーム+2.3m+フルオートラフィングジブ

単位:t

ジブ長さ(m) 作業半径 (m)	10.3m オフセット					17.2m オフセット					24.1m オフセット					31.0m オフセット				
	5°	15°	30°	45°	60°	5°	15°	30°	45°	60°	5°	15°	30°	45°	60°	5°	15°	30°	45°	60°
12.0	15.0																			
14.0	15.0	15.0				11.7														
16.0	15.0	15.0	14.5			11.7														
18.0	15.0	15.0	13.5	12.6	11.9	11.7	11.7				8.8									
20.0	15.0	13.9	12.6	11.8	11.3	11.7	11.7				8.8					6.8				
22.0	14.0	13.0	11.9	11.1	10.7	11.7	10.9	9.7			8.8	8.8				6.8				
24.0	12.7	12.1	11.1	10.5	10.1	11.2	10.2	9.1	8.4		8.8	8.8				6.8				
26.0	9.4	10.7	10.5	9.9	9.5	10.5	9.6	8.6	8.0	7.6	8.8	8.7	7.7			6.8	6.8			
28.0			9.2	9.2	8.8	9.2	9.0	8.1	7.5	7.1	8.8	8.1	7.2			6.8	6.8			
30.0					7.9		8.2	7.5	6.9	6.6	8.4	7.7	6.8	6.3		6.8	6.8			
32.0								6.9	6.4	6.1		7.0	6.3	5.8	5.5	6.8	6.5	5.7		
34.0									6.0	5.7		6.5	5.8	5.4	5.1		5.9	5.3		
36.0													5.4	5.0	4.7		5.5	4.9	4.5	
38.0														4.6	4.4			4.5	4.2	
40.0															4.1				3.9	3.7
42.0																			3.6	3.4
44.0																			3.3	3.1
θ(°)	70~ 84.5	71~ 84.5	71~ 84.5	72~ 84.5	71~ 84.5	71~ 84.5	72~ 84.5	73~ 84.5	73~ 84.5	75~ 84.5	73~ 84.5	73~ 84.5	75~ 84.5	77~ 84.5	77~ 84.5	74~ 84.5	75~ 84.5	77~ 84.5	78~ 84.5	81~ 84.5
標準フック	35t										12.2t									
フック重量	950kg										440kg									
標準巻掛本数	2										1									

カウンタウエイト 47t、アウトリガ張出幅 8.5m
PS+60.0mブーム+2.3m+フルオートラフィングジブ

単位:t

ジブ長さ(m) 作業半径 (m)	10.3m オフセット					17.2m オフセット					24.1m オフセット					31.0m オフセット				
	5°	15°	30°	45°	60°	5°	15°	30°	45°	60°	5°	15°	30°	45°	60°	5°	15°	30°	45°	60°
14.0	11.5																			
16.0	11.5	11.5				8.7														
18.0	11.5	11.5	11.5	11.5		8.7	8.7				6.8									
20.0	11.5	11.5	11.5	11.0	10.5	8.7	8.7				6.8					5.3				
22.0	11.5	11.5	11.0	10.4	9.9	8.7	8.7	8.7			6.8	6.8				5.3				
24.0	11.5	11.3	10.2	9.5	9.2	8.7	8.7	8.4			6.8	6.8				5.3				
26.0		10.4	9.3	8.7	8.4	8.7	8.7	7.6	7.0	6.6	6.8	6.8				5.3	5.3			
28.0				7.9	7.7	8.7	8.0	7.0	6.4	6.1	6.8	6.8	5.9			5.3	5.3			
30.0							7.2	6.4	5.9	5.6	6.8	6.2	5.4			5.3	5.3			
32.0								5.8	5.4	5.2		5.6	4.9	4.5			5.0			
34.0									4.9	4.8			4.5	4.1	3.9		4.5	4.0		
36.0													4.1	3.8	3.6			3.6		
38.0														3.5	3.3			3.3	3.0	
40.0															3.0				2.8	
42.0																			2.5	2.4
44.0																				2.2
θ(°)	73~ 84.5	73~ 84.5	75~ 84.5	74~ 84.5	75~ 84.5	74~ 84.5	74~ 84.5	75~ 84.5	75~ 84.5	77~ 84.5	74~ 84.5	75~ 84.5	77~ 84.5	78~ 84.5	78~ 84.5	77~ 84.5	78~ 84.5	80~ 84.5	81~ 84.5	82~ 84.5
標準フック	35t										12.2t									
フック重量	950kg										440kg									
標準巻掛本数	2										1									

カウンタウエイト 47t、アウトリガ張出幅 8.0m
PS+40.4mブーム+2.3m+フルオートラフィングジブ

単位:t

ジブ長さ(m) 作業半径 (m)	10.3m オフセット					17.2m オフセット					24.1m オフセット					31.0m オフセット				
	5°	15°	30°	45°	60°	5°	15°	30°	45°	60°	5°	15°	30°	45°	60°	5°	15°	30°	45°	60°
9.0	37.6																			
10.0	37.6					16.7														
11.0	37.6	37.6				16.7														
12.0	37.6	37.6				16.7														
14.0	37.6	37.6	30.3	25.6		16.7	16.7				16.4									
16.0	30.8	32.8	29.0	24.8	22.8	16.7	16.7				16.0					10.9				
18.0	23.7	25.4	27.6	24.2	22.4	16.7	16.7	16.7			15.6	14.0				10.9				
20.0	18.3	19.8	21.6	23.0	22.1	16.7	16.7	16.7	14.9		15.2	13.6				10.7				
22.0	13.7	15.2	17.0	18.2	18.8	16.7	16.7	16.7	14.5	13.1	14.7	13.1	11.6			10.5	9.7			
24.0	9.9	11.2	12.9	14.1	14.7	13.5	15.5	16.3	14.1	12.9	14.2	12.7	11.3			10.3	9.3			
26.0	6.8	8.0	9.5	10.4	10.8	10.3	12.3	14.6	13.7	12.7	12.9	12.3	11.0	9.8		10.0	8.9			
28.0			6.5	7.3	7.5	7.7	9.4	11.8	13.3	12.5	10.2	12.0	10.6	9.6		9.8	8.5	7.2		
30.0						5.4	7.0	9.1	10.6	11.5	7.9	10.0	10.3	9.3	8.5	9.5	8.2	7.0		
32.0								6.7	8.1	8.8	5.9	7.8	10.1	9.1	8.4	8.2	7.9	6.7		
34.0										5.8	6.3		5.9	8.4	8.9	8.3	6.4	7.6	6.5	5.7
36.0													6.5	8.2	8.2	4.9	6.9	6.3	5.6	5.3
38.0													4.8	6.3	7.2		5.4	6.1	5.4	5.2
40.0														4.6	5.3			5.9	5.3	5.1
42.0																		5.0	5.2	5.1
44.0																			5.2	5.0
46.0																				4.9
θ (°)	62~ 84.5	64~ 84.5	63~ 84.5	64~ 84.5	64~ 84.5	63~ 84.5	66~ 84.5	67~ 84.5	67~ 84.5	68~ 84.5	64~ 84.5	66~ 84.5	66~ 84.5	67~ 84.5	69~ 84.5	64~ 84.5	67~ 84.5	69~ 84.5	71~ 84.5	72~ 84.5
標準フック	80t					35t					12.2t									
フック重量	1550kg					950kg					440kg									
標準巻掛本数	4					2					1									

PS+FLJ

カウンタウエイト 47t、アウトリガ張出幅 8.0m
PS+45.4mブーム+2.3m+フルオートラフィングジブ

単位:t

ジブ長さ(m) 作業半径 (m)	10.3m オフセット					17.2m オフセット					24.1m オフセット					31.0m オフセット				
	5°	15°	30°	45°	60°	5°	15°	30°	45°	60°	5°	15°	30°	45°	60°	5°	15°	30°	45°	60°
10.0	28.6																			
11.0	28.6																			
12.0	28.6	28.6				16.7														
14.0	28.6	28.6	28.6			16.7					15.5									
16.0	28.6	28.6	28.6	25.2	23.0	16.7	16.7				15.3									
18.0	23.9	25.6	27.9	24.6	22.7	16.7	16.7				14.9	13.9				10.5				
20.0	18.6	20.0	21.9	23.4	22.4	16.7	16.7	16.7			14.7	13.5				10.3				
22.0	13.9	15.5	17.3	18.5	19.2	16.7	16.7	16.7	14.6		14.4	13.1				10.1	9.5			
24.0	10.1	11.5	13.3	14.6	15.1	13.4	15.5	16.6	14.2	12.9	14.1	12.7	11.3			9.9	9.2			
26.0	7.1	8.3	9.8	10.9	11.3	10.2	12.2	14.6	13.9	12.7	12.6	12.3	11.0			9.7	8.9			
28.0			6.9	7.8	8.1	7.6	9.4	11.8	13.4	12.6	9.9	12.0	10.6	9.6		9.5	8.6			
30.0							6.9	9.1	10.8	11.7	7.6	9.8	10.4	9.4	8.6	9.3	8.2	7.0		
32.0								6.8	8.2	9.0		7.7	10.1	9.2	8.4	7.9	8.0	6.8		
34.0									6.0	6.6			8.3	9.0	8.3	6.1	7.7	6.6	5.7	
36.0													6.4	8.3	8.2		6.7	6.4	5.6	
38.0														6.4	7.4			6.2	5.4	5.2
40.0															5.5			6.0	5.3	5.2
42.0																			5.2	5.1
44.0																			5.1	5.0
θ (°)	65~ 84.5	67~ 84.5	66~ 84.5	68~ 84.5	68~ 84.5	68~ 84.5	68~ 84.5	69~ 84.5	69~ 84.5	70~ 84.5	69~ 84.5	71~ 84.5	72~ 84.5	74~ 84.5	73~ 84.5	68~ 84.5	71~ 84.5	73~ 84.5	74~ 84.5	76~ 84.5
標準フック	35t					35t					12.2t									
フック重量	950kg					950kg					440kg									
標準巻掛本数	3					2					1									

PS+フルオートラフィングジブ

カウンタウエイト 47t、アウトリガ張出幅 8.0m
PS+50.5mブーム+2.3m+フルオートラフィングジブ

単位:t

ジブ長さ(m) 作業半径 (m)	10.3m オフセット					17.2m オフセット					24.1m オフセット					31.0m オフセット				
	5°	15°	30°	45°	60°	5°	15°	30°	45°	60°	5°	15°	30°	45°	60°	5°	15°	30°	45°	60°
11.0	21.0																			
12.0	21.0																			
14.0	21.0	20.4				15.9														
16.0	21.0	19.0	16.7	15.2		15.9	15.6				12.2									
18.0	19.7	17.8	15.7	14.4	13.6	15.9	14.5				12.2					9.0				
20.0	18.4	16.6	14.8	13.7	13.0	15.5	13.6	11.7			12.2	11.5				9.0				
22.0	14.1	15.7	14.0	13.0	12.4	14.5	12.8	11.1	10.0		12.2	10.9				9.0				
24.0	10.3	11.7	13.3	12.4	11.9	13.5	12.1	10.6	9.6	9.0	11.7	10.2				9.0	8.9			
26.0		8.5	10.1	11.2	11.5	10.4	11.4	10.0	9.2	8.6	10.9	9.7	8.4			9.0	8.7			
28.0			7.2	8.1	8.5	7.7	9.5	9.6	8.8	8.3	9.9	9.1	8.0			9.0	8.3			
30.0								9.1	8.4	8.0	7.6	8.7	7.6	6.9		8.8	7.8	6.8		
32.0								7.0	8.1	7.8		7.7	7.2	6.6	6.2	7.8	7.4	6.5		
34.0										7.1			6.9	6.4	5.9	7.1	6.2			
36.0													6.5	6.0	5.7	6.7	5.9	5.4		
38.0														5.7	5.4			5.6	5.1	4.7
40.0																		5.3	4.8	4.4
42.0																			4.5	4.2
44.0																				4.0
θ(°)	69~ 84.5	69~ 84.5	69~ 84.5	70~ 84.5	70~ 84.5	69~ 84.5	72~ 84.5	71~ 84.5	73~ 84.5	72~ 84.5	70~ 84.5	72~ 84.5	73~ 84.5	74~ 84.5	76~ 84.5	72~ 84.5	73~ 84.5	75~ 84.5	78~ 84.5	79~ 84.5
標準フック	35t										12.2t									
フック重量	950kg										440kg									
標準巻掛本数	2										1									

カウンタウエイト 47t、アウトリガ張出幅 8.0m
PS+55.6mブーム+2.3m+フルオートラフィングジブ

単位:t

ジブ長さ(m) 作業半径 (m)	10.3m オフセット					17.2m オフセット					24.1m オフセット					31.0m オフセット				
	5°	15°	30°	45°	60°	5°	15°	30°	45°	60°	5°	15°	30°	45°	60°	5°	15°	30°	45°	60°
12.0	15.0																			
14.0	15.0	15.0				11.7														
16.0	15.0	15.0	14.5			11.7														
18.0	15.0	15.0	13.5	12.6	11.9	11.7	11.7				8.8									
20.0	15.0	13.9	12.6	11.8	11.3	11.7	11.7				8.8					6.8				
22.0	14.0	13.0	11.9	11.1	10.7	11.7	10.9	9.7			8.8	8.8				6.8				
24.0	11.0	12.1	11.1	10.5	10.1	11.2	10.2	9.1	8.4		8.8	8.8				6.8				
26.0		9.2	10.5	9.9	9.5	10.5	9.6	8.6	8.0	7.6	8.8	8.7	7.7			6.8	6.8			
28.0				8.8	8.8		9.0	8.1	7.5	7.1	8.8	8.1	7.2			6.8	6.8			
30.0								7.5	6.9	6.6		7.7	6.8	6.3		6.8	6.8			
32.0									6.4	6.1		7.0	6.3	5.8	5.5		6.5	5.7		
34.0										5.7			5.8	5.4	5.1		5.9	5.3		
36.0														5.0	4.7			4.9	4.5	
38.0														4.6	4.4			4.5	4.2	
40.0																			3.9	3.7
42.0																			3.6	3.4
44.0																				3.1
θ(°)	71~ 84.5	71~ 84.5	73~ 84.5	72~ 84.5	73~ 84.5	72~ 84.5	74~ 84.5	75~ 84.5	75~ 84.5	75~ 84.5	74~ 84.5	74~ 84.5	77~ 84.5	77~ 84.5	79~ 84.5	76~ 84.5	76~ 84.5	78~ 84.5	79~ 84.5	81~ 84.5
標準フック	35t										12.2t									
フック重量	950kg										440kg									
標準巻掛本数	2										1									

カウンタウエイト 47t、アウトリガ張出幅 8.0m
PS+60.0mブーム+2.3m+フルオートラフィングジブ

単位:t

ジブ長さ(m) 作業半径 (m)	10.3m オフセット					17.2m オフセット					24.1m オフセット					31.0m オフセット				
	5°	15°	30°	45°	60°	5°	15°	30°	45°	60°	5°	15°	30°	45°	60°	5°	15°	30°	45°	60°
14.0	11.5																			
16.0	11.5	11.5				8.7														
18.0	11.5	11.5	11.5	11.5		8.7	8.7				6.8									
20.0	11.5	11.5	11.5	11.0	10.5	8.7	8.7				6.8					5.3				
22.0	11.5	11.5	11.0	10.4	9.9	8.7	8.7	8.7			6.8	6.8				5.3				
24.0		11.3	10.2	9.5	9.2	8.7	8.7	8.4			6.8	6.8				5.3				
26.0			9.3	8.7	8.4	8.7	8.7	7.6	7.0	6.6	6.8	6.8				5.3	5.3			
28.0					7.7		8.0	7.0	6.4	6.1	6.8	6.8	5.9			5.3	5.3			
30.0								6.4	5.9	5.6		6.2	5.4			5.3	5.3			
32.0									5.4	5.2					4.9	4.5				
34.0															4.5	4.1	3.9			
36.0																3.8	3.6			
38.0																	3.3			
40.0																				3.0
42.0																				2.8
44.0																				2.4
θ(°)	75~ 84.5	75~ 84.5	75~ 84.5	76~ 84.5	75~ 84.5	75~ 84.5	75~ 84.5	77~ 84.5	77~ 84.5	78~ 84.5	76~ 84.5	77~ 84.5	78~ 84.5	80~ 84.5	80~ 84.5	77~ 84.5	79~ 84.5	81~ 84.5	82~ 84.5	84~ 84.5
標準フック	12.2t										12.2t									
フック重量	440kg										440kg									
標準巻掛本数	1										1									

カウンタウエイト 47t、アウトリガ張出幅 6.8m
PS+40.4mブーム+2.3m+フルオートラフィングジブ

単位:t

ジブ長さ(m) 作業半径 (m)	10.3m オフセット					17.2m オフセット					24.1m オフセット					31.0m オフセット				
	5°	15°	30°	45°	60°	5°	15°	30°	45°	60°	5°	15°	30°	45°	60°	5°	15°	30°	45°	60°
9.0	37.6																			
10.0	37.6					16.7														
11.0	37.6	37.6				16.7														
12.0	37.6	37.6				16.7														
14.0	32.3	34.7	30.3	25.6		16.7	16.7				16.4									
16.0	24.2	26.1	28.6	24.8	22.8	16.7	16.7				16.0					10.9				
18.0	18.2	19.9	22.0	23.6	22.4	16.7	16.7	16.7			15.6	14.0				10.9				
20.0	13.2	14.9	16.9	18.3	19.1	16.7	16.7	16.7	14.9		15.2	13.6				10.7				
22.0	9.2	10.7	12.6	14.0	14.7	12.8	15.1	16.7	14.5	13.1	14.7	13.1	11.6			10.5	9.7			
24.0			8.9	10.1	10.6	9.5	11.6	14.2	14.1	12.9	12.0	12.7	11.3			10.3	9.3			
26.0					7.2	6.7	8.6	11.2	13.0	12.7	9.2	11.8	11.0	9.8		10.0	8.9			
28.0								8.4	10.2	11.2	6.9	9.2	10.6	9.6		9.2	8.5	7.2		
30.0								6.0	7.6	8.4		7.0	9.9	9.3	8.5	7.2	8.2	7.0		
32.0										5.9			7.7	9.1	8.4		7.8	6.7		
34.0													5.7	7.7	8.3		6.0	6.5	5.7	
36.0														5.8	6.9			6.3	5.6	5.3
38.0																		5.7	5.4	5.2
40.0																			5.3	5.1
42.0																				5.1
θ(°)	67~ 84.5	69~ 84.5	69~ 84.5	70~ 84.5	68~ 84.5	68~ 84.5	70~ 84.5	69~ 84.5	72~ 84.5	70~ 84.5	68~ 84.5	70~ 84.5	71~ 84.5	72~ 84.5	74~ 84.5	70~ 84.5	71~ 84.5	73~ 84.5	76~ 84.5	77~ 84.5
標準フック	80t					35t					12.2t									
フック重量	1550kg					950kg					440kg									
標準巻掛本数	4					2					1									

PS+FLJ

カウンタウエイト 47t、アウトリガ張出幅 6.8m
PS+45.4mブーム+2.3m+フルオートラフィングジブ

単位:t

ジブ長さ(m) 作業半径 (m)	10.3m オフセット					17.2m オフセット					24.1m オフセット					31.0m オフセット				
	5°	15°	30°	45°	60°	5°	15°	30°	45°	60°	5°	15°	30°	45°	60°	5°	15°	30°	45°	60°
10.0	28.6																			
11.0	28.6																			
12.0	28.6	28.6				16.7														
14.0	28.6	28.6	28.6			16.7					15.5									
16.0	24.4	26.4	28.6	25.2	23.0	16.7	16.7				15.3									
18.0	18.5	20.1	22.3	24.0	22.7	16.7	16.7				14.9	13.9				10.5				
20.0	13.5	15.2	17.2	18.6	19.4	16.7	16.7	16.7			14.7	13.5				10.3				
22.0	9.4	11.0	12.9	14.4	15.1	12.7	15.0	16.7	14.6		14.4	13.1				10.1	9.5			
24.0			9.3	10.5	11.1	9.4	11.6	14.2	14.2	12.9	11.8	12.7	11.3			9.9	9.2			
26.0					7.7		8.6	11.2	13.1	12.7	9.0	11.6	11.0			9.7	8.9			
28.0								8.4	10.3	11.4		9.0	10.6	9.6		8.9	8.6			
30.0									7.7	8.7			9.8	9.4	8.6		8.2	7.0		
32.0													7.6	9.2	8.4		7.5	6.8		
34.0														7.7	8.3			6.6	5.7	
36.0															7.0			6.4	5.6	
38.0																			5.4	5.2
40.0																			5.3	5.2
42.0																				5.1
θ(°)	70~ 84.5	71~ 84.5	71~ 84.5	73~ 84.5	71~ 84.5	72~ 84.5	72~ 84.5	73~ 84.5	74~ 84.5	75~ 84.5	72~ 84.5	75~ 84.5	76~ 84.5	78~ 84.5	78~ 84.5	73~ 84.5	74~ 84.5	77~ 84.5	78~ 84.5	79~ 84.5
標準フック	35t					35t					12.2t									
フック重量	950kg					950kg					440kg									
標準巻掛本数	3					2					1									

PS+フルオートラフィングジブ

カウンタウエイト 47t、アウトリガ張出幅 6.8m
PS+50.5mブーム+2.3m+フルオートラフィングジブ

単位:t

ジブ長さ(m) 作業半径 (m)	10.3m オフセット					17.2m オフセット					24.1m オフセット					31.0m オフセット				
	5°	15°	30°	45°	60°	5°	15°	30°	45°	60°	5°	15°	30°	45°	60°	5°	15°	30°	45°	60°
11.0	21.0																			
12.0	21.0																			
14.0	21.0	20.4				15.9														
16.0	21.0	19.0	16.7	15.2		15.9	15.6				12.2									
18.0	18.6	17.8	15.7	14.4	13.6	15.9	14.5				12.2					9.0				
20.0	13.6	15.4	14.8	13.7	13.0	15.5	13.6	11.7			12.2	11.5				9.0				
22.0		11.2	13.1	13.0	12.4	12.8	12.8	11.1	10.0		12.2	10.9				9.0				
24.0			9.5	10.8	11.5	9.5	11.7	10.6	9.6	9.0	11.7	10.2				9.0	8.9			
26.0					8.1			10.0	9.2	8.6		9.7	8.4			9.0	8.7			
28.0								8.6	8.8	8.3		9.0	8.0			8.8	8.3			
30.0									8.0	8.0			7.6	6.9			7.8	6.8		
32.0													7.2	6.6	6.2			6.5		
34.0														6.4	5.9			6.2		
36.0															5.7			5.9	5.4	
38.0																		5.1	4.7	
40.0																			4.4	
θ (°)	73~ 84.5	73~ 84.5	73~ 84.5	74~ 84.5	73~ 84.5	72~ 84.5	75~ 84.5	75~ 84.5	75~ 84.5	77~ 84.5	75~ 84.5	76~ 84.5	76~ 84.5	78~ 84.5	78~ 84.5	74~ 84.5	78~ 84.5	78~ 84.5	81~ 84.5	82~ 84.5
標準フック	35t										12.2t									
フック重量	950kg										440kg									
標準巻掛本数	2										1									

カウンタウエイト 47t、アウトリガ張出幅 6.8m
PS+55.6mブーム+2.3m+フルオートラフィングジブ

単位:t

ジブ長さ(m) 作業半径 (m)	10.3m オフセット					17.2m オフセット					24.1m オフセット					31.0m オフセット				
	5°	15°	30°	45°	60°	5°	15°	30°	45°	60°	5°	15°	30°	45°	60°	5°	15°	30°	45°	60°
12.0	15.0																			
14.0	15.0	15.0				11.7														
16.0	15.0	15.0	14.5			11.7														
18.0	15.0	15.0	13.5	12.6	11.9	11.7	11.7				8.8									
20.0	14.3	13.9	12.6	11.8	11.3	11.7	11.7				8.8					6.8				
22.0		11.8	11.9	11.1	10.7	11.7	10.9	9.7			8.8	8.8				6.8				
24.0				10.5	10.1		10.2	9.1	8.4		8.8	8.8				6.8				
26.0								8.6	8.0	7.6		8.7	7.7			6.8	6.8			
28.0									7.5	7.1		8.1	7.2			6.8				
30.0										6.6			6.8	6.3		6.8				
32.0														5.8	5.5			5.7		
34.0														5.4	5.1			5.3		
36.0															4.7				4.5	
38.0																			4.2	
40.0																				3.7
θ (°)	75~ 84.5	75~ 84.5	77~ 84.5	76~ 84.5	77~ 84.5	76~ 84.5	77~ 84.5	78~ 84.5	79~ 84.5	78~ 84.5	77~ 84.5	77~ 84.5	80~ 84.5	80~ 84.5	80~ 84.5	78~ 84.5	79~ 84.5	81~ 84.5	82~ 84.5	84~ 84.5
標準フック	35t										12.2t									
フック重量	950kg										440kg									
標準巻掛本数	2										1									

カウンタウエイト 47t、アウトリガ張出幅 6.8m
PS+60.0mブーム+2.3m+フルオートラフィングジブ

単位:t

ジブ長さ(m) 作業半径 (m)	10.3m オフセット					17.2m オフセット					24.1m オフセット					31.0m オフセット		
	5°	15°	30°	45°	60°	5°	15°	30°	45°	60°	5°	15°	30°	45°	60°	5°	15°	
14.0	11.5																	
16.0	11.5	11.5				8.7												
18.0	11.5	11.5	11.5	11.5		8.7	8.7				6.8							
20.0	11.5	11.5	11.5	11.0	10.5	8.7	8.7				6.8					5.3		
22.0			11.0	10.4	9.9	8.7	8.7	8.7			6.8	6.8				5.3		
24.0					9.2		8.7	8.4			6.8	6.8				5.3		
26.0								7.6	7.0	6.6		6.8				5.3		
28.0									6.4	6.1				5.9		5.3		
30.0										5.6				5.4				
32.0																		
34.0																4.5		
θ (°)	77~ 84.5	78~ 84.5	78~ 84.5	80~ 84.5	78~ 84.5	78~ 84.5	80~ 84.5	80~ 84.5	80~ 84.5	80~ 84.5	79~ 84.5	80~ 84.5	81~ 84.5	83~ 84.5	84~ 84.5	81~ 84.5	82~ 84.5	
標準フック	12.2t										12.2t							
フック重量	440kg										440kg							
標準巻掛本数	1										1							

カウンタウエイト 25t、アウトリガ張出幅 8.5m
PS+40.4mブーム+2.3m+フルオートラフィングジブ

単位:t

ジブ長さ(m) 作業半径 (m)	10.3m オフセット					17.2m オフセット					24.1m オフセット					31.0m オフセット				
	5°	15°	30°	45°	60°	5°	15°	30°	45°	60°	5°	15°	30°	45°	60°	5°	15°	30°	45°	60°
9.0	37.6																			
10.0	37.6					16.7														
11.0	37.6	37.6				16.7														
12.0	37.6	37.6				16.7														
14.0	29.8	32.4	30.3	25.6		16.7	16.7				16.4									
16.0	21.5	23.6	26.3	24.8	22.8	16.7	16.7				16.0					10.9				
18.0	15.5	17.3	19.6	21.3	22.4	16.7	16.7	16.7			15.6	14.0				10.9				
20.0		12.3	14.5	16.0	16.8	14.4	16.7	16.7			15.2	13.6				10.7				
22.0			10.1	11.6	12.4	10.4	12.9	15.6	14.5	13.1	13.0	13.1	11.6			10.5	9.7			
24.0							9.4	12.2	14.1	12.9	9.8	12.5	11.3			10.3	9.3			
26.0								9.2	11.1	12.2		9.7	11.0	9.8		9.6	8.9			
28.0									8.3	9.4			10.3	9.6		8.5	7.2			
30.0													8.1	9.3	8.5		7.9	7.0		
32.0														8.2	8.4			6.7		
34.0															7.4			6.5	5.7	
36.0																			5.6	5.3
38.0																			5.4	5.2
40.0																				5.1
θ(°)	72~ 84.5	71~ 84.5	71~ 84.5	73~ 84.5	73~ 84.5	72~ 84.5	72~ 84.5	74~ 84.5	74~ 84.5	76~ 84.5	72~ 84.5	74~ 84.5	75~ 84.5	77~ 84.5	77~ 84.5	73~ 84.5	74~ 84.5	77~ 84.5	78~ 84.5	79~ 84.5
標準フック											35t					12.2t				
フック重量	1550kg										950kg					440kg				
標準巻掛本数	4										2					1				

PS+FLJ

カウンタウエイト 25t、アウトリガ張出幅 8.5m
PS+45.4mブーム+2.3m+フルオートラフィングジブ

単位:t

ジブ長さ(m) 作業半径 (m)	10.3m オフセット					17.2m オフセット					24.1m オフセット					31.0m オフセット				
	5°	15°	30°	45°	60°	5°	15°	30°	45°	60°	5°	15°	30°	45°	60°	5°	15°	30°	45°	60°
10.0	28.6																			
11.0	28.6																			
12.0	28.6	28.6				16.7														
14.0	28.6	28.6	28.6			16.7					15.5									
16.0	21.8	23.8	26.6	25.2	23.0	16.7	16.7				15.3									
18.0	15.7	17.6	19.9	21.7	22.7	16.7	16.7				14.9	13.9				10.5				
20.0		12.6	14.8	16.3	17.2	14.3	16.7	16.7			14.7	13.5				10.3				
22.0			10.5	12.0	12.9		12.8	15.7	14.6		12.8	13.1				10.1	9.5			
24.0								12.2	14.2	12.9		12.3	11.3			9.9	9.2			
26.0								9.2	11.2	12.4		9.5	11.0				8.9			
28.0									8.4	9.6			10.3	9.6			8.6			
30.0														9.4	8.6			7.0		
32.0														8.2	8.4			6.8		
34.0																			5.7	
36.0																			5.6	
38.0																				5.2
θ(°)	74~ 84.5	73~ 84.5	73~ 84.5	75~ 84.5	76~ 84.5	76~ 84.5	76~ 84.5	76~ 84.5	76~ 84.5	77~ 84.5	76~ 84.5	76~ 84.5	80~ 84.5	80~ 84.5	82~ 84.5	76~ 84.5	78~ 84.5	80~ 84.5	81~ 84.5	83~ 84.5
標準フック											35t					12.2t				
フック重量	950kg										950kg					440kg				
標準巻掛本数	3										2					1				

PS+フルオートラフィングジブ

カウンタウエイト 25t、アウトリガ張出幅 8.5m
PS+50.5mブーム+2.3m+フルオートラフィングジブ

単位:t

ジブ長さ(m) 作業半径 (m)	10.3m オフセット					17.2m オフセット					24.1m オフセット					31.0m オフセット				
	5°	15°	30°	45°	60°	5°	15°	30°	45°	60°	5°	15°	30°	45°	60°	5°	15°	30°	45°	60°
11.0	21.0																			
12.0	21.0																			
14.0	21.0	20.4				15.9														
16.0	21.0	19.0	16.7	15.2		15.9	15.6				12.2									
18.0	15.9	17.7	15.7	14.4	13.6	15.9	14.5				12.2					9.0				
20.0		12.7	14.8	13.7	13.0	14.4	13.6	11.7			12.2	11.5				9.0				
22.0				12.3	12.4		12.8	11.1	10.0		12.2	10.9				9.0				
24.0								10.6	9.6	9.0		10.2				9.0	8.9			
26.0									9.2	8.6				8.4			8.7			
28.0										8.3				8.0			8.3			
30.0															6.9					6.8
32.0																6.2				6.5
34.0																				
36.0																				5.4
38.0																				4.7
θ (°)	75~ 84.5	75~ 84.5	77~ 84.5	76~ 84.5	77~ 84.5	76~ 84.5	77~ 84.5	78~ 84.5	79~ 84.5	79~ 84.5	77~ 84.5	79~ 84.5	80~ 84.5	82~ 84.5	82~ 84.5	77~ 84.5	79~ 84.5	81~ 84.5	83~ 84.5	84~ 84.5
標準フック	35t										12.2t									
フック重量	950kg										440kg									
標準巻掛本数	2										1									

カウンタウエイト 25t、アウトリガ張出幅 8.5m
PS+55.6mブーム+2.3m+フルオートラフィングジブ

単位:t

ジブ長さ(m) 作業半径 (m)	10.3m オフセット				17.2m オフセット					24.1m オフセット					31.0m オフセット		
	5°	15°	30°	45°	5°	15°	30°	45°	60°	5°	15°	30°	45°	60°	5°	15°	
12.0	15.0																
14.0	15.0	15.0				11.7											
16.0	15.0	15.0	14.5			11.7											
18.0	15.0	15.0	13.5	12.6	11.9	11.7	11.7				8.8						
20.0			12.6	11.8	11.3	11.7	11.7				8.8				6.8		
22.0				11.1	10.7		10.9	9.7			8.8	8.8			6.8		
24.0								9.1	8.4		8.8						
26.0									8.0	7.6			7.7			6.8	
28.0										7.1			7.2				
30.0														6.3			
32.0															5.5		
θ (°)	77~ 84.5	78~ 84.5	78~ 84.5	78~ 84.5	79~ 84.5	77~ 84.5	78~ 84.5	80~ 84.5	81~ 84.5	80~ 84.5	79~ 84.5	80~ 84.5	82~ 84.5	83~ 84.5	84~ 84.5	81~ 84.5	82~ 84.5
標準フック	35t										12.2t						
フック重量	950kg										440kg						
標準巻掛本数	2										1						

カウンタウエイト 25t、アウトリガ張出幅 8.5m
PS+60.0mブーム+2.3m+フルオートラフィングジブ

単位:t

ジブ長さ(m) 作業半径 (m)	10.3m オフセット					17.2m オフセット					24.1m オフセット		31.0m オフセット
	5°	15°	30°	45°	60°	5°	15°	30°	45°	60°	5°	15°	5°
14.0	11.5												
16.0	11.5	11.5				8.7							
18.0		11.5	11.5	11.5		8.7	8.7				6.8		
20.0			11.5	11.0	10.5		8.7				6.8		5.3
22.0								8.7				6.8	5.3
24.0									8.4				
26.0										7.0	6.6		
θ (°)	80~ 84.5	80~ 84.5	80~ 84.5	81~ 84.5	82~ 84.5	81~ 84.5	82~ 84.5	81~ 84.5	82~ 84.5	84~ 84.5	81~ 84.5	82~ 84.5	82~ 84.5
標準フック	12.2t												
フック重量	440kg												
標準巻掛本数	1												

フィックスジブ

■ フィックスジブ(LFJ)の構成

記号	名称	長さ
⑥	ミドルCジブ	6.0 m
⑦	ミドルDジブ	12.0 m
⑧	トップジブ	6.0 m

6.0mジブ

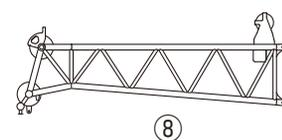

12.0mジブ

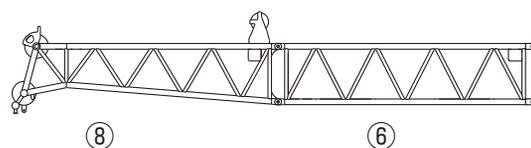

18.0mジブ

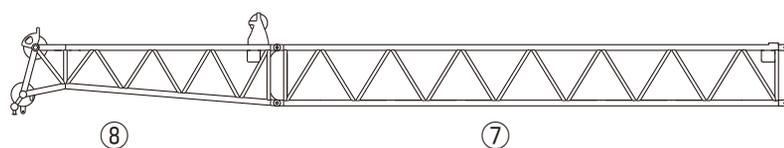

24.0mジブ

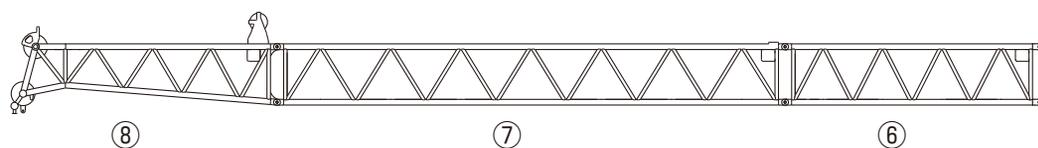

ブーム+フィックスジブ(LFJ)作業半径-揚程図

ブーム+フィックスジブ

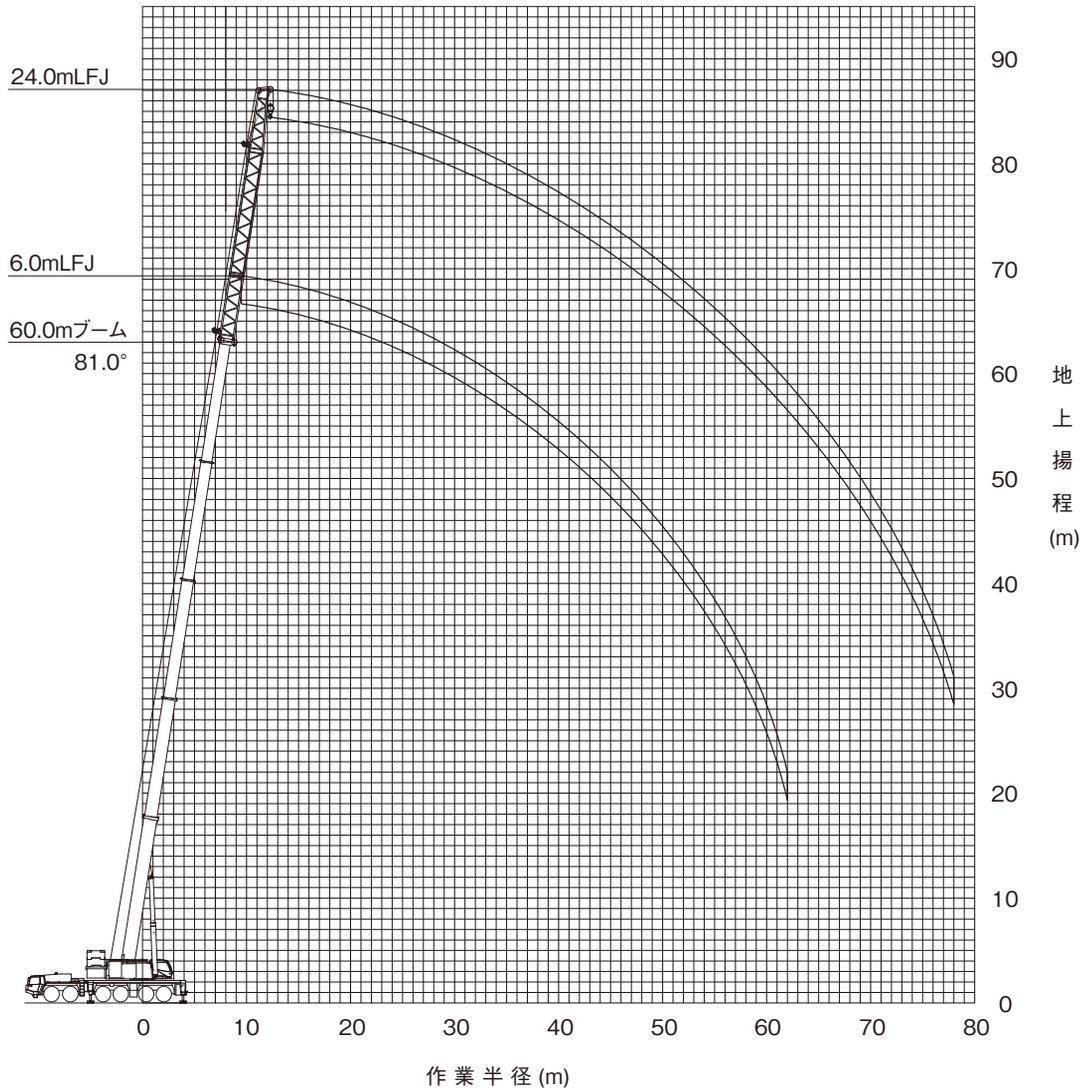

(注意)

- ◆ 上図はブームおよびジブのたわみを含んでいません。
- ◆ カウンタウエイト98t、アウトリガ張出幅8.5mの性能を図示しています。

LFJ

フィックスジブ

ブーム+フィックスジブ(LFJ)定格総荷重表

■ 定格総荷重表注意事項

◆性能設定のあるカウンタウエイトとアウトリガ張出幅の組合せを、下表に○印で示します。

アウトリガ張出幅 \ カウンタウエイト	98 t	78 t	58 t	47 t	25 t
8.5 m	○	○	○	○	○
8.0 m	○	○	○	○	○
6.8 m	△	○	○	○	○

◆定格総荷重は、つり具質量とフック質量(80トンフック:1,550kg、35トンフック:950kg、12.2トンフック:440kg)を含んだ値を示します。

◆定格総荷重は、ブームとジブのたわみを含んだ実際の作業半径に基づいています。

◆各ブーム長さにおける各伸縮ブームの伸長状態(伸長割合%)は、下表のとおりです。

ブーム長さ	40.4 m	45.4 m	50.5 m	55.6 m	60.0 m
伸縮ブーム1	90	90	90	90	100
伸縮ブーム2	90	90	90	90	100
伸縮ブーム3	45	90	90	90	100
伸縮ブーム4	0	0	45	90	100

◆Bピン(ブーム固定ピン)を挿入していないときの定格総荷重は、26.6t以下になります。

◆定格総荷重表中の標準巻掛本数よりも少ない本数で使用する場合、最大荷重の上限は下表のとおりです。

巻掛本数	4本	3本	2本	1本
最大荷重	47.4t	35.9t	24.1t	12.2t

◆定格総荷重は、アウトリガを水平堅土上に設置したときの値です。

◆定格総荷重表は、風による影響を含んでいません。瞬間最大風速が10m/s以上の風速では、クレーン作業を中止してください。

定格総荷重表中の線、および用語説明

◆太線より上側はクレーンの強度に、下側はクレーンの安定に基づいています。

◆「 θ (°)」は、無負荷状態で作動可能なブーム起伏角度範囲を示します。

カウンタウエイト 98t、アウトリガ張出幅 8.5m

ブーム+6.0mフィックスジブ

単位:t

ブーム長さ(m) 作業半径(m)	40.4	45.4	50.5	55.6	60.0
8.0	50.2				
9.0	47.1	40.4			
10.0	44.4	38.3	30.2		
11.0	42.1	36.4	28.7	25.2	
12.0	40.0	34.7	27.3	24.0	
14.0	36.4	31.9	25.0	21.9	20.8
16.0	33.5	29.4	23.1	20.2	19.2
18.0	31.0	27.2	21.5	18.7	17.8
20.0	28.9	25.3	20.1	17.5	16.6
22.0	27.1	23.7	18.9	16.4	15.6
24.0	25.5	22.2	17.8	15.5	14.7
26.0	24.1	21.0	16.9	14.6	13.9
28.0	22.7	19.8	16.1	13.9	13.2
30.0	21.2	18.8	15.4	13.2	12.5
32.0	19.5	18.0	14.7	12.6	12.0
34.0	18.0	17.2	14.1	12.1	11.4
36.0	16.6	16.2	13.6	11.6	11.0
38.0	15.4	15.0	13.1	11.2	10.5
40.0	14.3	13.9	12.7	10.8	10.1
42.0	13.3	12.9	12.3	10.4	9.8
44.0	11.0	12.1	12.0	10.1	9.5
46.0		11.3	11.3	9.7	9.1
48.0		10.5	10.5	9.5	8.9
50.0			9.9	9.2	8.6
54.0			7.9	8.7	8.2
58.0				7.7	7.3
62.0					6.5
$\theta(^{\circ})$	10~ 82	16~ 82	10~ 82	16~ 82	17~ 82
標準フック	80t		35t		
フック重量	1550kg		950kg		
標準巻掛本数	5	4	3		2

カウンタウエイト 98t、アウトリガ張出幅 8.5m

ブーム+12.0mフィックスジブ

単位:t

ブーム長さ(m) 作業半径(m)	40.4	45.4	50.5	55.6	60.0
9.0	43.1				
10.0	40.6				
11.0	38.4	32.8			
12.0	36.4	31.2	24.6		
14.0	33.0	28.5	22.4	20.0	
16.0	30.3	26.3	20.6	18.5	17.4
18.0	28.0	24.4	19.1	17.1	16.1
20.0	26.0	22.8	17.8	15.9	15.0
22.0	24.3	21.4	16.7	14.9	14.1
24.0	22.8	20.2	15.7	14.0	13.2
26.0	21.5	19.1	14.8	13.2	12.5
28.0	20.3	18.0	14.1	12.5	11.8
30.0	19.3	17.1	13.4	11.8	11.2
32.0	18.4	16.2	12.7	11.3	10.6
34.0	17.5	15.5	12.2	10.7	10.1
36.0	16.3	14.8	11.7	10.3	9.7
38.0	15.1	14.1	11.2	9.8	9.3
40.0	14.0	13.6	10.8	9.4	8.9
42.0	13.0	12.7	10.4	9.1	8.6
44.0	12.1	11.8	10.1	8.8	8.2
46.0	11.4	11.0	9.7	8.5	7.9
48.0	10.6	10.3	9.5	8.2	7.7
50.0	8.7	9.6	9.2	7.9	7.4
54.0		8.4	8.4	7.5	7.0
58.0			7.4	7.1	6.3
62.0				6.5	5.7
66.0				2.5	5.2
70.0					3.3
$\theta(^{\circ})$	10~ 83	16~ 83	19~ 83	0~ 83	0~ 83
標準フック	80t		35t		
フック重量	1550kg		950kg		
標準巻掛本数	4	3		2	

カウンタウエイト 98t、アウトリガ張出幅 8.5m

ブーム+18.0mフィックスジブ

単位:t

ブーム長さ(m) 作業半径(m)	40.4	45.4	50.5	55.6	60.0
11.0	32.8				
12.0	31.4	28.5			
14.0	29.0	25.9	20.7	18.1	
16.0	26.9	23.9	19.0	16.7	15.8
18.0	25.0	22.1	17.6	15.5	14.7
20.0	23.4	20.6	16.3	14.5	13.8
22.0	22.0	19.3	15.3	13.6	12.9
24.0	20.7	18.1	14.3	12.8	12.1
26.0	19.6	17.1	13.5	12.0	11.4
28.0	18.3	16.2	12.8	11.4	10.8
30.0	17.1	15.4	12.1	10.8	10.2
32.0	16.1	14.7	11.5	10.2	9.7
34.0	15.2	14.0	11.0	9.7	9.2
36.0	14.4	13.4	10.5	9.3	8.8
38.0	13.6	12.9	10.0	8.9	8.4
40.0	13.0	12.4	9.6	8.5	8.0
42.0	12.4	11.9	9.2	8.1	7.7
44.0	11.8	11.4	8.9	7.8	7.4
46.0	11.3	10.9	8.6	7.5	7.1
48.0	10.5	10.1	8.3	7.2	6.8
50.0	9.9	9.5	8.0	7.0	6.6
54.0	8.7	8.3	7.6	6.5	6.0
58.0		7.3	7.2	6.2	5.4
62.0			6.4	5.8	4.8
66.0			5.0	5.6	4.4
70.0				4.9	4.0
74.0					3.7
$\theta(^{\circ})$	19~ 83	22~ 83	11~ 83	15~ 83	17~ 83
標準フック	35t				
フック重量	950kg				
標準巻掛本数	3			2	

カウンタウエイト 98t、アウトリガ張出幅 8.5m

ブーム+24.0mフィックスジブ

単位:t

ブーム長さ(m) 作業半径(m)	40.4	45.4	50.5	55.6	60.0
12.0	23.8				
14.0	22.2	21.4			
16.0	20.8	20.2	17.1	15.0	
18.0	19.5	19.1	15.9	13.9	13.3
20.0	18.2	18.1	14.8	13.0	12.4
22.0	17.1	17.0	13.9	12.2	11.6
24.0	16.1	16.1	13.0	11.4	10.9
26.0	15.0	15.3	12.2	10.8	10.3
28.0	14.0	14.5	11.5	10.2	9.8
30.0	13.2	13.8	10.9	9.7	9.3
32.0	12.4	13.2	10.3	9.2	8.8
34.0	11.7	12.6	9.8	8.8	8.3
36.0	11.1	12.0	9.4	8.3	7.9
38.0	10.5	11.5	8.9	8.0	7.5
40.0	9.9	10.9	8.5	7.6	7.2
42.0	9.4	10.4	8.2	7.3	6.9
44.0	9.0	9.9	7.9	6.9	6.6
46.0	8.5	9.4	7.5	6.7	6.3
48.0	8.1	9.0	7.3	6.4	6.0
50.0	7.8	8.6	7.0	6.1	5.7
54.0	7.1	7.9	6.5	5.7	5.0
58.0	6.6	7.0	6.1	5.3	4.4
62.0	5.2	6.2	5.8	5.0	3.9
66.0		5.4	5.3	4.7	3.5
70.0			4.6	4.3	3.1
74.0				4.0	2.8
78.0					2.5
$\theta(^{\circ})$	9~ 83	15~ 83	18~ 83	21~ 83	22~ 83
標準フック	35t				
フック重量	950kg				
標準巻掛本数			2		

フィックスジブ

カウンタウエイト 98t、アウトリガ張出幅 8.0m
ブーム+6.0mフィックスジブ

		単位:t				
ブーム長さ(m) 作業半径(m)	40.4	45.4	50.5	55.6	60.0	
8.0	50.2					
9.0	47.1	40.4				
10.0	44.4	38.3	30.2			
11.0	42.1	36.4	28.7	25.2		
12.0	40.0	34.7	27.3	24.0		
14.0	36.4	31.9	25.0	21.9	20.8	
16.0	33.5	29.4	23.1	20.2	19.2	
18.0	31.0	27.2	21.5	18.7	17.8	
20.0	28.9	25.3	20.1	17.5	16.6	
22.0	27.1	23.7	18.9	16.4	15.6	
24.0	25.5	22.2	17.8	15.5	14.7	
26.0	24.1	21.0	16.9	14.6	13.9	
28.0	22.7	19.8	16.1	13.9	13.2	
30.0	21.2	18.8	15.4	13.2	12.5	
32.0	19.5	18.0	14.7	12.6	12.0	
34.0	18.0	17.2	14.1	12.1	11.4	
36.0	16.6	16.2	13.6	11.6	11.0	
38.0	15.4	15.0	13.1	11.2	10.5	
40.0	14.3	13.9	12.7	10.8	10.1	
42.0	13.3	12.9	12.3	10.4	9.8	
44.0	11.0	12.1	12.0	10.1	9.5	
46.0		11.3	11.3	9.7	9.1	
48.0		10.5	10.5	9.5	8.9	
50.0			9.9	9.2	8.6	
54.0			7.9	8.7	8.2	
58.0				7.6	7.3	
62.0					6.4	
θ(°)	10~ 82	16~ 82	10~ 82	16~ 82	17~ 82	
標準フック	80t		35t			
フック重量	1550kg		950kg			
標準巻掛本数	5	4	3		2	

カウンタウエイト 98t、アウトリガ張出幅 8.0m
ブーム+12.0mフィックスジブ

		単位:t				
ブーム長さ(m) 作業半径(m)	40.4	45.4	50.5	55.6	60.0	
9.0	43.1					
10.0	40.6					
11.0	38.4	32.8				
12.0	36.4	31.2	24.6			
14.0	33.0	28.5	22.4	20.0		
16.0	30.3	26.3	20.6	18.5	17.4	
18.0	28.0	24.4	19.1	17.1	16.1	
20.0	26.0	22.8	17.8	15.9	15.0	
22.0	24.3	21.4	16.7	14.9	14.1	
24.0	22.8	20.2	15.7	14.0	13.2	
26.0	21.5	19.1	14.8	13.2	12.5	
28.0	20.3	18.0	14.1	12.5	11.8	
30.0	19.3	17.1	13.4	11.8	11.2	
32.0	18.4	16.2	12.7	11.3	10.6	
34.0	17.5	15.5	12.2	10.7	10.1	
36.0	16.3	14.8	11.7	10.3	9.7	
38.0	15.1	14.1	11.2	9.8	9.3	
40.0	14.0	13.6	10.8	9.4	8.9	
42.0	13.0	12.7	10.4	9.1	8.6	
44.0	12.1	11.8	10.1	8.8	8.2	
46.0	11.4	11.0	9.7	8.5	7.9	
48.0	10.6	10.3	9.5	8.2	7.7	
50.0	8.7	9.6	9.2	7.9	7.4	
54.0		8.3	8.4	7.5	7.0	
58.0			7.3	7.1	6.3	
62.0				6.5	5.7	
66.0				2.5	5.2	
70.0					3.3	
θ(°)	10~ 83	16~ 83	19~ 83	0~ 83	0~ 83	
標準フック	80t		35t			
フック重量	1550kg		950kg			
標準巻掛本数	4	3		2		

カウンタウエイト 98t、アウトリガ張出幅 8.0m
ブーム+18.0mフィックスジブ

		単位:t				
ブーム長さ(m) 作業半径(m)	40.4	45.4	50.5	55.6	60.0	
11.0	32.8					
12.0	31.4	28.5				
14.0	29.0	25.9	20.7	18.1		
16.0	26.9	23.9	19.0	16.7	15.8	
18.0	25.0	22.1	17.6	15.5	14.7	
20.0	23.4	20.6	16.3	14.5	13.8	
22.0	22.0	19.3	15.3	13.6	12.9	
24.0	20.7	18.1	14.3	12.8	12.1	
26.0	19.6	17.1	13.5	12.0	11.4	
28.0	18.3	16.2	12.8	11.4	10.8	
30.0	17.1	15.4	12.1	10.8	10.2	
32.0	16.1	14.7	11.5	10.2	9.7	
34.0	15.2	14.0	11.0	9.7	9.2	
36.0	14.4	13.4	10.5	9.3	8.8	
38.0	13.6	12.9	10.0	8.9	8.4	
40.0	13.0	12.4	9.6	8.5	8.0	
42.0	12.4	11.9	9.2	8.1	7.7	
44.0	11.8	11.4	8.9	7.8	7.4	
46.0	11.3	10.9	8.6	7.5	7.1	
48.0	10.5	10.1	8.3	7.2	6.8	
50.0	9.9	9.5	8.0	7.0	6.6	
54.0	8.7	8.3	7.6	6.5	6.0	
58.0		7.3	7.2	6.2	5.4	
62.0			6.4	5.8	4.8	
66.0			5.0	5.6	4.4	
70.0				4.7	4.0	
74.0					3.7	
θ(°)	19~ 83	22~ 83	11~ 83	15~ 83	17~ 83	
標準フック	35t					
フック重量	950kg					
標準巻掛本数	3			2		

カウンタウエイト 98t、アウトリガ張出幅 8.0m
ブーム+24.0mフィックスジブ

		単位:t				
ブーム長さ(m) 作業半径(m)	40.4	45.4	50.5	55.6	60.0	
12.0	23.8					
14.0	22.2	21.4				
16.0	20.8	20.2	17.1	15.0		
18.0	19.5	19.1	15.9	13.9	13.3	
20.0	18.2	18.1	14.8	13.0	12.4	
22.0	17.1	17.0	13.9	12.2	11.6	
24.0	16.1	16.1	13.0	11.4	10.9	
26.0	15.0	15.3	12.2	10.8	10.3	
28.0	14.0	14.5	11.5	10.2	9.8	
30.0	13.2	13.8	10.9	9.7	9.3	
32.0	12.4	13.2	10.3	9.2	8.8	
34.0	11.7	12.6	9.8	8.8	8.3	
36.0	11.1	12.0	9.4	8.3	7.9	
38.0	10.5	11.5	8.9	8.0	7.5	
40.0	9.9	10.9	8.5	7.6	7.2	
42.0	9.4	10.4	8.2	7.3	6.9	
44.0	9.0	9.9	7.9	6.9	6.6	
46.0	8.5	9.4	7.5	6.7	6.3	
48.0	8.1	9.0	7.3	6.4	6.0	
50.0	7.8	8.6	7.0	6.1	5.7	
54.0	7.1	7.9	6.5	5.7	5.0	
58.0	6.6	7.0	6.1	5.3	4.4	
62.0	5.2	6.2	5.8	5.0	3.9	
66.0		5.2	5.3	4.7	3.5	
70.0			4.4	4.3	3.1	
74.0				3.7	2.8	
78.0					2.5	
θ(°)	9~ 83	15~ 83	18~ 83	21~ 83	22~ 83	
標準フック	35t					
フック重量	950kg					
標準巻掛本数	2					

カウンタウエイト 78t、アウトリガ張出幅 8.5m

ブーム+6.0mフィックスジブ

単位:t

ブーム長さ(m) 作業半径(m)	40.4	45.4	50.5	55.6	60.0
8.0	50.2				
9.0	47.1	40.4			
10.0	44.4	38.3	30.2		
11.0	42.1	36.4	28.7	25.2	
12.0	40.0	34.7	27.3	24.0	
14.0	36.4	31.9	25.0	21.9	20.8
16.0	33.5	29.4	23.1	20.2	19.2
18.0	31.0	27.2	21.5	18.7	17.8
20.0	28.9	25.3	20.1	17.5	16.6
22.0	27.1	23.7	18.9	16.4	15.6
24.0	25.5	22.2	17.8	15.5	14.7
26.0	24.1	21.0	16.9	14.6	13.9
28.0	22.1	19.8	16.1	13.9	13.2
30.0	19.7	18.8	15.4	13.2	12.5
32.0	17.6	18.0	14.7	12.6	12.0
34.0	15.9	16.2	14.1	12.1	11.4
36.0	14.3	14.7	13.6	11.6	11.0
38.0	13.0	13.3	13.1	11.2	10.5
40.0	11.7	12.0	12.6	10.8	10.1
42.0	10.6	10.9	11.5	10.4	9.8
44.0	9.6	9.9	10.5	10.1	9.5
46.0		8.9	9.5	9.7	9.1
48.0		8.0	8.6	9.1	8.9
50.0			7.8	8.3	8.3
54.0			6.4	6.8	6.8
58.0				5.6	5.5
62.0					4.5
θ (°)	10~ 82	16~ 82	10~ 82	16~ 82	17~ 82
標準フック	80t		35t		
フック重量	1550kg		950kg		
標準巻掛本数	5	4	3		2

カウンタウエイト 78t、アウトリガ張出幅 8.5m

ブーム+12.0mフィックスジブ

単位:t

ブーム長さ(m) 作業半径(m)	40.4	45.4	50.5	55.6	60.0
9.0	43.1				
10.0	40.6				
11.0	38.4	32.8			
12.0	36.4	31.2	24.6		
14.0	33.0	28.5	22.4	20.0	
16.0	30.3	26.3	20.6	18.5	17.4
18.0	28.0	24.4	19.1	17.1	16.1
20.0	26.0	22.8	17.8	15.9	15.0
22.0	24.3	21.4	16.7	14.9	14.1
24.0	22.8	20.2	15.7	14.0	13.2
26.0	21.5	19.1	14.8	13.2	12.5
28.0	20.3	18.0	14.1	12.5	11.8
30.0	19.3	17.1	13.4	11.8	11.2
32.0	18.2	16.2	12.7	11.3	10.6
34.0	16.4	15.5	12.2	10.7	10.1
36.0	14.8	14.8	11.7	10.3	9.7
38.0	13.4	13.7	11.2	9.8	9.3
40.0	12.2	12.4	10.8	9.4	8.9
42.0	11.1	11.3	10.4	9.1	8.6
44.0	10.1	10.3	10.1	8.8	8.2
46.0	9.1	9.3	9.7	8.5	7.9
48.0	8.2	8.4	8.8	8.2	7.7
50.0	7.4	7.6	8.0	7.9	7.4
54.0		6.1	6.5	6.9	6.8
58.0			5.3	5.7	5.5
62.0				4.6	4.4
66.0				2.5	3.5
70.0					2.8
θ (°)	10~ 83	16~ 83	19~ 83	0~ 83	0~ 83
標準フック	80t		35t		
フック重量	1550kg		950kg		
標準巻掛本数	4	3		2	

カウンタウエイト 78t、アウトリガ張出幅 8.5m

ブーム+18.0mフィックスジブ

単位:t

ブーム長さ(m) 作業半径(m)	40.4	45.4	50.5	55.6	60.0
11.0	32.8				
12.0	31.4	28.5			
14.0	29.0	25.9	20.7	18.1	
16.0	26.9	23.9	19.0	16.7	15.8
18.0	25.0	22.1	17.6	15.5	14.7
20.0	23.4	20.6	16.3	14.5	13.8
22.0	22.0	19.3	15.3	13.6	12.9
24.0	20.7	18.1	14.3	12.8	12.1
26.0	19.6	17.1	13.5	12.0	11.4
28.0	18.3	16.2	12.8	11.4	10.8
30.0	17.1	15.4	12.1	10.8	10.2
32.0	16.1	14.7	11.5	10.2	9.7
34.0	15.2	14.0	11.0	9.7	9.2
36.0	14.4	13.4	10.5	9.3	8.8
38.0	13.6	12.9	10.0	8.9	8.4
40.0	12.7	12.4	9.6	8.5	8.0
42.0	11.6	11.6	9.2	8.1	7.7
44.0	10.6	10.6	8.9	7.8	7.4
46.0	9.7	9.7	8.6	7.5	7.1
48.0	8.7	8.8	8.3	7.2	6.8
50.0	7.9	7.9	8.0	7.0	6.6
54.0	6.5	6.5	6.9	6.5	6.0
58.0		5.3	5.6	5.8	5.4
62.0			4.5	4.8	4.6
66.0			3.6	3.8	3.6
70.0				3.0	2.8
74.0					2.1
θ (°)	19~ 83	22~ 83	11~ 83	15~ 83	17~ 83
標準フック	35t				
フック重量	950kg				
標準巻掛本数	3		2		

カウンタウエイト 78t、アウトリガ張出幅 8.5m

ブーム+24.0mフィックスジブ

単位:t

ブーム長さ(m) 作業半径(m)	40.4	45.4	50.5	55.6	60.0
12.0	23.8				
14.0	22.2	21.4			
16.0	20.8	20.2	17.1	15.0	
18.0	19.5	19.1	15.9	13.9	13.3
20.0	18.2	18.1	14.8	13.0	12.4
22.0	17.1	17.0	13.9	12.2	11.6
24.0	16.1	16.1	13.0	11.4	10.9
26.0	15.0	15.3	12.2	10.8	10.3
28.0	14.0	14.5	11.5	10.2	9.8
30.0	13.2	13.8	10.9	9.7	9.3
32.0	12.4	13.2	10.3	9.2	8.8
34.0	11.7	12.6	9.8	8.8	8.3
36.0	11.1	12.0	9.4	8.3	7.9
38.0	10.5	11.5	8.9	8.0	7.5
40.0	9.9	10.9	8.5	7.6	7.2
42.0	9.4	10.4	8.2	7.3	6.9
44.0	9.0	9.9	7.9	6.9	6.6
46.0	8.5	9.4	7.5	6.7	6.3
48.0	8.1	9.0	7.3	6.4	6.0
50.0	7.8	8.1	7.0	6.1	5.7
54.0	6.7	6.6	6.5	5.7	5.0
58.0	5.4	5.4	5.6	5.3	4.4
62.0	4.4	4.3	4.5	4.6	3.9
66.0		3.4	3.5	3.7	3.5
70.0			2.7	2.9	2.6
74.0				2.2	1.9
θ (°)	9~ 83	15~ 83	18~ 83	21~ 83	29~ 83
標準フック	35t				
フック重量	950kg				
標準巻掛本数	2				

フィックスジブ

カウンタウエイト 78t、アウトリガ張出幅 8.0m

ブーム+6.0mフィックスジブ

単位:t

ブーム長さ(m) 作業半径(m)	40.4	45.4	50.5	55.6	60.0
8.0	50.2				
9.0	47.1	40.4			
10.0	44.4	38.3	30.2		
11.0	42.1	36.4	28.7	25.2	
12.0	40.0	34.7	27.3	24.0	
14.0	36.4	31.9	25.0	21.9	20.8
16.0	33.5	29.4	23.1	20.2	19.2
18.0	31.0	27.2	21.5	18.7	17.8
20.0	28.9	25.3	20.1	17.5	16.6
22.0	27.1	23.7	18.9	16.4	15.6
24.0	25.5	22.2	17.8	15.5	14.7
26.0	23.6	21.0	16.9	14.6	13.9
28.0	20.8	19.8	16.1	13.9	13.2
30.0	18.5	18.8	15.4	13.2	12.5
32.0	16.5	16.9	14.7	12.6	12.0
34.0	14.8	15.1	14.1	12.1	11.4
36.0	13.3	13.6	13.6	11.6	11.0
38.0	12.0	12.3	12.9	11.2	10.5
40.0	10.8	11.1	11.7	10.8	10.1
42.0	9.7	10.0	10.6	10.4	9.8
44.0	8.7	9.0	9.6	10.1	9.5
46.0		8.1	8.7	9.2	9.1
48.0		7.2	7.8	8.3	8.3
50.0			7.0	7.5	7.5
54.0			5.7	6.1	6.1
58.0				5.0	4.9
62.0					3.9
θ(°)	10~ 82	16~ 82	10~ 82	16~ 82	17~ 82
標準フック	80t		35t		
フック重量	1550kg		950kg		
標準巻掛本数	5	4	3		2

カウンタウエイト 78t、アウトリガ張出幅 8.0m

ブーム+12.0mフィックスジブ

単位:t

ブーム長さ(m) 作業半径(m)	40.4	45.4	50.5	55.6	60.0
9.0	43.1				
10.0	40.6				
11.0	38.4	32.8			
12.0	36.4	31.2	24.6		
14.0	33.0	28.5	22.4	20.0	
16.0	30.3	26.3	20.6	18.5	17.4
18.0	28.0	24.4	19.1	17.1	16.1
20.0	26.0	22.8	17.8	15.9	15.0
22.0	24.3	21.4	16.7	14.9	14.1
24.0	22.8	20.2	15.7	14.0	13.2
26.0	21.5	19.1	14.8	13.2	12.5
28.0	20.3	18.0	14.1	12.5	11.8
30.0	19.1	17.1	13.4	11.8	11.2
32.0	17.1	16.2	12.7	11.3	10.6
34.0	15.3	15.5	12.2	10.7	10.1
36.0	13.8	14.0	11.7	10.3	9.7
38.0	12.5	12.7	11.2	9.8	9.3
40.0	11.3	11.5	10.8	9.4	8.9
42.0	10.2	10.5	10.4	9.1	8.6
44.0	9.2	9.4	9.8	8.8	8.2
46.0	8.2	8.4	8.9	8.5	7.9
48.0	7.4	7.6	8.0	8.2	7.7
50.0	6.7	6.8	7.2	7.6	7.4
54.0		5.4	5.8	6.2	6.1
58.0			4.6	5.0	4.9
62.0				4.0	3.8
66.0				2.5	3.0
70.0					2.2
θ(°)	10~ 83	16~ 83	19~ 83	0~ 83	0~ 83
標準フック	80t		35t		
フック重量	1550kg		950kg		
標準巻掛本数	4	3		2	

カウンタウエイト 78t、アウトリガ張出幅 8.0m

ブーム+18.0mフィックスジブ

単位:t

ブーム長さ(m) 作業半径(m)	40.4	45.4	50.5	55.6	60.0
11.0	32.8				
12.0	31.4	28.5			
14.0	29.0	25.9	20.7	18.1	
16.0	26.9	23.9	19.0	16.7	15.8
18.0	25.0	22.1	17.6	15.5	14.7
20.0	23.4	20.6	16.3	14.5	13.8
22.0	22.0	19.3	15.3	13.6	12.9
24.0	20.7	18.1	14.3	12.8	12.1
26.0	19.6	17.1	13.5	12.0	11.4
28.0	18.3	16.2	12.8	11.4	10.8
30.0	17.1	15.4	12.1	10.8	10.2
32.0	16.1	14.7	11.5	10.2	9.7
34.0	15.2	14.0	11.0	9.7	9.2
36.0	14.4	13.4	10.5	9.3	8.8
38.0	13.0	12.9	10.0	8.9	8.4
40.0	11.8	11.9	9.6	8.5	8.0
42.0	10.7	10.8	9.2	8.1	7.7
44.0	9.8	9.8	8.9	7.8	7.4
46.0	8.8	8.9	8.6	7.5	7.1
48.0	7.9	8.0	8.3	7.2	6.8
50.0	7.1	7.2	7.6	7.0	6.6
54.0	5.8	5.8	6.1	6.4	6.0
58.0		4.6	4.9	5.2	5.0
62.0			3.9	4.2	4.0
66.0			3.1	3.3	3.1
70.0				2.5	2.3
74.0					1.6
θ(°)	19~ 83	22~ 83	11~ 83	15~ 83	17~ 83
標準フック	35t				
フック重量	950kg				
標準巻掛本数	3			2	

カウンタウエイト 78t、アウトリガ張出幅 8.0m

ブーム+24.0mフィックスジブ

単位:t

ブーム長さ(m) 作業半径(m)	40.4	45.4	50.5	55.6	60.0
12.0	23.8				
14.0	22.2	21.4			
16.0	20.8	20.2	17.1	15.0	
18.0	19.5	19.1	15.9	13.9	13.3
20.0	18.2	18.1	14.8	13.0	12.4
22.0	17.1	17.0	13.9	12.2	11.6
24.0	16.1	16.1	13.0	11.4	10.9
26.0	15.0	15.3	12.2	10.8	10.3
28.0	14.0	14.5	11.5	10.2	9.8
30.0	13.2	13.8	10.9	9.7	9.3
32.0	12.4	13.2	10.3	9.2	8.8
34.0	11.7	12.6	9.8	8.8	8.3
36.0	11.1	12.0	9.4	8.3	7.9
38.0	10.5	11.5	8.9	8.0	7.5
40.0	9.9	10.9	8.5	7.6	7.2
42.0	9.4	10.4	8.2	7.3	6.9
44.0	9.0	9.9	7.9	6.9	6.6
46.0	8.5	9.1	7.5	6.7	6.3
48.0	8.1	8.2	7.3	6.4	6.0
50.0	7.4	7.3	7.0	6.1	5.7
54.0	5.9	5.9	6.1	5.7	5.0
58.0	4.7	4.7	4.9	5.1	4.4
62.0	3.8	3.7	3.9	4.0	3.8
66.0		2.8	3.0	3.1	2.9
70.0			2.2	2.3	2.1
74.0				1.7	
θ(°)	9~ 83	15~ 83	18~ 83	21~ 83	35~ 83
標準フック	35t				
フック重量	950kg				
標準巻掛本数	2				

カウンタウエイト 78t、アウトリガ張出幅 6.8m

ブーム+6.0mフィックスジブ

単位:t

ブーム長さ(m) 作業半径(m)	40.4	45.4	50.5	55.6	60.0
8.0	50.2				
9.0	47.1	40.4			
10.0	44.4	38.3	30.2		
11.0	42.1	36.4	28.7	25.2	
12.0	40.0	34.7	27.3	24.0	
14.0	36.4	31.9	25.0	21.9	20.8
16.0	33.5	29.4	23.1	20.2	19.2
18.0	31.0	27.2	21.5	18.7	17.8
20.0	28.9	25.3	20.1	17.5	16.6
22.0	26.1	23.7	18.9	16.4	15.6
24.0	22.7	22.2	17.8	15.5	14.7
26.0	19.8	20.2	16.9	14.6	13.9
28.0	17.4	17.8	16.1	13.9	13.2
30.0	15.4	15.8	15.4	13.2	12.5
32.0	13.7	14.0	14.6	12.6	12.0
34.0	12.2	12.5	13.1	12.1	11.4
36.0	10.9	11.2	11.8	11.6	11.0
38.0	9.6	10.0	10.6	11.0	10.5
40.0	8.5	8.8	9.5	9.9	10.0
42.0	7.5	7.8	8.5	8.9	9.0
44.0	6.6	6.9	7.5	8.0	8.0
46.0		6.1	6.7	7.1	7.2
48.0		5.3	5.9	6.4	6.4
50.0			5.2	5.7	5.7
54.0			4.0	4.4	4.4
58.0				3.4	3.4
62.0					2.5
θ (°)	10~ 82	16~ 82	10~ 82	16~ 82	17~ 82
標準フック	80t		35t		
フック重量	1550kg		950kg		
標準巻掛本数	5	4	3		2

カウンタウエイト 78t、アウトリガ張出幅 6.8m

ブーム+12.0mフィックスジブ

単位:t

ブーム長さ(m) 作業半径(m)	40.4	45.4	50.5	55.6	60.0
9.0	43.1				
10.0	40.6				
11.0	38.4	32.8			
12.0	36.4	31.2	24.6		
14.0	33.0	28.5	22.4	20.0	
16.0	30.3	26.3	20.6	18.5	17.4
18.0	28.0	24.4	19.1	17.1	16.1
20.0	26.0	22.8	17.8	15.9	15.0
22.0	24.3	21.4	16.7	14.9	14.1
24.0	22.8	20.2	15.7	14.0	13.2
26.0	20.4	19.1	14.8	13.2	12.5
28.0	18.0	18.0	14.1	12.5	11.8
30.0	16.0	16.2	13.4	11.8	11.2
32.0	14.2	14.5	12.7	11.3	10.6
34.0	12.7	12.9	12.2	10.7	10.1
36.0	11.4	11.6	11.7	10.3	9.7
38.0	10.2	10.4	10.8	9.8	9.3
40.0	9.0	9.3	9.7	9.4	8.9
42.0	8.0	8.2	8.7	9.1	8.6
44.0	7.1	7.3	7.7	8.2	8.1
46.0	6.2	6.4	6.8	7.3	7.2
48.0	5.5	5.7	6.1	6.5	6.4
50.0	4.8	5.0	5.4	5.8	5.7
54.0		3.8	4.1	4.5	4.4
58.0			3.1	3.5	3.3
62.0				2.6	2.4
66.0				1.9	1.6
θ (°)	10~ 83	16~ 83	19~ 83	0~ 83	23~ 83
標準フック	80t		35t		
フック重量	1550kg		950kg		
標準巻掛本数	4	3		2	

カウンタウエイト 78t、アウトリガ張出幅 6.8m

ブーム+18.0mフィックスジブ

単位:t

ブーム長さ(m) 作業半径(m)	40.4	45.4	50.5	55.6	60.0
11.0	32.8				
12.0	31.4	28.5			
14.0	29.0	25.9	20.7	18.1	
16.0	26.9	23.9	19.0	16.7	15.8
18.0	25.0	22.1	17.6	15.5	14.7
20.0	23.4	20.6	16.3	14.5	13.8
22.0	22.0	19.3	15.3	13.6	12.9
24.0	20.7	18.1	14.3	12.8	12.1
26.0	19.6	17.1	13.5	12.0	11.4
28.0	18.3	16.2	12.8	11.4	10.8
30.0	16.5	15.4	12.1	10.8	10.2
32.0	14.8	14.7	11.5	10.2	9.7
34.0	13.2	13.3	11.0	9.7	9.2
36.0	11.9	11.9	10.5	9.3	8.8
38.0	10.7	10.8	10.0	8.9	8.4
40.0	9.6	9.7	9.6	8.5	8.0
42.0	8.6	8.6	9.1	8.1	7.7
44.0	7.6	7.7	8.1	7.8	7.4
46.0	6.8	6.8	7.2	7.5	7.1
48.0	6.0	6.0	6.5	6.7	6.5
50.0	5.3	5.3	5.7	6.0	5.8
54.0	4.1	4.1	4.5	4.7	4.5
58.0		3.1	3.4	3.6	3.5
62.0			2.5	2.7	2.5
66.0			1.7	1.9	1.7
θ (°)	19~ 83	22~ 83	11~ 83	26~ 83	33~ 83
標準フック	35t				
フック重量	950kg				
標準巻掛本数	3		2		

カウンタウエイト 78t、アウトリガ張出幅 6.8m

ブーム+24.0mフィックスジブ

単位:t

ブーム長さ(m) 作業半径(m)	40.4	45.4	50.5	55.6	60.0
12.0	23.8				
14.0	22.2	21.4			
16.0	20.8	20.2	17.1	15.0	
18.0	19.5	19.1	15.9	13.9	13.3
20.0	18.2	18.1	14.8	13.0	12.4
22.0	17.1	17.0	13.9	12.2	11.6
24.0	16.1	16.1	13.0	11.4	10.9
26.0	15.0	15.3	12.2	10.8	10.3
28.0	14.0	14.5	11.5	10.2	9.8
30.0	13.2	13.8	10.9	9.7	9.3
32.0	12.4	13.2	10.3	9.2	8.8
34.0	11.7	12.6	9.8	8.8	8.3
36.0	11.1	12.0	9.4	8.3	7.9
38.0	10.5	11.0	8.9	8.0	7.5
40.0	9.9	9.9	8.5	7.6	7.2
42.0	8.9	8.9	8.2	7.3	6.9
44.0	7.9	7.9	7.9	6.9	6.6
46.0	7.0	7.0	7.2	6.7	6.3
48.0	6.2	6.2	6.4	6.4	6.0
50.0	5.5	5.5	5.7	5.9	5.7
54.0	4.3	4.2	4.4	4.6	4.4
58.0	3.2	3.2	3.4	3.5	3.3
62.0	2.3	2.2	2.4	2.6	2.4
66.0		1.5	1.6	1.8	1.6
θ (°)	9~ 83	15~ 83	28~ 83	35~ 83	40~ 83
標準フック	35t				
フック重量	950kg				
標準巻掛本数	2				

フィックスジブ

カウンタウエイト 58t、アウトリガ張出幅 8.5m

ブーム+6.0mフィックスジブ

単位:t

ブーム長さ(m) 作業半径(m)	40.4	45.4	50.5	55.6	60.0
8.0	50.2				
9.0	47.1	40.4			
10.0	44.4	38.3	30.2		
11.0	42.1	36.4	28.7	25.2	
12.0	40.0	34.7	27.3	24.0	
14.0	36.4	31.9	25.0	21.9	20.8
16.0	33.5	29.4	23.1	20.2	19.2
18.0	31.0	27.2	21.5	18.7	17.8
20.0	28.9	25.3	20.1	17.5	16.6
22.0	25.4	23.7	18.9	16.4	15.6
24.0	21.8	22.2	17.8	15.5	14.7
26.0	19.0	19.4	16.9	14.6	13.9
28.0	16.6	17.0	16.1	13.9	13.2
30.0	14.6	14.9	15.4	13.2	12.5
32.0	12.8	13.2	13.8	12.6	12.0
34.0	11.4	11.7	12.3	12.1	11.4
36.0	10.0	10.4	11.0	11.4	11.0
38.0	8.7	9.1	9.8	10.2	10.3
40.0	7.6	8.0	8.7	9.2	9.2
42.0	6.6	7.0	7.7	8.2	8.2
44.0	5.8	6.1	6.7	7.2	7.3
46.0		5.3	5.9	6.4	6.4
48.0		4.6	5.2	5.6	5.7
50.0			4.5	5.0	5.0
54.0			3.4	3.8	3.7
58.0				2.8	2.7
62.0					1.9
$\theta(^{\circ})$	10~ 82	16~ 82	10~ 82	16~ 82	17~ 82
標準フック	80t		35t		
フック重量	1550kg		950kg		
標準巻掛本数	5	4	3		2

カウンタウエイト 58t、アウトリガ張出幅 8.5m

ブーム+12.0mフィックスジブ

単位:t

ブーム長さ(m) 作業半径(m)	40.4	45.4	50.5	55.6	60.0
9.0	43.1				
10.0	40.6				
11.0	38.4	32.8			
12.0	36.4	31.2	24.6		
14.0	33.0	28.5	22.4	20.0	
16.0	30.3	26.3	20.6	18.5	17.4
18.0	28.0	24.4	19.1	17.1	16.1
20.0	26.0	22.8	17.8	15.9	15.0
22.0	24.3	21.4	16.7	14.9	14.1
24.0	22.5	20.2	15.7	14.0	13.2
26.0	19.6	19.1	14.8	13.2	12.5
28.0	17.2	17.5	14.1	12.5	11.8
30.0	15.1	15.4	13.4	11.8	11.2
32.0	13.4	13.7	12.7	11.3	10.6
34.0	11.9	12.1	12.2	10.7	10.1
36.0	10.6	10.8	11.2	10.3	9.7
38.0	9.4	9.6	10.0	9.8	9.3
40.0	8.2	8.5	8.9	9.4	8.9
42.0	7.2	7.4	7.9	8.4	8.2
44.0	6.3	6.5	6.9	7.4	7.3
46.0	5.5	5.7	6.1	6.6	6.5
48.0	4.8	4.9	5.3	5.8	5.7
50.0	4.1	4.3	4.7	5.1	5.0
54.0		3.1	3.5	3.9	3.7
58.0			2.5	2.9	2.7
62.0				2.0	1.8
$\theta(^{\circ})$	10~ 83	16~ 83	19~ 83	22~ 83	31~ 83
標準フック	80t	35t			
フック重量	1550kg	950kg			
標準巻掛本数	4	3		2	

カウンタウエイト 58t、アウトリガ張出幅 8.5m

ブーム+18.0mフィックスジブ

単位:t

ブーム長さ(m) 作業半径(m)	40.4	45.4	50.5	55.6	60.0
11.0	32.8				
12.0	31.4	28.5			
14.0	29.0	25.9	20.7	18.1	
16.0	26.9	23.9	19.0	16.7	15.8
18.0	25.0	22.1	17.6	15.5	14.7
20.0	23.4	20.6	16.3	14.5	13.8
22.0	22.0	19.3	15.3	13.6	12.9
24.0	20.7	18.1	14.3	12.8	12.1
26.0	19.6	17.1	13.5	12.0	11.4
28.0	17.8	16.2	12.8	11.4	10.8
30.0	15.7	15.4	12.1	10.8	10.2
32.0	14.0	14.0	11.5	10.2	9.7
34.0	12.5	12.5	11.0	9.7	9.2
36.0	11.1	11.2	10.5	9.3	8.8
38.0	10.0	10.0	10.0	8.9	8.4
40.0	8.9	8.9	9.4	8.5	8.0
42.0	7.8	7.9	8.3	8.1	7.7
44.0	6.9	6.9	7.4	7.7	7.4
46.0	6.1	6.1	6.5	6.8	6.6
48.0	5.3	5.3	5.8	6.0	5.9
50.0	4.6	4.6	5.1	5.3	5.1
54.0	3.4	3.4	3.8	4.1	3.9
58.0		2.4	2.8	3.0	2.9
62.0			1.9	2.1	2.0
$\theta(^{\circ})$	19~ 83	22~ 83	24~ 83	33~ 83	38~ 83
標準フック	35t				
フック重量	950kg				
標準巻掛本数	3			2	

カウンタウエイト 58t、アウトリガ張出幅 8.5m

ブーム+24.0mフィックスジブ

単位:t

ブーム長さ(m) 作業半径(m)	40.4	45.4	50.5	55.6	60.0
12.0	23.8				
14.0	22.2	21.4			
16.0	20.8	20.2	17.1	15.0	
18.0	19.5	19.1	15.9	13.9	13.3
20.0	18.2	18.1	14.8	13.0	12.4
22.0	17.1	17.0	13.9	12.2	11.6
24.0	16.1	16.1	13.0	11.4	10.9
26.0	15.0	15.3	12.2	10.8	10.3
28.0	14.0	14.5	11.5	10.2	9.8
30.0	13.2	13.8	10.9	9.7	9.3
32.0	12.4	13.2	10.3	9.2	8.8
34.0	11.7	12.6	9.8	8.8	8.3
36.0	11.1	11.4	9.4	8.3	7.9
38.0	10.3	10.2	8.9	8.0	7.5
40.0	9.2	9.2	8.5	7.6	7.2
42.0	8.1	8.1	8.2	7.3	6.9
44.0	7.2	7.2	7.4	6.9	6.6
46.0	6.3	6.3	6.5	6.7	6.3
48.0	5.6	5.5	5.8	6.0	5.7
50.0	4.9	4.8	5.1	5.2	5.0
54.0	3.6	3.6	3.8	4.0	3.8
58.0	2.6	2.6	2.8	2.9	2.7
62.0	1.8	1.7	1.9	2.0	1.8
$\theta(^{\circ})$	9~ 83	26~ 83	34~ 83	40~ 83	44~ 83
標準フック	35t				
フック重量	950kg				
標準巻掛本数	2				

カウンタウエイト 58t、アウトリガ張出幅 8.0m
ブーム+6.0mフィックスジブ

ブーム長さ(m) 作業半径(m)	単位:t				
	40.4	45.4	50.5	55.6	60.0
8.0	50.2				
9.0	47.1	40.4			
10.0	44.4	38.3	30.2		
11.0	42.1	36.4	28.7	25.2	
12.0	40.0	34.7	27.3	24.0	
14.0	36.4	31.9	25.0	21.9	20.8
16.0	33.5	29.4	23.1	20.2	19.2
18.0	31.0	27.2	21.5	18.7	17.8
20.0	27.7	25.3	20.1	17.5	16.6
22.0	23.6	23.7	18.9	16.4	15.6
24.0	20.3	20.7	17.8	15.5	14.7
26.0	17.6	18.0	16.9	14.6	13.9
28.0	15.3	15.7	16.1	13.9	13.2
30.0	13.4	13.8	14.4	13.2	12.5
32.0	11.8	12.2	12.8	12.6	12.0
34.0	10.4	10.8	11.3	11.7	11.4
36.0	9.0	9.4	10.1	10.5	10.6
38.0	7.8	8.2	8.9	9.4	9.5
40.0	6.8	7.1	7.8	8.3	8.4
42.0	5.8	6.2	6.8	7.3	7.4
44.0	5.0	5.3	6.0	6.5	6.5
46.0		4.6	5.2	5.7	5.7
48.0		3.9	4.5	4.9	5.0
50.0			3.8	4.3	4.3
54.0			2.8	3.2	3.1
58.0				2.2	2.2
θ (°)	10~82	16~82	10~82	16~82	28~82
標準フック	80t		35t		
フック重量	1550kg		950kg		
標準巻掛本数	5	4	3		2

カウンタウエイト 58t、アウトリガ張出幅 8.0m
ブーム+12.0mフィックスジブ

ブーム長さ(m) 作業半径(m)	単位:t				
	40.4	45.4	50.5	55.6	60.0
9.0	43.1				
10.0	40.6				
11.0	38.4	32.8			
12.0	36.4	31.2	24.6		
14.0	33.0	28.5	22.4	20.0	
16.0	30.3	26.3	20.6	18.5	17.4
18.0	28.0	24.4	19.1	17.1	16.1
20.0	26.0	22.8	17.8	15.9	15.0
22.0	24.3	21.4	16.7	14.9	14.1
24.0	20.9	20.2	15.7	14.0	13.2
26.0	18.2	18.5	14.8	13.2	12.5
28.0	15.9	16.2	14.1	12.5	11.8
30.0	14.0	14.3	13.4	11.8	11.2
32.0	12.4	12.6	12.7	11.3	10.6
34.0	10.9	11.2	11.5	10.7	10.1
36.0	9.7	9.9	10.3	10.3	9.7
38.0	8.4	8.7	9.1	9.6	9.3
40.0	7.3	7.6	8.0	8.6	8.4
42.0	6.4	6.6	7.1	7.6	7.4
44.0	5.5	5.7	6.2	6.7	6.5
46.0	4.7	5.0	5.4	5.9	5.7
48.0	4.1	4.2	4.7	5.1	5.0
50.0	3.5	3.6	4.0	4.5	4.3
54.0		2.5	2.9	3.3	3.1
58.0			1.9	2.3	2.2
62.0				1.5	
θ (°)	10~83	16~83	19~83	22~83	37~83
標準フック	80t		35t		
フック重量	1550kg		950kg		
標準巻掛本数	4	3		2	

カウンタウエイト 58t、アウトリガ張出幅 8.0m
ブーム+18.0mフィックスジブ

ブーム長さ(m) 作業半径(m)	単位:t				
	40.4	45.4	50.5	55.6	60.0
11.0	32.8				
12.0	31.4	28.5			
14.0	29.0	25.9	20.7	18.1	
16.0	26.9	23.9	19.0	16.7	15.8
18.0	25.0	22.1	17.6	15.5	14.7
20.0	23.4	20.6	16.3	14.5	13.8
22.0	22.0	19.3	15.3	13.6	12.9
24.0	20.7	18.1	14.3	12.8	12.1
26.0	18.8	17.1	13.5	12.0	11.4
28.0	16.5	16.2	12.8	11.4	10.8
30.0	14.6	14.7	12.1	10.8	10.2
32.0	12.9	13.0	11.5	10.2	9.7
34.0	11.5	11.6	11.0	9.7	9.2
36.0	10.2	10.3	10.5	9.3	8.8
38.0	9.1	9.2	9.6	8.9	8.4
40.0	8.0	8.0	8.5	8.5	8.0
42.0	7.0	7.1	7.5	7.8	7.6
44.0	6.1	6.2	6.6	6.9	6.7
46.0	5.3	5.4	5.8	6.1	5.9
48.0	4.6	4.6	5.1	5.3	5.1
50.0	3.9	4.0	4.4	4.7	4.5
54.0	2.8	2.8	3.2	3.5	3.3
58.0		1.9	2.2	2.5	2.3
62.0				1.6	
θ (°)	19~83	22~83	32~83	33~83	43~83
標準フック	35t				
フック重量	950kg				
標準巻掛本数	3		2		

カウンタウエイト 58t、アウトリガ張出幅 8.0m
ブーム+24.0mフィックスジブ

ブーム長さ(m) 作業半径(m)	単位:t				
	40.4	45.4	50.5	55.6	60.0
12.0	23.8				
14.0	22.2	21.4			
16.0	20.8	20.2	17.1	15.0	
18.0	19.5	19.1	15.9	13.9	13.3
20.0	18.2	18.1	14.8	13.0	12.4
22.0	17.1	17.0	13.9	12.2	11.6
24.0	16.1	16.1	13.0	11.4	10.9
26.0	15.0	15.3	12.2	10.8	10.3
28.0	14.0	14.5	11.5	10.2	9.8
30.0	13.2	13.8	10.9	9.7	9.3
32.0	12.4	13.2	10.3	9.2	8.8
34.0	11.7	11.8	9.8	8.8	8.3
36.0	10.5	10.5	9.4	8.3	7.9
38.0	9.4	9.4	8.9	8.0	7.5
40.0	8.3	8.3	8.5	7.6	7.2
42.0	7.3	7.3	7.5	7.3	6.9
44.0	6.4	6.4	6.6	6.8	6.6
46.0	5.6	5.6	5.8	6.0	5.8
48.0	4.9	4.8	5.1	5.2	5.0
50.0	4.2	4.2	4.4	4.6	4.4
54.0	3.0	3.0	3.2	3.4	3.2
58.0	2.0	2.0	2.2	2.4	2.2
62.0				1.5	
θ (°)	24~83	33~83	40~83	40~83	48~83
標準フック	35t				
フック重量	950kg				
標準巻掛本数	2				

フィックスジブ

カウンタウエイト 58t、アウトリガ張出幅 6.8m

ブーム+6.0mフィックスジブ

単位:t

ブーム長さ(m) 作業半径(m)	40.4	45.4	50.5	55.6	60.0
8.0	50.2				
9.0	47.1	40.4			
10.0	44.4	38.3	30.2		
11.0	42.1	36.4	28.7	25.2	
12.0	40.0	34.7	27.3	24.0	
14.0	36.4	31.9	25.0	21.9	20.8
16.0	33.4	29.4	23.1	20.2	19.2
18.0	27.5	27.2	21.5	18.7	17.8
20.0	23.1	23.5	20.1	17.5	16.6
22.0	19.5	20.0	18.9	16.4	15.6
24.0	16.7	17.1	17.8	15.5	14.7
26.0	14.4	14.8	15.4	14.6	13.9
28.0	12.5	12.8	13.5	13.9	13.2
30.0	10.8	11.2	11.8	12.2	12.3
32.0	9.3	9.7	10.4	10.8	10.8
34.0	7.9	8.3	9.0	9.5	9.6
36.0	6.7	7.1	7.8	8.3	8.4
38.0	5.7	6.0	6.7	7.2	7.3
40.0	4.7	5.1	5.8	6.3	6.3
42.0	3.9	4.3	4.9	5.4	5.5
44.0	3.2	3.5	4.2	4.6	4.7
46.0		2.9	3.5	3.9	4.0
48.0			2.8	3.3	3.3
50.0			2.3	2.7	2.7
54.0				1.7	1.7
θ(°)	10~ 82	24~ 82	26~ 82	27~ 82	35~ 82
標準フック	80t		35t		
フック重量	1550kg		950kg		
標準巻掛本数	5	4	3		2

カウンタウエイト 58t、アウトリガ張出幅 6.8m

ブーム+12.0mフィックスジブ

単位:t

ブーム長さ(m) 作業半径(m)	40.4	45.4	50.5	55.6	60.0
9.0	43.1				
10.0	40.6				
11.0	38.4	32.8			
12.0	36.4	31.2	24.6		
14.0	33.0	28.5	22.4	20.0	
16.0	30.3	26.3	20.6	18.5	17.4
18.0	28.0	24.4	19.1	17.1	16.1
20.0	23.7	22.8	17.8	15.9	15.0
22.0	20.2	20.5	16.7	14.9	14.1
24.0	17.3	17.6	15.7	14.0	13.2
26.0	15.0	15.3	14.8	13.2	12.5
28.0	13.0	13.3	13.7	12.5	11.8
30.0	11.4	11.6	12.0	11.8	11.2
32.0	9.9	10.2	10.5	11.0	10.6
34.0	8.5	8.8	9.3	9.7	9.6
36.0	7.3	7.6	8.0	8.6	8.4
38.0	6.2	6.5	7.0	7.5	7.3
40.0	5.3	5.6	6.0	6.5	6.4
42.0	4.5	4.7	5.1	5.6	5.5
44.0	3.7	3.9	4.3	4.8	4.7
46.0	3.0	3.2	3.6	4.1	4.0
48.0	2.4	2.6	3.0	3.5	3.3
50.0		2.0	2.4	2.9	2.7
54.0				1.9	1.7
θ(°)	20~ 83	28~ 83	36~ 83	37~ 83	42~ 83
標準フック	80t	35t			
フック重量	1550kg	950kg			
標準巻掛本数	4	3		2	

カウンタウエイト 58t、アウトリガ張出幅 6.8m

ブーム+18.0mフィックスジブ

単位:t

ブーム長さ(m) 作業半径(m)	40.4	45.4	50.5	55.6	60.0
11.0	32.8				
12.0	31.4	28.5			
14.0	29.0	25.9	20.7	18.1	
16.0	26.9	23.9	19.0	16.7	15.8
18.0	25.0	22.1	17.6	15.5	14.7
20.0	23.4	20.6	16.3	14.5	13.8
22.0	20.8	19.3	15.3	13.6	12.9
24.0	18.0	18.0	14.3	12.8	12.1
26.0	15.6	15.7	13.5	12.0	11.4
28.0	13.6	13.7	12.8	11.4	10.8
30.0	11.9	12.0	12.1	10.8	10.2
32.0	10.5	10.6	11.0	10.2	9.7
34.0	9.2	9.3	9.7	9.7	9.2
36.0	8.0	8.0	8.5	8.8	8.6
38.0	6.9	6.9	7.4	7.7	7.5
40.0	5.9	6.0	6.4	6.7	6.5
42.0	5.1	5.1	5.6	5.8	5.7
44.0	4.3	4.3	4.8	5.0	4.9
46.0	3.6	3.6	4.1	4.3	4.1
48.0	2.9	3.0	3.4	3.7	3.5
50.0	2.4	2.4	2.8	3.1	2.9
54.0			1.8	2.0	1.9
θ(°)	30~ 83	38~ 83	38~ 83	44~ 83	48~ 83
標準フック	35t				
フック重量	950kg				
標準巻掛本数	3			2	

カウンタウエイト 58t、アウトリガ張出幅 6.8m

ブーム+24.0mフィックスジブ

単位:t

ブーム長さ(m) 作業半径(m)	40.4	45.4	50.5	55.6	60.0
12.0	23.8				
14.0	22.2	21.4			
16.0	20.8	20.2	17.1	15.0	
18.0	19.5	19.1	15.9	13.9	13.3
20.0	18.2	18.1	14.8	13.0	12.4
22.0	17.1	17.0	13.9	12.2	11.6
24.0	16.1	16.1	13.0	11.4	10.9
26.0	15.0	15.3	12.2	10.8	10.3
28.0	14.0	13.9	11.5	10.2	9.8
30.0	12.3	12.3	10.9	9.7	9.3
32.0	10.8	10.8	10.3	9.2	8.8
34.0	9.5	9.5	9.7	8.8	8.3
36.0	8.3	8.3	8.5	8.3	7.9
38.0	7.2	7.2	7.4	7.6	7.4
40.0	6.2	6.2	6.4	6.6	6.4
42.0	5.3	5.3	5.6	5.7	5.5
44.0	4.6	4.5	4.8	4.9	4.7
46.0	3.8	3.8	4.0	4.2	4.0
48.0	3.2	3.2	3.4	3.6	3.4
50.0	2.6	2.6	2.8	3.0	2.8
54.0	1.6	1.5	1.7	1.9	1.7
θ(°)	32~ 83	39~ 83	44~ 83	49~ 83	52~ 83
標準フック	35t				
フック重量	950kg				
標準巻掛本数	2				

カウンタウエイト 47t、アウトリガ張出幅 8.5m

ブーム+6.0mフィックスジブ

単位:t

ブーム長さ(m) 作業半径(m)	40.4	45.4	50.5	55.6	60.0
8.0	50.2				
9.0	47.1	40.4			
10.0	44.4	38.3	30.2		
11.0	42.1	36.4	28.7	25.2	
12.0	40.0	34.7	27.3	24.0	
14.0	36.4	31.9	25.0	21.9	20.8
16.0	33.5	29.4	23.1	20.2	19.2
18.0	30.2	27.2	21.5	18.7	17.8
20.0	25.1	25.3	20.1	17.5	16.6
22.0	21.2	21.6	18.9	16.4	15.6
24.0	18.1	18.5	17.8	15.5	14.7
26.0	15.6	16.0	16.6	14.6	13.9
28.0	13.5	13.8	14.5	13.9	13.2
30.0	11.7	12.1	12.7	13.1	12.5
32.0	10.2	10.5	11.1	11.6	11.6
34.0	8.7	9.1	9.8	10.2	10.3
36.0	7.4	7.8	8.6	9.1	9.1
38.0	6.3	6.7	7.4	7.9	8.0
40.0	5.3	5.7	6.4	6.9	6.9
42.0	4.5	4.8	5.5	6.0	6.0
44.0	3.7	4.0	4.7	5.2	5.2
46.0		3.3	3.9	4.4	4.4
48.0		2.7	3.3	3.8	3.8
50.0			2.7	3.2	3.2
54.0			1.7	2.1	2.1
θ (°)	10~ 82	16~ 82	10~ 82	27~ 82	35~ 82
標準フック	80t		35t		
フック重量	1550kg		950kg		
標準巻掛本数	5	4	3		2

カウンタウエイト 47t、アウトリガ張出幅 8.5m

ブーム+12.0mフィックスジブ

単位:t

ブーム長さ(m) 作業半径(m)	40.4	45.4	50.5	55.6	60.0
9.0	43.1				
10.0	40.6				
11.0	38.4	32.8			
12.0	36.4	31.2	24.6		
14.0	33.0	28.5	22.4	20.0	
16.0	30.3	26.3	20.6	18.5	17.4
18.0	28.0	24.4	19.1	17.1	16.1
20.0	25.9	22.8	17.8	15.9	15.0
22.0	21.9	21.4	16.7	14.9	14.1
24.0	18.8	19.1	15.7	14.0	13.2
26.0	16.2	16.5	14.8	13.2	12.5
28.0	14.1	14.3	14.1	12.5	11.8
30.0	12.3	12.5	12.9	11.8	11.2
32.0	10.7	11.0	11.4	11.3	10.6
34.0	9.4	9.7	10.0	10.5	10.1
36.0	8.1	8.4	8.8	9.3	9.2
38.0	6.9	7.2	7.6	8.2	8.0
40.0	5.9	6.2	6.6	7.1	7.0
42.0	5.0	5.3	5.7	6.2	6.1
44.0	4.2	4.5	4.9	5.4	5.2
46.0	3.5	3.7	4.1	4.6	4.5
48.0	2.9	3.1	3.5	3.9	3.8
50.0		2.5	2.9	3.3	3.2
54.0			1.8	2.2	2.1
θ (°)	20~ 83	28~ 83	29~ 83	37~ 83	42~ 83
標準フック	80t	35t			
フック重量	1550kg	950kg			
標準巻掛本数	4	3		2	

カウンタウエイト 47t、アウトリガ張出幅 8.5m

ブーム+18.0mフィックスジブ

単位:t

ブーム長さ(m) 作業半径(m)	40.4	45.4	50.5	55.6	60.0
11.0	32.8				
12.0	31.4	28.5			
14.0	29.0	25.9	20.7	18.1	
16.0	26.9	23.9	19.0	16.7	15.8
18.0	25.0	22.1	17.6	15.5	14.7
20.0	23.4	20.6	16.3	14.5	13.8
22.0	22.0	19.3	15.3	13.6	12.9
24.0	19.4	18.1	14.3	12.8	12.1
26.0	16.9	16.9	13.5	12.0	11.4
28.0	14.7	14.8	12.8	11.4	10.8
30.0	12.9	12.9	12.1	10.8	10.2
32.0	11.3	11.4	11.5	10.2	9.7
34.0	10.0	10.0	10.4	9.7	9.2
36.0	8.8	8.8	9.3	9.3	8.8
38.0	7.6	7.7	8.1	8.4	8.2
40.0	6.6	6.6	7.1	7.4	7.2
42.0	5.6	5.7	6.2	6.4	6.3
44.0	4.8	4.9	5.3	5.6	5.4
46.0	4.1	4.1	4.6	4.8	4.7
48.0	3.4	3.5	3.9	4.2	4.0
50.0	2.8	2.8	3.3	3.5	3.3
54.0	1.8	1.8	2.2	2.4	2.2
58.0				1.5	
θ (°)	19~ 83	31~ 83	38~ 83	39~ 83	48~ 83
標準フック	35t				
フック重量	950kg				
標準巻掛本数	3		2		

カウンタウエイト 47t、アウトリガ張出幅 8.5m

ブーム+24.0mフィックスジブ

単位:t

ブーム長さ(m) 作業半径(m)	40.4	45.4	50.5	55.6	60.0
12.0	23.8				
14.0	22.2	21.4			
16.0	20.8	20.2	17.1	15.0	
18.0	19.5	19.1	15.9	13.9	13.3
20.0	18.2	18.1	14.8	13.0	12.4
22.0	17.1	17.0	13.9	12.2	11.6
24.0	16.1	16.1	13.0	11.4	10.9
26.0	15.0	15.3	12.2	10.8	10.3
28.0	14.0	14.5	11.5	10.2	9.8
30.0	13.2	13.2	10.9	9.7	9.3
32.0	11.7	11.6	10.3	9.2	8.8
34.0	10.3	10.3	9.8	8.8	8.3
36.0	9.1	9.1	9.3	8.3	7.9
38.0	7.9	7.9	8.2	8.0	7.5
40.0	6.9	6.9	7.1	7.3	7.1
42.0	6.0	5.9	6.2	6.4	6.2
44.0	5.1	5.1	5.3	5.5	5.3
46.0	4.4	4.3	4.6	4.8	4.5
48.0	3.7	3.7	3.9	4.1	3.9
50.0	3.1	3.0	3.3	3.4	3.2
54.0	2.0	1.9	2.2	2.3	2.1
θ (°)	32~ 83	39~ 83	44~ 83	49~ 83	52~ 83
標準フック	35t				
フック重量	950kg				
標準巻掛本数	2				

フィックスジブ

カウンタウエイト 47t、アウトリガ張出幅 8.0m

ブーム+6.0mフィックスジブ

単位:t

ブーム長さ(m) 作業半径(m)	40.4	45.4	50.5	55.6	60.0
8.0	50.2				
9.0	47.1	40.4			
10.0	44.4	38.3	30.2		
11.0	42.1	36.4	28.7	25.2	
12.0	40.0	34.7	27.3	24.0	
14.0	36.4	31.9	25.0	21.9	20.8
16.0	33.5	29.4	23.1	20.2	19.2
18.0	28.0	27.2	21.5	18.7	17.8
20.0	23.3	23.7	20.1	17.5	16.6
22.0	19.6	20.0	18.9	16.4	15.6
24.0	16.7	17.1	17.8	15.5	14.7
26.0	14.3	14.7	15.4	14.6	13.9
28.0	12.3	12.7	13.4	13.8	13.2
30.0	10.7	11.0	11.7	12.1	12.2
32.0	9.1	9.6	10.2	10.6	10.7
34.0	7.7	8.2	8.9	9.4	9.4
36.0	6.5	6.9	7.7	8.2	8.2
38.0	5.5	5.9	6.6	7.1	7.1
40.0	4.5	4.9	5.6	6.1	6.2
42.0	3.7	4.1	4.7	5.2	5.3
44.0	3.0	3.3	4.0	4.5	4.5
46.0		2.7	3.3	3.8	3.8
48.0			2.7	3.1	3.1
50.0			2.1	2.6	2.6
54.0				1.6	1.5
$\theta(^{\circ})$	10~ 82	24~ 82	26~ 82	27~ 82	35~ 82
標準フック	80t		35t		
フック重量	1550kg		950kg		
標準巻掛本数	5	4	3		2

カウンタウエイト 47t、アウトリガ張出幅 8.0m

ブーム+12.0mフィックスジブ

単位:t

ブーム長さ(m) 作業半径(m)	40.4	45.4	50.5	55.6	60.0
9.0	43.1				
10.0	40.6				
11.0	38.4	32.8			
12.0	36.4	31.2	24.6		
14.0	33.0	28.5	22.4	20.0	
16.0	30.3	26.3	20.6	18.5	17.4
18.0	28.0	24.4	19.1	17.1	16.1
20.0	24.0	22.8	17.8	15.9	15.0
22.0	20.3	20.6	16.7	14.9	14.1
24.0	17.4	17.7	15.7	14.0	13.2
26.0	14.9	15.2	14.8	13.2	12.5
28.0	12.9	13.2	13.6	12.5	11.8
30.0	11.2	11.5	11.9	11.8	11.2
32.0	9.8	10.1	10.4	10.9	10.6
34.0	8.4	8.7	9.1	9.6	9.5
36.0	7.2	7.5	7.9	8.4	8.3
38.0	6.1	6.4	6.8	7.3	7.2
40.0	5.1	5.4	5.8	6.3	6.2
42.0	4.3	4.5	5.0	5.5	5.3
44.0	3.5	3.7	4.2	4.7	4.5
46.0	2.8	3.1	3.5	4.0	3.8
48.0		2.4	2.8	3.3	3.2
50.0		1.9	2.3	2.7	2.6
54.0				1.7	1.5
$\theta(^{\circ})$	26~ 83	28~ 83	36~ 83	37~ 83	42~ 83
標準フック	80t		35t		
フック重量	1550kg		950kg		
標準巻掛本数	4	3		2	

カウンタウエイト 47t、アウトリガ張出幅 8.0m

ブーム+18.0mフィックスジブ

単位:t

ブーム長さ(m) 作業半径(m)	40.4	45.4	50.5	55.6	60.0
11.0	32.8				
12.0	31.4	28.5			
14.0	29.0	25.9	20.7	18.1	
16.0	26.9	23.9	19.0	16.7	15.8
18.0	25.0	22.1	17.6	15.5	14.7
20.0	23.4	20.6	16.3	14.5	13.8
22.0	21.0	19.3	15.3	13.6	12.9
24.0	18.0	18.1	14.3	12.8	12.1
26.0	15.6	15.6	13.5	12.0	11.4
28.0	13.6	13.6	12.8	11.4	10.8
30.0	11.8	11.9	12.1	10.8	10.2
32.0	10.4	10.4	10.8	10.2	9.7
34.0	9.1	9.2	9.6	9.7	9.2
36.0	7.8	7.9	8.4	8.7	8.5
38.0	6.7	6.8	7.3	7.6	7.4
40.0	5.8	5.8	6.3	6.6	6.4
42.0	4.9	5.0	5.4	5.7	5.5
44.0	4.1	4.2	4.6	4.9	4.7
46.0	3.4	3.5	3.9	4.2	4.0
48.0	2.8	2.8	3.2	3.5	3.3
50.0	2.2	2.2	2.7	2.9	2.7
54.0			1.6	1.9	1.7
$\theta(^{\circ})$	30~ 83	38~ 83	38~ 83	44~ 83	48~ 83
標準フック	35t				
フック重量	950kg				
標準巻掛本数	3		2		

カウンタウエイト 47t、アウトリガ張出幅 8.0m

ブーム+24.0mフィックスジブ

単位:t

ブーム長さ(m) 作業半径(m)	40.4	45.4	50.5	55.6	60.0
12.0	23.8				
14.0	22.2	21.4			
16.0	20.8	20.2	17.1	15.0	
18.0	19.5	19.1	15.9	13.9	13.3
20.0	18.2	18.1	14.8	13.0	12.4
22.0	17.1	17.0	13.9	12.2	11.6
24.0	16.1	16.1	13.0	11.4	10.9
26.0	15.0	15.3	12.2	10.8	10.3
28.0	13.9	13.9	11.5	10.2	9.8
30.0	12.2	12.2	10.9	9.7	9.3
32.0	10.7	10.7	10.3	9.2	8.8
34.0	9.4	9.4	9.6	8.8	8.3
36.0	8.2	8.2	8.4	8.3	7.9
38.0	7.1	7.1	7.3	7.5	7.3
40.0	6.1	6.1	6.3	6.5	6.3
42.0	5.2	5.2	5.4	5.6	5.4
44.0	4.4	4.4	4.6	4.8	4.6
46.0	3.7	3.7	3.9	4.1	3.9
48.0	3.0	3.0	3.2	3.4	3.2
50.0	2.4	2.4	2.6	2.8	2.6
54.0			1.6	1.8	
$\theta(^{\circ})$	39~ 83	44~ 83	44~ 83	49~ 83	56~ 83
標準フック	35t				
フック重量	950kg				
標準巻掛本数	2				

カウンタウエイト 47t、アウトリガ張出幅 6.8m

ブーム+6.0mフィックスジブ

単位:t

ブーム長さ(m) 作業半径(m)	40.4	45.4	50.5	55.6	60.0
8.0	50.2				
9.0	47.1	40.4			
10.0	44.4	38.3	30.2		
11.0	42.1	36.4	28.7	25.2	
12.0	40.0	34.7	27.3	24.0	
14.0	35.3	31.9	25.0	21.9	20.8
16.0	28.1	28.6	23.1	20.2	19.2
18.0	23.0	23.4	21.5	18.7	17.8
20.0	19.0	19.5	20.1	17.5	16.6
22.0	16.0	16.4	17.0	16.4	15.6
24.0	13.5	13.9	14.5	15.0	14.7
26.0	11.5	11.8	12.5	12.9	13.0
28.0	9.7	10.1	10.7	11.2	11.2
30.0	8.1	8.5	9.3	9.7	9.8
32.0	6.7	7.1	7.9	8.4	8.4
34.0	5.5	5.9	6.6	7.1	7.2
36.0	4.4	4.8	5.5	6.1	6.1
38.0	3.5	3.9	4.6	5.1	5.2
40.0	2.7	3.1	3.8	4.3	4.3
42.0			3.0	3.5	3.5
44.0			2.3	2.8	2.8
46.0			1.7	2.2	2.2
48.0				1.6	1.7
$\theta (^{\circ})$	28~ 82	38~ 82	34~ 82	38~ 82	44~ 82
標準フック	80t		35t		
フック重量	1550kg		950kg		
標準巻掛本数	5	4	3	2	

カウンタウエイト 47t、アウトリガ張出幅 6.8m

ブーム+12.0mフィックスジブ

単位:t

ブーム長さ(m) 作業半径(m)	40.4	45.4	50.5	55.6	60.0
9.0	43.1				
10.0	40.6				
11.0	38.4	32.8			
12.0	36.4	31.2	24.6		
14.0	33.0	28.5	22.4	20.0	
16.0	28.9	26.3	20.6	18.5	17.4
18.0	23.7	24.0	19.1	17.1	16.1
20.0	19.7	20.0	17.8	15.9	15.0
22.0	16.6	16.9	16.7	14.9	14.1
24.0	14.1	14.4	14.8	14.0	13.2
26.0	12.1	12.3	12.7	13.2	12.5
28.0	10.3	10.6	11.0	11.4	11.3
30.0	8.8	9.1	9.5	9.9	9.8
32.0	7.3	7.6	8.1	8.6	8.5
34.0	6.1	6.4	6.9	7.4	7.3
36.0	5.0	5.3	5.8	6.3	6.2
38.0	4.1	4.4	4.8	5.3	5.2
40.0	3.3	3.5	4.0	4.5	4.3
42.0	2.5	2.8	3.2	3.7	3.6
44.0		2.1	2.5	3.0	2.9
46.0		1.5	1.9	2.4	2.2
48.0				1.8	1.7
$\theta (^{\circ})$	36~ 83	36~ 83	43~ 83	45~ 83	49~ 83
標準フック	80t	35t			
フック重量	1550kg	950kg			
標準巻掛本数	4	3	2		

カウンタウエイト 47t、アウトリガ張出幅 6.8m

ブーム+18.0mフィックスジブ

単位:t

ブーム長さ(m) 作業半径(m)	40.4	45.4	50.5	55.6	60.0
11.0	32.8				
12.0	31.4	28.5			
14.0	29.0	25.9	20.7	18.1	
16.0	26.9	23.9	19.0	16.7	15.8
18.0	24.4	22.1	17.6	15.5	14.7
20.0	20.4	20.5	16.3	14.5	13.8
22.0	17.3	17.3	15.3	13.6	12.9
24.0	14.7	14.8	14.3	12.8	12.1
26.0	12.7	12.7	13.1	12.0	11.4
28.0	10.9	11.0	11.4	11.4	10.8
30.0	9.4	9.5	9.9	10.1	10.0
32.0	8.0	8.1	8.6	8.9	8.7
34.0	6.8	6.9	7.3	7.6	7.4
36.0	5.7	5.8	6.2	6.5	6.3
38.0	4.7	4.8	5.3	5.5	5.4
40.0	3.9	4.0	4.4	4.7	4.5
42.0	3.1	3.2	3.6	3.9	3.7
44.0	2.4	2.5	2.9	3.2	3.0
46.0	1.8	1.9	2.3	2.6	2.4
48.0			1.7	2.0	
50.0				1.5	
$\theta (^{\circ})$	37~ 83	44~ 83	46~ 83	48~ 83	56~ 83
標準フック	35t				
フック重量	950kg				
標準巻掛本数	3		2		

カウンタウエイト 47t、アウトリガ張出幅 6.8m

ブーム+24.0mフィックスジブ

単位:t

ブーム長さ(m) 作業半径(m)	40.4	45.4	50.5	55.6	60.0
12.0	23.8				
14.0	22.2	21.4			
16.0	20.8	20.2	17.1	15.0	
18.0	19.5	19.1	15.9	13.9	13.3
20.0	18.2	18.1	14.8	13.0	12.4
22.0	17.1	17.0	13.9	12.2	11.6
24.0	15.1	15.1	13.0	11.4	10.9
26.0	13.0	13.0	12.2	10.8	10.3
28.0	11.2	11.2	11.4	10.2	9.8
30.0	9.8	9.8	9.9	9.7	9.3
32.0	8.4	8.4	8.6	8.8	8.6
34.0	7.1	7.1	7.4	7.6	7.3
36.0	6.0	6.0	6.3	6.5	6.2
38.0	5.1	5.0	5.3	5.5	5.3
40.0	4.2	4.2	4.4	4.6	4.4
42.0	3.4	3.4	3.6	3.8	3.6
44.0	2.7	2.7	2.9	3.1	2.9
46.0	2.1	2.1	2.3	2.5	
48.0	1.5	1.5	1.7		
$\theta (^{\circ})$	42~ 83	47~ 83	51~ 83	56~ 83	61~ 83
標準フック	35t				
フック重量	950kg				
標準巻掛本数	2				

フィックスジブ

カウンタウエイト 25t、アウトリガ張出幅 8.5m

ブーム+6.0mフィックスジブ

単位:t

ブーム長さ(m) 作業半径(m)	40.4	45.4	50.5	55.6	60.0
8.0	50.2				
9.0	47.1	40.4			
10.0	44.4	38.3	30.2		
11.0	42.1	36.4	28.7	25.2	
12.0	40.0	34.7	27.3	24.0	
14.0	31.7	31.9	25.0	21.9	20.8
16.0	24.7	25.2	23.1	20.2	19.2
18.0	19.7	20.2	20.9	18.7	17.8
20.0	16.0	16.4	17.1	17.5	16.6
22.0	13.1	13.5	14.2	14.7	14.8
24.0	10.8	11.2	11.9	12.3	12.4
26.0	8.8	9.3	10.0	10.4	10.5
28.0	7.1	7.6	8.4	8.8	8.9
30.0	5.6	6.1	6.9	7.4	7.5
32.0	4.4	4.8	5.6	6.1	6.2
34.0	3.3	3.7	4.5	5.0	5.1
36.0		2.8	3.5	4.0	4.1
38.0			2.6	3.2	3.2
40.0			1.9	2.4	2.4
42.0				1.7	
θ(°)	42~ 82	45~ 82	44~ 82	47~ 82	53~ 82
標準フック	80t		35t		
フック重量	1550kg		950kg		
標準巻掛本数	5	4	3		2

カウンタウエイト 25t、アウトリガ張出幅 8.5m

ブーム+12.0mフィックスジブ

単位:t

ブーム長さ(m) 作業半径(m)	40.4	45.4	50.5	55.6	60.0
9.0	43.1				
10.0	40.6				
11.0	38.4	32.8			
12.0	36.4	31.2	24.6		
14.0	32.7	28.5	22.4	20.0	
16.0	25.6	25.9	20.6	18.5	17.4
18.0	20.5	20.8	19.1	17.1	16.1
20.0	16.7	17.0	17.4	15.9	15.0
22.0	13.8	14.1	14.5	14.9	14.1
24.0	11.5	11.8	12.1	12.7	12.5
26.0	9.6	9.9	10.2	10.7	10.6
28.0	7.9	8.2	8.6	9.1	9.0
30.0	6.4	6.7	7.1	7.7	7.6
32.0	5.1	5.4	5.8	6.4	6.3
34.0	4.0	4.3	4.7	5.3	5.1
36.0	3.0	3.3	3.7	4.3	4.1
38.0		2.4	2.9	3.4	3.3
40.0		1.7	2.1	2.6	2.5
θ(°)	46~ 83	46~ 83	50~ 83	54~ 83	58~ 83
標準フック	80t		35t		
フック重量	1550kg		950kg		
標準巻掛本数	4	3		2	

カウンタウエイト 25t、アウトリガ張出幅 8.5m

ブーム+18.0mフィックスジブ

単位:t

ブーム長さ(m) 作業半径(m)	40.4	45.4	50.5	55.6	60.0
11.0	32.8				
12.0	31.4	28.5			
14.0	29.0	25.9	20.7	18.1	
16.0	26.4	23.9	19.0	16.7	15.8
18.0	21.3	21.4	17.6	15.5	14.7
20.0	17.5	17.5	16.3	14.5	13.8
22.0	14.5	14.6	15.0	13.6	12.9
24.0	12.1	12.2	12.7	12.8	12.1
26.0	10.2	10.3	10.7	11.0	10.8
28.0	8.6	8.7	9.1	9.3	9.2
30.0	7.1	7.2	7.7	8.0	7.8
32.0	5.8	5.9	6.4	6.7	6.5
34.0	4.7	4.7	5.2	5.5	5.3
36.0	3.7	3.8	4.2	4.5	4.3
38.0	2.8	2.9	3.4	3.6	3.5
40.0	2.1	2.1	2.6	2.9	
θ(°)	47~ 83	52~ 83	55~ 83	58~ 83	63~ 83
標準フック	35t				
フック重量	950kg				
標準巻掛本数	3		2		

カウンタウエイト 25t、アウトリガ張出幅 8.5m

ブーム+24.0mフィックスジブ

単位:t

ブーム長さ(m) 作業半径(m)	40.4	45.4	50.5	55.6	60.0
12.0	23.8				
14.0	22.2	21.4			
16.0	20.8	20.2	17.1	15.0	
18.0	19.5	19.1	15.9	13.9	13.3
20.0	17.9	17.9	14.8	13.0	12.4
22.0	14.9	14.9	13.9	12.2	11.6
24.0	12.6	12.6	12.8	11.4	10.9
26.0	10.6	10.6	10.8	10.8	10.3
28.0	9.0	9.0	9.2	9.3	9.2
30.0	7.5	7.5	7.8	8.0	7.7
32.0	6.2	6.2	6.4	6.6	6.4
34.0	5.1	5.0	5.3	5.5	5.3
36.0	4.1	4.0	4.3	4.5	4.3
38.0	3.2	3.2	3.4	3.6	
40.0	2.4	2.4			
θ(°)	52~ 83	56~ 83	61~ 83	63~ 83	67~ 83
標準フック	35t				
フック重量	950kg				
標準巻掛本数	2				

カウンタウエイト 25t、アウトリガ張出幅 8.0m

ブーム+6.0mフィックスジブ

単位:t

ブーム長さ(m) 作業半径(m)	40.4	45.4	50.5	55.6	60.0
8.0	50.2				
9.0	47.1	40.4			
10.0	44.4	38.3	30.2		
11.0	42.1	36.4	28.7	25.2	
12.0	38.7	34.7	27.3	24.0	
14.0	29.0	29.5	25.0	21.9	20.8
16.0	22.6	23.0	23.1	20.2	19.2
18.0	18.0	18.4	19.1	18.7	17.8
20.0	14.5	15.0	15.7	16.1	16.2
22.0	11.8	12.3	12.9	13.4	13.5
24.0	9.7	10.1	10.8	11.2	11.3
26.0	7.7	8.2	9.0	9.4	9.5
28.0	6.1	6.6	7.4	7.9	8.0
30.0	4.7	5.2	5.9	6.5	6.6
32.0	3.5	4.0	4.7	5.3	5.3
34.0	2.5	3.0	3.7	4.2	4.3
36.0			2.8	3.3	3.3
38.0			2.0	2.5	2.5
40.0				1.8	
$\theta (^{\circ})$	42~ 82	48~ 82	48~ 82	50~ 82	56~ 82
標準フック	80t		35t		
フック重量	1550kg		950kg		
標準巻掛本数	5	4	3		2

カウンタウエイト 25t、アウトリガ張出幅 8.0m

ブーム+12.0mフィックスジブ

単位:t

ブーム長さ(m) 作業半径(m)	40.4	45.4	50.5	55.6	60.0
9.0	43.1				
10.0	40.6				
11.0	38.4	32.8			
12.0	36.4	31.2	24.6		
14.0	29.9	28.5	22.4	20.0	
16.0	23.4	23.8	20.6	18.5	17.4
18.0	18.7	19.1	19.1	17.1	16.1
20.0	15.2	15.6	16.0	15.9	15.0
22.0	12.5	12.8	13.2	13.7	13.6
24.0	10.4	10.6	11.0	11.5	11.4
26.0	8.5	8.9	9.2	9.7	9.6
28.0	6.8	7.2	7.6	8.2	8.1
30.0	5.4	5.8	6.2	6.8	6.6
32.0	4.2	4.5	5.0	5.6	5.4
34.0	3.2	3.5	3.9	4.5	4.3
36.0		2.6	3.0	3.5	3.4
38.0		1.8	2.2	2.7	
$\theta (^{\circ})$	49~ 83	49~ 83	53~ 83	57~ 83	61~ 83
標準フック	80t		35t		
フック重量	1550kg		950kg		
標準巻掛本数	4	3		2	

カウンタウエイト 25t、アウトリガ張出幅 8.0m

ブーム+18.0mフィックスジブ

単位:t

ブーム長さ(m) 作業半径(m)	40.4	45.4	50.5	55.6	60.0
11.0	32.8				
12.0	31.4	28.5			
14.0	29.0	25.9	20.7	18.1	
16.0	24.2	23.9	19.0	16.7	15.8
18.0	19.5	19.6	17.6	15.5	14.7
20.0	16.0	16.0	16.3	14.5	13.8
22.0	13.2	13.3	13.7	13.6	12.9
24.0	11.0	11.1	11.5	11.8	11.6
26.0	9.2	9.3	9.7	10.0	9.8
28.0	7.6	7.7	8.2	8.4	8.3
30.0	6.2	6.3	6.8	7.1	6.9
32.0	5.0	5.0	5.5	5.8	5.6
34.0	3.9	4.0	4.4	4.7	4.6
36.0	3.0	3.0	3.5	3.8	3.6
38.0	2.1	2.2	2.7	3.0	
$\theta (^{\circ})$	49~ 83	54~ 83	57~ 83	60~ 83	64~ 83
標準フック	35t				
フック重量	950kg				
標準巻掛本数	3		2		

カウンタウエイト 25t、アウトリガ張出幅 8.0m

ブーム+24.0mフィックスジブ

単位:t

ブーム長さ(m) 作業半径(m)	40.4	45.4	50.5	55.6	60.0
12.0	23.8				
14.0	22.2	21.4			
16.0	20.8	20.2	17.1	15.0	
18.0	19.5	19.1	15.9	13.9	13.3
20.0	16.4	16.4	14.8	13.0	12.4
22.0	13.6	13.6	13.8	12.2	11.6
24.0	11.4	11.4	11.6	11.4	10.9
26.0	9.6	9.6	9.8	10.0	9.8
28.0	8.0	8.0	8.3	8.4	8.3
30.0	6.6	6.6	6.8	7.0	6.8
32.0	5.3	5.3	5.6	5.8	5.6
34.0	4.3	4.2	4.5	4.7	4.5
36.0	3.3	3.3	3.5	3.7	
38.0	2.5				
$\theta (^{\circ})$	54~ 83	60~ 83	62~ 83	65~ 83	68~ 83
標準フック	35t				
フック重量	950kg				
標準巻掛本数	2				

フィックスジブ

カウンタウエイト 25t、アウトリガ張出幅 6.8m
ブーム+6.0mフィックスジブ

単位:t

ブーム長さ(m) 作業半径(m)	40.4	45.4	50.5	55.6	60.0
8.0	50.2				
9.0	47.1	40.4			
10.0	42.8	38.3	30.2		
11.0	35.9	36.4	28.7	25.2	
12.0	30.6	31.2	27.3	24.0	
14.0	23.0	23.5	24.3	21.9	20.8
16.0	17.8	18.3	19.0	19.5	19.2
18.0	14.1	14.5	15.2	15.7	15.8
20.0	11.2	11.6	12.3	12.8	12.9
22.0	8.9	9.4	10.0	10.5	10.6
24.0	6.9	7.4	8.1	8.6	8.7
26.0	5.2	5.7	6.4	7.0	7.1
28.0	3.8	4.3	5.0	5.6	5.6
30.0	2.6	3.1	3.8	4.3	4.4
32.0			2.8	3.3	3.4
θ (°)	49~ 82	54~ 82	56~ 82	59~ 82	62~ 82
標準フック	80t		35t		
フック重量	1550kg		950kg		
標準巻掛本数	5	4	3		2

カウンタウエイト 25t、アウトリガ張出幅 6.8m
ブーム+12.0mフィックスジブ

単位:t

ブーム長さ(m) 作業半径(m)	40.4	45.4	50.5	55.6	60.0
9.0	43.1				
10.0	40.6				
11.0	37.0	32.8			
12.0	31.6	31.2	24.6		
14.0	23.9	24.2	22.4	20.0	
16.0	18.6	18.9	19.4	18.5	17.4
18.0	14.8	15.1	15.5	16.0	15.9
20.0	11.9	12.2	12.6	13.1	13.0
22.0	9.6	9.9	10.3	10.8	10.7
24.0	7.6	8.0	8.4	8.9	8.8
26.0	5.9	6.3	6.7	7.3	7.2
28.0	4.5	4.8	5.3	5.9	5.7
30.0	3.3	3.6	4.1	4.6	4.5
32.0		2.6	3.0	3.6	
θ (°)	55~ 83	56~ 83	60~ 83	63~ 83	67~ 83
標準フック	80t				
フック重量	1550kg		950kg		
標準巻掛本数	4	3		2	

カウンタウエイト 25t、アウトリガ張出幅 6.8m
ブーム+18.0mフィックスジブ

単位:t

ブーム長さ(m) 作業半径(m)	40.4	45.4	50.5	55.6	60.0
11.0	32.8				
12.0	31.4	28.5			
14.0	24.7	24.8	20.7	18.1	
16.0	19.4	19.4	19.0	16.7	15.8
18.0	15.5	15.6	16.1	15.5	14.7
20.0	12.6	12.6	13.1	13.4	13.2
22.0	10.3	10.3	10.8	11.0	10.9
24.0	8.4	8.5	8.9	9.2	9.0
26.0	6.7	6.8	7.3	7.6	7.4
28.0	5.2	5.3	5.8	6.1	5.9
30.0	4.0	4.1	4.6	4.9	4.7
32.0	3.0	3.0	3.5	3.8	
θ (°)	57~ 83	61~ 83	63~ 83	66~ 83	69~ 83
標準フック	35t				
フック重量	950kg				
標準巻掛本数	3		2		

PS+フィックスジブ

PS+ブーム+フィックスジブ(LFJ)作業半径-揚程図

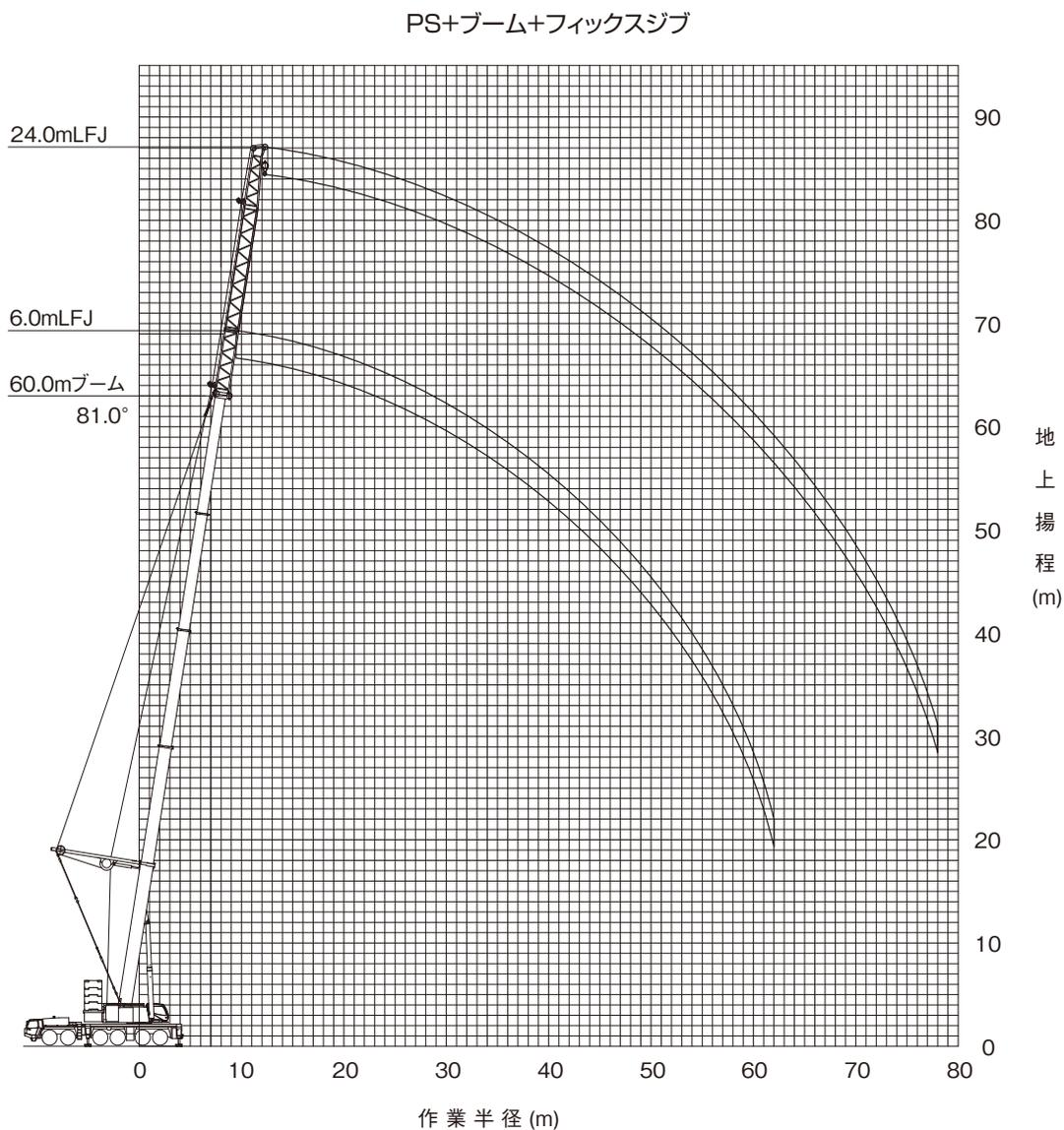

(注意)

- ◆ 上図はブームおよびジブのたわみを含んでいません。
- ◆ カウンタウエイト138t、アウトリガ張出幅8.5mの性能を図示しています。

PS+ブーム+フィックスジブ(LFJ)定格総荷重表

■ 定格総荷重表注意事項

◆性能設定のあるカウンタウエイトとアウトリガ張出幅の組合せを、下表に○印で示します。

アウトリガ張出幅 \ カウンタウエイト	138 t	118 t	98 t	78 t	58 t	47 t	25 t
8.5 m	○	○	○	○	○	○	○
8.0 m	/	○	○	○	○	○	○
6.8 m	/	/	/	○	○	○	○

◆定格総荷重は、つり具質量とフック質量(80トンフック: 1,550kg、35トンフック:950kg、12.2トンフック:440kg)を含んだ値を示します。

◆定格総荷重は、ブームとジブのたわみを含んだ実際の作業半径に基づいています。

◆各ブーム長さにおける各伸縮ブームの伸長状態(伸長割合%)は、下表のとおりです。

ブーム長さ	40.4 m	45.4 m	50.5 m	55.6 m	60.0 m
伸縮ブーム1	90	90	90	90	100
伸縮ブーム2	90	90	90	90	100
伸縮ブーム3	45	90	90	90	100
伸縮ブーム4	0	0	45	90	100

◆ブーム長さ40.4m未満での性能設定はありません。また、Bピン(ブーム固定ピン)を挿入していない状態では使用できません。

◆定格総荷重表中の標準巻掛本数より少ない本数で使用する場合、最大荷重の上限は下表のとおりです。

巻掛本数	4本	3本	2本	1本
最大荷重	47.4t	35.9t	24.1t	12.2t

◆定格総荷重は、アウトリガを水平堅土上に設置したときの値です。

◆定格総荷重表は、風による影響を含んでいません。瞬間最大風速が10m/s以上の風速では、クレーン作業を中止してください。

定格総荷重表中の線、および用語説明

◆太線より上側はクレーンの強度に、下側はクレーンの安定に基づいています。

◆「 θ° 」は、無負荷状態で作動可能なブーム起伏角度範囲を示します。

PS+フィックスジブ

カウンタウエイト 138t、アウトリガ張出幅 8.5m

PS+ブーム+6.0mフィックスジブ

単位:t

ブーム長さ(m) 作業半径(m)	40.4	45.4	50.5	55.6	60.0
9.0	58.6	51.2			
10.0	58.6	51.2	37.9		
11.0	58.6	51.2	36.5	30.3	
12.0	58.6	51.2	35.1	29.1	27.7
14.0	58.5	50.0	32.8	27.1	25.8
16.0	51.7	47.9	30.8	25.3	24.2
18.0	46.1	44.1	29.1	23.8	22.8
20.0	41.5	39.7	27.6	22.5	21.5
22.0	37.7	36.1	26.3	21.3	20.4
24.0	34.5	32.9	25.1	20.2	19.4
26.0	31.7	30.3	24.0	19.3	18.5
28.0	29.3	27.9	23.1	18.4	17.7
30.0	27.1	25.9	22.2	17.7	16.7
32.0	25.2	24.1	21.4	17.0	15.6
34.0	23.5	22.5	20.7	16.3	14.6
36.0	22.0	21.0	20.1	15.8	13.7
38.0	20.7	19.7	19.3	15.2	12.8
40.0	17.9	18.5	18.2	14.8	12.1
42.0	14.5	17.5	17.1	14.3	11.4
44.0	9.3	16.0	16.2	13.9	10.8
46.0		13.4	15.3	13.6	10.2
48.0		10.1	14.5	13.2	9.7
50.0			12.6	13.0	9.2
54.0			6.4	11.7	8.3
58.0				7.2	7.4
62.0					6.5
θ(°)	10~ 79	16~ 81	10~ 81	16~ 81	17~ 81
標準フック	80t		35t		
フック重量	1550kg		950kg		
標準巻掛本数	5	4	3		

カウンタウエイト 138t、アウトリガ張出幅 8.5m

PS+ブーム+12.0mフィックスジブ

単位:t

ブーム長さ(m) 作業半径(m)	40.4	45.4	50.5	55.6	60.0
10.0	47.4				
11.0	47.4	38.4			
12.0	46.8	38.4	29.6		
14.0	42.5	38.4	27.4	23.7	20.9
16.0	38.9	38.4	25.6	22.0	20.9
18.0	35.9	38.3	24.0	20.6	19.7
20.0	33.0	35.6	22.5	19.3	18.5
22.0	30.5	32.4	21.3	18.2	17.5
24.0	28.3	29.6	20.2	17.2	16.5
26.0	26.5	27.2	19.2	16.3	15.7
28.0	24.8	25.1	18.3	15.5	15.0
30.0	23.4	23.2	17.5	14.8	14.3
32.0	22.1	21.6	16.8	14.2	13.4
34.0	21.0	20.1	16.2	13.6	12.5
36.0	19.7	18.8	15.6	13.0	11.7
38.0	18.5	17.6	15.0	12.5	10.9
40.0	17.4	16.6	14.5	12.1	10.3
42.0	16.4	15.6	14.1	11.7	9.7
44.0	15.4	14.7	13.7	11.3	9.1
46.0	14.3	13.9	13.3	10.9	8.6
48.0	11.5	13.1	12.9	10.6	8.2
50.0	7.2	12.4	12.2	10.3	7.7
54.0		7.9	11.0	9.8	7.0
58.0			7.9	9.3	6.3
62.0				7.8	5.7
66.0					5.2
70.0					2.0
θ(°)	10~ 81	16~ 82	19~ 83	22~ 83	0~ 83
標準フック	80t		35t		
フック重量	1550kg		950kg		
標準巻掛本数	4	3	2		

カウンタウエイト 138t、アウトリガ張出幅 8.5m

PS+ブーム+18.0mフィックスジブ

単位:t

ブーム長さ(m) 作業半径(m)	40.4	45.4	50.5	55.6	60.0
11.0	33.3				
12.0	33.2	29.1			
14.0	31.1	29.1	22.8	18.0	
16.0	28.6	28.5	22.3	18.0	15.8
18.0	26.2	27.0	20.8	18.0	15.4
20.0	24.2	25.7	19.5	17.0	15.0
22.0	22.5	24.0	18.3	15.9	14.6
24.0	20.9	22.4	17.3	15.0	14.1
26.0	19.6	21.0	16.4	14.2	13.7
28.0	18.3	19.8	15.6	13.5	13.1
30.0	17.1	18.5	14.8	12.8	12.4
32.0	16.1	17.4	14.2	12.2	11.9
34.0	15.2	16.5	13.6	11.7	11.1
36.0	14.4	15.6	13.0	11.2	10.3
38.0	13.6	14.8	12.5	10.7	9.6
40.0	13.0	14.1	12.0	10.3	9.0
42.0	12.4	13.4	11.6	9.9	8.5
44.0	11.8	12.8	11.2	9.5	8.0
46.0	11.3	12.3	10.9	9.2	7.5
48.0	10.9	11.8	10.5	8.9	7.1
50.0	10.4	11.3	10.2	8.6	6.7
54.0	9.2	10.2	9.7	8.1	6.0
58.0		8.7	9.0	7.7	5.4
62.0			8.2	7.3	4.8
66.0			3.7	7.0	4.4
70.0				4.4	4.0
74.0					3.7
θ(°)	19~ 81	22~ 83	11~ 83	15~ 83	17~ 83
標準フック	35t				
フック重量	950kg				
標準巻掛本数	3	2			

カウンタウエイト 138t、アウトリガ張出幅 8.5m

PS+ブーム+24.0mフィックスジブ

単位:t

ブーム長さ(m) 作業半径(m)	40.4	45.4	50.5	55.6	60.0
12.0	23.7				
14.0	23.0	21.0			
16.0	21.6	21.0	16.8	13.2	
18.0	20.4	19.9	16.8	13.2	11.2
20.0	18.8	19.0	16.8	13.2	10.9
22.0	17.3	18.0	16.0	13.2	10.6
24.0	16.1	17.2	15.0	13.2	10.2
26.0	15.0	16.3	14.2	12.5	9.8
28.0	14.0	15.2	13.4	11.8	9.4
30.0	13.2	14.3	12.7	11.2	9.1
32.0	12.4	13.5	12.1	10.7	8.7
34.0	11.7	12.8	11.6	10.1	8.3
36.0	11.1	12.1	11.1	9.7	7.9
38.0	10.5	11.5	10.6	9.2	7.5
40.0	9.9	10.9	10.2	8.9	7.1
42.0	9.4	10.4	9.8	8.5	6.8
44.0	9.0	9.9	9.4	8.2	6.5
46.0	8.5	9.4	9.1	7.8	6.1
48.0	8.1	9.0	8.8	7.6	5.8
50.0	7.8	8.6	8.5	7.3	5.5
54.0	7.1	7.9	8.0	6.8	5.0
58.0	6.6	7.3	7.5	6.4	4.4
62.0	3.9	6.8	7.1	6.0	3.9
66.0		4.6	6.5	5.7	3.5
70.0			4.9	5.3	3.1
74.0				4.8	2.8
78.0					2.5
θ(°)	9~ 83	15~ 83	18~ 83	21~ 83	22~ 83
標準フック	35t				12.2t
フック重量	950kg				440kg
標準巻掛本数	2				1

カウンタウエイト 118t、アウトリガ張出幅 8.5m

PS+ブーム+6.0mフィックスジブ 単位:t

ブーム長さ(m) 作業半径(m)	40.4	45.4	50.5	55.6	60.0
8.0	58.6				
9.0	58.6	51.2			
10.0	58.6	51.2	37.9		
11.0	58.6	51.2	36.5	30.3	
12.0	58.6	51.2	35.1	29.1	27.7
14.0	58.5	50.0	32.8	27.1	25.8
16.0	51.7	47.9	30.8	25.3	24.2
18.0	46.1	44.1	29.1	23.8	22.8
20.0	41.5	39.7	27.6	22.5	21.5
22.0	37.7	36.1	26.3	21.3	20.4
24.0	34.5	32.9	25.1	20.2	19.4
26.0	31.7	30.3	24.0	19.3	18.5
28.0	29.3	27.9	23.1	18.4	17.7
30.0	27.1	25.9	22.2	17.7	16.7
32.0	25.2	24.1	21.4	17.0	15.6
34.0	23.5	22.5	20.7	16.3	14.6
36.0	21.5	21.0	20.1	15.8	13.7
38.0	19.6	19.7	19.3	15.2	12.8
40.0	17.9	18.4	18.2	14.8	12.1
42.0	14.5	16.9	17.1	14.3	11.4
44.0	9.3	15.5	16.2	13.9	10.8
46.0		13.4	14.9	13.6	10.2
48.0		10.1	13.8	13.2	9.7
50.0			12.6	13.0	9.2
54.0			6.4	11.4	8.3
58.0				7.2	7.4
62.0					6.5
θ(°)	10~ 81	16~ 81	10~ 81	16~ 81	17~ 81
標準フック	80t			35t	
フック重量	1550kg			950kg	
標準巻掛本数	5		4		

カウンタウエイト 118t、アウトリガ張出幅 8.5m

PS+ブーム+12.0mフィックスジブ 単位:t

ブーム長さ(m) 作業半径(m)	40.4	45.4	50.5	55.6	60.0
9.0	47.4				
10.0	47.4				
11.0	47.4	38.4			
12.0	46.8	38.4	29.6		
14.0	42.5	38.4	27.4	23.7	20.9
16.0	38.9	38.4	25.6	22.0	20.9
18.0	35.9	38.3	24.0	20.6	19.7
20.0	33.0	35.6	22.5	19.3	18.5
22.0	30.5	32.4	21.3	18.2	17.5
24.0	28.3	29.6	20.2	17.2	16.5
26.0	26.5	27.2	19.2	16.3	15.7
28.0	24.8	25.1	18.3	15.5	15.0
30.0	23.4	23.2	17.5	14.8	14.3
32.0	22.1	21.6	16.8	14.2	13.4
34.0	21.0	20.1	16.2	13.6	12.5
36.0	19.7	18.8	15.6	13.0	11.7
38.0	18.5	17.6	15.0	12.5	10.9
40.0	17.4	16.6	14.5	12.1	10.3
42.0	16.4	15.6	14.1	11.7	9.7
44.0	15.4	14.7	13.7	11.3	9.1
46.0	14.3	13.9	13.3	10.9	8.6
48.0	11.5	13.1	12.9	10.6	8.2
50.0	7.2	12.4	12.2	10.3	7.7
54.0		7.9	11.0	9.8	7.0
58.0			7.9	9.3	6.3
62.0				7.8	5.7
66.0					5.2
70.0					2.0
θ(°)	10~ 83	16~ 83	19~ 83	22~ 83	0~ 83
標準フック	80t			35t	
フック重量	1550kg			950kg	
標準巻掛本数	4		3		

カウンタウエイト 118t、アウトリガ張出幅 8.5m

PS+ブーム+18.0mフィックスジブ 単位:t

ブーム長さ(m) 作業半径(m)	40.4	45.4	50.5	55.6	60.0
11.0	33.3				
12.0	33.2	29.1			
14.0	31.1	29.1	22.8	18.0	
16.0	28.6	28.5	22.3	18.0	15.8
18.0	26.2	27.0	20.8	18.0	15.4
20.0	24.2	25.7	19.5	17.0	15.0
22.0	22.5	24.0	18.3	15.9	14.6
24.0	20.9	22.4	17.3	15.0	14.1
26.0	19.6	21.0	16.4	14.2	13.7
28.0	18.3	19.8	15.6	13.5	13.1
30.0	17.1	18.5	14.8	12.8	12.4
32.0	16.1	17.4	14.2	12.2	11.9
34.0	15.2	16.5	13.6	11.7	11.1
36.0	14.4	15.6	13.0	11.2	10.3
38.0	13.6	14.8	12.5	10.7	9.6
40.0	13.0	14.1	12.0	10.3	9.0
42.0	12.4	13.4	11.6	9.9	8.5
44.0	11.8	12.8	11.2	9.5	8.0
46.0	11.3	12.3	10.9	9.2	7.5
48.0	10.9	11.8	10.5	8.9	7.1
50.0	10.4	11.3	10.2	8.6	6.7
54.0	9.2	10.2	9.7	8.1	6.0
58.0		8.7	9.0	7.7	5.4
62.0			8.2	7.3	4.8
66.0			3.7	7.0	4.4
70.0				4.4	4.0
74.0					3.7
θ(°)	19~ 83	22~ 83	11~ 83	15~ 83	17~ 83
標準フック	35t				
フック重量	950kg				
標準巻掛本数	3			2	

カウンタウエイト 118t、アウトリガ張出幅 8.5m

PS+ブーム+24.0mフィックスジブ 単位:t

ブーム長さ(m) 作業半径(m)	40.4	45.4	50.5	55.6	60.0
12.0	23.7				
14.0	23.0	21.0			
16.0	21.6	21.0	16.8	13.2	
18.0	20.4	19.9	16.8	13.2	11.2
20.0	18.8	19.0	16.8	13.2	10.9
22.0	17.3	18.0	16.0	13.2	10.6
24.0	16.1	17.2	15.0	13.2	10.2
26.0	15.0	16.3	14.2	12.5	9.8
28.0	14.0	15.2	13.4	11.8	9.4
30.0	13.2	14.3	12.7	11.2	9.1
32.0	12.4	13.5	12.1	10.7	8.7
34.0	11.7	12.8	11.6	10.1	8.3
36.0	11.1	12.1	11.1	9.7	7.9
38.0	10.5	11.5	10.6	9.2	7.5
40.0	9.9	10.9	10.2	8.9	7.1
42.0	9.4	10.4	9.8	8.5	6.8
44.0	9.0	9.9	9.4	8.2	6.5
46.0	8.5	9.4	9.1	7.8	6.1
48.0	8.1	9.0	8.8	7.6	5.8
50.0	7.8	8.6	8.5	7.3	5.5
54.0	7.1	7.9	8.0	6.8	5.0
58.0	6.6	7.3	7.5	6.4	4.4
62.0	3.9	6.8	7.1	6.0	3.9
66.0		4.6	6.5	5.7	3.5
70.0			4.9	5.3	3.1
74.0				4.8	2.8
78.0					2.5
θ(°)	9~ 83	15~ 83	18~ 83	21~ 83	22~ 83
標準フック	35t				12.2t
フック重量	950kg				440kg
標準巻掛本数	2			1	

PS+フィックスジブ

カウンタウエイト 118t、アウトリガ張出幅 8.0m

PS+ブーム+6.0mフィックスジブ

単位:t

ブーム長さ(m) 作業半径(m)	40.4	45.4	50.5	55.6	60.0
8.0	58.6				
9.0	58.6	51.2			
10.0	58.6	51.2	37.9		
11.0	58.6	51.2	36.5	30.3	
12.0	58.6	51.2	35.1	29.1	27.7
14.0	58.5	50.0	32.8	27.1	25.8
16.0	51.7	47.9	30.8	25.3	24.2
18.0	46.1	44.1	29.1	23.8	22.8
20.0	41.5	39.7	27.6	22.5	21.5
22.0	37.7	36.1	26.3	21.3	20.4
24.0	34.5	32.9	25.1	20.2	19.4
26.0	31.7	30.3	24.0	19.3	18.5
28.0	29.3	27.9	23.1	18.4	17.7
30.0	27.1	25.9	22.2	17.7	16.7
32.0	25.2	24.1	21.4	17.0	15.6
34.0	23.1	22.5	20.7	16.3	14.6
36.0	20.9	21.0	20.1	15.8	13.7
38.0	19.0	19.5	19.3	15.2	12.8
40.0	17.4	17.8	18.2	14.8	12.1
42.0	14.5	16.4	17.0	14.3	11.4
44.0	9.3	15.0	15.6	13.9	10.8
46.0		13.4	14.4	13.6	10.2
48.0		10.1	13.3	13.2	9.7
50.0			12.3	12.8	9.2
54.0			6.4	11.0	8.3
58.0				7.2	7.4
62.0					6.5
θ(°)	10~ 81	16~ 81	10~ 81	16~ 81	17~ 81
標準フック	80t			35t	
フック重量	1550kg			950kg	
標準巻掛本数	5		4		

カウンタウエイト 118t、アウトリガ張出幅 8.0m

PS+ブーム+12.0mフィックスジブ

単位:t

ブーム長さ(m) 作業半径(m)	40.4	45.4	50.5	55.6	60.0
9.0	47.4				
10.0	47.4				
11.0	47.4	38.4			
12.0	46.8	38.4	29.6		
14.0	42.5	38.4	27.4	23.7	20.9
16.0	38.9	38.4	25.6	22.0	20.9
18.0	35.9	38.3	24.0	20.6	19.7
20.0	33.0	35.6	22.5	19.3	18.5
22.0	30.5	32.4	21.3	18.2	17.5
24.0	28.3	29.6	20.2	17.2	16.5
26.0	26.5	27.2	19.2	16.3	15.7
28.0	24.8	25.1	18.3	15.5	15.0
30.0	23.4	23.2	17.5	14.8	14.3
32.0	22.1	21.6	16.8	14.2	13.4
34.0	21.0	20.1	16.2	13.6	12.5
36.0	19.7	18.8	15.6	13.0	11.7
38.0	18.5	17.6	15.0	12.5	10.9
40.0	17.4	16.6	14.5	12.1	10.3
42.0	16.4	15.6	14.1	11.7	9.7
44.0	15.3	14.7	13.7	11.3	9.1
46.0	14.0	13.9	13.3	10.9	8.6
48.0	11.5	13.1	12.9	10.6	8.2
50.0	7.2	12.2	12.2	10.3	7.7
54.0		7.9	10.8	9.8	7.0
58.0			7.9	9.3	6.3
62.0				7.8	5.7
66.0					5.2
70.0					2.0
θ(°)	10~ 83	16~ 83	19~ 83	22~ 83	0~ 83
標準フック	80t			35t	
フック重量	1550kg			950kg	
標準巻掛本数	4		3		2

カウンタウエイト 118t、アウトリガ張出幅 8.0m

PS+ブーム+18.0mフィックスジブ

単位:t

ブーム長さ(m) 作業半径(m)	40.4	45.4	50.5	55.6	60.0
11.0	33.3				
12.0	33.2	29.1			
14.0	31.1	29.1	22.8	18.0	
16.0	28.6	28.5	22.3	18.0	15.8
18.0	26.2	27.0	20.8	18.0	15.4
20.0	24.2	25.7	19.5	17.0	15.0
22.0	22.5	24.0	18.3	15.9	14.6
24.0	20.9	22.4	17.3	15.0	14.1
26.0	19.6	21.0	16.4	14.2	13.7
28.0	18.3	19.8	15.6	13.5	13.1
30.0	17.1	18.5	14.8	12.8	12.4
32.0	16.1	17.4	14.2	12.2	11.9
34.0	15.2	16.5	13.6	11.7	11.1
36.0	14.4	15.6	13.0	11.2	10.3
38.0	13.6	14.8	12.5	10.7	9.6
40.0	13.0	14.1	12.0	10.3	9.0
42.0	12.4	13.4	11.6	9.9	8.5
44.0	11.8	12.8	11.2	9.5	8.0
46.0	11.3	12.3	10.9	9.2	7.5
48.0	10.9	11.8	10.5	8.9	7.1
50.0	10.4	11.3	10.2	8.6	6.7
54.0	9.2	10.2	9.7	8.1	6.0
58.0		8.7	9.0	7.7	5.4
62.0			8.1	7.3	4.8
66.0			3.7	7.0	4.4
70.0				4.4	4.0
74.0					3.7
θ(°)	19~ 83	22~ 83	11~ 83	15~ 83	17~ 83
標準フック	35t				
フック重量	950kg				
標準巻掛本数	3		2		

カウンタウエイト 118t、アウトリガ張出幅 8.0m

PS+ブーム+24.0mフィックスジブ

単位:t

ブーム長さ(m) 作業半径(m)	40.4	45.4	50.5	55.6	60.0
12.0	23.7				
14.0	23.0	21.0			
16.0	21.6	21.0	16.8	13.2	
18.0	20.4	19.9	16.8	13.2	11.2
20.0	18.8	19.0	16.8	13.2	10.9
22.0	17.3	18.0	16.0	13.2	10.6
24.0	16.1	17.2	15.0	13.2	10.2
26.0	15.0	16.3	14.2	12.5	9.8
28.0	14.0	15.2	13.4	11.8	9.4
30.0	13.2	14.3	12.7	11.2	9.1
32.0	12.4	13.5	12.1	10.7	8.7
34.0	11.7	12.8	11.6	10.1	8.3
36.0	11.1	12.1	11.1	9.7	7.9
38.0	10.5	11.5	10.6	9.2	7.5
40.0	9.9	10.9	10.2	8.9	7.1
42.0	9.4	10.4	9.8	8.5	6.8
44.0	9.0	9.9	9.4	8.2	6.5
46.0	8.5	9.4	9.1	7.8	6.1
48.0	8.1	9.0	8.8	7.6	5.8
50.0	7.8	8.6	8.5	7.3	5.5
54.0	7.1	7.9	8.0	6.8	5.0
58.0	6.6	7.3	7.5	6.4	4.4
62.0	3.9	6.8	7.1	6.0	3.9
66.0		4.6	6.5	5.7	3.5
70.0			4.9	5.3	3.1
74.0				4.8	2.8
78.0					2.5
θ(°)	9~ 83	15~ 83	18~ 83	21~ 83	22~ 83
標準フック	35t				12.2t
フック重量	950kg				440kg
標準巻掛本数	2			1	

カウンタウエイト 98t、アウトリガ張出幅 8.5m

PS+ブーム+6.0mフィックスジブ

単位:t

ブーム長さ(m) 作業半径(m)	40.4	45.4	50.5	55.6	60.0
8.0	58.6				
9.0	58.6	51.2			
10.0	58.6	51.2	37.9		
11.0	58.6	51.2	36.5	30.3	
12.0	58.6	51.2	35.1	29.1	27.7
14.0	58.5	50.0	32.8	27.1	25.8
16.0	51.7	47.9	30.8	25.3	24.2
18.0	46.1	44.1	29.1	23.8	22.8
20.0	41.5	39.7	27.6	22.5	21.5
22.0	37.7	36.1	26.3	21.3	20.4
24.0	34.5	32.9	25.1	20.2	19.4
26.0	30.4	30.3	24.0	19.3	18.5
28.0	27.0	27.5	23.1	18.4	17.7
30.0	24.1	24.6	22.2	17.7	16.7
32.0	21.6	22.1	21.4	17.0	15.6
34.0	19.4	19.9	20.6	16.3	14.6
36.0	17.6	18.0	18.7	15.8	13.7
38.0	15.9	16.4	17.0	15.2	12.8
40.0	14.4	14.9	15.5	14.8	12.1
42.0	13.1	13.5	14.2	14.3	11.4
44.0	9.3	12.4	13.0	13.5	10.8
46.0		11.2	11.9	12.4	10.2
48.0		10.1	10.9	11.4	9.7
50.0			9.8	10.4	9.2
54.0			6.4	8.6	8.3
58.0				7.1	7.2
62.0					5.8
θ (°)	10~ 81	16~ 81	10~ 81	16~ 81	17~ 81
標準フック	80t			35t	
フック重量	1550kg			950kg	
標準巻掛本数	5		4		

カウンタウエイト 98t、アウトリガ張出幅 8.5m

PS+ブーム+12.0mフィックスジブ

単位:t

ブーム長さ(m) 作業半径(m)	40.4	45.4	50.5	55.6	60.0
9.0	47.4				
10.0	47.4				
11.0	47.4	38.4			
12.0	46.8	38.4	29.6		
14.0	42.5	38.4	27.4	23.7	20.9
16.0	38.9	38.4	25.6	22.0	20.9
18.0	35.9	38.3	24.0	20.6	19.7
20.0	33.0	35.6	22.5	19.3	18.5
22.0	30.5	32.4	21.3	18.2	17.5
24.0	28.3	29.6	20.2	17.2	16.5
26.0	26.5	27.2	19.2	16.3	15.7
28.0	24.8	25.1	18.3	15.5	15.0
30.0	23.4	23.2	17.5	14.8	14.3
32.0	22.1	21.6	16.8	14.2	13.4
34.0	20.2	20.1	16.2	13.6	12.5
36.0	18.3	18.7	15.6	13.0	11.7
38.0	16.6	17.0	15.0	12.5	10.9
40.0	15.1	15.5	14.5	12.1	10.3
42.0	13.8	14.1	14.1	11.7	9.7
44.0	12.6	12.9	13.3	11.3	9.1
46.0	11.5	11.8	12.2	10.9	8.6
48.0	10.4	10.8	11.2	10.6	8.2
50.0	7.2	9.7	10.3	10.3	7.7
54.0		7.9	8.5	9.0	7.0
58.0			6.9	7.4	6.3
62.0				6.1	5.7
66.0					4.9
70.0					2.0
θ (°)	10~ 83	16~ 83	19~ 83	22~ 83	0~ 83
標準フック	80t			35t	
フック重量	1550kg			950kg	
標準巻掛本数	4		3		

カウンタウエイト 98t、アウトリガ張出幅 8.5m

PS+ブーム+18.0mフィックスジブ

単位:t

ブーム長さ(m) 作業半径(m)	40.4	45.4	50.5	55.6	60.0
11.0	33.3				
12.0	33.2	29.1			
14.0	31.1	29.1	22.8	18.0	
16.0	28.6	28.5	22.3	18.0	15.8
18.0	26.2	27.0	20.8	18.0	15.4
20.0	24.2	25.7	19.5	17.0	15.0
22.0	22.5	24.0	18.3	15.9	14.6
24.0	20.9	22.4	17.3	15.0	14.1
26.0	19.6	21.0	16.4	14.2	13.7
28.0	18.3	19.8	15.6	13.5	13.1
30.0	17.1	18.5	14.8	12.8	12.4
32.0	16.1	17.4	14.2	12.2	11.9
34.0	15.2	16.5	13.6	11.7	11.1
36.0	14.4	15.6	13.0	11.2	10.3
38.0	13.6	14.8	12.5	10.7	9.6
40.0	13.0	14.1	12.0	10.3	9.0
42.0	12.4	13.4	11.6	9.9	8.5
44.0	11.8	12.8	11.2	9.5	8.0
46.0	11.3	12.3	10.9	9.2	7.5
48.0	10.9	11.3	10.5	8.9	7.1
50.0	10.2	10.3	10.2	8.6	6.7
54.0	8.4	8.5	9.0	8.1	6.0
58.0		7.0	7.5	7.7	5.4
62.0			6.1	6.4	4.8
66.0			3.7	5.3	4.4
70.0				4.3	4.0
74.0					3.2
θ (°)	19~ 83	22~ 83	11~ 83	15~ 83	17~ 83
標準フック	35t				
フック重量	950kg				
標準巻掛本数	3			2	

カウンタウエイト 98t、アウトリガ張出幅 8.5m

PS+ブーム+24.0mフィックスジブ

単位:t

ブーム長さ(m) 作業半径(m)	40.4	45.4	50.5	55.6	60.0
12.0	23.7				
14.0	23.0	21.0			
16.0	21.6	21.0	16.8	13.2	
18.0	20.4	19.9	16.8	13.2	11.2
20.0	18.8	19.0	16.8	13.2	10.9
22.0	17.3	18.0	16.0	13.2	10.6
24.0	16.1	17.2	15.0	13.2	10.2
26.0	15.0	16.3	14.2	12.5	9.8
28.0	14.0	15.2	13.4	11.8	9.4
30.0	13.2	14.3	12.7	11.2	9.1
32.0	12.4	13.5	12.1	10.7	8.7
34.0	11.7	12.8	11.6	10.1	8.3
36.0	11.1	12.1	11.1	9.7	7.9
38.0	10.5	11.5	10.6	9.2	7.5
40.0	9.9	10.9	10.2	8.9	7.1
42.0	9.4	10.4	9.8	8.5	6.8
44.0	9.0	9.9	9.4	8.2	6.5
46.0	8.5	9.4	9.1	7.8	6.1
48.0	8.1	9.0	8.8	7.6	5.8
50.0	7.8	8.6	8.5	7.3	5.5
54.0	7.1	7.9	8.0	6.8	5.0
58.0	6.6	7.3	7.5	6.4	4.4
62.0	3.9	6.0	6.2	6.0	3.9
66.0		4.6	5.1	5.3	3.5
70.0			4.1	4.3	3.1
74.0				3.4	2.8
78.0					2.4
θ (°)	9~ 83	15~ 83	18~ 83	21~ 83	22~ 83
標準フック	35t				12.2t
フック重量	950kg				440kg
標準巻掛本数	2				1

PS+フィックスジブ

カウンタウエイト 98t、アウトリガ張出幅 8.0m

PS+ブーム+6.0mフィックスジブ

単位:t

ブーム長さ(m) 作業半径(m)	40.4	45.4	50.5	55.6	60.0
8.0	58.6				
9.0	58.6	51.2			
10.0	58.6	51.2	37.9		
11.0	58.6	51.2	36.5	30.3	
12.0	58.6	51.2	35.1	29.1	27.7
14.0	58.5	50.0	32.8	27.1	25.8
16.0	51.7	47.9	30.8	25.3	24.2
18.0	46.1	44.1	29.1	23.8	22.8
20.0	41.5	39.7	27.6	22.5	21.5
22.0	37.7	36.1	26.3	21.3	20.4
24.0	33.5	32.9	25.1	20.2	19.4
26.0	29.5	30.0	24.0	19.3	18.5
28.0	26.1	26.6	23.1	18.4	17.7
30.0	23.2	23.7	22.2	17.7	16.7
32.0	20.8	21.3	21.4	17.0	15.6
34.0	18.6	19.1	19.8	16.3	14.6
36.0	16.8	17.3	18.0	15.8	13.7
38.0	15.1	15.6	16.3	15.2	12.8
40.0	13.7	14.2	14.8	14.8	12.1
42.0	12.4	12.9	13.5	14.0	11.4
44.0	9.3	11.7	12.3	12.8	10.8
46.0		10.5	11.3	11.7	10.2
48.0		9.4	10.2	10.8	9.7
50.0			9.2	9.8	9.2
54.0			6.4	8.0	8.1
58.0				6.5	6.6
62.0					5.3
θ(°)	10~ 81	16~ 81	10~ 81	16~ 81	17~ 81
標準フック	80t			35t	
フック重量	1550kg			950kg	
標準巻掛本数	5		4		

カウンタウエイト 98t、アウトリガ張出幅 8.0m

PS+ブーム+12.0mフィックスジブ

単位:t

ブーム長さ(m) 作業半径(m)	40.4	45.4	50.5	55.6	60.0
9.0	47.4				
10.0	47.4				
11.0	47.4	38.4			
12.0	46.8	38.4	29.6		
14.0	42.5	38.4	27.4	23.7	20.9
16.0	38.9	38.4	25.6	22.0	20.9
18.0	35.9	38.3	24.0	20.6	19.7
20.0	33.0	35.6	22.5	19.3	18.5
22.0	30.5	32.4	21.3	18.2	17.5
24.0	28.3	29.6	20.2	17.2	16.5
26.0	26.5	27.2	19.2	16.3	15.7
28.0	24.8	25.1	18.3	15.5	15.0
30.0	23.4	23.2	17.5	14.8	14.3
32.0	21.6	21.6	16.8	14.2	13.4
34.0	19.4	19.8	16.2	13.6	12.5
36.0	17.5	17.9	15.6	13.0	11.7
38.0	15.9	16.2	15.0	12.5	10.9
40.0	14.4	14.8	14.5	12.1	10.3
42.0	13.1	13.4	13.9	11.7	9.7
44.0	11.9	12.3	12.7	11.3	9.1
46.0	10.8	11.2	11.6	10.9	8.6
48.0	9.7	10.1	10.6	10.6	8.2
50.0	7.2	9.1	9.6	10.2	7.7
54.0		7.3	7.9	8.4	7.0
58.0			6.4	6.9	6.3
62.0				5.6	5.5
66.0					4.4
70.0					2.0
θ(°)	10~ 83	16~ 83	19~ 83	22~ 83	0~ 83
標準フック	80t			35t	
フック重量	1550kg			950kg	
標準巻掛本数	4		3		

カウンタウエイト 98t、アウトリガ張出幅 8.0m

PS+ブーム+18.0mフィックスジブ

単位:t

ブーム長さ(m) 作業半径(m)	40.4	45.4	50.5	55.6	60.0
11.0	33.3				
12.0	33.2	29.1			
14.0	31.1	29.1	22.8	18.0	
16.0	28.6	28.5	22.3	18.0	15.8
18.0	26.2	27.0	20.8	18.0	15.4
20.0	24.2	25.7	19.5	17.0	15.0
22.0	22.5	24.0	18.3	15.9	14.6
24.0	20.9	22.4	17.3	15.0	14.1
26.0	19.6	21.0	16.4	14.2	13.7
28.0	18.3	19.8	15.6	13.5	13.1
30.0	17.1	18.5	14.8	12.8	12.4
32.0	16.1	17.4	14.2	12.2	11.9
34.0	15.2	16.5	13.6	11.7	11.1
36.0	14.4	15.6	13.0	11.2	10.3
38.0	13.6	14.8	12.5	10.7	9.6
40.0	13.0	14.1	12.0	10.3	9.0
42.0	12.4	13.4	11.6	9.9	8.5
44.0	11.8	12.7	11.2	9.5	8.0
46.0	11.3	11.7	10.9	9.2	7.5
48.0	10.6	10.7	10.5	8.9	7.1
50.0	9.5	9.7	10.2	8.6	6.7
54.0	7.8	7.9	8.4	8.1	6.0
58.0		6.4	6.9	7.2	5.4
62.0			5.6	5.9	4.8
66.0			3.7	4.8	4.4
70.0				3.8	3.7
74.0					2.8
θ(°)	19~ 83	22~ 83	11~ 83	15~ 83	17~ 83
標準フック	35t				
フック重量	950kg				
標準巻掛本数	3		2		

カウンタウエイト 98t、アウトリガ張出幅 8.0m

PS+ブーム+24.0mフィックスジブ

単位:t

ブーム長さ(m) 作業半径(m)	40.4	45.4	50.5	55.6	60.0
12.0	23.7				
14.0	23.0	21.0			
16.0	21.6	21.0	16.8	13.2	
18.0	20.4	19.9	16.8	13.2	11.2
20.0	18.8	19.0	16.8	13.2	10.9
22.0	17.3	18.0	16.0	13.2	10.6
24.0	16.1	17.2	15.0	13.2	10.2
26.0	15.0	16.3	14.2	12.5	9.8
28.0	14.0	15.2	13.4	11.8	9.4
30.0	13.2	14.3	12.7	11.2	9.1
32.0	12.4	13.5	12.1	10.7	8.7
34.0	11.7	12.8	11.6	10.1	8.3
36.0	11.1	12.1	11.1	9.7	7.9
38.0	10.5	11.5	10.6	9.2	7.5
40.0	9.9	10.9	10.2	8.9	7.1
42.0	9.4	10.4	9.8	8.5	6.8
44.0	9.0	9.9	9.4	8.2	6.5
46.0	8.5	9.4	9.1	7.8	6.1
48.0	8.1	9.0	8.8	7.6	5.8
50.0	7.8	8.6	8.5	7.3	5.5
54.0	7.1	7.9	8.0	6.8	5.0
58.0	6.6	6.8	7.0	6.4	4.4
62.0	3.9	5.5	5.7	6.0	3.9
66.0		4.3	4.6	4.8	3.5
70.0			3.6	3.8	3.1
74.0				2.9	2.8
78.0					2.0
θ(°)	9~ 83	15~ 83	18~ 83	21~ 83	22~ 83
標準フック	35t				12.2t
フック重量	950kg				440kg
標準巻掛本数	2			1	

カウンタウエイト 78t、アウトリガ張出幅 8.5m

PS+ブーム+6.0mフィックスジブ

単位:t

ブーム長さ(m) 作業半径(m)	40.4	45.4	50.5	55.6	60.0
8.0	58.6				
9.0	58.6	51.2			
10.0	58.6	51.2	37.9		
11.0	58.6	51.2	36.5	30.3	
12.0	58.6	51.2	35.1	29.1	27.7
14.0	58.5	50.0	32.8	27.1	25.8
16.0	51.7	47.9	30.8	25.3	24.2
18.0	45.0	44.1	29.1	23.8	22.8
20.0	38.1	38.6	27.6	22.5	21.5
22.0	32.7	33.2	26.3	21.3	20.4
24.0	28.4	28.9	25.1	20.2	19.4
26.0	24.8	25.3	24.0	19.3	18.5
28.0	21.8	22.4	23.1	18.4	17.7
30.0	19.3	19.9	20.6	17.7	16.7
32.0	17.2	17.7	18.4	17.0	15.6
34.0	15.3	15.8	16.5	16.3	14.6
36.0	13.7	14.2	14.9	15.3	13.7
38.0	12.2	12.7	13.4	13.9	12.8
40.0	10.8	11.4	12.1	12.6	12.1
42.0	9.5	10.1	10.9	11.4	11.4
44.0	8.4	8.9	9.8	10.4	10.5
46.0		7.9	8.7	9.3	9.4
48.0		6.9	7.7	8.3	8.4
50.0			6.8	7.4	7.5
54.0			5.3	5.9	5.9
58.0				4.5	4.6
62.0					3.4
θ (°)	10~ 81	16~ 81	10~ 81	16~ 81	17~ 81
標準フック	80t			35t	
フック重量	1550kg			950kg	
標準巻掛本数	5		4		3

カウンタウエイト 78t、アウトリガ張出幅 8.5m

PS+ブーム+12.0mフィックスジブ

単位:t

ブーム長さ(m) 作業半径(m)	40.4	45.4	50.5	55.6	60.0
9.0	47.4				
10.0	47.4				
11.0	47.4	38.4			
12.0	46.8	38.4	29.6		
14.0	42.5	38.4	27.4	23.7	20.9
16.0	38.9	38.4	25.6	22.0	20.9
18.0	35.9	38.3	24.0	20.6	19.7
20.0	33.0	35.6	22.5	19.3	18.5
22.0	30.5	32.4	21.3	18.2	17.5
24.0	28.3	29.6	20.2	17.2	16.5
26.0	25.7	26.0	19.2	16.3	15.7
28.0	22.7	23.0	18.3	15.5	15.0
30.0	20.1	20.5	17.5	14.8	14.3
32.0	18.0	18.3	16.8	14.2	13.4
34.0	16.1	16.4	16.2	13.6	12.5
36.0	14.4	14.8	15.2	13.0	11.7
38.0	13.0	13.3	13.7	12.5	10.9
40.0	11.7	12.0	12.4	12.1	10.3
42.0	10.4	10.8	11.3	11.7	9.7
44.0	9.3	9.7	10.2	10.7	9.1
46.0	8.2	8.6	9.1	9.7	8.6
48.0	7.2	7.6	8.1	8.7	8.2
50.0	6.4	6.7	7.2	7.8	7.7
54.0		5.2	5.7	6.2	6.1
58.0			4.3	4.9	4.8
62.0				3.7	3.6
66.0					2.6
70.0					1.7
θ (°)	10~ 83	16~ 83	19~ 83	22~ 83	0~ 83
標準フック	80t			35t	
フック重量	1550kg			950kg	
標準巻掛本数	4		3		2

カウンタウエイト 78t、アウトリガ張出幅 8.5m

PS+ブーム+18.0mフィックスジブ

単位:t

ブーム長さ(m) 作業半径(m)	40.4	45.4	50.5	55.6	60.0
11.0	33.3				
12.0	33.2	29.1			
14.0	31.1	29.1	22.8	18.0	
16.0	28.6	28.5	22.3	18.0	15.8
18.0	26.2	27.0	20.8	18.0	15.4
20.0	24.2	25.7	19.5	17.0	15.0
22.0	22.5	24.0	18.3	15.9	14.6
24.0	20.9	22.4	17.3	15.0	14.1
26.0	19.6	21.0	16.4	14.2	13.7
28.0	18.3	19.8	15.6	13.5	13.1
30.0	17.1	18.5	14.8	12.8	12.4
32.0	16.1	17.4	14.2	12.2	11.9
34.0	15.2	16.5	13.6	11.7	11.1
36.0	14.4	15.3	13.0	11.2	10.3
38.0	13.6	13.8	12.5	10.7	9.6
40.0	12.4	12.5	12.0	10.3	9.0
42.0	11.2	11.3	11.6	9.9	8.5
44.0	10.1	10.3	10.7	9.5	8.0
46.0	9.0	9.2	9.7	9.2	7.5
48.0	8.1	8.2	8.7	8.9	7.1
50.0	7.2	7.3	7.8	8.2	6.7
54.0	5.6	5.8	6.2	6.6	6.0
58.0		4.4	4.9	5.2	5.1
62.0			3.7	4.0	3.9
66.0			2.7	3.0	2.9
70.0				2.1	2.0
θ (°)	19~ 83	22~ 83	11~ 83	15~ 83	26~ 83
標準フック	35t			12.2t	
フック重量	950kg			440kg	
標準巻掛本数	3		2		

カウンタウエイト 78t、アウトリガ張出幅 8.5m

PS+ブーム+24.0mフィックスジブ

単位:t

ブーム長さ(m) 作業半径(m)	40.4	45.4	50.5	55.6	60.0
12.0	23.7				
14.0	23.0	21.0			
16.0	21.6	21.0	16.8	13.2	
18.0	20.4	19.9	16.8	13.2	11.2
20.0	18.8	19.0	16.8	13.2	10.9
22.0	17.3	18.0	16.0	13.2	10.6
24.0	16.1	17.2	15.0	13.2	10.2
26.0	15.0	16.3	14.2	12.5	9.8
28.0	14.0	15.2	13.4	11.8	9.4
30.0	13.2	14.3	12.7	11.2	9.1
32.0	12.4	13.5	12.1	10.7	8.7
34.0	11.7	12.8	11.6	10.1	8.3
36.0	11.1	12.1	11.1	9.7	7.9
38.0	10.5	11.5	10.6	9.2	7.5
40.0	9.9	10.9	10.2	8.9	7.1
42.0	9.4	10.4	9.8	8.5	6.8
44.0	9.0	9.9	9.4	8.2	6.5
46.0	8.5	9.4	9.1	7.8	6.1
48.0	8.1	8.6	8.8	7.6	5.8
50.0	7.6	7.7	8.0	7.3	5.5
54.0	6.0	6.1	6.4	6.6	5.0
58.0	4.7	4.7	5.0	5.2	4.4
62.0	3.5	3.6	3.9	4.1	3.9
66.0		2.6	2.8	3.1	2.9
70.0			1.9	2.2	2.0
θ (°)	9~ 83	15~ 83	18~ 83	29~ 83	35~ 83
標準フック	35t			12.2t	
フック重量	950kg			440kg	
標準巻掛本数	2		1		

PS+フィックスジブ

カウンタウエイト 78t、アウトリガ張出幅 8.0m

PS+ブーム+6.0mフィックスジブ 単位:t

ブーム長さ(m) 作業半径(m)	40.4	45.4	50.5	55.6	60.0
8.0	58.6				
9.0	58.6	51.2			
10.0	58.6	51.2	37.9		
11.0	58.6	51.2	36.5	30.3	
12.0	58.6	51.2	35.1	29.1	27.7
14.0	58.5	50.0	32.8	27.1	25.8
16.0	51.7	47.9	30.8	25.3	24.2
18.0	43.5	44.1	29.1	23.8	22.8
20.0	36.6	37.2	27.6	22.5	21.5
22.0	31.3	31.9	26.3	21.3	20.4
24.0	27.0	27.6	25.1	20.2	19.4
26.0	23.6	24.1	24.0	19.3	18.5
28.0	20.7	21.2	21.9	18.4	17.7
30.0	18.2	18.7	19.4	17.7	16.7
32.0	16.1	16.6	17.3	17.0	15.6
34.0	14.3	14.8	15.5	16.0	14.6
36.0	12.7	13.2	13.9	14.4	13.7
38.0	11.2	11.8	12.5	12.9	12.8
40.0	9.8	10.4	11.2	11.7	11.8
42.0	8.6	9.2	10.0	10.6	10.7
44.0	7.5	8.0	8.9	9.5	9.6
46.0		7.0	7.8	8.4	8.5
48.0		6.1	6.9	7.5	7.6
50.0			6.0	6.6	6.7
54.0			4.5	5.1	5.2
58.0				3.9	3.9
62.0					2.8
θ(°)	10~ 81	16~ 81	10~ 81	16~ 81	17~ 81
標準フック	80t			35t	
フック重量	1550kg			950kg	
標準巻掛本数	5		4		

カウンタウエイト 78t、アウトリガ張出幅 8.0m

PS+ブーム+12.0mフィックスジブ 単位:t

ブーム長さ(m) 作業半径(m)	40.4	45.4	50.5	55.6	60.0
9.0	47.4				
10.0	47.4				
11.0	47.4	38.4			
12.0	46.8	38.4	29.6		
14.0	42.5	38.4	27.4	23.7	20.9
16.0	38.9	38.4	25.6	22.0	20.9
18.0	35.9	38.3	24.0	20.6	19.7
20.0	33.0	35.6	22.5	19.3	18.5
22.0	30.5	32.4	21.3	18.2	17.5
24.0	27.9	28.3	20.2	17.2	16.5
26.0	24.4	24.8	19.2	16.3	15.7
28.0	21.5	21.9	18.3	15.5	15.0
30.0	19.0	19.4	17.5	14.8	14.3
32.0	16.9	17.3	16.8	14.2	13.4
34.0	15.1	15.4	15.9	13.6	12.5
36.0	13.5	13.8	14.2	13.0	11.7
38.0	12.1	12.4	12.8	12.5	10.9
40.0	10.8	11.1	11.6	12.0	10.3
42.0	9.5	9.9	10.4	10.9	9.7
44.0	8.4	8.8	9.3	9.9	9.1
46.0	7.3	7.7	8.3	8.8	8.6
48.0	6.4	6.8	7.3	7.9	7.8
50.0	5.6	5.9	6.5	7.0	6.9
54.0		4.4	4.9	5.5	5.4
58.0			3.7	4.2	4.1
62.0				3.1	3.0
66.0					2.0
θ(°)	10~ 83	16~ 83	19~ 83	22~ 83	23~ 83
標準フック	80t			35t	
フック重量	1550kg			950kg	
標準巻掛本数	4		3		

カウンタウエイト 78t、アウトリガ張出幅 8.0m

PS+ブーム+18.0mフィックスジブ 単位:t

ブーム長さ(m) 作業半径(m)	40.4	45.4	50.5	55.6	60.0
11.0	33.3				
12.0	33.2	29.1			
14.0	31.1	29.1	22.8	18.0	
16.0	28.6	28.5	22.3	18.0	15.8
18.0	26.2	27.0	20.8	18.0	15.4
20.0	24.2	25.7	19.5	17.0	15.0
22.0	22.5	24.0	18.3	15.9	14.6
24.0	20.9	22.4	17.3	15.0	14.1
26.0	19.6	21.0	16.4	14.2	13.7
28.0	18.3	19.8	15.6	13.5	13.1
30.0	17.1	18.5	14.8	12.8	12.4
32.0	16.1	17.4	14.2	12.2	11.9
34.0	15.2	16.0	13.6	11.7	11.1
36.0	14.2	14.3	13.0	11.2	10.3
38.0	12.8	12.9	12.5	10.7	9.6
40.0	11.5	11.6	12.0	10.3	9.0
42.0	10.4	10.5	10.9	9.9	8.5
44.0	9.2	9.4	9.9	9.5	8.0
46.0	8.2	8.4	8.9	9.2	7.5
48.0	7.3	7.4	7.9	8.3	7.1
50.0	6.4	6.6	7.0	7.4	6.7
54.0	4.9	5.0	5.5	5.8	5.7
58.0		3.8	4.2	4.5	4.4
62.0			3.1	3.4	3.3
66.0			2.1	2.4	2.3
70.0				1.6	1.5
θ(°)	19~ 83	22~ 83	11~ 83	15~ 83	26~ 83
標準フック	35t				
フック重量	950kg				
標準巻掛本数	3		2		

カウンタウエイト 78t、アウトリガ張出幅 8.0m

PS+ブーム+24.0mフィックスジブ 単位:t

ブーム長さ(m) 作業半径(m)	40.4	45.4	50.5	55.6	60.0
12.0	23.7				
14.0	23.0	21.0			
16.0	21.6	21.0	16.8	13.2	
18.0	20.4	19.9	16.8	13.2	11.2
20.0	18.8	19.0	16.8	13.2	10.9
22.0	17.3	18.0	16.0	13.2	10.6
24.0	16.1	17.2	15.0	13.2	10.2
26.0	15.0	16.3	14.2	12.5	9.8
28.0	14.0	15.2	13.4	11.8	9.4
30.0	13.2	14.3	12.7	11.2	9.1
32.0	12.4	13.5	12.1	10.7	8.7
34.0	11.7	12.8	11.6	10.1	8.3
36.0	11.1	12.1	11.1	9.7	7.9
38.0	10.5	11.5	10.6	9.2	7.5
40.0	9.9	10.9	10.2	8.9	7.1
42.0	9.4	10.4	9.8	8.5	6.8
44.0	9.0	9.8	9.4	8.2	6.5
46.0	8.5	8.8	9.0	7.8	6.1
48.0	7.7	7.8	8.1	7.6	5.8
50.0	6.9	6.9	7.2	7.3	5.5
54.0	5.3	5.4	5.7	5.9	5.0
58.0	4.0	4.1	4.3	4.6	4.4
62.0	2.9	2.9	3.2	3.5	3.3
66.0		2.0	2.2	2.5	2.3
70.0				1.6	
θ(°)	9~ 83	15~ 83	28~ 83	29~ 83	40~ 83
標準フック	35t				12.2t
フック重量	950kg				440kg
標準巻掛本数	2		1		

カウンタウエイト 78t、アウトリガ張出幅 6.8m

PS+ブーム+6.0mフィックスジブ 単位:t

ブーム長さ(m) 作業半径(m)	40.4	45.4	50.5	55.6	60.0
8.0	58.6				
9.0	58.6	51.2			
10.0	58.6	51.2	37.9		
11.0	58.6	51.2	36.5	30.3	
12.0	58.6	51.2	35.1	29.1	27.7
14.0	54.8	50.0	32.8	27.1	25.8
16.0	44.3	44.9	30.8	25.3	24.2
18.0	36.7	37.2	29.1	23.8	22.8
20.0	30.9	31.4	27.6	22.5	21.5
22.0	26.3	26.9	26.3	21.3	20.4
24.0	22.7	23.2	24.0	20.2	19.4
26.0	19.7	20.2	20.9	19.3	18.5
28.0	17.2	17.7	18.4	18.4	17.7
30.0	15.0	15.5	16.3	16.7	16.7
32.0	13.2	13.7	14.4	14.9	15.0
34.0	11.6	12.1	12.8	13.3	13.4
36.0	10.0	10.6	11.4	11.9	12.0
38.0	8.6	9.2	10.1	10.6	10.7
40.0	7.4	8.0	8.8	9.4	9.5
42.0	6.3	6.9	7.7	8.3	8.4
44.0	5.3	5.9	6.7	7.3	7.4
46.0		5.0	5.8	6.4	6.5
48.0		4.1	4.9	5.5	5.6
50.0			4.2	4.8	4.8
54.0			2.8	3.4	3.5
58.0				2.3	2.3
θ (°)	10~ 81	16~ 81	10~ 81	16~ 81	28~ 81
標準フック	80t			35t	
フック重量	1550kg			950kg	
標準巻掛本数	5	4	3		

カウンタウエイト 78t、アウトリガ張出幅 6.8m

PS+ブーム+12.0mフィックスジブ 単位:t

ブーム長さ(m) 作業半径(m)	40.4	45.4	50.5	55.6	60.0
9.0	47.4				
10.0	47.4				
11.0	47.4	38.4			
12.0	46.8	38.4	29.6		
14.0	42.5	38.4	27.4	23.7	20.9
16.0	38.9	38.4	25.6	22.0	20.9
18.0	35.9	38.1	24.0	20.6	19.7
20.0	31.8	32.2	22.5	19.3	18.5
22.0	27.2	27.6	21.3	18.2	17.5
24.0	23.6	23.9	20.2	17.2	16.5
26.0	20.5	20.9	19.2	16.3	15.7
28.0	18.0	18.4	18.3	15.5	15.0
30.0	15.8	16.2	16.6	14.8	14.3
32.0	14.0	14.3	14.8	14.2	13.4
34.0	12.4	12.7	13.1	13.6	12.5
36.0	11.0	11.3	11.7	12.2	11.7
38.0	9.6	10.0	10.5	11.0	10.9
40.0	8.3	8.7	9.2	9.8	9.8
42.0	7.2	7.6	8.1	8.7	8.6
44.0	6.2	6.6	7.1	7.7	7.6
46.0	5.3	5.6	6.2	6.7	6.7
48.0	4.4	4.8	5.3	5.9	5.8
50.0	3.7	4.0	4.6	5.1	5.0
54.0		2.7	3.2	3.7	3.7
58.0			2.1	2.6	2.5
62.0				1.6	1.5
θ (°)	10~ 83	16~ 83	19~ 83	22~ 83	31~ 83
標準フック	80t			35t	
フック重量	1550kg			950kg	
標準巻掛本数	4	3	2		

カウンタウエイト 78t、アウトリガ張出幅 6.8m

PS+ブーム+18.0mフィックスジブ 単位:t

ブーム長さ(m) 作業半径(m)	40.4	45.4	50.5	55.6	60.0
11.0	33.3				
12.0	33.2	29.1			
14.0	31.1	29.1	22.8	18.0	
16.0	28.6	28.5	22.3	18.0	15.8
18.0	26.2	27.0	20.8	18.0	15.4
20.0	24.2	25.7	19.5	17.0	15.0
22.0	22.5	24.0	18.3	15.9	14.6
24.0	20.9	22.4	17.3	15.0	14.1
26.0	19.6	21.0	16.4	14.2	13.7
28.0	18.3	18.9	15.6	13.5	13.1
30.0	16.6	16.7	14.8	12.8	12.4
32.0	14.7	14.9	14.2	12.2	11.9
34.0	13.1	13.2	13.6	11.7	11.1
36.0	11.7	11.8	12.3	11.2	10.3
38.0	10.4	10.6	11.0	10.7	9.6
40.0	9.2	9.3	9.9	10.1	9.0
42.0	8.0	8.2	8.7	9.1	8.5
44.0	7.0	7.2	7.7	8.0	7.9
46.0	6.1	6.3	6.8	7.1	7.0
48.0	5.3	5.4	5.9	6.2	6.1
50.0	4.5	4.6	5.1	5.5	5.3
54.0	3.1	3.3	3.8	4.1	4.0
58.0		2.2	2.6	2.9	2.8
62.0			1.6	1.9	1.8
θ (°)	19~ 83	22~ 83	24~ 83	33~ 83	38~ 83
標準フック	35t				
フック重量	950kg				
標準巻掛本数	3	2			

カウンタウエイト 78t、アウトリガ張出幅 6.8m

PS+ブーム+24.0mフィックスジブ 単位:t

ブーム長さ(m) 作業半径(m)	40.4	45.4	50.5	55.6	60.0
12.0	23.7				
14.0	23.0	21.0			
16.0	21.6	21.0	16.8	13.2	
18.0	20.4	19.9	16.8	13.2	11.2
20.0	18.8	19.0	16.8	13.2	10.9
22.0	17.3	18.0	16.0	13.2	10.6
24.0	16.1	17.2	15.0	13.2	10.2
26.0	15.0	16.3	14.2	12.5	9.8
28.0	14.0	15.2	13.4	11.8	9.4
30.0	13.2	14.3	12.7	11.2	9.1
32.0	12.4	13.5	12.1	10.7	8.7
34.0	11.7	12.8	11.6	10.1	8.3
36.0	11.1	12.1	11.1	9.7	7.9
38.0	10.5	10.9	10.6	9.2	7.5
40.0	9.7	9.7	10.0	8.9	7.1
42.0	8.5	8.6	8.9	8.5	6.8
44.0	7.5	7.6	7.8	8.1	6.5
46.0	6.6	6.6	6.9	7.1	6.1
48.0	5.7	5.8	6.1	6.3	5.8
50.0	4.9	5.0	5.3	5.5	5.3
54.0	3.6	3.6	3.9	4.1	4.0
58.0	2.4	2.5	2.7	3.0	2.8
62.0		1.5	1.7	2.0	1.8
θ (°)	24~ 83	26~ 83	34~ 83	40~ 83	44~ 83
標準フック	35t				12.2t
フック重量	950kg				440kg
標準巻掛本数	2				1

PS+フィックスジブ

カウンタウエイト 58t、アウトリガ張出幅 8.5m

PS+ブーム+6.0mフィックスジブ

単位:t

ブーム長さ(m) 作業半径(m)	40.4	45.4	50.5	55.6	60.0
8.0	58.6				
9.0	58.6	51.2			
10.0	58.6	51.2	37.9		
11.0	58.6	51.2	36.5	30.3	
12.0	58.6	51.2	35.1	29.1	27.7
14.0	54.5	50.0	32.8	27.1	25.8
16.0	43.8	44.5	30.8	25.3	24.2
18.0	36.1	36.7	29.1	23.8	22.8
20.0	30.3	30.9	27.6	22.5	21.5
22.0	25.8	26.4	26.3	21.3	20.4
24.0	22.1	22.6	23.4	20.2	19.4
26.0	19.0	19.6	20.3	19.3	18.5
28.0	16.5	17.0	17.7	18.2	17.7
30.0	14.3	14.8	15.6	16.1	16.2
32.0	12.5	13.0	13.7	14.2	14.3
34.0	10.9	11.4	12.1	12.6	12.7
36.0	9.3	9.9	10.7	11.2	11.3
38.0	7.9	8.5	9.4	9.9	10.1
40.0	6.7	7.3	8.1	8.7	8.9
42.0	5.6	6.2	7.0	7.6	7.7
44.0	4.6	5.2	6.0	6.6	6.7
46.0		4.3	5.1	5.7	5.8
48.0		3.5	4.3	4.9	5.0
50.0			3.5	4.1	4.2
54.0				2.8	2.9
58.0				1.7	1.8
θ(°)	10~ 81	16~ 81	26~ 81	16~ 81	28~ 81
標準フック	80t		35t		
フック重量	1550kg		950kg		
標準巻掛本数	5	4	3		

カウンタウエイト 58t、アウトリガ張出幅 8.5m

PS+ブーム+12.0mフィックスジブ

単位:t

ブーム長さ(m) 作業半径(m)	40.4	45.4	50.5	55.6	60.0
9.0	47.4				
10.0	47.4				
11.0	47.4	38.4			
12.0	46.8	38.4	29.6		
14.0	42.5	38.4	27.4	23.7	20.9
16.0	38.9	38.4	25.6	22.0	20.9
18.0	35.9	37.6	24.0	20.6	19.7
20.0	31.3	31.7	22.5	19.3	18.5
22.0	26.7	27.1	21.3	18.2	17.5
24.0	23.0	23.4	20.2	17.2	16.5
26.0	19.9	20.3	19.2	16.3	15.7
28.0	17.3	17.7	18.2	15.5	15.0
30.0	15.2	15.5	16.0	14.8	14.3
32.0	13.3	13.7	14.1	14.2	13.4
34.0	11.7	12.0	12.5	13.0	12.5
36.0	10.3	10.6	11.1	11.6	11.5
38.0	8.9	9.3	9.8	10.3	10.2
40.0	7.6	8.0	8.6	9.2	9.1
42.0	6.5	6.9	7.5	8.1	8.0
44.0	5.5	5.9	6.5	7.0	7.0
46.0	4.6	5.0	5.5	6.1	6.0
48.0	3.8	4.2	4.7	5.3	5.2
50.0	3.1	3.4	4.0	4.5	4.4
54.0			2.6	3.2	3.1
58.0			1.5	2.0	2.0
θ(°)	10~ 83	28~ 83	19~ 83	30~ 83	37~ 83
標準フック	80t		35t		
フック重量	1550kg		950kg		
標準巻掛本数	4	3	2		

カウンタウエイト 58t、アウトリガ張出幅 8.5m

PS+ブーム+18.0mフィックスジブ

単位:t

ブーム長さ(m) 作業半径(m)	40.4	45.4	50.5	55.6	60.0
11.0	33.3				
12.0	33.2	29.1			
14.0	31.1	29.1	22.8	18.0	
16.0	28.6	28.5	22.3	18.0	15.8
18.0	26.2	27.0	20.8	18.0	15.4
20.0	24.2	25.7	19.5	17.0	15.0
22.0	22.5	24.0	18.3	15.9	14.6
24.0	20.9	22.4	17.3	15.0	14.1
26.0	19.6	20.9	16.4	14.2	13.7
28.0	18.1	18.3	15.6	13.5	13.1
30.0	16.0	16.1	14.8	12.8	12.4
32.0	14.1	14.2	14.2	12.2	11.9
34.0	12.5	12.6	13.0	11.7	11.1
36.0	11.0	11.2	11.6	11.2	10.3
38.0	9.8	9.9	10.4	10.6	9.6
40.0	8.5	8.7	9.2	9.5	9.0
42.0	7.4	7.6	8.1	8.4	8.3
44.0	6.4	6.6	7.1	7.4	7.3
46.0	5.5	5.6	6.2	6.5	6.4
48.0	4.7	4.8	5.3	5.7	5.5
50.0	3.9	4.1	4.6	4.9	4.8
54.0	2.6	2.7	3.2	3.6	3.4
58.0		1.6	2.1	2.4	2.3
θ(°)	19~ 83	22~ 83	32~ 83	39~ 83	43~ 83
標準フック	35t				
フック重量	950kg				
標準巻掛本数	3	2			

カウンタウエイト 58t、アウトリガ張出幅 8.5m

PS+ブーム+24.0mフィックスジブ

単位:t

ブーム長さ(m) 作業半径(m)	40.4	45.4	50.5	55.6	60.0
12.0	23.7				
14.0	23.0	21.0			
16.0	21.6	21.0	16.8	13.2	
18.0	20.4	19.9	16.8	13.2	11.2
20.0	18.8	19.0	16.8	13.2	10.9
22.0	17.3	18.0	16.0	13.2	10.6
24.0	16.1	17.2	15.0	13.2	10.2
26.0	15.0	16.3	14.2	12.5	9.8
28.0	14.0	15.2	13.4	11.8	9.4
30.0	13.2	14.3	12.7	11.2	9.1
32.0	12.4	13.5	12.1	10.7	8.7
34.0	11.7	12.8	11.6	10.1	8.3
36.0	11.1	11.5	11.1	9.7	7.9
38.0	10.2	10.3	10.5	9.2	7.5
40.0	9.1	9.1	9.4	8.9	7.1
42.0	7.9	8.0	8.3	8.5	6.8
44.0	6.9	7.0	7.3	7.5	6.5
46.0	6.0	6.0	6.3	6.6	6.1
48.0	5.1	5.2	5.5	5.7	5.5
50.0	4.4	4.4	4.7	5.0	4.8
54.0	3.0	3.1	3.4	3.6	3.4
58.0	1.9	1.9	2.2	2.5	2.3
62.0				1.5	
θ(°)	24~ 83	33~ 83	40~ 83	40~ 83	48~ 83
標準フック	35t				12.2t
フック重量	950kg				440kg
標準巻掛本数	2				1

カウンタウエイト 58t、アウトリガ張出幅 8.0m

PS+ブーム+6.0mフィックスジブ 単位:t

ブーム長さ(m) 作業半径(m)	40.4	45.4	50.5	55.6	60.0
8.0	58.6				
9.0	58.6	51.2			
10.0	58.6	51.2	37.9		
11.0	58.6	51.2	36.5	30.3	
12.0	58.6	51.2	35.1	29.1	27.7
14.0	52.2	50.0	32.8	27.1	25.8
16.0	41.6	42.3	30.8	25.3	24.2
18.0	34.1	34.7	29.1	23.8	22.8
20.0	28.4	29.0	27.6	22.5	21.5
22.0	24.0	24.6	25.3	21.3	20.4
24.0	20.5	21.0	21.8	20.2	19.4
26.0	17.6	18.1	18.9	19.3	18.5
28.0	15.2	15.7	16.4	16.9	17.1
30.0	13.1	13.7	14.4	14.9	15.0
32.0	11.4	11.9	12.6	13.1	13.3
34.0	9.7	10.4	11.1	11.6	11.7
36.0	8.3	8.9	9.7	10.3	10.4
38.0	6.9	7.5	8.4	9.0	9.2
40.0	5.8	6.4	7.2	7.8	8.0
42.0	4.7	5.3	6.2	6.8	6.9
44.0	3.8	4.4	5.2	5.8	5.9
46.0		3.5	4.3	4.9	5.1
48.0		2.8	3.6	4.2	4.3
50.0			2.8	3.4	3.5
54.0				2.2	2.3
$\theta(^{\circ})$	10~ 81	16~ 81	26~ 81	27~ 81	35~ 81
標準フック	80t		35t		
フック重量	1550kg		950kg		
標準巻掛本数	5	4	3		

カウンタウエイト 58t、アウトリガ張出幅 8.0m

PS+ブーム+12.0mフィックスジブ 単位:t

ブーム長さ(m) 作業半径(m)	40.4	45.4	50.5	55.6	60.0
9.0	47.4				
10.0	47.4				
11.0	47.4	38.4			
12.0	46.8	38.4	29.6		
14.0	42.5	38.4	27.4	23.7	20.9
16.0	38.9	38.4	25.6	22.0	20.9
18.0	35.1	35.6	24.0	20.6	19.7
20.0	29.4	29.8	22.5	19.3	18.5
22.0	24.9	25.3	21.3	18.2	17.5
24.0	21.4	21.8	20.2	17.2	16.5
26.0	18.5	18.8	19.2	16.3	15.7
28.0	16.0	16.4	16.9	15.5	15.0
30.0	14.0	14.3	14.8	14.8	14.3
32.0	12.2	12.6	13.0	13.5	13.4
34.0	10.7	11.0	11.5	12.0	11.9
36.0	9.2	9.7	10.1	10.6	10.6
38.0	7.9	8.3	8.9	9.4	9.4
40.0	6.7	7.1	7.7	8.3	8.2
42.0	5.7	6.1	6.6	7.2	7.1
44.0	4.7	5.1	5.6	6.2	6.1
46.0	3.9	4.2	4.8	5.3	5.3
48.0	3.1	3.5	4.0	4.5	4.5
50.0	2.4	2.7	3.3	3.8	3.7
54.0			2.0	2.5	2.5
58.0				1.5	
$\theta(^{\circ})$	10~ 83	28~ 83	29~ 83	30~ 83	42~ 83
標準フック	80t		35t		
フック重量	1550kg		950kg		
標準巻掛本数	4	3	2		

カウンタウエイト 58t、アウトリガ張出幅 8.0m

PS+ブーム+18.0mフィックスジブ 単位:t

ブーム長さ(m) 作業半径(m)	40.4	45.4	50.5	55.6	60.0
11.0	33.3				
12.0	33.2	29.1			
14.0	31.1	29.1	22.8	18.0	
16.0	28.6	28.5	22.3	18.0	15.8
18.0	26.2	27.0	20.8	18.0	15.4
20.0	24.2	25.7	19.5	17.0	15.0
22.0	22.5	24.0	18.3	15.9	14.6
24.0	20.9	22.4	17.3	15.0	14.1
26.0	19.3	19.4	16.4	14.2	13.7
28.0	16.8	17.0	15.6	13.5	13.1
30.0	14.8	14.9	14.8	12.8	12.4
32.0	13.0	13.1	13.6	12.2	11.9
34.0	11.4	11.6	12.0	11.7	11.1
36.0	10.1	10.2	10.7	11.0	10.3
38.0	8.8	9.0	9.5	9.8	9.6
40.0	7.6	7.8	8.3	8.7	8.5
42.0	6.5	6.7	7.2	7.6	7.4
44.0	5.6	5.7	6.3	6.6	6.5
46.0	4.7	4.9	5.4	5.7	5.6
48.0	3.9	4.1	4.6	4.9	4.8
50.0	3.2	3.4	3.9	4.2	4.1
54.0		2.1	2.6	2.9	2.8
58.0			1.5	1.8	1.7
$\theta(^{\circ})$	30~ 83	31~ 83	32~ 83	39~ 83	43~ 83
標準フック	35t				
フック重量	950kg				
標準巻掛本数	3		2		

カウンタウエイト 58t、アウトリガ張出幅 8.0m

PS+ブーム+24.0mフィックスジブ 単位:t

ブーム長さ(m) 作業半径(m)	40.4	45.4	50.5	55.6	60.0
12.0	23.7				
14.0	23.0	21.0			
16.0	21.6	21.0	16.8	13.2	
18.0	20.4	19.9	16.8	13.2	11.2
20.0	18.8	19.0	16.8	13.2	10.9
22.0	17.3	18.0	16.0	13.2	10.6
24.0	16.1	17.2	15.0	13.2	10.2
26.0	15.0	16.3	14.2	12.5	9.8
28.0	14.0	15.2	13.4	11.8	9.4
30.0	13.2	14.3	12.7	11.2	9.1
32.0	12.4	13.5	12.1	10.7	8.7
34.0	11.7	12.0	11.6	10.1	8.3
36.0	10.6	10.6	10.8	9.7	7.9
38.0	9.4	9.4	9.6	9.2	7.5
40.0	8.1	8.2	8.5	8.7	7.1
42.0	7.1	7.1	7.4	7.6	6.8
44.0	6.1	6.1	6.4	6.7	6.5
46.0	5.2	5.3	5.5	5.8	5.6
48.0	4.4	4.5	4.7	5.0	4.8
50.0	3.7	3.7	4.0	4.2	4.1
54.0	2.4	2.4	2.7	3.0	2.8
58.0			1.6	1.9	1.7
$\theta(^{\circ})$	32~ 83	39~ 83	40~ 83	45~ 83	48~ 83
標準フック	35t				12.2t
フック重量	950kg				440kg
標準巻掛本数	2		1		

PS+フィックスジブ

カウンタウエイト 58t、アウトリガ張出幅 6.8m

PS+ブーム+6.0mフィックスジブ

単位:t

ブーム長さ(m) 作業半径(m)	40.4	45.4	50.5	55.6	60.0
8.0	58.6				
9.0	58.6	51.2			
10.0	58.6	51.2	37.9		
11.0	58.6	51.2	36.5	30.3	
12.0	55.9	51.2	35.1	29.1	27.7
14.0	43.2	43.9	32.8	27.1	25.8
16.0	34.6	35.2	30.8	25.3	24.2
18.0	28.3	28.9	29.1	23.8	22.8
20.0	23.5	24.1	24.9	22.5	21.5
22.0	19.8	20.3	21.1	21.3	20.4
24.0	16.8	17.3	18.0	18.5	18.7
26.0	14.3	14.8	15.5	16.0	16.2
28.0	12.2	12.7	13.4	13.9	14.1
30.0	10.4	11.0	11.7	12.1	12.3
32.0	8.6	9.3	10.1	10.6	10.7
34.0	7.2	7.8	8.6	9.3	9.4
36.0	5.8	6.5	7.3	7.9	8.1
38.0	4.7	5.3	6.1	6.7	6.9
40.0	3.7	4.3	5.1	5.7	5.8
42.0	2.8	3.3	4.2	4.8	4.9
44.0		2.5	3.3	3.9	4.0
46.0			2.6	3.2	3.3
48.0				2.5	2.6
50.0				1.8	1.9
θ(°)	21~ 81	29~ 81	34~ 81	35~ 81	41~ 81
標準フック	80t			35t	
フック重量	1550kg			950kg	
標準巻掛本数	5		4		

カウンタウエイト 58t、アウトリガ張出幅 6.8m

PS+ブーム+12.0mフィックスジブ

単位:t

ブーム長さ(m) 作業半径(m)	40.4	45.4	50.5	55.6	60.0
9.0	47.4				
10.0	47.4				
11.0	47.4	38.4			
12.0	46.8	38.4	29.6		
14.0	42.5	38.4	27.4	23.7	20.9
16.0	35.6	36.1	25.6	22.0	20.9
18.0	29.3	29.7	24.0	20.6	19.7
20.0	24.4	24.9	22.5	19.3	18.5
22.0	20.7	21.1	21.3	18.2	17.5
24.0	17.6	18.0	18.5	17.2	16.5
26.0	15.1	15.5	15.9	16.3	15.7
28.0	13.0	13.4	13.8	14.3	14.3
30.0	11.2	11.6	12.0	12.5	12.5
32.0	9.6	10.1	10.5	11.0	10.9
34.0	8.1	8.5	9.1	9.6	9.6
36.0	6.8	7.2	7.8	8.4	8.3
38.0	5.6	6.0	6.6	7.2	7.1
40.0	4.6	5.0	5.5	6.1	6.0
42.0	3.7	4.1	4.6	5.2	5.1
44.0	2.8	3.2	3.7	4.3	4.2
46.0		2.4	3.0	3.5	3.5
48.0			2.3	2.8	2.8
50.0			1.6	2.2	2.1
θ(°)	31~ 83	36~ 83	36~ 83	43~ 83	47~ 83
標準フック	80t			35t	
フック重量	1550kg			950kg	
標準巻掛本数	4		3		2

カウンタウエイト 58t、アウトリガ張出幅 6.8m

PS+ブーム+18.0mフィックスジブ

単位:t

ブーム長さ(m) 作業半径(m)	40.4	45.4	50.5	55.6	60.0
11.0	33.3				
12.0	33.2	29.1			
14.0	31.1	29.1	22.8	18.0	
16.0	28.6	28.5	22.3	18.0	15.8
18.0	26.2	27.0	20.8	18.0	15.4
20.0	24.2	25.5	19.5	17.0	15.0
22.0	21.5	21.6	18.3	15.9	14.6
24.0	18.4	18.6	17.3	15.0	14.1
26.0	15.9	16.0	16.4	14.2	13.7
28.0	13.8	13.9	14.4	13.5	13.1
30.0	12.0	12.1	12.6	12.8	12.4
32.0	10.5	10.6	11.0	11.3	11.2
34.0	9.0	9.2	9.7	10.0	9.8
36.0	7.7	7.9	8.4	8.7	8.6
38.0	6.5	6.7	7.2	7.6	7.4
40.0	5.5	5.6	6.2	6.5	6.4
42.0	4.5	4.7	5.2	5.5	5.4
44.0	3.7	3.8	4.3	4.7	4.5
46.0	2.9	3.1	3.6	3.9	3.8
48.0		2.4	2.9	3.2	3.1
50.0		1.7	2.2	2.5	2.4
θ(°)	37~ 83	38~ 83	44~ 83	48~ 83	52~ 83
標準フック	35t				
フック重量	950kg				
標準巻掛本数	3			2	

カウンタウエイト 58t、アウトリガ張出幅 6.8m

PS+ブーム+24.0mフィックスジブ

単位:t

ブーム長さ(m) 作業半径(m)	40.4	45.4	50.5	55.6	60.0
12.0	23.7				
14.0	23.0	21.0			
16.0	21.6	21.0	16.8	13.2	
18.0	20.4	19.9	16.8	13.2	11.2
20.0	18.8	19.0	16.8	13.2	10.9
22.0	17.3	18.0	16.0	13.2	10.6
24.0	16.1	17.2	15.0	13.2	10.2
26.0	15.0	16.3	14.2	12.5	9.8
28.0	14.0	14.3	13.4	11.8	9.4
30.0	12.5	12.5	12.7	11.2	9.1
32.0	10.9	11.0	11.2	10.7	8.7
34.0	9.5	9.6	9.8	10.0	8.3
36.0	8.2	8.3	8.6	8.8	7.9
38.0	7.0	7.1	7.4	7.6	7.4
40.0	6.0	6.0	6.3	6.5	6.4
42.0	5.0	5.1	5.4	5.6	5.4
44.0	4.1	4.2	4.5	4.7	4.5
46.0	3.4	3.4	3.7	3.9	3.8
48.0	2.7	2.7	3.0	3.2	3.1
50.0	2.0	2.1	2.4	2.6	2.4
θ(°)	39~ 83	44~ 83	49~ 83	53~ 83	56~ 83
標準フック	35t				12.2t
フック重量	950kg				440kg
標準巻掛本数	2				1

カウンタウエイト 47t、アウトリガ張出幅 8.5m

PS+ブーム+6.0mフィックスジブ

単位:t

ブーム長さ(m) 作業半径(m)	40.4	45.4	50.5	55.6	60.0
8.0	58.6				
9.0	58.6	51.2			
10.0	58.6	51.2	37.9		
11.0	58.6	51.2	36.5	30.3	
12.0	58.6	51.2	35.1	29.1	27.7
14.0	47.9	48.5	32.8	27.1	25.8
16.0	38.3	38.9	30.8	25.3	24.2
18.0	31.3	31.9	29.1	23.8	22.8
20.0	25.9	26.5	27.3	22.5	21.5
22.0	21.7	22.3	23.0	21.3	20.4
24.0	18.3	18.9	19.7	20.2	19.4
26.0	15.6	16.2	16.9	17.4	17.6
28.0	13.4	13.9	14.6	15.1	15.3
30.0	11.4	12.0	12.7	13.2	13.3
32.0	9.7	10.3	11.0	11.5	11.7
34.0	8.1	8.7	9.6	10.1	10.2
36.0	6.7	7.3	8.2	8.8	9.0
38.0	5.5	6.1	6.9	7.6	7.7
40.0	4.4	5.0	5.8	6.4	6.6
42.0	3.4	4.0	4.8	5.4	5.6
44.0	2.5	3.1	3.9	4.5	4.7
46.0			3.1	3.7	3.8
48.0			2.4	3.0	3.1
50.0				2.3	2.4
θ (°)	10~ 81	29~ 81	30~ 81	35~ 81	41~ 81
標準フック	80t			35t	
フック重量	1550kg			950kg	
標準巻掛本数	5		4		

カウンタウエイト 47t、アウトリガ張出幅 8.5m

PS+ブーム+12.0mフィックスジブ

単位:t

ブーム長さ(m) 作業半径(m)	40.4	45.4	50.5	55.6	60.0
9.0	47.4				
10.0	47.4				
11.0	47.4	38.4			
12.0	46.8	38.4	29.6		
14.0	42.5	38.4	27.4	23.7	20.9
16.0	38.9	38.4	25.6	22.0	20.9
18.0	32.3	32.8	24.0	20.6	19.7
20.0	26.9	27.3	22.5	19.3	18.5
22.0	22.6	23.1	21.3	18.2	17.5
24.0	19.3	19.7	20.1	17.2	16.5
26.0	16.5	16.9	17.4	16.3	15.7
28.0	14.2	14.6	15.0	15.5	15.0
30.0	12.3	12.7	13.1	13.6	13.6
32.0	10.6	11.0	11.4	12.0	11.9
34.0	9.1	9.5	10.0	10.5	10.4
36.0	7.7	8.1	8.7	9.2	9.2
38.0	6.4	6.9	7.4	8.0	7.9
40.0	5.3	5.7	6.3	6.9	6.8
42.0	4.3	4.7	5.3	5.9	5.8
44.0	3.4	3.8	4.4	5.0	4.9
46.0	2.6	3.0	3.6	4.1	4.1
48.0			2.8	3.4	3.3
50.0			2.2	2.7	2.6
54.0				1.5	
θ (°)	26~ 83	36~ 83	36~ 83	37~ 83	47~ 83
標準フック	80t			35t	
フック重量	1550kg			950kg	
標準巻掛本数	4		3		

カウンタウエイト 47t、アウトリガ張出幅 8.5m

PS+ブーム+18.0mフィックスジブ

単位:t

ブーム長さ(m) 作業半径(m)	40.4	45.4	50.5	55.6	60.0
11.0	33.3				
12.0	33.2	29.1			
14.0	31.1	29.1	22.8	18.0	
16.0	28.6	28.5	22.3	18.0	15.8
18.0	26.2	27.0	20.8	18.0	15.4
20.0	24.2	25.7	19.5	17.0	15.0
22.0	22.5	23.7	18.3	15.9	14.6
24.0	20.1	20.3	17.3	15.0	14.1
26.0	17.4	17.5	16.4	14.2	13.7
28.0	15.0	15.2	15.6	13.5	13.1
30.0	13.1	13.2	13.7	12.8	12.4
32.0	11.4	11.5	12.0	12.2	11.9
34.0	10.0	10.1	10.6	10.8	10.7
36.0	8.6	8.8	9.3	9.6	9.4
38.0	7.4	7.5	8.1	8.4	8.3
40.0	6.2	6.4	6.9	7.3	7.1
42.0	5.2	5.4	5.9	6.3	6.1
44.0	4.3	4.5	5.0	5.4	5.2
46.0	3.5	3.7	4.2	4.5	4.4
48.0	2.8	2.9	3.4	3.8	3.6
50.0		2.3	2.8	3.1	3.0
54.0			1.6	1.9	1.8
θ (°)	34~ 83	38~ 83	38~ 83	44~ 83	48~ 83
標準フック	35t				
フック重量	950kg				
標準巻掛本数	3			2	

カウンタウエイト 47t、アウトリガ張出幅 8.5m

PS+ブーム+24.0mフィックスジブ

単位:t

ブーム長さ(m) 作業半径(m)	40.4	45.4	50.5	55.6	60.0
12.0	23.7				
14.0	23.0	21.0			
16.0	21.6	21.0	16.8	13.2	
18.0	20.4	19.9	16.8	13.2	11.2
20.0	18.8	19.0	16.8	13.2	10.9
22.0	17.3	18.0	16.0	13.2	10.6
24.0	16.1	17.2	15.0	13.2	10.2
26.0	15.0	16.3	14.2	12.5	9.8
28.0	14.0	15.2	13.4	11.8	9.4
30.0	13.2	13.6	12.7	11.2	9.1
32.0	11.9	12.0	12.1	10.7	8.7
34.0	10.4	10.5	10.7	10.1	8.3
36.0	9.2	9.2	9.4	9.6	7.9
38.0	7.9	8.0	8.2	8.5	7.5
40.0	6.8	6.8	7.1	7.4	7.1
42.0	5.7	5.8	6.1	6.3	6.2
44.0	4.8	4.9	5.2	5.4	5.2
46.0	4.0	4.1	4.4	4.6	4.4
48.0	3.3	3.3	3.6	3.8	3.7
50.0	2.6	2.6	2.9	3.2	3.0
54.0			1.7	1.9	
θ (°)	39~ 83	44~ 83	44~ 83	49~ 83	56~ 83
標準フック	35t				12.2t
フック重量	950kg				440kg
標準巻掛本数	2		1		

PS+フィックスジブ

カウンタウエイト 47t、アウトリガ張出幅 8.0m

PS+ブーム+6.0mフィックスジブ

単位:t

ブーム長さ(m) 作業半径(m)	40.4	45.4	50.5	55.6	60.0
8.0	58.6				
9.0	58.6	51.2			
10.0	58.6	51.2	37.9		
11.0	58.6	51.2	36.5	30.3	
12.0	58.6	51.2	35.1	29.1	27.7
14.0	45.1	45.8	32.8	27.1	25.8
16.0	35.7	36.3	30.8	25.3	24.2
18.0	29.0	29.6	29.1	23.8	22.8
20.0	23.9	24.5	25.3	22.5	21.5
22.0	20.0	20.6	21.4	21.3	20.4
24.0	16.9	17.4	18.2	18.7	18.9
26.0	14.3	14.9	15.6	16.1	16.3
28.0	12.2	12.7	13.5	14.0	14.1
30.0	10.4	10.9	11.6	12.1	12.3
32.0	8.6	9.2	10.1	10.6	10.7
34.0	7.1	7.7	8.6	9.2	9.3
36.0	5.8	6.4	7.2	7.9	8.0
38.0	4.6	5.2	6.1	6.7	6.8
40.0	3.6	4.2	5.0	5.6	5.7
42.0	2.6	3.2	4.1	4.7	4.8
44.0		2.4	3.2	3.8	3.9
46.0			2.4	3.0	3.2
48.0				2.3	2.4
50.0				1.7	1.8
$\theta(^{\circ})$	21~ 81	29~ 81	34~ 81	35~ 81	41~ 81
標準フック	80t			35t	
フック重量	1550kg			950kg	
標準巻掛本数	5		4		

カウンタウエイト 47t、アウトリガ張出幅 8.0m

PS+ブーム+12.0mフィックスジブ

単位:t

ブーム長さ(m) 作業半径(m)	40.4	45.4	50.5	55.6	60.0
9.0	47.4				
10.0	47.4				
11.0	47.4	38.4			
12.0	46.8	38.4	29.6		
14.0	42.5	38.4	27.4	23.7	20.9
16.0	36.8	37.3	25.6	22.0	20.9
18.0	30.0	30.4	24.0	20.6	19.7
20.0	24.9	25.3	22.5	19.3	18.5
22.0	20.9	21.4	21.3	18.2	17.5
24.0	17.8	18.2	18.6	17.2	16.5
26.0	15.2	15.6	16.0	16.3	15.7
28.0	13.0	13.4	13.9	14.4	14.3
30.0	11.2	11.6	12.0	12.5	12.5
32.0	9.6	10.0	10.5	11.0	10.9
34.0	8.1	8.5	9.1	9.6	9.5
36.0	6.7	7.2	7.7	8.3	8.2
38.0	5.5	6.0	6.5	7.1	7.0
40.0	4.5	4.9	5.5	6.0	6.0
42.0	3.6	4.0	4.5	5.1	5.0
44.0	2.7	3.1	3.6	4.2	4.1
46.0			2.9	3.4	3.4
48.0				2.2	2.7
50.0				1.5	2.1
$\theta(^{\circ})$	31~ 83	40~ 83	36~ 83	43~ 83	47~ 83
標準フック	80t			35t	
フック重量	1550kg			950kg	
標準巻掛本数	4		3		2

カウンタウエイト 47t、アウトリガ張出幅 8.0m

PS+ブーム+18.0mフィックスジブ

単位:t

ブーム長さ(m) 作業半径(m)	40.4	45.4	50.5	55.6	60.0
11.0	33.3				
12.0	33.2	29.1			
14.0	31.1	29.1	22.8	18.0	
16.0	28.6	28.5	22.3	18.0	15.8
18.0	26.2	27.0	20.8	18.0	15.4
20.0	24.2	25.7	19.5	17.0	15.0
22.0	21.8	22.0	18.3	15.9	14.6
24.0	18.6	18.8	17.3	15.0	14.1
26.0	16.0	16.2	16.4	14.2	13.7
28.0	13.8	14.0	14.5	13.5	13.1
30.0	12.0	12.1	12.6	12.8	12.4
32.0	10.4	10.6	11.0	11.3	11.2
34.0	9.0	9.2	9.6	9.9	9.8
36.0	7.7	7.8	8.4	8.7	8.6
38.0	6.5	6.6	7.2	7.5	7.4
40.0	5.4	5.6	6.1	6.4	6.3
42.0	4.4	4.6	5.1	5.5	5.3
44.0	3.6	3.7	4.3	4.6	4.5
46.0	2.8	3.0	3.5	3.8	3.7
48.0		2.3	2.8	3.1	3.0
50.0		1.6	2.1	2.5	2.3
$\theta(^{\circ})$	37~ 83	38~ 83	44~ 83	48~ 83	52~ 83
標準フック	35t				
フック重量	950kg				
標準巻掛本数	3			2	

カウンタウエイト 47t、アウトリガ張出幅 8.0m

PS+ブーム+24.0mフィックスジブ

単位:t

ブーム長さ(m) 作業半径(m)	40.4	45.4	50.5	55.6	60.0
12.0	23.7				
14.0	23.0	21.0			
16.0	21.6	21.0	16.8	13.2	
18.0	20.4	19.9	16.8	13.2	11.2
20.0	18.8	19.0	16.8	13.2	10.9
22.0	17.3	18.0	16.0	13.2	10.6
24.0	16.1	17.2	15.0	13.2	10.2
26.0	15.0	16.3	14.2	12.5	9.8
28.0	14.0	14.4	13.4	11.8	9.4
30.0	12.5	12.5	12.7	11.2	9.1
32.0	10.9	11.0	11.2	10.7	8.7
34.0	9.5	9.6	9.8	10.0	8.3
36.0	8.2	8.3	8.6	8.8	7.9
38.0	7.0	7.1	7.3	7.6	7.4
40.0	5.9	6.0	6.3	6.5	6.3
42.0	5.0	5.0	5.3	5.5	5.4
44.0	4.1	4.1	4.4	4.7	4.5
46.0	3.3	3.4	3.6	3.9	3.7
48.0	2.6	2.6	2.9	3.2	3.0
50.0	1.9	2.0	2.3	2.5	
$\theta(^{\circ})$	39~ 83	44~ 83	49~ 83	53~ 83	57~ 83
標準フック	35t				12.2t
フック重量	950kg				440kg
標準巻掛本数	2				1

カウンタウエイト 47t、アウトリガ張出幅 6.8m

PS+ブーム+6.0mフィックスジブ

単位:t

ブーム長さ(m) 作業半径(m)	40.4	45.4	50.5	55.6	60.0
8.0	58.6				
9.0	58.6	51.2			
10.0	58.6	51.2	37.9		
11.0	56.0	51.2	36.5	30.3	
12.0	48.2	48.9	35.1	29.1	27.7
14.0	37.0	37.6	32.8	27.1	25.8
16.0	29.3	29.9	30.8	25.3	24.2
18.0	23.7	24.3	25.1	23.8	22.8
20.0	19.5	20.1	20.9	21.4	21.5
22.0	16.2	16.8	17.5	18.0	18.2
24.0	13.5	14.1	14.8	15.3	15.5
26.0	11.3	11.9	12.6	13.1	13.2
28.0	9.4	10.0	10.7	11.2	11.4
30.0	7.6	8.2	9.1	9.6	9.8
32.0	6.1	6.7	7.6	8.2	8.3
34.0	4.7	5.4	6.2	6.8	7.0
36.0	3.6	4.2	5.0	5.6	5.8
38.0	2.5	3.2	4.0	4.6	4.7
40.0			3.1	3.7	3.8
42.0				2.8	3.0
44.0				2.1	2.2
$\theta (^{\circ})$	33~ 81	42~ 81	44~ 81	44~ 81	49~ 81
標準フック	80t			35t	
フック重量	1550kg			950kg	
標準巻掛本数	5		4	3	

カウンタウエイト 47t、アウトリガ張出幅 6.8m

PS+ブーム+12.0mフィックスジブ

単位:t

ブーム長さ(m) 作業半径(m)	40.4	45.4	50.5	55.6	60.0
9.0	47.4				
10.0	47.4				
11.0	47.4	38.4			
12.0	46.8	38.4	29.6		
14.0	38.1	38.4	27.4	23.7	20.9
16.0	30.3	30.8	25.6	22.0	20.9
18.0	24.7	25.1	24.0	20.6	19.7
20.0	20.4	20.9	21.3	19.3	18.5
22.0	17.1	17.5	17.9	18.2	17.5
24.0	14.4	14.8	15.2	15.8	15.7
26.0	12.2	12.5	13.0	13.5	13.4
28.0	10.3	10.7	11.1	11.6	11.6
30.0	8.6	9.0	9.5	10.0	10.0
32.0	7.0	7.5	8.0	8.6	8.5
34.0	5.7	6.1	6.7	7.3	7.2
36.0	4.5	4.9	5.5	6.1	6.0
38.0	3.5	3.9	4.4	5.0	4.9
40.0	2.6	3.0	3.5	4.1	4.0
42.0			2.7	3.2	3.2
44.0			1.9	2.5	2.4
46.0				1.8	
$\theta (^{\circ})$	39~ 83	46~ 83	45~ 83	48~ 83	54~ 83
標準フック	80t			35t	
フック重量	1550kg			950kg	
標準巻掛本数	4		3	2	

カウンタウエイト 47t、アウトリガ張出幅 6.8m

PS+ブーム+18.0mフィックスジブ

単位:t

ブーム長さ(m) 作業半径(m)	40.4	45.4	50.5	55.6	60.0
11.0	33.3				
12.0	33.2	29.1			
14.0	31.1	29.1	22.8	18.0	
16.0	28.6	28.5	22.3	18.0	15.8
18.0	25.6	25.8	20.8	18.0	15.4
20.0	21.3	21.5	19.5	17.0	15.0
22.0	17.9	18.1	18.3	15.9	14.6
24.0	15.2	15.3	15.8	15.0	14.1
26.0	13.0	13.1	13.6	13.9	13.7
28.0	11.1	11.2	11.7	12.0	11.9
30.0	9.5	9.6	10.1	10.4	10.2
32.0	8.0	8.1	8.7	9.0	8.9
34.0	6.6	6.8	7.3	7.7	7.5
36.0	5.4	5.6	6.1	6.5	6.3
38.0	4.4	4.5	5.1	5.4	5.3
40.0	3.4	3.6	4.1	4.5	4.3
42.0	2.6	2.8	3.3	3.6	3.5
44.0		2.0	2.5	2.8	2.7
46.0			1.8	2.2	
$\theta (^{\circ})$	44~ 83	47~ 83	49~ 83	52~ 83	57~ 83
標準フック	35t				12.2t
フック重量	950kg				440kg
標準巻掛本数	3			2	

カウンタウエイト 47t、アウトリガ張出幅 6.8m

PS+ブーム+24.0mフィックスジブ

単位:t

ブーム長さ(m) 作業半径(m)	40.4	45.4	50.5	55.6	60.0
12.0	23.7				
14.0	23.0	21.0			
16.0	21.6	21.0	16.8	13.2	
18.0	20.4	19.9	16.8	13.2	11.2
20.0	18.8	19.0	16.8	13.2	10.9
22.0	17.3	18.0	16.0	13.2	10.6
24.0	15.7	15.8	15.0	13.2	10.2
26.0	13.5	13.5	13.7	12.5	9.8
28.0	11.6	11.6	11.9	11.8	9.4
30.0	10.0	10.0	10.2	10.4	9.1
32.0	8.5	8.6	8.8	9.0	8.7
34.0	7.2	7.2	7.5	7.7	7.5
36.0	6.0	6.0	6.3	6.5	6.3
38.0	4.9	4.9	5.2	5.5	5.3
40.0	3.9	4.0	4.3	4.5	4.3
42.0	3.1	3.1	3.4	3.7	3.5
44.0	2.3	2.4	2.7	2.9	
46.0	1.6				
$\theta (^{\circ})$	44~ 83	51~ 83	55~ 83	58~ 83	62~ 83
標準フック	35t				12.2t
フック重量	950kg				440kg
標準巻掛本数	2				1

PS+フィックスジブ

カウンタウエイト 25t、アウトリガ張出幅 8.5m

PS+ブーム+6.0mフィックスジブ

単位:t

ブーム長さ(m) 作業半径(m)	40.4	45.4	50.5	55.6	60.0
8.0	58.6				
9.0	58.6	51.2			
10.0	58.6	51.2	37.9		
11.0	53.7	51.2	36.5	30.3	
12.0	45.6	46.4	35.1	29.1	27.7
14.0	33.9	34.6	32.8	27.1	25.8
16.0	26.2	26.9	27.8	25.3	24.2
18.0	20.8	21.4	22.2	22.8	22.8
20.0	16.7	17.3	18.1	18.7	18.8
22.0	13.5	14.1	14.9	15.5	15.6
24.0	11.0	11.6	12.4	12.9	13.0
26.0	8.9	9.5	10.3	10.8	10.9
28.0	7.0	7.6	8.5	9.1	9.2
30.0	5.3	6.0	6.9	7.5	7.6
32.0	3.9	4.5	5.4	6.1	6.2
34.0	2.7	3.3	4.2	4.8	5.0
36.0			3.1	3.7	3.9
38.0				2.8	2.9
θ(°)	42~ 81	48~ 81	50~ 81	52~ 81	56~ 81
標準フック	80t			35t	
フック重量	1550kg			950kg	
標準巻掛本数	5		4		

カウンタウエイト 25t、アウトリガ張出幅 8.5m

PS+ブーム+12.0mフィックスジブ

単位:t

ブーム長さ(m) 作業半径(m)	40.4	45.4	50.5	55.6	60.0
9.0	47.4				
10.0	47.4				
11.0	47.4	38.4			
12.0	46.8	38.4	29.6		
14.0	35.2	35.7	27.4	23.7	20.9
16.0	27.4	27.9	25.6	22.0	20.9
18.0	21.8	22.3	22.8	20.6	19.7
20.0	17.7	18.1	18.6	19.2	18.5
22.0	14.5	14.9	15.4	16.0	15.9
24.0	12.0	12.4	12.8	13.4	13.3
26.0	9.9	10.3	10.7	11.3	11.2
28.0	8.0	8.5	9.0	9.5	9.4
30.0	6.4	6.8	7.4	8.0	7.9
32.0	4.9	5.4	5.9	6.6	6.5
34.0	3.7	4.1	4.7	5.3	5.2
36.0	2.6	3.0	3.6	4.2	4.1
38.0			2.6	3.2	3.2
θ(°)	46~ 83	51~ 83	53~ 83	57~ 83	59~ 83
標準フック	80t			35t	
フック重量	1550kg			950kg	
標準巻掛本数	4		3		2

カウンタウエイト 25t、アウトリガ張出幅 8.5m

PS+ブーム+18.0mフィックスジブ

単位:t

ブーム長さ(m) 作業半径(m)	40.4	45.4	50.5	55.6	60.0
11.0	33.3				
12.0	33.2	29.1			
14.0	31.1	29.1	22.8	18.0	
16.0	28.5	28.5	22.3	18.0	15.8
18.0	22.8	23.0	20.8	18.0	15.4
20.0	18.7	18.8	19.4	17.0	15.0
22.0	15.4	15.6	16.1	15.9	14.6
24.0	12.8	13.0	13.5	13.8	13.6
26.0	10.7	10.9	11.4	11.6	11.5
28.0	9.0	9.1	9.6	9.9	9.7
30.0	7.3	7.5	8.1	8.4	8.3
32.0	5.9	6.1	6.6	7.0	6.8
34.0	4.7	4.8	5.4	5.7	5.6
36.0	3.6	3.7	4.3	4.6	4.5
38.0		2.8	3.3	3.7	
θ(°)	52~ 83	54~ 83	57~ 83	60~ 83	64~ 83
標準フック	35t				
フック重量	950kg				
標準巻掛本数	3			2	

カウンタウエイト 25t、アウトリガ張出幅 8.5m

PS+ブーム+24.0mフィックスジブ

単位:t

ブーム長さ(m) 作業半径(m)	40.4	45.4	50.5	55.6	60.0
12.0	23.7				
14.0	23.0	21.0			
16.0	21.6	21.0	16.8	13.2	
18.0	20.4	19.9	16.8	13.2	11.2
20.0	18.8	19.0	16.8	13.2	10.9
22.0	16.0	16.1	16.0	13.2	10.6
24.0	13.4	13.4	13.7	13.2	10.2
26.0	11.3	11.3	11.6	11.8	9.8
28.0	9.5	9.5	9.8	10.0	9.4
30.0	7.9	8.0	8.3	8.5	8.3
32.0	6.5	6.5	6.8	7.1	6.9
34.0	5.2	5.3	5.6	5.8	5.6
36.0	4.1	4.2	4.5	4.7	4.5
38.0	3.1	3.2	3.5	3.7	
θ(°)	54~ 83	58~ 83	61~ 83	63~ 83	67~ 83
標準フック	35t				12.2t
フック重量	950kg				440kg
標準巻掛本数	2				1

カウンタウエイト 25t、アウトリガ張出幅 8.0m

PS+ブーム+6.0mフィックスジブ

単位:t

ブーム長さ(m) 作業半径(m)	40.4	45.4	50.5	55.6	60.0
8.0	58.6				
9.0	58.6	51.2			
10.0	58.6	51.2	37.9		
11.0	49.2	50.0	36.5	30.3	
12.0	41.7	42.4	35.1	29.1	27.7
14.0	31.1	31.7	32.7	27.1	25.8
16.0	24.0	24.6	25.5	25.3	24.2
18.0	18.9	19.6	20.4	21.0	21.1
20.0	15.2	15.8	16.6	17.1	17.3
22.0	12.2	12.8	13.6	14.1	14.3
24.0	9.9	10.4	11.2	11.7	11.9
26.0	7.7	8.4	9.2	9.8	9.9
28.0	5.9	6.6	7.5	8.1	8.2
30.0	4.3	5.0	5.9	6.5	6.7
32.0	3.0	3.7	4.6	5.2	5.3
34.0			3.4	4.0	4.2
36.0				3.0	3.1
$\theta (^{\circ})$	45~ 81	51~ 81	53~ 81	54~ 81	58~ 81
標準フック	80t			35t	
フック重量	1550kg			950kg	
標準巻掛本数	5		4		3

カウンタウエイト 25t、アウトリガ張出幅 8.0m

PS+ブーム+12.0mフィックスジブ

単位:t

ブーム長さ(m) 作業半径(m)	40.4	45.4	50.5	55.6	60.0
9.0	47.4				
10.0	47.4				
11.0	47.4	38.4			
12.0	43.0	38.4	29.6		
14.0	32.3	32.8	27.4	23.7	20.9
16.0	25.1	25.6	25.6	22.0	20.9
18.0	20.0	20.4	20.9	20.6	19.7
20.0	16.2	16.6	17.1	17.6	17.6
22.0	13.2	13.6	14.0	14.6	14.5
24.0	10.8	11.2	11.6	12.2	12.1
26.0	8.8	9.2	9.7	10.2	10.1
28.0	7.0	7.4	8.0	8.6	8.5
30.0	5.4	5.8	6.4	7.0	6.9
32.0	4.0	4.5	5.0	5.7	5.6
34.0	2.9	3.3	3.9	4.5	4.4
36.0			2.8	3.4	
$\theta (^{\circ})$	49~ 83	54~ 83	55~ 83	59~ 83	63~ 83
標準フック	80t			35t	
フック重量	1550kg			950kg	
標準巻掛本数	4		3		2

カウンタウエイト 25t、アウトリガ張出幅 8.0m

PS+ブーム+18.0mフィックスジブ

単位:t

ブーム長さ(m) 作業半径(m)	40.4	45.4	50.5	55.6	60.0
11.0	33.3				
12.0	33.2	29.1			
14.0	31.1	29.1	22.8	18.0	
16.0	26.2	26.3	22.3	18.0	15.8
18.0	21.0	21.1	20.8	18.0	15.4
20.0	17.1	17.2	17.8	17.0	15.0
22.0	14.1	14.2	14.7	15.0	14.6
24.0	11.6	11.8	12.3	12.6	12.4
26.0	9.7	9.8	10.3	10.6	10.5
28.0	7.9	8.1	8.6	8.9	8.8
30.0	6.4	6.5	7.1	7.4	7.3
32.0	5.0	5.2	5.7	6.1	5.9
34.0	3.8	4.0	4.5	4.9	4.7
36.0		3.0	3.5	3.8	
$\theta (^{\circ})$	55~ 83	56~ 83	59~ 83	62~ 83	66~ 83
標準フック	35t				
フック重量	950kg				
標準巻掛本数	3			2	

カウンタウエイト 25t、アウトリガ張出幅 8.0m

PS+ブーム+24.0mフィックスジブ

単位:t

ブーム長さ(m) 作業半径(m)	40.4	45.4	50.5	55.6	60.0
12.0	23.7				
14.0	23.0	21.0			
16.0	21.6	21.0	16.8	13.2	
18.0	20.4	19.9	16.8	13.2	11.2
20.0	17.7	17.8	16.8	13.2	10.9
22.0	14.6	14.7	14.9	13.2	10.6
24.0	12.2	12.2	12.5	12.7	10.2
26.0	10.2	10.2	10.5	10.7	9.8
28.0	8.5	8.6	8.8	9.0	8.8
30.0	6.9	7.0	7.3	7.5	7.3
32.0	5.6	5.6	5.9	6.1	5.9
34.0	4.4	4.4	4.7	5.0	4.8
36.0	3.3	3.4	3.7		
$\theta (^{\circ})$	56~ 83	60~ 83	62~ 83	66~ 83	68~ 83
標準フック	35t				12.2t
フック重量	950kg				440kg
標準巻掛本数	2				1

PS+フィックスジブ

カウンタウエイト 25t、アウトリガ張出幅 6.8m

PS+ブーム+6.0mフィックスジブ

単位:t

ブーム長さ(m) 作業半径(m)	40.4	45.4	50.5	55.6	60.0
8.0	58.6				
9.0	56.9	51.2			
10.0	46.5	47.3	37.9		
11.0	38.9	39.6	36.5	30.3	
12.0	33.1	33.8	34.7	29.1	27.7
14.0	24.7	25.3	26.2	26.8	25.8
16.0	19.0	19.6	20.4	21.0	21.2
18.0	14.8	15.4	16.2	16.8	16.9
20.0	11.7	12.2	13.0	13.5	13.7
22.0	9.2	9.8	10.5	11.0	11.2
24.0	6.9	7.6	8.5	9.0	9.1
26.0	5.0	5.7	6.6	7.2	7.4
28.0	3.5	4.1	5.0	5.6	5.8
30.0				4.3	4.4
$\theta (^{\circ})$	52~ 81	57~ 81	60~ 81	61~ 81	64~ 81
標準フック	80t		35t		
フック重量	1550kg		950kg		
標準巻掛本数	5	4	3		

カウンタウエイト 25t、アウトリガ張出幅 6.8m

PS+ブーム+12.0mフィックスジブ

単位:t

ブーム長さ(m) 作業半径(m)	40.4	45.4	50.5	55.6	60.0
9.0	47.4				
10.0	47.4				
11.0	40.2	38.4			
12.0	34.3	34.8	29.6		
14.0	25.8	26.3	26.8	23.7	20.9
16.0	20.0	20.5	20.9	21.6	20.9
18.0	15.8	16.2	16.7	17.3	17.2
20.0	12.6	13.0	13.5	14.0	14.0
22.0	10.1	10.5	10.9	11.5	11.4
24.0	7.9	8.4	8.9	9.4	9.4
26.0	6.1	6.5	7.1	7.7	7.6
28.0	4.5	4.9	5.5	6.1	6.0
30.0			4.1	4.7	4.6
$\theta (^{\circ})$	58~ 83	61~ 83	62~ 83	65~ 83	67~ 83
標準フック	80t		35t		
フック重量	1550kg		950kg		
標準巻掛本数	4	3	2		

油圧チルトジブ

■ 油圧チルトジブ(HLJ)の構成

記号	名称	長さ
③	ミドルBジブ	12.0 m
④	レデューサジブ	3.0 m
⑥	ミドルCジブ	6.0 m
⑦	ミドルDジブ	12.0 m
⑧	トップジブ	6.0 m
⑨	HLJベースジブ	2.5 m
⑩	ヘビートップジブ	1.0 m

2.0m+3.5mジブ

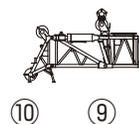

2.0m+11.5mジブ

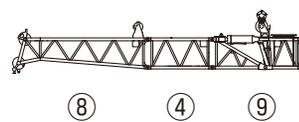

2.0m+17.5mジブ

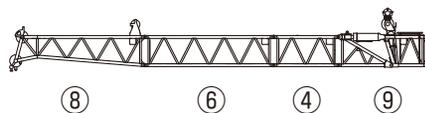

2.0m+23.5mジブ

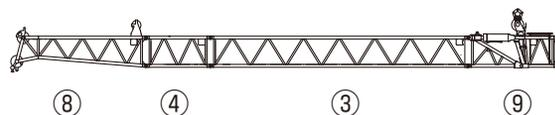

2.0m+29.5mジブ

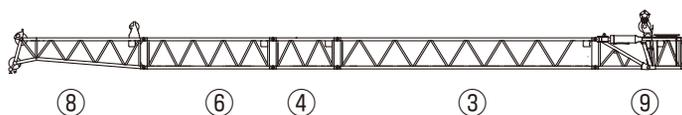

2.0m+35.5mジブ

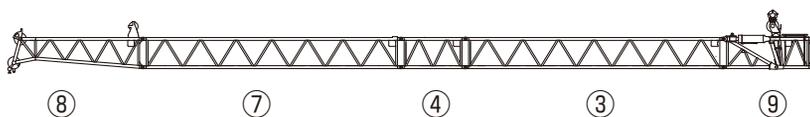

2.0m+41.5mジブ

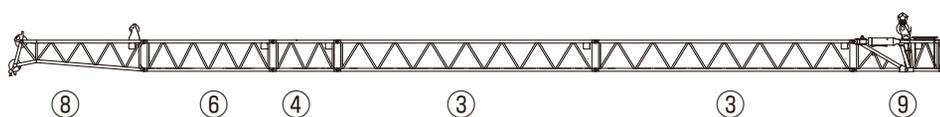

2.0m+47.5mジブ

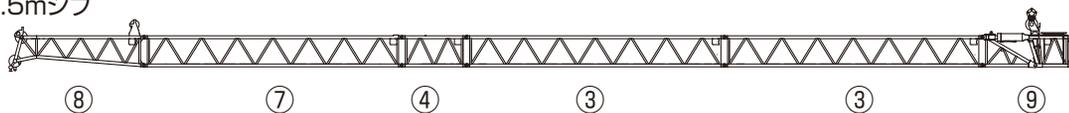

ブーム+油圧チルトジブ(HLJ)作業半径-揚程図

ブーム+油圧チルトジブ

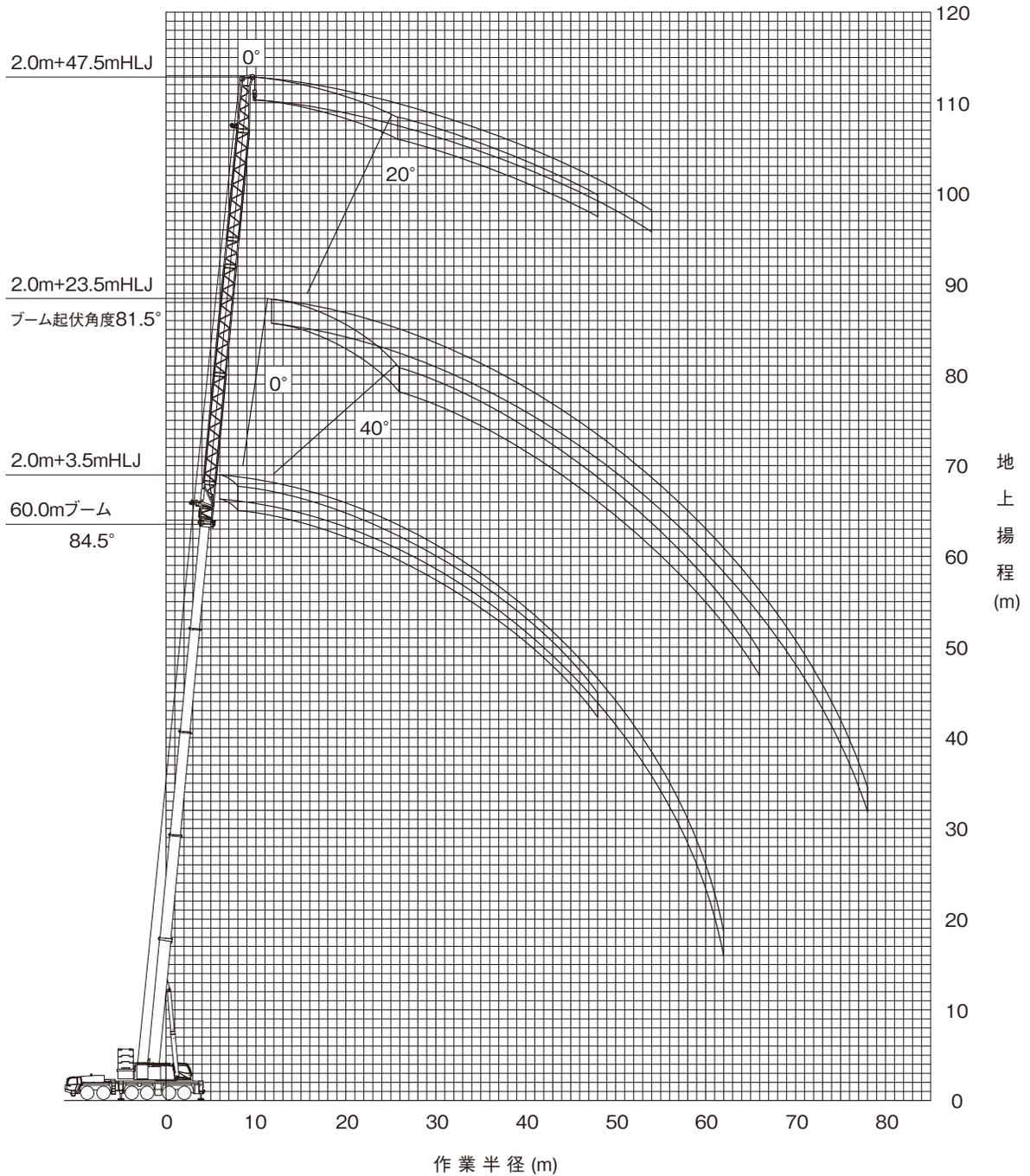

(注意)

- ◆ 上図はブームおよびジブのたわみを含んでいません。
- ◆ カウンタウエイト118t、アウトリガ張出幅8.5m または8.0mの性能を図示しています。

HLJ

油圧チルトジブ

ブーム+油圧チルトジブ(HLJ) 定格総荷重表

■ 定格総荷重表注意事項

◆性能設定のあるカウンタウエイトとアウトリガ張出幅の組合せを、下表に○印で示します。

アウトリガ張出幅 \ カウンタウエイト	118 t	98 t	78 t	58 t	47 t	25 t
8.5 m	○	○	○	○	○	○
8.0 m	○	○	○	○	○	○
6.8 m			○	○	○	○

◆定格総荷重は、つり具質量とフック質量(80トンフック: 1,550kg、35トンフック:950kg、12.2トンフック:440kg)を含んだ値を示します。

◆定格総荷重は、ブームとジブのたわみを含んだ実際の作業半径に基づいています。

◆各ブーム長さにおける各伸縮ブームの伸長状態(伸長割合%)は、下表のとおりです。

ブーム長さ	40.4 m	45.4 m	50.5 m	55.6 m	60.0 m
伸縮ブーム1	90	90	90	90	100
伸縮ブーム2	90	90	90	90	100
伸縮ブーム3	45	90	90	90	100
伸縮ブーム4	0	0	45	90	100

◆Bピン(ブーム固定ピン)を挿入していないときの定格総荷重は、26.6t以下になります。

◆定格総荷重表中の標準巻掛本数よりも少ない本数で使用する場合、最大荷重の上限は下表のとおりです。

巻掛本数	4本	3本	2本	1本
最大荷重	47.4t	35.9t	24.1t	12.2t

◆定格総荷重は、アウトリガを水平堅土上に設置したときの値です。

◆定格総荷重表は、風による影響を含んでいません。瞬間最大風速が10m/s以上の風速では、クレーン作業を中止してください。

定格総荷重表中の線、および用語説明

◆太線より上側はクレーンの強度に、下側はクレーンの安定に基づいています。

◆「オフセット」はブームの中心線とジブの中心線とのなす角度を示します。

◆「 θ (°)」は、無負荷状態で作動可能なブーム起伏角度範囲を示します。

カウンタウエイト 118t、アウトリガ張出幅 8.5m、または 8.0m

ブーム+2.0m+3.5m油圧チルトジブ

単位:t

ブーム長さ(m) 作業半径 (m)	40.4			45.4			50.5			55.6			60.0		
	オフセット			オフセット			オフセット			オフセット			オフセット		
	0°	20°	40°	0°	20°	40°	0°	20°	40°	0°	20°	40°	0°	20°	40°
8.0	47.7			38.0											
9.0	44.9	42.5													
10.0	42.5	40.3	38.9	36.1	33.9			28.4							
11.0	40.3	38.4	37.1	34.4	32.4	31.1	27.0	25.5		23.9					
12.0	38.3	36.6	35.5	32.9	31.1	29.9	25.7	24.4	23.5	22.8	21.5				
14.0	35.0	33.6	32.7	30.3	28.8	27.8	23.6	22.5	21.7	20.8	19.9	19.2	19.7		
16.0	32.2	31.0	30.3	28.1	26.8	26.0	21.8	20.9	20.3	19.2	18.5	18.0	18.2	17.5	17.1
18.0	29.9	28.9	28.3	26.0	25.1	24.4	20.3	19.5	19.0	17.8	17.2	16.8	16.9	16.3	15.9
20.0	27.9	27.0	26.5	24.2	23.6	23.1	19.0	18.3	17.9	16.6	16.1	15.8	15.7	15.2	14.9
22.0	26.1	25.4	25.0	22.6	22.1	21.8	17.9	17.3	16.9	15.6	15.1	14.8	14.7	14.3	14.1
24.0	24.6	24.0	23.7	21.3	20.8	20.6	16.9	16.3	16.0	14.7	14.3	14.0	13.9	13.5	13.3
26.0	23.3	22.8	22.5	20.0	19.7	19.5	16.0	15.5	15.2	13.9	13.5	13.3	13.1	12.8	12.6
28.0	21.9	21.7	21.5	19.0	18.6	18.5	15.2	14.8	14.6	13.1	12.8	12.6	12.4	12.1	12.0
30.0	20.0	20.1	20.2	18.0	17.7	17.6	14.5	14.1	13.9	12.5	12.2	12.1	11.8	11.5	11.4
32.0	18.3	18.4	18.4	17.2	16.9	16.8	13.9	13.6	13.4	11.9	11.7	11.5	11.2	11.0	10.9
34.0	16.8	16.9	16.9	16.3	16.2	16.1	13.3	13.0	12.9	11.4	11.2	11.0	10.7	10.5	10.4
36.0	15.4	15.5		14.9	15.0	15.0	12.8	12.6	12.4	10.9	10.7	10.6	10.3	10.1	10.0
38.0	14.2	14.3		13.7	13.8	13.8	12.4	12.1	12.0	10.5	10.3	10.2	9.8	9.7	9.6
40.0	13.1	13.1		12.6	12.7		12.0	11.7	11.7	10.1	9.9	9.9	9.5	9.3	9.2
42.0	12.1			11.7	11.7		11.6	11.4	11.4	9.7	9.6	9.5	9.1	9.0	8.9
44.0	5.6			10.8	10.8		10.8	10.8		9.4	9.3	9.2	8.8	8.7	8.6
46.0				10.0	10.0		10.0	10.0		9.1	9.0	9.0	8.5	8.4	8.3
48.0				9.0			9.3	9.3		8.8	8.7		8.2	8.1	8.1
50.0							8.6	8.6		8.6	8.5		8.0	7.9	
54.0							4.1			7.4	7.5		7.1	7.2	
58.0										6.4			6.1	6.1	
62.0													5.2		
θ(°)	0~ 84.5	27~ 84.5	43~ 84.5	13~ 84.5	23~ 84.5	42~ 84.5	0~ 84.5	25~ 84.5	42~ 84.5	13~ 84.5	27~ 84.5	42~ 84.5	15~ 84.5	27~ 84.5	45~ 84.5
標準フック	80t						35t								
フック重量	1550kg						950kg								
標準巻掛本数	5						3								

カウンタウエイト 118t、アウトリガ張出幅 8.5m、または 8.0m

ブーム+2.0m+11.5m油圧チルトジブ

単位:t

ブーム長さ(m) 作業半径 (m)	40.4			45.4			50.5			55.6			60.0		
	オフセット			オフセット			オフセット			オフセット			オフセット		
	0°	20°	40°	0°	20°	40°	0°	20°	40°	0°	20°	40°	0°	20°	40°
10.0	38.8														
11.0	36.7			31.1											
12.0	34.8			29.6			23.3								
14.0	31.5	27.6		27.0	23.4		21.2			18.8					
16.0	28.9	26.1	22.7	24.8	21.8		19.4	16.7		17.4	14.9		15.6		
18.0	26.6	24.2	21.8	23.0	20.4	18.8	18.0	15.8	14.0	16.0	14.0		15.1		
20.0	24.7	22.6	21.0	21.5	19.2	17.8	16.7	15.0	13.4	14.9	13.2	12.0	14.0	12.5	
22.0	23.0	21.3	20.1	20.1	18.1	16.9	15.6	14.1	12.8	13.9	12.5	11.4	13.1	11.9	
24.0	21.6	20.0	19.0	18.9	17.2	16.1	14.7	13.3	12.3	13.0	11.9	10.9	12.3	11.3	10.4
26.0	20.3	18.9	18.1	17.9	16.3	15.3	13.8	12.6	11.9	12.2	11.3	10.5	11.5	10.7	9.9
28.0	19.2	18.0	17.2	17.0	15.5	14.7	13.1	12.0	11.4	11.5	10.8	10.0	10.9	10.2	9.5
30.0	18.2	17.1	16.4	16.1	14.9	14.1	12.4	11.4	10.9	10.9	10.2	9.7	10.3	9.7	9.2
32.0	17.3	16.3	15.7	15.2	14.2	13.5	11.8	10.9	10.4	10.3	9.7	9.3	9.7	9.2	8.8
34.0	16.4	15.6	15.1	14.5	13.7	13.1	11.2	10.4	10.0	9.8	9.3	8.9	9.3	8.7	8.4
36.0	15.1	15.0	14.5	13.8	13.2	12.6	10.7	10.0	9.6	9.4	8.9	8.5	8.8	8.4	8.1
38.0	13.9	14.2	14.0	13.2	12.7	12.2	10.3	9.6	9.3	9.0	8.5	8.2	8.4	8.0	7.7
40.0	12.8	13.1	13.3	12.5	12.1	11.8	9.9	9.3	8.9	8.6	8.1	7.9	8.0	7.7	7.4
42.0	11.9	12.1	12.2	11.5	11.7	11.5	9.5	8.9	8.6	8.2	7.8	7.6	7.7	7.3	7.1
44.0	11.0	11.2		10.6	10.9	11.1	9.1	8.6	8.4	7.9	7.5	7.3	7.4	7.1	6.9
46.0	10.2	10.4		9.8	10.1	10.2	8.8	8.4	8.1	7.6	7.3	7.1	7.1	6.8	6.6
48.0	9.5	9.6		9.1	9.3		8.5	8.1	7.9	7.3	7.0	6.8	6.8	6.6	6.4
50.0	8.8			8.4	8.6		8.3	7.9	7.7	7.1	6.8	6.6	6.5	6.3	6.2
54.0				7.3	7.4		7.1	7.3		6.6	6.4	6.3	5.7	5.6	5.6
58.0							6.1	6.3		6.1	6.0		5.1	5.0	
62.0							2.0			5.3	5.4		4.5	4.5	
66.0										4.0			4.0	4.0	
70.0													3.5		
θ(°)	17~ 83	28~ 84.5	44~ 84.5	20~ 83	24~ 84.5	44~ 84.5	0~ 83	26~ 84.5	43~ 84.5	12~ 83	28~ 84.5	43~ 84.5	14~ 83	28~ 84.5	48~ 84.5
標準フック	80t						35t								
フック重量	1550kg						950kg								
標準巻掛本数	4						3								

油圧チルトジブ

カウンタウエイト 118t、アウトリガ張出幅 8.5m、または 8.0m
ブーム+2.0m+17.5m油圧チルトジブ

単位:t

ブーム長さ(m) 作業半径 (m)	40.4			45.4			50.5			55.6			60.0		
	オフセット			オフセット			オフセット			オフセット			オフセット		
	0°	20°	40°	0°	20°	40°	0°	20°	40°	0°	20°	40°	0°	20°	40°
11.0	31.5														
12.0	30.3			27.0											
14.0	28.1			24.6			19.5								
16.0	26.3	20.6		22.6			17.9			15.6			14.8		
18.0	24.6	19.5		20.8	17.9		16.5	13.4		14.5			13.7		
20.0	22.8	18.6		19.4	16.8		15.3	12.7		13.5	11.3		12.8		
22.0	21.2	17.8	14.0	18.1	15.8		14.3	12.0		12.6	10.7		12.0	10.2	
24.0	19.9	17.1	13.6	17.0	15.0	13.7	13.4	11.5	10.1	11.9	10.1		11.2	9.6	
26.0	18.6	16.4	13.3	16.0	14.2	13.1	12.5	11.0	9.7	11.1	9.6	8.7	10.5	9.2	8.3
28.0	17.6	15.8	12.9	15.1	13.5	12.5	11.8	10.5	9.3	10.5	9.2	8.3	9.9	8.7	7.9
30.0	16.6	15.3	12.7	14.4	12.9	12.0	11.2	10.1	9.0	9.9	8.8	8.0	9.3	8.4	7.6
32.0	15.7	14.6	12.4	13.6	12.3	11.5	10.6	9.6	8.7	9.3	8.4	7.7	8.8	8.0	7.3
34.0	15.0	13.9	12.2	13.0	11.8	11.1	10.1	9.2	8.5	8.8	8.1	7.4	8.3	7.7	7.1
36.0	14.3	13.3	12.0	12.4	11.3	10.6	9.6	8.8	8.2	8.4	7.7	7.1	7.9	7.4	6.8
38.0	13.6	12.8	11.8	11.9	10.9	10.3	9.2	8.4	8.0	8.0	7.4	6.9	7.5	7.0	6.6
40.0	12.7	12.3	11.7	11.4	10.5	9.9	8.8	8.1	7.7	7.6	7.1	6.7	7.2	6.7	6.4
42.0	11.7	11.8	11.4	11.0	10.1	9.6	8.4	7.8	7.4	7.3	6.8	6.5	6.9	6.4	6.2
44.0	10.9	11.2	11.1	10.4	9.8	9.3	8.0	7.5	7.1	7.0	6.5	6.3	6.5	6.2	6.0
46.0	10.1	10.4	10.6	9.6	9.5	9.1	7.7	7.2	6.9	6.7	6.3	6.1	6.3	5.9	5.7
48.0	9.3	9.6	9.8	8.9	9.2	8.8	7.5	7.0	6.7	6.4	6.0	5.9	5.9	5.6	5.5
50.0	8.7	8.9		8.2	8.6	8.6	7.2	6.7	6.5	6.2	5.8	5.6	5.5	5.3	5.3
54.0	7.5	7.7		7.1	7.3		6.7	6.3	6.1	5.7	5.4	5.3	4.8	4.7	4.7
58.0				6.1	6.2		6.0	6.0		5.3	5.1	5.0	4.2	4.1	4.2
62.0				4.5			5.1	5.3		4.8	4.7		3.6	3.6	3.7
66.0							4.4			4.3	4.3		3.2	3.2	
70.0										3.6	3.7		2.8	2.8	
74.0													2.5	2.5	
θ(°)	23~ 83	28~ 84.5	44~ 84.5	11~ 83	30~ 84.5	48~ 84.5	16~ 83	31~ 84.5	47~ 84.5	19~ 83	23~ 84.5	47~ 84.5	20~ 83	24~ 84.5	46~ 84.5
標準フック	35t						35t								
フック重量	950kg						950kg								
標準巻掛本数	3						2								

カウンタウエイト 118t、アウトリガ張出幅 8.5m、または 8.0m
ブーム+2.0m+23.5m油圧チルトジブ

単位:t

ブーム長さ(m) 作業半径 (m)	40.4			45.4			50.5			55.6			60.0		
	オフセット			オフセット			オフセット			オフセット			オフセット		
	0°	20°	40°	0°	20°	40°	0°	20°	40°	0°	20°	40°	0°	20°	40°
12.0	25.7														
14.0	23.9			22.1			17.6								
16.0	22.2			20.7			16.2			14.2					
18.0	20.8			19.3			15.0			13.1			12.4		
20.0	19.6	14.4		17.9			14.0			12.2			11.6		
22.0	18.5	13.6		16.7	13.8		13.1	10.3		11.4			10.8		
24.0	17.5	12.9		15.6	13.2		12.2	9.8		10.6	8.8		10.1		
26.0	16.6	12.3	9.3	14.7	12.6		11.4	9.4		10.0	8.3		9.5	8.0	
28.0	15.8	11.7	9.0	13.8	12.1	9.1	10.7	9.0		9.4	7.9		9.0	7.6	
30.0	15.1	11.2	8.7	13.1	11.5	8.9	10.1	8.6	7.5	8.9	7.6	6.7	8.5	7.2	
32.0	14.5	10.7	8.5	12.4	11.0	8.6	9.6	8.2	7.2	8.5	7.2	6.5	8.0	6.9	6.2
34.0	13.9	10.3	8.3	11.8	10.5	8.4	9.1	7.9	7.0	8.0	6.9	6.2	7.6	6.6	6.0
36.0	13.2	9.9	8.1	11.2	10.0	8.2	8.6	7.6	6.8	7.6	6.6	6.0	7.2	6.3	5.7
38.0	12.6	9.6	7.9	10.7	9.6	8.1	8.2	7.3	6.5	7.2	6.4	5.8	6.8	6.1	5.5
40.0	12.0	9.2	7.7	10.2	9.2	7.9	7.8	7.1	6.3	6.9	6.1	5.6	6.5	5.8	5.3
42.0	11.4	8.9	7.6	9.8	8.9	7.7	7.5	6.8	6.2	6.5	5.9	5.4	6.1	5.6	5.1
44.0	10.7	8.6	7.5	9.4	8.6	7.6	7.1	6.5	6.0	6.2	5.7	5.2	5.8	5.4	4.9
46.0	9.9	8.4	7.4	9.1	8.3	7.5	6.8	6.3	5.8	5.9	5.5	5.0	5.4	5.1	4.7
48.0	9.2	8.1	7.3	8.7	8.0	7.4	6.6	6.0	5.7	5.7	5.3	4.9	5.0	4.8	4.5
50.0	8.5	7.9	7.2	8.1	7.7	7.3	6.3	5.8	5.5	5.4	5.1	4.7	4.6	4.4	4.3
54.0	7.4	7.6	7.2	6.9	7.3	6.9	5.8	5.4	5.2	4.8	4.6	4.4	4.0	3.9	3.9
58.0	6.3	6.6		5.9	6.3	6.5	5.4	5.1	4.9	4.3	4.1	4.0	3.4	3.4	3.4
62.0	5.5			5.1	5.3		4.9	4.7	4.5	3.8	3.7	3.6	2.9	2.9	3.0
66.0				4.3	4.5		4.1	4.3		3.5	3.3	3.3	2.5	2.5	2.6
70.0							3.5	3.7		3.1	3.0		2.1	2.1	
74.0										2.8	2.8		1.8	1.8	
78.0										1.8			1.5	1.6	
θ(°)	16~ 83	33~ 84.5	45~ 84.5	19~ 83	25~ 84.5	45~ 84.5	21~ 83	27~ 84.5	45~ 84.5	12~ 83	29~ 84.5	45~ 84.5	24~ 83	30~ 84.5	50~ 84.5
標準フック	35t						35t								
フック重量	950kg						950kg								
標準巻掛本数	3						2								

カウンタウエイト 118t、アウトリガ張出幅 8.5m、または 8.0m
 ブーム+2.0m+29.5m油圧チルトジブ

単位:t

ブーム長さ(m) 作業半径 (m)	40.4			45.4			50.5			55.6			60.0		
	オフセット			オフセット			オフセット			オフセット			オフセット		
	0°	20°	40°	0°	20°	40°	0°	20°	40°	0°	20°	40°	0°	20°	40°
14.0	20.4			18.9											
16.0	19.0			17.7			14.7								
18.0	17.8			16.7			13.6			12.4					
20.0	16.7			15.7			12.6			11.4			10.9		
22.0	15.8			14.9			11.7			10.6			10.1		
24.0	14.9	10.2		14.1	10.5		11.0			9.9			9.5		
26.0	14.1	9.6		13.4	9.9		10.3	8.2		9.3			8.9		
28.0	13.4	9.1		12.7	9.4		9.8	7.8		8.7	7.2		8.3		
30.0	12.8	8.7		11.9	9.0		9.2	7.4		8.2	6.8		7.9	6.5	
32.0	12.2	8.3	6.2	11.3	8.6	6.3	8.7	7.1		7.8	6.5		7.4	6.2	
34.0	11.4	7.9	6.0	10.7	8.2	6.1	8.2	6.8	5.9	7.4	6.2		7.0	5.9	
36.0	10.7	7.6	5.9	10.2	7.9	6.0	7.8	6.5	5.7	7.0	5.9	5.3	6.7	5.5	
38.0	10.0	7.2	5.7	9.7	7.5	5.8	7.4	6.3	5.5	6.7	5.7	5.1	6.3	5.2	4.4
40.0	9.5	6.9	5.5	9.2	7.2	5.6	7.0	6.0	5.3	6.4	5.4	4.9	5.9	4.9	4.2
42.0	8.9	6.7	5.4	8.8	7.0	5.5	6.7	5.8	5.1	6.0	5.2	4.7	5.4	4.6	4.0
44.0	8.5	6.4	5.3	8.4	6.7	5.4	6.4	5.6	5.0	5.7	5.0	4.5	5.0	4.3	3.8
46.0	8.0	6.2	5.1	8.1	6.5	5.2	6.1	5.4	4.8	5.4	4.8	4.3	4.6	4.1	3.6
48.0	7.6	6.0	5.0	7.7	6.3	5.1	5.8	5.2	4.7	5.1	4.6	4.2	4.2	3.9	3.4
50.0	7.2	5.8	5.0	7.4	6.1	5.0	5.5	5.1	4.6	4.7	4.4	4.1	3.9	3.6	3.3
54.0	6.6	5.4	4.8	6.7	5.7	4.9	4.9	4.5	4.3	4.1	3.9	3.8	3.3	3.2	3.0
58.0	6.0	5.1	4.8	5.7	5.4	4.8	4.4	4.1	3.9	3.6	3.4	3.3	2.8	2.7	2.7
62.0	5.2	4.9		4.8	5.1	4.7	4.0	3.7	3.5	3.2	3.0	2.9	2.3	2.3	2.4
66.0	4.5	4.7		4.1	4.4		3.6	3.3	3.2	2.8	2.6	2.6	1.9	1.9	2.0
70.0				3.4	3.6		3.2	3.0		2.4	2.3	2.3	1.5	1.6	1.7
74.0				2.0			2.6	2.8		2.1	2.0				
78.0							2.1			1.8	1.7				
82.0										1.6	1.5				
θ (°)	21~ 83	29~ 84.5	49~ 84.5	11~ 83	31~ 84.5	49~ 84.5	15~ 83	32~ 84.5	49~ 84.5	19~ 83	26~ 84.5	49~ 84.5	42~ 83	49~ 84.5	53~ 84.5
標準フック	35t												12.2t		
フック重量	950kg												440kg		
標準巻掛本数	2												1		

カウンタウエイト 118t、アウトリガ張出幅 8.5m、または 8.0m
 ブーム+2.0m+35.5m油圧チルトジブ

単位:t

ブーム長さ(m) 作業半径 (m)	40.4			45.4			50.5			55.6			60.0		
	オフセット			オフセット			オフセット			オフセット			オフセット		
	0°	20°	40°	0°	20°	40°	0°	20°	40°	0°	20°	40°	0°	20°	40°
14.0	17.2														
16.0	16.2			15.1											
18.0	15.3			14.3			12.9								
20.0	14.5			13.6			12.0			10.6					
22.0	13.7			12.9			11.1			9.8			9.4		
24.0	12.8			12.3			10.4			9.2			8.7		
26.0	12.0	7.9		11.7			9.8			8.6			8.2		
28.0	11.3	7.5		11.1	7.7		9.2			8.0			7.7		
30.0	10.7	7.1		10.6	7.3		8.7	6.8		7.5			7.2		
32.0	10.1	6.7		10.1	6.9		8.2	6.5		7.1	5.8		6.8	5.4	
34.0	9.6	6.4		9.7	6.6		7.8	6.2		6.7	5.6		6.4	5.0	
36.0	8.9	6.1	4.5	9.2	6.3		7.4	5.9		6.4	5.3		6.1	4.7	
38.0	8.4	5.8	4.3	8.8	6.0	4.4	7.0	5.7		6.0	5.0		5.8	4.4	
40.0	7.9	5.5	4.2	8.4	5.7	4.2	6.7	5.5	4.5	5.7	4.8		5.3	4.1	
42.0	7.4	5.3	4.0	8.0	5.5	4.1	6.3	5.2	4.4	5.5	4.6	4.1	4.9	3.9	3.3
44.0	7.0	5.0	3.9	7.5	5.3	4.0	6.0	5.0	4.3	5.2	4.4	3.9	4.5	3.6	3.1
46.0	6.6	4.8	3.8	7.1	5.0	3.9	5.7	4.8	4.1	4.8	4.2	3.7	4.1	3.4	2.9
48.0	6.2	4.6	3.7	6.7	4.8	3.7	5.4	4.7	4.0	4.5	4.0	3.5	3.7	3.2	2.7
50.0	5.9	4.4	3.6	6.4	4.7	3.7	5.1	4.5	3.9	4.1	3.8	3.3	3.4	3.0	2.6
54.0	5.3	4.1	3.4	5.8	4.3	3.5	4.5	4.1	3.7	3.6	3.4	3.0	2.8	2.6	2.3
58.0	4.8	3.8	3.3	5.2	4.0	3.3	3.9	3.6	3.4	3.0	2.9	2.7	2.3	2.3	2.0
62.0	4.3	3.6	3.2	4.7	3.8	3.2	3.5	3.2	3.0	2.6	2.5	2.4	1.9	1.9	1.8
66.0	4.0	3.4	3.2	4.0	3.6	3.2	3.1	2.8	2.7	2.2	2.1	2.1	1.5	1.6	1.6
70.0	3.6	3.3		3.3	3.4	3.2	2.7	2.5	2.4	1.9	1.8	1.8			
74.0	3.2			2.7	3.0		2.4	2.2	2.1	1.5	1.5	1.5			
78.0				2.2	2.4		2.1	2.0							
82.0							1.6	1.8							
θ (°)	14~ 83	34~ 84.5	46~ 84.5	18~ 83	26~ 84.5	47~ 84.5	21~ 83	29~ 84.5	47~ 84.5	39~ 83	48~ 84.5	53~ 84.5	50~ 83	58~ 84.5	63~ 84.5
標準フック	35t												12.2t		
フック重量	950kg												440kg		
標準巻掛本数	2												1		

油圧チルトジブ

カウンタウエイト 118t、アウトリガ張出幅 8.5m、または 8.0m
 ブーム+2.0m+41.5m油圧チルトジブ

単位:t

ブーム長さ(m) 作業半径 (m)	40.4			45.4			50.5			55.6			60.0		
	オフセット			オフセット			オフセット			オフセット			オフセット		
	0°	20°	40°	0°	20°	40°	0°	20°	40°	0°	20°	40°	0°	20°	40°
16.0	13.4			12.3											
18.0	12.7			11.7			10.5								
20.0	12.0			11.1			10.0					8.9			
22.0	11.3			10.5			9.6				8.6				
24.0	10.6			10.0			9.2				8.2			7.7	
26.0	10.0			9.5			8.8				7.7			7.3	
28.0	9.3			9.1			8.2				7.2			6.8	
30.0	8.8	5.8		8.7			7.7				6.7			6.4	
32.0	8.3	5.4		8.3	5.6		7.3				6.3			6.0	
34.0	7.8	5.1		7.9	5.3		6.9	5.4			5.9			5.6	
36.0	7.4	4.8		7.5	5.0		6.5	5.1			5.6	4.6		5.1	3.7
38.0	7.0	4.5		7.1	4.7		6.1	4.9			5.3	4.3		4.7	3.4
40.0	6.5	4.2		6.7	4.4		5.8	4.6			5.0	4.0		4.3	3.1
42.0	6.1	4.0	2.8	6.4	4.2		5.5	4.4			4.6	3.7		3.9	2.9
44.0	5.7	3.8	2.6	6.1	4.0	2.7	5.1	4.1			4.2	3.4		3.6	2.7
46.0	5.3	3.6	2.5	5.8	3.8	2.6	4.8	3.9	2.6		3.8	3.2		3.3	2.5
48.0	4.9	3.4	2.4	5.4	3.6	2.5	4.4	3.7	2.5	3.5	3.0	2.5	2.5	2.9	2.3
50.0	4.6	3.2	2.3	5.1	3.4	2.4	4.1	3.5	2.4	3.2	2.7	2.3	2.6	2.6	1.7
54.0	4.1	2.9	2.1	4.5	3.1	2.2	3.5	3.1	2.3	2.6	2.4	2.0	2.1	2.1	1.7
58.0	3.6	2.6	2.0	4.0	2.8	2.0	3.0	2.7	2.1	2.1	2.0	1.7	1.6		
62.0	3.2	2.3	1.8	3.5	2.5	1.9	2.5	2.3	2.0	1.7	1.6				
66.0	2.8	2.1	1.7	3.1	2.3	1.8	2.1	1.9	1.8						
70.0	2.5	1.9	1.7	2.8	2.1	1.7	1.8	1.6	1.5						
74.0	2.2	1.8		2.4	1.9	1.7									
78.0	1.9	1.7		1.9	1.8										
82.0				1.7											
θ (°)	20~ 83	30~ 84.5	51~ 84.5	29~ 83	32~ 84.5	51~ 84.5	44~ 83	54~ 84.5	60~ 84.5	54~ 83	63~ 84.5	73~ 84.5	59~ 83	70~ 84.5	80~ 84.5
標準フック	35t						12.2t								
フック重量	950kg						440kg								
標準巻掛本数	2						1								

カウンタウエイト 118t、アウトリガ張出幅 8.5m、または 8.0m
 ブーム+2.0m+47.5m油圧チルトジブ

単位:t

ブーム長さ(m) 作業半径 (m)	40.4		45.4		50.5		55.6		60.0	
	オフセット		オフセット		オフセット		オフセット		オフセット	
	0°	20°	0°	20°	0°	20°	0°	20°	0°	20°
16.0	10.7									
18.0	10.1		9.3							
20.0	9.6		8.8		7.8					
22.0	9.0		8.3		7.5		6.5			
24.0	8.5		7.9		7.1		6.3			
26.0	8.1		7.5		6.8		6.0		5.6	
28.0	7.6		7.1		6.5		5.8		5.4	
30.0	7.2		6.8		6.2		5.6		5.2	
32.0	6.7		6.5		5.9		5.3		4.9	
34.0	6.3	3.7	6.2		5.6		5.1		4.7	
36.0	5.9	3.5	5.9	3.6	5.4		4.9		4.2	
38.0	5.4	3.2	5.6	3.4	5.2	3.5	4.6		3.8	
40.0	5.0	3.0	5.3	3.1	4.9	3.3	4.2	3.1	3.5	
42.0	4.6	2.8	5.0	2.9	4.7	3.1	3.8	2.8	3.1	2.1
44.0	4.3	2.6	4.7	2.7	4.4	2.9	3.5	2.6	2.8	1.9
46.0	4.0	2.4	4.3	2.6	4.0	2.7	3.2	2.4	2.5	1.7
48.0	3.7	2.3	4.0	2.4	3.6	2.5	2.8	2.1	2.2	1.5
50.0	3.4	2.1	3.7	2.2	3.3	2.4	2.5	1.9	2.0	
54.0	2.9	1.8	3.2	1.9	2.7	2.1	2.0	1.5	1.5	
58.0	2.5	1.6	2.8	1.7	2.2	1.8	1.5			
62.0	2.1		2.4	1.5	1.8	1.6				
66.0	1.8		2.1							
70.0	1.5		1.8							
74.0			1.5							
θ (°)	40~ 84.5	62~ 84.5	40~ 84.5	62~ 84.5	54~ 84.5	65~ 84.5	60~ 84.5	72~ 84.5	64~ 84.5	77~ 84.5
標準フック	12.2t									
フック重量	440kg									
標準巻掛本数	1									

カウンタウエイト 98t、アウトリガ張出幅 8.5m

ブーム+2.0m+3.5m油圧チルトジブ

単位:t

ブーム長さ(m) 作業半径 (m)	40.4			45.4			50.5			55.6			60.0		
	オフセット			オフセット			オフセット			オフセット			オフセット		
	0°	20°	40°	0°	20°	40°	0°	20°	40°	0°	20°	40°	0°	20°	40°
8.0	47.7			38.0											
9.0	44.9	42.5													
10.0	42.5	40.3	38.9	36.1	33.9			28.4							
11.0	40.3	38.4	37.1	34.4	32.4	31.1	27.0	25.5		23.9					
12.0	38.3	36.6	35.5	32.9	31.1	29.9	25.7	24.4	23.5	22.8	21.5				
14.0	35.0	33.6	32.7	30.3	28.8	27.8	23.6	22.5	21.7	20.8	19.9	19.2	19.7		
16.0	32.2	31.0	30.3	28.1	26.8	26.0	21.8	20.9	20.3	19.2	18.5	18.0	18.2	17.5	17.1
18.0	29.9	28.9	28.3	26.0	25.1	24.4	20.3	19.5	19.0	17.8	17.2	16.8	16.9	16.3	15.9
20.0	27.9	27.0	26.5	24.2	23.6	23.1	19.0	18.3	17.9	16.6	16.1	15.8	15.7	15.2	14.9
22.0	26.1	25.4	25.0	22.6	22.1	21.8	17.9	17.3	16.9	15.6	15.1	14.8	14.7	14.3	14.1
24.0	24.6	24.0	23.7	21.3	20.8	20.6	16.9	16.3	16.0	14.7	14.3	14.0	13.9	13.5	13.3
26.0	23.3	22.8	22.5	20.0	19.7	19.5	16.0	15.5	15.2	13.9	13.5	13.3	13.1	12.8	12.6
28.0	21.9	21.7	21.5	19.0	18.6	18.5	15.2	14.8	14.6	13.1	12.8	12.6	12.4	12.1	12.0
30.0	20.0	20.1	20.2	18.0	17.7	17.6	14.5	14.1	13.9	12.5	12.2	12.1	11.8	11.5	11.4
32.0	18.3	18.4	18.4	17.2	16.9	16.8	13.9	13.6	13.4	11.9	11.7	11.5	11.2	11.0	10.9
34.0	16.8	16.9	16.9	16.3	16.2	16.1	13.3	13.0	12.9	11.4	11.2	11.0	10.7	10.5	10.4
36.0	15.4	15.5		14.9	15.0	15.0	12.8	12.6	12.4	10.9	10.7	10.6	10.3	10.1	10.0
38.0	14.2	14.3		13.7	13.8	13.8	12.4	12.1	12.0	10.5	10.3	10.2	9.8	9.7	9.6
40.0	13.1	13.1		12.6	12.7		12.0	11.7	11.7	10.1	9.9	9.9	9.5	9.3	9.2
42.0	12.1			11.7	11.7		11.6	11.4	11.4	9.7	9.6	9.5	9.1	9.0	8.9
44.0	5.6			10.8	10.8		10.8	10.8		9.4	9.3	9.2	8.8	8.7	8.6
46.0				10.0	10.0		10.0	10.0		9.1	9.0	9.0	8.5	8.4	8.3
48.0				9.0			9.3	9.3		8.8	8.7		8.2	8.1	8.1
50.0							8.6	8.6		8.6	8.5		8.0	7.9	
54.0							4.1			7.4	7.5		7.1	7.2	
58.0										6.4			6.1	6.1	
62.0													5.2		
θ(°)	0~ 84.5	27~ 84.5	43~ 84.5	13~ 84.5	23~ 84.5	42~ 84.5	0~ 84.5	25~ 84.5	42~ 84.5	13~ 84.5	27~ 84.5	42~ 84.5	15~ 84.5	27~ 84.5	45~ 84.5
標準フック	80t						35t								
フック重量	1550kg						950kg								
標準巻掛本数	5						3								

カウンタウエイト 98t、アウトリガ張出幅 8.5m

ブーム+2.0m+11.5m油圧チルトジブ

単位:t

ブーム長さ(m) 作業半径 (m)	40.4			45.4			50.5			55.6			60.0		
	オフセット			オフセット			オフセット			オフセット			オフセット		
	0°	20°	40°	0°	20°	40°	0°	20°	40°	0°	20°	40°	0°	20°	40°
10.0	38.8														
11.0	36.7			31.1											
12.0	34.8			29.6			23.3								
14.0	31.5	27.6		27.0	23.4		21.2			18.8					
16.0	28.9	26.1	22.7	24.8	21.8		19.4	16.7		17.4	14.9		15.6		
18.0	26.6	24.2	21.8	23.0	20.4	18.8	18.0	15.8	14.0	16.0	14.0		15.1		
20.0	24.7	22.6	21.0	21.5	19.2	17.8	16.7	15.0	13.4	14.9	13.2	12.0	14.0	12.5	
22.0	23.0	21.3	20.1	20.1	18.1	16.9	15.6	14.1	12.8	13.9	12.5	11.4	13.1	11.9	
24.0	21.6	20.0	19.0	18.9	17.2	16.1	14.7	13.3	12.3	13.0	11.9	10.9	12.3	11.3	10.4
26.0	20.3	18.9	18.1	17.9	16.3	15.3	13.8	12.6	11.9	12.2	11.3	10.5	11.5	10.7	9.9
28.0	19.2	18.0	17.2	17.0	15.5	14.7	13.1	12.0	11.4	11.5	10.8	10.0	10.9	10.2	9.5
30.0	18.2	17.1	16.4	16.1	14.9	14.1	12.4	11.4	10.9	10.9	10.2	9.7	10.3	9.7	9.2
32.0	17.3	16.3	15.7	15.2	14.2	13.5	11.8	10.9	10.4	10.3	9.7	9.3	9.7	9.2	8.8
34.0	16.4	15.6	15.1	14.5	13.7	13.1	11.2	10.4	10.0	9.8	9.3	8.9	9.3	8.7	8.4
36.0	15.1	15.0	14.5	13.8	13.2	12.6	10.7	10.0	9.6	9.4	8.9	8.5	8.8	8.4	8.1
38.0	13.9	14.2	14.0	13.2	12.7	12.2	10.3	9.6	9.3	9.0	8.5	8.2	8.4	8.0	7.7
40.0	12.8	13.1	13.3	12.5	12.1	11.8	9.9	9.3	8.9	8.6	8.1	7.9	8.0	7.7	7.4
42.0	11.9	12.1	12.2	11.5	11.7	11.5	9.5	8.9	8.6	8.2	7.8	7.6	7.7	7.3	7.1
44.0	11.0	11.2		10.6	10.9	11.1	9.1	8.6	8.4	7.9	7.5	7.3	7.4	7.1	6.9
46.0	10.2	10.4		9.8	10.1	10.2	8.8	8.4	8.1	7.6	7.3	7.1	7.1	6.8	6.6
48.0	9.5	9.6		9.1	9.3		8.5	8.1	7.9	7.3	7.0	6.8	6.8	6.6	6.4
50.0	8.8			8.4	8.6		8.3	7.9	7.7	7.1	6.8	6.6	6.5	6.3	6.2
54.0				7.3	7.4		7.1	7.3		6.6	6.4	6.3	5.7	5.6	5.6
58.0							6.1	6.3		6.1	6.0		5.1	5.0	
62.0							2.0			5.3	5.4		4.5	4.5	
66.0										4.0			4.0	4.0	
70.0													3.5		
θ(°)	17~ 83	28~ 84.5	44~ 84.5	20~ 83	24~ 84.5	44~ 84.5	0~ 83	26~ 84.5	43~ 84.5	12~ 83	28~ 84.5	43~ 84.5	14~ 83	28~ 84.5	48~ 84.5
標準フック	80t						35t								
フック重量	1550kg						950kg								
標準巻掛本数	4						3								

油圧チルトジブ

カウンタウエイト 98t、アウトリガ張出幅 8.5m

ブーム+2.0m+17.5m油圧チルトジブ

単位:t

ブーム長さ(m) 作業半径 (m)	40.4			45.4			50.5			55.6			60.0		
	オフセット			オフセット			オフセット			オフセット			オフセット		
	0°	20°	40°	0°	20°	40°	0°	20°	40°	0°	20°	40°	0°	20°	40°
11.0	31.5														
12.0	30.3			27.0											
14.0	28.1			24.6			19.5								
16.0	26.3	20.6		22.6			17.9			15.6			14.8		
18.0	24.6	19.5		20.8	17.9		16.5	13.4		14.5			13.7		
20.0	22.8	18.6		19.4	16.8		15.3	12.7		13.5	11.3		12.8		
22.0	21.2	17.8	14.0	18.1	15.8		14.3	12.0		12.6	10.7		12.0	10.2	
24.0	19.9	17.1	13.6	17.0	15.0	13.7	13.4	11.5	10.1	11.9	10.1		11.2	9.6	
26.0	18.6	16.4	13.3	16.0	14.2	13.1	12.5	11.0	9.7	11.1	9.6	8.7	10.5	9.2	8.3
28.0	17.6	15.8	12.9	15.1	13.5	12.5	11.8	10.5	9.3	10.5	9.2	8.3	9.9	8.7	7.9
30.0	16.6	15.3	12.7	14.4	12.9	12.0	11.2	10.1	9.0	9.9	8.8	8.0	9.3	8.4	7.6
32.0	15.7	14.6	12.4	13.6	12.3	11.5	10.6	9.6	8.7	9.3	8.4	7.7	8.8	8.0	7.3
34.0	15.0	13.9	12.2	13.0	11.8	11.1	10.1	9.2	8.5	8.8	8.1	7.4	8.3	7.7	7.1
36.0	14.3	13.3	12.0	12.4	11.3	10.6	9.6	8.8	8.2	8.4	7.7	7.1	7.9	7.4	6.8
38.0	13.6	12.8	11.8	11.9	10.9	10.3	9.2	8.4	8.0	8.0	7.4	6.9	7.5	7.0	6.6
40.0	12.7	12.3	11.7	11.4	10.5	9.9	8.8	8.1	7.7	7.6	7.1	6.7	7.2	6.7	6.4
42.0	11.7	11.8	11.4	11.0	10.1	9.6	8.4	7.8	7.4	7.3	6.8	6.5	6.9	6.4	6.2
44.0	10.9	11.2	11.1	10.4	9.8	9.3	8.0	7.5	7.1	7.0	6.5	6.3	6.5	6.2	6.0
46.0	10.1	10.4	10.6	9.6	9.5	9.1	7.7	7.2	6.9	6.7	6.3	6.1	6.3	5.9	5.7
48.0	9.3	9.6	9.8	8.9	9.2	8.8	7.5	7.0	6.7	6.4	6.0	5.9	5.9	5.6	5.5
50.0	8.7	8.9		8.2	8.6	8.6	7.2	6.7	6.5	6.2	5.8	5.6	5.5	5.3	5.3
54.0	7.5	7.7		7.1	7.3		6.7	6.3	6.1	5.7	5.4	5.3	4.8	4.7	4.7
58.0				6.1	6.2		6.0	6.0		5.3	5.1	5.0	4.2	4.1	4.2
62.0				4.5			5.1	5.3		4.8	4.7		3.6	3.6	3.7
66.0							4.4			4.3	4.3		3.2	3.2	
70.0										3.6	3.7		2.8	2.8	
74.0													2.5	2.5	
θ(°)	23~ 83	28~ 84.5	44~ 84.5	11~ 83	30~ 84.5	48~ 84.5	16~ 83	31~ 84.5	47~ 84.5	19~ 83	23~ 84.5	47~ 84.5	20~ 83	24~ 84.5	46~ 84.5
標準フック	35t						35t								
フック重量	950kg						950kg								
標準巻掛本数	3						2								

カウンタウエイト 98t、アウトリガ張出幅 8.5m

ブーム+2.0m+23.5m油圧チルトジブ

単位:t

ブーム長さ(m) 作業半径 (m)	40.4			45.4			50.5			55.6			60.0		
	オフセット			オフセット			オフセット			オフセット			オフセット		
	0°	20°	40°	0°	20°	40°	0°	20°	40°	0°	20°	40°	0°	20°	40°
12.0	25.7														
14.0	23.9			22.1			17.6								
16.0	22.2			20.7			16.2			14.2					
18.0	20.8			19.3			15.0			13.1			12.4		
20.0	19.6	14.4		17.9			14.0			12.2			11.6		
22.0	18.5	13.6		16.7	13.8		13.1	10.3		11.4			10.8		
24.0	17.5	12.9		15.6	13.2		12.2	9.8		10.6	8.8		10.1		
26.0	16.6	12.3	9.3	14.7	12.6		11.4	9.4		10.0	8.3		9.5	8.0	
28.0	15.8	11.7	9.0	13.8	12.1	9.1	10.7	9.0		9.4	7.9		9.0	7.6	
30.0	15.1	11.2	8.7	13.1	11.5	8.9	10.1	8.6	7.5	8.9	7.6	6.7	8.5	7.2	
32.0	14.5	10.7	8.5	12.4	11.0	8.6	9.6	8.2	7.2	8.5	7.2	6.5	8.0	6.9	6.2
34.0	13.9	10.3	8.3	11.8	10.5	8.4	9.1	7.9	7.0	8.0	6.9	6.2	7.6	6.6	6.0
36.0	13.2	9.9	8.1	11.2	10.0	8.2	8.6	7.6	6.8	7.6	6.6	6.0	7.2	6.3	5.7
38.0	12.6	9.6	7.9	10.7	9.6	8.1	8.2	7.3	6.5	7.2	6.4	5.8	6.8	6.1	5.5
40.0	12.0	9.2	7.7	10.2	9.2	7.9	7.8	7.1	6.3	6.9	6.1	5.6	6.5	5.8	5.3
42.0	11.4	8.9	7.6	9.8	8.9	7.7	7.5	6.8	6.2	6.5	5.9	5.4	6.1	5.6	5.1
44.0	10.7	8.6	7.5	9.4	8.6	7.6	7.1	6.5	6.0	6.2	5.7	5.2	5.8	5.4	4.9
46.0	9.9	8.4	7.4	9.1	8.3	7.5	6.8	6.3	5.8	5.9	5.5	5.0	5.4	5.1	4.7
48.0	9.2	8.1	7.3	8.7	8.0	7.4	6.6	6.0	5.7	5.7	5.3	4.9	5.0	4.8	4.5
50.0	8.5	7.9	7.2	8.1	7.7	7.3	6.3	5.8	5.5	5.4	5.1	4.7	4.6	4.4	4.3
54.0	7.4	7.6	7.2	6.9	7.3	6.9	5.8	5.4	5.2	4.8	4.6	4.4	4.0	3.9	3.9
58.0	6.3	6.6		5.9	6.3	6.5	5.4	5.1	4.9	4.3	4.1	4.0	3.4	3.4	3.4
62.0	5.5			5.1	5.3		4.9	4.7	4.5	3.8	3.7	3.6	2.9	2.9	3.0
66.0				4.3	4.5		4.1	4.3		3.5	3.3	3.3	2.5	2.5	2.6
70.0							3.5	3.7		3.1	3.0		2.1	2.1	
74.0										2.8	2.8		1.8	1.8	
78.0										1.8			1.5	1.6	
θ(°)	16~ 83	33~ 84.5	45~ 84.5	19~ 83	25~ 84.5	45~ 84.5	21~ 83	27~ 84.5	45~ 84.5	12~ 83	29~ 84.5	45~ 84.5	24~ 83	30~ 84.5	50~ 84.5
標準フック	35t						35t								
フック重量	950kg						950kg								
標準巻掛本数	3						2								

カウンタウエイト 98t、アウトリガ張出幅 8.5m

ブーム+2.0m+29.5m油圧チルトジブ

単位:t

ブーム長さ(m) 作業半径 (m)	40.4			45.4			50.5			55.6			60.0		
	オフセット			オフセット			オフセット			オフセット			オフセット		
	0°	20°	40°	0°	20°	40°	0°	20°	40°	0°	20°	40°	0°	20°	40°
14.0	20.4			18.9											
16.0	19.0			17.7			14.7								
18.0	17.8			16.7			13.6			12.4					
20.0	16.7			15.7			12.6			11.4			10.9		
22.0	15.8			14.9			11.7			10.6			10.1		
24.0	14.9	10.2		14.1	10.5		11.0			9.9			9.5		
26.0	14.1	9.6		13.4	9.9		10.3	8.2		9.3			8.9		
28.0	13.4	9.1		12.7	9.4		9.8	7.8		8.7	7.2		8.3		
30.0	12.8	8.7		11.9	9.0		9.2	7.4		8.2	6.8		7.9	6.5	
32.0	12.2	8.3	6.2	11.3	8.6	6.3	8.7	7.1		7.8	6.5		7.4	6.2	
34.0	11.4	7.9	6.0	10.7	8.2	6.1	8.2	6.8	5.9	7.4	6.2		7.0	5.9	
36.0	10.7	7.6	5.9	10.2	7.9	6.0	7.8	6.5	5.7	7.0	5.9	5.3	6.7	5.5	
38.0	10.0	7.2	5.7	9.7	7.5	5.8	7.4	6.3	5.5	6.7	5.7	5.1	6.3	5.2	4.4
40.0	9.5	6.9	5.5	9.2	7.2	5.6	7.0	6.0	5.3	6.4	5.4	4.9	5.9	4.9	4.2
42.0	8.9	6.7	5.4	8.8	7.0	5.5	6.7	5.8	5.1	6.0	5.2	4.7	5.4	4.6	4.0
44.0	8.5	6.4	5.3	8.4	6.7	5.4	6.4	5.6	5.0	5.7	5.0	4.5	5.0	4.3	3.8
46.0	8.0	6.2	5.1	8.1	6.5	5.2	6.1	5.4	4.8	5.4	4.8	4.3	4.6	4.1	3.6
48.0	7.6	6.0	5.0	7.7	6.3	5.1	5.8	5.2	4.7	5.1	4.6	4.2	4.2	3.9	3.4
50.0	7.2	5.8	5.0	7.4	6.1	5.0	5.5	5.1	4.6	4.7	4.4	4.1	3.9	3.6	3.3
54.0	6.6	5.4	4.8	6.7	5.7	4.9	4.9	4.5	4.3	4.1	3.9	3.8	3.3	3.2	3.0
58.0	6.0	5.1	4.8	5.7	5.4	4.8	4.4	4.1	3.9	3.6	3.4	3.3	2.8	2.7	2.7
62.0	5.2	4.9		4.8	5.1	4.7	4.0	3.7	3.5	3.2	3.0	2.9	2.3	2.3	2.4
66.0	4.5	4.7		4.1	4.4		3.6	3.3	3.2	2.8	2.6	2.6	1.9	1.9	2.0
70.0				3.4	3.6		3.2	3.0		2.4	2.3	2.3	1.5	1.6	1.7
74.0				2.0			2.6	2.8		2.1	2.0				
78.0							2.0			1.8	1.7				
82.0										1.5	1.5				
θ (°)	21~ 83	29~ 84.5	49~ 84.5	11~ 83	31~ 84.5	49~ 84.5	15~ 83	32~ 84.5	49~ 84.5	19~ 83	26~ 84.5	49~ 84.5	42~ 83	49~ 84.5	53~ 84.5
標準フック	35t												12.2t		
フック重量	950kg												440kg		
標準巻掛本数	2												1		

カウンタウエイト 98t、アウトリガ張出幅 8.5m

ブーム+2.0m+35.5m油圧チルトジブ

単位:t

ブーム長さ(m) 作業半径 (m)	40.4			45.4			50.5			55.6			60.0		
	オフセット			オフセット			オフセット			オフセット			オフセット		
	0°	20°	40°	0°	20°	40°	0°	20°	40°	0°	20°	40°	0°	20°	40°
14.0	17.2														
16.0	16.2			15.1											
18.0	15.3			14.3			12.9								
20.0	14.5			13.6			12.0			10.6					
22.0	13.7			12.9			11.1			9.8			9.4		
24.0	12.8			12.3			10.4			9.2			8.7		
26.0	12.0	7.9		11.7			9.8			8.6			8.2		
28.0	11.3	7.5		11.1	7.7		9.2			8.0			7.7		
30.0	10.7	7.1		10.6	7.3		8.7	6.8		7.5			7.2		
32.0	10.1	6.7		10.1	6.9		8.2	6.5		7.1	5.8		6.8	5.4	
34.0	9.6	6.4		9.7	6.6		7.8	6.2		6.7	5.6		6.4	5.0	
36.0	8.9	6.1	4.5	9.2	6.3		7.4	5.9		6.4	5.3		6.1	4.7	
38.0	8.4	5.8	4.3	8.8	6.0	4.4	7.0	5.7		6.0	5.0		5.8	4.4	
40.0	7.9	5.5	4.2	8.4	5.7	4.2	6.7	5.5	4.5	5.7	4.8		5.3	4.1	
42.0	7.4	5.3	4.0	8.0	5.5	4.1	6.3	5.2	4.4	5.5	4.6	4.1	4.9	3.9	3.3
44.0	7.0	5.0	3.9	7.5	5.3	4.0	6.0	5.0	4.3	5.2	4.4	3.9	4.5	3.6	3.1
46.0	6.6	4.8	3.8	7.1	5.0	3.9	5.7	4.8	4.1	4.8	4.2	3.7	4.1	3.4	2.9
48.0	6.2	4.6	3.7	6.7	4.8	3.7	5.4	4.7	4.0	4.5	4.0	3.5	3.7	3.2	2.7
50.0	5.9	4.4	3.6	6.4	4.7	3.7	5.1	4.5	3.9	4.1	3.8	3.3	3.4	3.0	2.6
54.0	5.3	4.1	3.4	5.8	4.3	3.5	4.5	4.1	3.7	3.6	3.4	3.0	2.8	2.6	2.3
58.0	4.8	3.8	3.3	5.2	4.0	3.3	3.9	3.6	3.4	3.0	2.9	2.7	2.3	2.3	2.0
62.0	4.3	3.6	3.2	4.7	3.8	3.2	3.5	3.2	3.0	2.6	2.5	2.4	1.9	1.9	1.8
66.0	4.0	3.4	3.2	4.0	3.6	3.2	3.1	2.8	2.7	2.2	2.1	2.1	1.5	1.6	1.6
70.0	3.6	3.3		3.3	3.4	3.2	2.7	2.5	2.4	1.9	1.8	1.8			
74.0	3.1			2.7	3.0		2.4	2.2	2.1	1.5	1.5	1.5			
78.0				2.1	2.4		2.1	2.0							
82.0							1.5	1.8							
θ (°)	14~ 83	34~ 84.5	46~ 84.5	18~ 83	26~ 84.5	47~ 84.5	21~ 83	29~ 84.5	47~ 84.5	39~ 83	48~ 84.5	53~ 84.5	50~ 83	58~ 84.5	63~ 84.5
標準フック	35t												12.2t		
フック重量	950kg												440kg		
標準巻掛本数	2												1		

油圧チルトジブ

カウンタウエイト 98t、アウトリガ張出幅 8.5m

ブーム+2.0m+41.5m油圧チルトジブ

単位:t

ブーム長さ(m) 作業半径 (m)	40.4			45.4			50.5			55.6			60.0		
	オフセット			オフセット			オフセット			オフセット			オフセット		
	0°	20°	40°	0°	20°	40°	0°	20°	40°	0°	20°	40°	0°	20°	40°
16.0	13.4			12.3											
18.0	12.7			11.7			10.5								
20.0	12.0			11.1			10.0					8.9			
22.0	11.3			10.5			9.6				8.6				
24.0	10.6			10.0			9.2				8.2			7.7	
26.0	10.0			9.5			8.8				7.7			7.3	
28.0	9.3			9.1			8.2				7.2			6.8	
30.0	8.8	5.8		8.7			7.7				6.7			6.4	
32.0	8.3	5.4		8.3	5.6		7.3				6.3			6.0	
34.0	7.8	5.1		7.9	5.3		6.9	5.4			5.9			5.6	
36.0	7.4	4.8		7.5	5.0		6.5	5.1			5.6	4.6		5.1	3.7
38.0	7.0	4.5		7.1	4.7		6.1	4.9			5.3	4.3		4.7	3.4
40.0	6.5	4.2		6.7	4.4		5.8	4.6			5.0	4.0		4.3	3.1
42.0	6.1	4.0	2.8	6.4	4.2		5.5	4.4			4.6	3.7		3.9	2.9
44.0	5.7	3.8	2.6	6.1	4.0	2.7	5.1	4.1			4.2	3.4		3.6	2.7
46.0	5.3	3.6	2.5	5.8	3.8	2.6	4.8	3.9	2.6		3.8	3.2		3.3	2.5
48.0	4.9	3.4	2.4	5.4	3.6	2.5	4.4	3.7	2.5	3.5	3.0	2.5	2.5	2.9	2.3
50.0	4.6	3.2	2.3	5.1	3.4	2.4	4.1	3.5	2.4	3.2	2.7	2.3	2.6	2.6	2.1
54.0	4.1	2.9	2.1	4.5	3.1	2.2	3.5	3.1	2.3	2.6	2.4	2.0	2.1	1.7	
58.0	3.6	2.6	2.0	4.0	2.8	2.0	3.0	2.7	2.1	2.1	2.0	1.7	1.6		
62.0	3.2	2.3	1.8	3.5	2.5	1.9	2.5	2.3	2.0	1.7	1.6				
66.0	2.8	2.1	1.7	3.1	2.3	1.8	2.1	1.9	1.8						
70.0	2.5	1.9	1.7	2.8	2.1	1.7	1.8	1.6	1.5						
74.0	2.2	1.8		2.4	1.9	1.7									
78.0	1.9	1.7		1.9	1.8										
82.0				1.7											
θ(°)	20~ 83	30~ 84.5	51~ 84.5	29~ 83	32~ 84.5	51~ 84.5	44~ 83	54~ 84.5	60~ 84.5	54~ 83	63~ 84.5	73~ 84.5	59~ 83	70~ 84.5	80~ 84.5
標準フック	35t						12.2t								
フック重量	950kg						440kg								
標準巻掛本数	2						1								

カウンタウエイト 98t、アウトリガ張出幅 8.5m

ブーム+2.0m+47.5m油圧チルトジブ

単位:t

ブーム長さ(m) 作業半径 (m)	40.4		45.4		50.5		55.6		60.0	
	オフセット		オフセット		オフセット		オフセット		オフセット	
	0°	20°	0°	20°	0°	20°	0°	20°	0°	20°
16.0	10.7									
18.0	10.1		9.3							
20.0	9.6		8.8		7.8					
22.0	9.0		8.3		7.5		6.5			
24.0	8.5		7.9		7.1		6.3			
26.0	8.1		7.5		6.8		6.0		5.6	
28.0	7.6		7.1		6.5		5.8		5.4	
30.0	7.2		6.8		6.2		5.6		5.2	
32.0	6.7		6.5		5.9		5.3		4.9	
34.0	6.3	3.7	6.2		5.6		5.1		4.7	
36.0	5.9	3.5	5.9	3.6	5.4		4.9		4.2	
38.0	5.4	3.2	5.6	3.4	5.2	3.5	4.6		3.8	
40.0	5.0	3.0	5.3	3.1	4.9	3.3	4.2	3.1	3.5	
42.0	4.6	2.8	5.0	2.9	4.7	3.1	3.8	2.8	3.1	2.1
44.0	4.3	2.6	4.7	2.7	4.4	2.9	3.5	2.6	2.8	1.9
46.0	4.0	2.4	4.3	2.6	4.0	2.7	3.2	2.4	2.5	1.7
48.0	3.7	2.3	4.0	2.4	3.6	2.5	2.8	2.1	2.2	1.5
50.0	3.4	2.1	3.7	2.2	3.3	2.4	2.5	1.9	2.0	
54.0	2.9	1.8	3.2	1.9	2.7	2.1	2.0	1.5	1.5	
58.0	2.5	1.6	2.8	1.7	2.2	1.8	1.5			
62.0	2.1		2.4	1.5	1.8	1.6				
66.0	1.8		2.1							
70.0	1.5		1.8							
74.0			1.5							
θ(°)	40~ 84.5	62~ 84.5	40~ 84.5	62~ 84.5	54~ 84.5	65~ 84.5	60~ 84.5	72~ 84.5	64~ 84.5	77~ 84.5
標準フック	12.2t									
フック重量	440kg									
標準巻掛本数	1									

カウンタウエイト 98t、アウトリガ張出幅 8.0m

ブーム+2.0m+3.5m油圧チルトジブ

単位:t

ブーム長さ(m) 作業半径 (m)	40.4			45.4			50.5			55.6			60.0		
	オフセット			オフセット			オフセット			オフセット			オフセット		
	0°	20°	40°	0°	20°	40°	0°	20°	40°	0°	20°	40°	0°	20°	40°
8.0	47.7			38.0											
9.0	44.9	42.5													
10.0	42.5	40.3	38.9	36.1	33.9			28.4							
11.0	40.3	38.4	37.1	34.4	32.4	31.1	27.0	25.5		23.9					
12.0	38.3	36.6	35.5	32.9	31.1	29.9	25.7	24.4	23.5	22.8	21.5				
14.0	35.0	33.6	32.7	30.3	28.8	27.8	23.6	22.5	21.7	20.8	19.9	19.2	19.7		
16.0	32.2	31.0	30.3	28.1	26.8	26.0	21.8	20.9	20.3	19.2	18.5	18.0	18.2	17.5	17.1
18.0	29.9	28.9	28.3	26.0	25.1	24.4	20.3	19.5	19.0	17.8	17.2	16.8	16.9	16.3	15.9
20.0	27.9	27.0	26.5	24.2	23.6	23.1	19.0	18.3	17.9	16.6	16.1	15.8	15.7	15.2	14.9
22.0	26.1	25.4	25.0	22.6	22.1	21.8	17.9	17.3	16.9	15.6	15.1	14.8	14.7	14.3	14.1
24.0	24.6	24.0	23.7	21.3	20.8	20.6	16.9	16.3	16.0	14.7	14.3	14.0	13.9	13.5	13.3
26.0	23.3	22.8	22.5	20.0	19.7	19.5	16.0	15.5	15.2	13.9	13.5	13.3	13.1	12.8	12.6
28.0	21.9	21.7	21.5	19.0	18.6	18.5	15.2	14.8	14.6	13.1	12.8	12.6	12.4	12.1	12.0
30.0	20.0	20.1	20.2	18.0	17.7	17.6	14.5	14.1	13.9	12.5	12.2	12.1	11.8	11.5	11.4
32.0	18.3	18.4	18.4	17.2	16.9	16.8	13.9	13.6	13.4	11.9	11.7	11.5	11.2	11.0	10.9
34.0	16.8	16.9	16.9	16.3	16.2	16.1	13.3	13.0	12.9	11.4	11.2	11.0	10.7	10.5	10.4
36.0	15.4	15.5		14.9	15.0	15.0	12.8	12.6	12.4	10.9	10.7	10.6	10.3	10.1	10.0
38.0	14.2	14.3		13.7	13.8	13.8	12.4	12.1	12.0	10.5	10.3	10.2	9.8	9.7	9.6
40.0	13.1	13.1		12.6	12.7		12.0	11.7	11.7	10.1	9.9	9.9	9.5	9.3	9.2
42.0	12.0			11.7	11.7		11.6	11.4	11.4	9.7	9.6	9.5	9.1	9.0	8.9
44.0	5.6			10.8	10.8		10.8	10.8		9.4	9.3	9.2	8.8	8.7	8.6
46.0				10.0	10.0		10.0	10.0		9.1	9.0	9.0	8.5	8.4	8.3
48.0				9.0			9.3	9.3		8.8	8.7		8.2	8.1	8.1
50.0							8.6	8.6		8.6	8.5		8.0	7.9	
54.0							4.1			7.4	7.5		7.1	7.2	
58.0										6.1			6.1	6.1	
62.0													4.9		
θ(°)	0~ 84.5	27~ 84.5	43~ 84.5	13~ 84.5	23~ 84.5	42~ 84.5	0~ 84.5	25~ 84.5	42~ 84.5	13~ 84.5	27~ 84.5	42~ 84.5	15~ 84.5	27~ 84.5	45~ 84.5
標準フック	80t						35t								
フック重量	1550kg						950kg								
標準巻掛本数	5						3								

カウンタウエイト 98t、アウトリガ張出幅 8.0m

ブーム+2.0m+11.5m油圧チルトジブ

単位:t

ブーム長さ(m) 作業半径 (m)	40.4			45.4			50.5			55.6			60.0		
	オフセット			オフセット			オフセット			オフセット			オフセット		
	0°	20°	40°	0°	20°	40°	0°	20°	40°	0°	20°	40°	0°	20°	40°
10.0	38.8														
11.0	36.7			31.1											
12.0	34.8			29.6			23.3								
14.0	31.5	27.6		27.0	23.4		21.2			18.8					
16.0	28.9	26.1	22.7	24.8	21.8		19.4	16.7		17.4	14.9		15.6		
18.0	26.6	24.2	21.8	23.0	20.4	18.8	18.0	15.8	14.0	16.0	14.0		15.1		
20.0	24.7	22.6	21.0	21.5	19.2	17.8	16.7	15.0	13.4	14.9	13.2	12.0	14.0	12.5	
22.0	23.0	21.3	20.1	20.1	18.1	16.9	15.6	14.1	12.8	13.9	12.5	11.4	13.1	11.9	
24.0	21.6	20.0	19.0	18.9	17.2	16.1	14.7	13.3	12.3	13.0	11.9	10.9	12.3	11.3	10.4
26.0	20.3	18.9	18.1	17.9	16.3	15.3	13.8	12.6	11.9	12.2	11.3	10.5	11.5	10.7	9.9
28.0	19.2	18.0	17.2	17.0	15.5	14.7	13.1	12.0	11.4	11.5	10.8	10.0	10.9	10.2	9.5
30.0	18.2	17.1	16.4	16.1	14.9	14.1	12.4	11.4	10.9	10.9	10.2	9.7	10.3	9.7	9.2
32.0	17.3	16.3	15.7	15.2	14.2	13.5	11.8	10.9	10.4	10.3	9.7	9.3	9.7	9.2	8.8
34.0	16.4	15.6	15.1	14.5	13.7	13.1	11.2	10.4	10.0	9.8	9.3	8.9	9.3	8.7	8.4
36.0	15.1	15.0	14.5	13.8	13.2	12.6	10.7	10.0	9.6	9.4	8.9	8.5	8.8	8.4	8.1
38.0	13.9	14.2	14.0	13.2	12.7	12.2	10.3	9.6	9.3	9.0	8.5	8.2	8.4	8.0	7.7
40.0	12.8	13.1	13.3	12.5	12.1	11.8	9.9	9.3	8.9	8.6	8.1	7.9	8.0	7.7	7.4
42.0	11.9	12.1	12.2	11.5	11.7	11.5	9.5	8.9	8.6	8.2	7.8	7.6	7.7	7.3	7.1
44.0	11.0	11.2		10.6	10.9	11.1	9.1	8.6	8.4	7.9	7.5	7.3	7.4	7.1	6.9
46.0	10.2	10.4		9.8	10.1	10.2	8.8	8.4	8.1	7.6	7.3	7.1	7.1	6.8	6.6
48.0	9.5	9.6		9.1	9.3		8.5	8.1	7.9	7.3	7.0	6.8	6.8	6.6	6.4
50.0	8.6			8.4	8.6		8.3	7.9	7.7	7.1	6.8	6.6	6.5	6.3	6.2
54.0				7.1	7.3		7.1	7.3		6.6	6.4	6.3	5.7	5.6	5.6
58.0							6.0	6.2		6.1	6.0		5.1	5.0	
62.0										5.1	5.3		4.5	4.5	
66.0										4.0			3.9	4.0	
70.0													3.0		
θ(°)	17~ 83	28~ 84.5	44~ 84.5	20~ 83	24~ 84.5	44~ 84.5	0~ 83	26~ 84.5	43~ 84.5	12~ 83	28~ 84.5	43~ 84.5	14~ 83	28~ 84.5	48~ 84.5
標準フック	80t						35t								
フック重量	1550kg						950kg								
標準巻掛本数	4						3								

油圧チルトジブ

カウンタウエイト 98t、アウトリガ張出幅 8.0m

ブーム+2.0m+17.5m油圧チルトジブ

単位:t

ブーム長さ(m) 作業半径 (m)	40.4			45.4			50.5			55.6			60.0		
	オフセット			オフセット			オフセット			オフセット			オフセット		
	0°	20°	40°	0°	20°	40°	0°	20°	40°	0°	20°	40°	0°	20°	40°
11.0	31.5														
12.0	30.3			27.0											
14.0	28.1			24.6			19.5								
16.0	26.3	20.6		22.6			17.9			15.6			14.8		
18.0	24.6	19.5		20.8	17.9		16.5	13.4		14.5			13.7		
20.0	22.8	18.6		19.4	16.8		15.3	12.7		13.5	11.3		12.8		
22.0	21.2	17.8	14.0	18.1	15.8		14.3	12.0		12.6	10.7		12.0	10.2	
24.0	19.9	17.1	13.6	17.0	15.0	13.7	13.4	11.5	10.1	11.9	10.1		11.2	9.6	
26.0	18.6	16.4	13.3	16.0	14.2	13.1	12.5	11.0	9.7	11.1	9.6	8.7	10.5	9.2	8.3
28.0	17.6	15.8	12.9	15.1	13.5	12.5	11.8	10.5	9.3	10.5	9.2	8.3	9.9	8.7	7.9
30.0	16.6	15.3	12.7	14.4	12.9	12.0	11.2	10.1	9.0	9.9	8.8	8.0	9.3	8.4	7.6
32.0	15.7	14.6	12.4	13.6	12.3	11.5	10.6	9.6	8.7	9.3	8.4	7.7	8.8	8.0	7.3
34.0	15.0	13.9	12.2	13.0	11.8	11.1	10.1	9.2	8.5	8.8	8.1	7.4	8.3	7.7	7.1
36.0	14.3	13.3	12.0	12.4	11.3	10.6	9.6	8.8	8.2	8.4	7.7	7.1	7.9	7.4	6.8
38.0	13.6	12.8	11.8	11.9	10.9	10.3	9.2	8.4	8.0	8.0	7.4	6.9	7.5	7.0	6.6
40.0	12.7	12.3	11.7	11.4	10.5	9.9	8.8	8.1	7.7	7.6	7.1	6.7	7.2	6.7	6.4
42.0	11.7	11.8	11.4	11.0	10.1	9.6	8.4	7.8	7.4	7.3	6.8	6.5	6.9	6.4	6.2
44.0	10.9	11.2	11.1	10.4	9.8	9.3	8.0	7.5	7.1	7.0	6.5	6.3	6.5	6.2	6.0
46.0	10.1	10.4	10.6	9.6	9.5	9.1	7.7	7.2	6.9	6.7	6.3	6.1	6.3	5.9	5.7
48.0	9.3	9.6	9.8	8.9	9.2	8.8	7.5	7.0	6.7	6.4	6.0	5.9	5.9	5.6	5.5
50.0	8.7	8.9		8.2	8.6	8.6	7.2	6.7	6.5	6.2	5.8	5.6	5.5	5.3	5.3
54.0	7.4	7.7		7.1	7.3		6.7	6.3	6.1	5.7	5.4	5.3	4.8	4.7	4.7
58.0				5.9	6.2		6.0	6.0		5.3	5.1	5.0	4.2	4.1	4.2
62.0				4.5			5.0	5.3		4.8	4.7		3.6	3.6	3.7
66.0							4.0			4.1	4.3		3.2	3.2	
70.0										3.2	3.4		2.8	2.8	
74.0													2.2	2.4	
θ(°)	23~ 83	28~ 84.5	44~ 84.5	11~ 83	30~ 84.5	48~ 84.5	16~ 83	31~ 84.5	47~ 84.5	19~ 83	23~ 84.5	47~ 84.5	20~ 83	24~ 84.5	46~ 84.5
標準フック	35t						35t								
フック重量	950kg						950kg								
標準巻掛本数	3						2								

カウンタウエイト 98t、アウトリガ張出幅 8.0m

ブーム+2.0m+23.5m油圧チルトジブ

単位:t

ブーム長さ(m) 作業半径 (m)	40.4			45.4			50.5			55.6			60.0		
	オフセット			オフセット			オフセット			オフセット			オフセット		
	0°	20°	40°	0°	20°	40°	0°	20°	40°	0°	20°	40°	0°	20°	40°
12.0	25.7														
14.0	23.9			22.1			17.6								
16.0	22.2			20.7			16.2			14.2					
18.0	20.8			19.3			15.0			13.1			12.4		
20.0	19.6	14.4		17.9			14.0			12.2			11.6		
22.0	18.5	13.6		16.7	13.8		13.1	10.3		11.4			10.8		
24.0	17.5	12.9		15.6	13.2		12.2	9.8		10.6	8.8		10.1		
26.0	16.6	12.3	9.3	14.7	12.6		11.4	9.4		10.0	8.3		9.5	8.0	
28.0	15.8	11.7	9.0	13.8	12.1	9.1	10.7	9.0		9.4	7.9		9.0	7.6	
30.0	15.1	11.2	8.7	13.1	11.5	8.9	10.1	8.6	7.5	8.9	7.6	6.7	8.5	7.2	
32.0	14.5	10.7	8.5	12.4	11.0	8.6	9.6	8.2	7.2	8.5	7.2	6.5	8.0	6.9	6.2
34.0	13.9	10.3	8.3	11.8	10.5	8.4	9.1	7.9	7.0	8.0	6.9	6.2	7.6	6.6	6.0
36.0	13.2	9.9	8.1	11.2	10.0	8.2	8.6	7.6	6.8	7.6	6.6	6.0	7.2	6.3	5.7
38.0	12.6	9.6	7.9	10.7	9.6	8.1	8.2	7.3	6.5	7.2	6.4	5.8	6.8	6.1	5.5
40.0	12.0	9.2	7.7	10.2	9.2	7.9	7.8	7.1	6.3	6.9	6.1	5.6	6.5	5.8	5.3
42.0	11.4	8.9	7.6	9.8	8.9	7.7	7.5	6.8	6.2	6.5	5.9	5.4	6.1	5.6	5.1
44.0	10.7	8.6	7.5	9.4	8.6	7.6	7.1	6.5	6.0	6.2	5.7	5.2	5.8	5.4	4.9
46.0	9.9	8.4	7.4	9.1	8.3	7.5	6.8	6.3	5.8	5.9	5.5	5.0	5.4	5.1	4.7
48.0	9.2	8.1	7.3	8.7	8.0	7.4	6.6	6.0	5.7	5.7	5.3	4.9	5.0	4.8	4.5
50.0	8.5	7.9	7.2	8.1	7.7	7.3	6.3	5.8	5.5	5.4	5.1	4.7	4.6	4.4	4.3
54.0	7.4	7.6	7.2	6.9	7.3	6.9	5.8	5.4	5.2	4.8	4.6	4.4	4.0	3.9	3.9
58.0	6.3	6.6		5.9	6.3	6.5	5.4	5.1	4.9	4.3	4.1	4.0	3.4	3.4	3.4
62.0	5.1			5.0	5.3		4.9	4.7	4.5	3.8	3.7	3.6	2.9	2.9	3.0
66.0				3.9	4.2		4.0	4.3		3.5	3.3	3.3	2.5	2.5	2.6
70.0							3.1	3.4		3.1	3.0		2.1	2.1	
74.0										2.4	2.7		1.8	1.8	
78.0										1.7				1.6	
θ(°)	16~ 83	33~ 84.5	45~ 84.5	19~ 83	25~ 84.5	45~ 84.5	21~ 83	27~ 84.5	45~ 84.5	12~ 83	29~ 84.5	45~ 84.5	30~ 83	30~ 84.5	50~ 84.5
標準フック	35t						35t								
フック重量	950kg						950kg								
標準巻掛本数	3						2								

カウンタウエイト 98t、アウトリガ張出幅 8.0m
 ブーム+2.0m+29.5m油圧チルトジブ

単位:t

ブーム長さ(m) 作業半径 (m)	40.4			45.4			50.5			55.6			60.0			
	オフセット			オフセット			オフセット			オフセット			オフセット			
	0°	20°	40°	0°	20°	40°	0°	20°	40°	0°	20°	40°	0°	20°	40°	
14.0	20.4			18.9												
16.0	19.0			17.7			14.7									
18.0	17.8			16.7			13.6									
20.0	16.7			15.7			12.6			11.4				10.9		
22.0	15.8			14.9			11.7			10.6				10.1		
24.0	14.9	10.2		14.1	10.5		11.0			9.9				9.5		
26.0	14.1	9.6		13.4	9.9		10.3	8.2		9.3				8.9		
28.0	13.4	9.1		12.7	9.4		9.8	7.8		8.7	7.2			8.3		
30.0	12.8	8.7		11.9	9.0		9.2	7.4		8.2	6.8			7.9	6.5	
32.0	12.2	8.3	6.2	11.3	8.6	6.3	8.7	7.1		7.8	6.5			7.4	6.2	
34.0	11.4	7.9	6.0	10.7	8.2	6.1	8.2	6.8	5.9	7.4	6.2			7.0	5.9	
36.0	10.7	7.6	5.9	10.2	7.9	6.0	7.8	6.5	5.7	7.0	5.9	5.3		6.7	5.5	
38.0	10.0	7.2	5.7	9.7	7.5	5.8	7.4	6.3	5.5	6.7	5.7	5.1		6.3	5.2	4.4
40.0	9.5	6.9	5.5	9.2	7.2	5.6	7.0	6.0	5.3	6.4	5.4	4.9		5.9	4.9	4.2
42.0	8.9	6.7	5.4	8.8	7.0	5.5	6.7	5.8	5.1	6.0	5.2	4.7		5.4	4.6	4.0
44.0	8.5	6.4	5.3	8.4	6.7	5.4	6.4	5.6	5.0	5.7	5.0	4.5		5.0	4.3	3.8
46.0	8.0	6.2	5.1	8.1	6.5	5.2	6.1	5.4	4.8	5.4	4.8	4.3		4.6	4.1	3.6
48.0	7.6	6.0	5.0	7.7	6.3	5.1	5.8	5.2	4.7	5.1	4.6	4.2		4.2	3.9	3.4
50.0	7.2	5.8	5.0	7.4	6.1	5.0	5.5	5.1	4.6	4.7	4.4	4.1		3.9	3.6	3.3
54.0	6.6	5.4	4.8	6.7	5.7	4.9	4.9	4.5	4.3	4.1	3.9	3.8		3.3	3.2	3.0
58.0	6.0	5.1	4.8	5.7	5.4	4.8	4.4	4.1	3.9	3.6	3.4	3.3		2.8	2.7	2.7
62.0	5.2	4.9		4.8	5.1	4.7	4.0	3.7	3.5	3.2	3.0	2.9		2.3	2.3	2.4
66.0	4.1	4.6		3.9	4.4		3.6	3.3	3.2	2.8	2.6	2.6		1.9	1.9	2.0
70.0				3.0	3.5		3.1	3.0		2.4	2.3	2.3		1.5	1.6	1.7
74.0				2.0			2.3	2.7		2.1	2.0					
78.0							1.6			1.7	1.7					
θ(°)	21~ 83	29~ 84.5	49~ 84.5	11~ 83	31~ 84.5	49~ 84.5	15~ 83	32~ 84.5	49~ 84.5	27~ 83	34~ 84.5	49~ 84.5	42~ 83	49~ 84.5	53~ 84.5	
標準フック	35t												12.2t			
フック重量	950kg												440kg			
標準巻掛本数	2												1			

カウンタウエイト 98t、アウトリガ張出幅 8.0m
 ブーム+2.0m+35.5m油圧チルトジブ

単位:t

ブーム長さ(m) 作業半径 (m)	40.4			45.4			50.5			55.6			60.0			
	オフセット			オフセット			オフセット			オフセット			オフセット			
	0°	20°	40°	0°	20°	40°	0°	20°	40°	0°	20°	40°	0°	20°	40°	
14.0	17.2															
16.0	16.2			15.1												
18.0	15.3			14.3			12.9									
20.0	14.5			13.6			12.0			10.6						
22.0	13.7			12.9			11.1			9.8				9.4		
24.0	12.8			12.3			10.4			9.2				8.7		
26.0	12.0	7.9		11.7			9.8			8.6				8.2		
28.0	11.3	7.5		11.1	7.7		9.2			8.0				7.7		
30.0	10.7	7.1		10.6	7.3		8.7	6.8		7.5				7.2		
32.0	10.1	6.7		10.1	6.9		8.2	6.5		7.1	5.8			6.8	5.4	
34.0	9.6	6.4		9.7	6.6		7.8	6.2		6.7	5.6			6.4	5.0	
36.0	8.9	6.1	4.5	9.2	6.3		7.4	5.9		6.4	5.3			6.1	4.7	
38.0	8.4	5.8	4.3	8.8	6.0	4.4	7.0	5.7		6.0	5.0			5.8	4.4	
40.0	7.9	5.5	4.2	8.4	5.7	4.2	6.7	5.5	4.5	5.7	4.8			5.3	4.1	
42.0	7.4	5.3	4.0	8.0	5.5	4.1	6.3	5.2	4.4	5.5	4.6	4.1		4.9	3.9	3.3
44.0	7.0	5.0	3.9	7.5	5.3	4.0	6.0	5.0	4.3	5.2	4.4	3.9		4.5	3.6	3.1
46.0	6.6	4.8	3.8	7.1	5.0	3.9	5.7	4.8	4.1	4.8	4.2	3.7		4.1	3.4	2.9
48.0	6.2	4.6	3.7	6.7	4.8	3.7	5.4	4.7	4.0	4.5	4.0	3.5		3.7	3.2	2.7
50.0	5.9	4.4	3.6	6.4	4.7	3.7	5.1	4.5	3.9	4.1	3.8	3.3		3.4	3.0	2.6
54.0	5.3	4.1	3.4	5.8	4.3	3.5	4.5	4.1	3.7	3.6	3.4	3.0		2.8	2.6	2.3
58.0	4.8	3.8	3.3	5.2	4.0	3.3	3.9	3.6	3.4	3.0	2.9	2.7		2.3	2.3	2.0
62.0	4.3	3.6	3.2	4.7	3.8	3.2	3.5	3.2	3.0	2.6	2.5	2.4		1.9	1.9	1.8
66.0	4.0	3.4	3.2	4.0	3.6	3.2	3.1	2.8	2.7	2.2	2.1	2.1		1.5	1.6	1.6
70.0	3.4	3.3		3.2	3.4	3.2	2.7	2.5	2.4	1.9	1.8	1.8				
74.0	2.6			2.4	3.0		2.4	2.2	2.1	1.5	1.5	1.5				
78.0				1.7	2.0		1.8	2.0								
82.0								1.5								
θ(°)	14~ 83	34~ 84.5	46~ 84.5	18~ 83	26~ 84.5	47~ 84.5	28~ 83	29~ 84.5	47~ 84.5	39~ 83	48~ 84.5	53~ 84.5	50~ 83	58~ 84.5	63~ 84.5	
標準フック	35t												12.2t			
フック重量	950kg												440kg			
標準巻掛本数	2												1			

油圧チルトジブ

カウンタウエイト 98t、アウトリガ張出幅 8.0m

ブーム+2.0m+41.5m油圧チルトジブ

単位:t

ブーム長さ(m) 作業半径 (m)	40.4			45.4			50.5			55.6			60.0		
	オフセット			オフセット			オフセット			オフセット			オフセット		
	0°	20°	40°	0°	20°	40°	0°	20°	40°	0°	20°	40°	0°	20°	40°
16.0	13.4			12.3											
18.0	12.7			11.7			10.5								
20.0	12.0			11.1			10.0					8.9			
22.0	11.3			10.5			9.6				8.6				
24.0	10.6			10.0			9.2				8.2			7.7	
26.0	10.0			9.5			8.8				7.7			7.3	
28.0	9.3			9.1			8.2				7.2			6.8	
30.0	8.8	5.8		8.7			7.7				6.7			6.4	
32.0	8.3	5.4		8.3	5.6		7.3				6.3			6.0	
34.0	7.8	5.1		7.9	5.3		6.9	5.4			5.9			5.6	
36.0	7.4	4.8		7.5	5.0		6.5	5.1			5.6	4.6		5.1	3.7
38.0	7.0	4.5		7.1	4.7		6.1	4.9			5.3	4.3		4.7	3.4
40.0	6.5	4.2		6.7	4.4		5.8	4.6			5.0	4.0		4.3	3.1
42.0	6.1	4.0	2.8	6.4	4.2		5.5	4.4			4.6	3.7		3.9	2.9
44.0	5.7	3.8	2.6	6.1	4.0	2.7	5.1	4.1			4.2	3.4		3.6	2.7
46.0	5.3	3.6	2.5	5.8	3.8	2.6	4.8	3.9	2.6		3.8	3.2		3.3	2.5
48.0	4.9	3.4	2.4	5.4	3.6	2.5	4.4	3.7	2.5	3.5	3.0	2.5	2.5	2.9	2.3
50.0	4.6	3.2	2.3	5.1	3.4	2.4	4.1	3.5	2.4	3.2	2.7	2.3	2.3	2.6	2.1
54.0	4.1	2.9	2.1	4.5	3.1	2.2	3.5	3.1	2.3	2.6	2.4	2.0	2.0	2.1	1.7
58.0	3.6	2.6	2.0	4.0	2.8	2.0	3.0	2.7	2.1	2.1	2.0	1.7	1.6		
62.0	3.2	2.3	1.8	3.5	2.5	1.9	2.5	2.3	2.0	1.7	1.6				
66.0	2.8	2.1	1.7	3.1	2.3	1.8	2.1	1.9	1.8						
70.0	2.5	1.9	1.7	2.8	2.1	1.7	1.8	1.6	1.5						
74.0	2.2	1.8		2.3	1.9	1.7									
78.0	1.8	1.7		1.5	1.8										
θ(°)	20~ 83	30~ 84.5	51~ 84.5	29~ 83	39~ 84.5	51~ 84.5	44~ 83	54~ 84.5	60~ 84.5	54~ 83	63~ 84.5	73~ 84.5	59~ 83	70~ 84.5	80~ 84.5
標準フック	35t						12.2t								
フック重量	950kg						440kg								
標準巻掛本数	2						1								

カウンタウエイト 98t、アウトリガ張出幅 8.0m

ブーム+2.0m+47.5m油圧チルトジブ

単位:t

ブーム長さ(m) 作業半径 (m)	40.4		45.4		50.5		55.6		60.0	
	オフセット		オフセット		オフセット		オフセット		オフセット	
	0°	20°	0°	20°	0°	20°	0°	20°	0°	20°
16.0	10.7									
18.0	10.1		9.3							
20.0	9.6		8.8		7.8					
22.0	9.0		8.3		7.5		6.5			
24.0	8.5		7.9		7.1		6.3			
26.0	8.1		7.5		6.8		6.0		5.6	
28.0	7.6		7.1		6.5		5.8		5.4	
30.0	7.2		6.8		6.2		5.6		5.2	
32.0	6.7		6.5		5.9		5.3		4.9	
34.0	6.3	3.7	6.2		5.6		5.1		4.7	
36.0	5.9	3.5	5.9	3.6	5.4		4.9		4.2	
38.0	5.4	3.2	5.6	3.4	5.2	3.5	4.6		3.8	
40.0	5.0	3.0	5.3	3.1	4.9	3.3	4.2	3.1	3.5	
42.0	4.6	2.8	5.0	2.9	4.7	3.1	3.8	2.8	3.1	2.1
44.0	4.3	2.6	4.7	2.7	4.4	2.9	3.5	2.6	2.8	1.9
46.0	4.0	2.4	4.3	2.6	4.0	2.7	3.2	2.4	2.5	1.7
48.0	3.7	2.3	4.0	2.4	3.6	2.5	2.8	2.1	2.2	1.5
50.0	3.4	2.1	3.7	2.2	3.3	2.4	2.5	1.9	2.0	
54.0	2.9	1.8	3.2	1.9	2.7	2.1	2.0	1.5	1.5	
58.0	2.5	1.6	2.8	1.7	2.2	1.8	1.5			
62.0	2.1		2.4	1.5	1.8	1.6				
66.0	1.8		2.1							
70.0	1.5		1.8							
74.0			1.5							
θ(°)	40~ 84.5	62~ 84.5	40~ 84.5	62~ 84.5	54~ 84.5	65~ 84.5	60~ 84.5	72~ 84.5	64~ 84.5	77~ 84.5
標準フック	12.2t									
フック重量	440kg									
標準巻掛本数	1									

カウンタウエイト 78t、アウトリガ張出幅 8.5m

ブーム+2.0m+3.5m油圧チルトジブ

単位:t

ブーム長さ(m) 作業半径 (m)	40.4			45.4			50.5			55.6			60.0		
	オフセット			オフセット			オフセット			オフセット			オフセット		
	0°	20°	40°	0°	20°	40°	0°	20°	40°	0°	20°	40°	0°	20°	40°
8.0	47.7														
9.0	44.9	42.5		38.0											
10.0	42.5	40.3	38.9	36.1	33.9			28.4							
11.0	40.3	38.4	37.1	34.4	32.4	31.1	27.0	25.5		23.9					
12.0	38.3	36.6	35.5	32.9	31.1	29.9	25.7	24.4	23.5	22.8	21.5				
14.0	35.0	33.6	32.7	30.3	28.8	27.8	23.6	22.5	21.7	20.8	19.9	19.2	19.7		
16.0	32.2	31.0	30.3	28.1	26.8	26.0	21.8	20.9	20.3	19.2	18.5	18.0	18.2	17.5	17.1
18.0	29.9	28.9	28.3	26.0	25.1	24.4	20.3	19.5	19.0	17.8	17.2	16.8	16.9	16.3	15.9
20.0	27.9	27.0	26.5	24.2	23.6	23.1	19.0	18.3	17.9	16.6	16.1	15.8	15.7	15.2	14.9
22.0	26.1	25.4	25.0	22.6	22.1	21.8	17.9	17.3	16.9	15.6	15.1	14.8	14.7	14.3	14.1
24.0	24.6	24.0	23.7	21.3	20.8	20.6	16.9	16.3	16.0	14.7	14.3	14.0	13.9	13.5	13.3
26.0	23.3	22.8	22.5	20.0	19.7	19.5	16.0	15.5	15.2	13.9	13.5	13.3	13.1	12.8	12.6
28.0	21.0	21.3	21.5	19.0	18.6	18.5	15.2	14.8	14.6	13.1	12.8	12.6	12.4	12.1	12.0
30.0	18.6	18.9	19.0	18.0	17.7	17.6	14.5	14.1	13.9	12.5	12.2	12.1	11.8	11.5	11.4
32.0	16.5	16.8	16.8	16.8	16.9	16.8	13.9	13.6	13.4	11.9	11.7	11.5	11.2	11.0	10.9
34.0	14.8	14.9	15.0	15.0	15.2	15.3	13.3	13.0	12.9	11.4	11.2	11.0	10.7	10.5	10.4
36.0	13.2	13.3		13.5	13.6	13.7	12.8	12.6	12.4	10.9	10.7	10.6	10.3	10.1	10.0
38.0	11.7	11.9		12.1	12.2	12.3	12.4	12.1	12.0	10.5	10.3	10.2	9.8	9.7	9.6
40.0	10.4	10.4		10.7	10.8		11.4	11.5	11.6	10.1	9.9	9.9	9.5	9.3	9.2
42.0	9.1			9.4	9.6		10.1	10.3	10.3	9.7	9.6	9.5	9.1	9.0	8.9
44.0	5.6			8.3	8.4		9.0	9.1		9.4	9.3	9.2	8.8	8.7	8.6
46.0				7.4	7.4		8.0	8.1		8.6	8.7	8.7	8.5	8.4	8.3
48.0				6.5			7.1	7.1		7.6	7.8		7.7	7.8	7.8
50.0							6.2	6.3		6.8	6.9		6.8	6.9	
54.0							4.1			5.3	5.4		5.3	5.4	
58.0										4.1			4.0	4.1	
62.0													3.0		
θ(°)	0~ 84.5	27~ 84.5	43~ 84.5	13~ 84.5	23~ 84.5	42~ 84.5	0~ 84.5	25~ 84.5	42~ 84.5	13~ 84.5	27~ 84.5	42~ 84.5	15~ 84.5	27~ 84.5	45~ 84.5
標準フック	80t						35t								
フック重量	1550kg						950kg								
標準巻掛本数	5						3								

カウンタウエイト 78t、アウトリガ張出幅 8.5m

ブーム+2.0m+11.5m油圧チルトジブ

単位:t

ブーム長さ(m) 作業半径 (m)	40.4			45.4			50.5			55.6			60.0		
	オフセット			オフセット			オフセット			オフセット			オフセット		
	0°	20°	40°	0°	20°	40°	0°	20°	40°	0°	20°	40°	0°	20°	40°
10.0	38.8														
11.0	36.7			31.1											
12.0	34.8			29.6			23.3								
14.0	31.5	27.6		27.0	23.4		21.2			18.8					
16.0	28.9	26.1	22.7	24.8	21.8		19.4	16.7		17.4	14.9		15.6		
18.0	26.6	24.2	21.8	23.0	20.4	18.8	18.0	15.8	14.0	16.0	14.0		15.1		
20.0	24.7	22.6	21.0	21.5	19.2	17.8	16.7	15.0	13.4	14.9	13.2	12.0	14.0	12.5	
22.0	23.0	21.3	20.1	20.1	18.1	16.9	15.6	14.1	12.8	13.9	12.5	11.4	13.1	11.9	
24.0	21.6	20.0	19.0	18.9	17.2	16.1	14.7	13.3	12.3	13.0	11.9	10.9	12.3	11.3	10.4
26.0	20.3	18.9	18.1	17.9	16.3	15.3	13.8	12.6	11.9	12.2	11.3	10.5	11.5	10.7	9.9
28.0	19.2	18.0	17.2	17.0	15.5	14.7	13.1	12.0	11.4	11.5	10.8	10.0	10.9	10.2	9.5
30.0	18.2	17.1	16.4	16.1	14.9	14.1	12.4	11.4	10.9	10.9	10.2	9.7	10.3	9.7	9.2
32.0	17.3	16.3	15.7	15.2	14.2	13.5	11.8	10.9	10.4	10.3	9.7	9.3	9.7	9.2	8.8
34.0	15.5	15.6	15.1	14.5	13.7	13.1	11.2	10.4	10.0	9.8	9.3	8.9	9.3	8.7	8.4
36.0	13.9	14.6	14.5	13.8	13.2	12.6	10.7	10.0	9.6	9.4	8.9	8.5	8.8	8.4	8.1
38.0	12.5	13.2	13.6	12.7	12.7	12.2	10.3	9.6	9.3	9.0	8.5	8.2	8.4	8.0	7.7
40.0	11.2	11.8	12.2	11.4	12.1	11.8	9.9	9.3	8.9	8.6	8.1	7.9	8.0	7.7	7.4
42.0	10.0	10.6	10.9	10.2	10.9	11.2	9.5	8.9	8.6	8.2	7.8	7.6	7.7	7.3	7.1
44.0	8.9	9.4		9.1	9.7	10.1	9.1	8.6	8.4	7.9	7.5	7.3	7.4	7.1	6.9
46.0	7.9	8.3		8.1	8.6	8.9	8.4	8.4	8.1	7.6	7.3	7.1	7.1	6.8	6.6
48.0	7.0	7.3		7.1	7.6		7.5	8.0	7.9	7.3	7.0	6.8	6.8	6.6	6.4
50.0	6.2			6.3	6.7		6.6	7.1	7.4	7.1	6.8	6.6	6.5	6.3	6.2
54.0				4.9	5.1		5.2	5.5		5.6	6.0	6.2	5.4	5.6	5.6
58.0							4.0	4.2		4.3	4.6		4.1	4.5	
62.0							2.0			3.2	3.4		3.0	3.3	
66.0										2.3			2.1	2.3	
θ(°)	17~ 83	28~ 84.5	44~ 84.5	20~ 83	24~ 84.5	44~ 84.5	0~ 83	26~ 84.5	43~ 84.5	12~ 83	28~ 84.5	43~ 84.5	25~ 83	28~ 84.5	48~ 84.5
標準フック	80t						35t								
フック重量	1550kg						950kg								
標準巻掛本数	4						3								

油圧チルトジブ

カウンタウエイト 78t、アウトリガ張出幅 8.5m

ブーム+2.0m+17.5m油圧チルトジブ

単位:t

ブーム長さ(m) 作業半径 (m)	40.4			45.4			50.5			55.6			60.0		
	オフセット			オフセット			オフセット			オフセット			オフセット		
	0°	20°	40°	0°	20°	40°	0°	20°	40°	0°	20°	40°	0°	20°	40°
11.0	31.5														
12.0	30.3			27.0											
14.0	28.1			24.6					19.5						
16.0	26.3	20.6		22.6					17.9			15.6			14.8
18.0	24.6	19.5		20.8	17.9				16.5	13.4		14.5			13.7
20.0	22.8	18.6		19.4	16.8				15.3	12.7		13.5	11.3		12.8
22.0	21.2	17.8	14.0	18.1	15.8				14.3	12.0		12.6	10.7		12.0
24.0	19.9	17.1	13.6	17.0	15.0	13.7			13.4	11.5	10.1	11.9	10.1		11.2
26.0	18.6	16.4	13.3	16.0	14.2	13.1	12.5	11.0	9.7	11.1	9.6	8.7	10.5	9.2	8.3
28.0	17.6	15.8	12.9	15.1	13.5	12.5	11.8	10.5	9.3	10.5	9.2	8.3	9.9	8.7	7.9
30.0	16.6	15.3	12.7	14.4	12.9	12.0	11.2	10.1	9.0	9.9	8.8	8.0	9.3	8.4	7.6
32.0	15.7	14.6	12.4	13.6	12.3	11.5	10.6	9.6	8.7	9.3	8.4	7.7	8.8	8.0	7.3
34.0	15.0	13.9	12.2	13.0	11.8	11.1	10.1	9.2	8.5	8.8	8.1	7.4	8.3	7.7	7.1
36.0	14.3	13.3	12.0	12.4	11.3	10.6	9.6	8.8	8.2	8.4	7.7	7.1	7.9	7.4	6.8
38.0	13.0	12.8	11.8	11.9	10.9	10.3	9.2	8.4	8.0	8.0	7.4	6.9	7.5	7.0	6.6
40.0	11.7	12.3	11.7	11.4	10.5	9.9	8.8	8.1	7.7	7.6	7.1	6.7	7.2	6.7	6.4
42.0	10.5	11.5	11.4	10.5	10.1	9.6	8.4	7.8	7.4	7.3	6.8	6.5	6.9	6.4	6.2
44.0	9.4	10.4	10.9	9.4	9.8	9.3	8.0	7.5	7.1	7.0	6.5	6.3	6.5	6.2	6.0
46.0	8.4	9.2	9.8	8.4	9.3	9.1	7.7	7.2	6.9	6.7	6.3	6.1	6.3	5.9	5.7
48.0	7.5	8.2	8.6	7.4	8.3	8.8	7.5	7.0	6.7	6.4	6.0	5.9	5.9	5.6	5.5
50.0	6.6	7.3		6.6	7.4	7.8	7.0	6.7	6.5	6.2	5.8	5.6	5.5	5.3	5.3
54.0	5.2	5.6		5.1	5.7		5.5	6.1	6.1	5.7	5.4	5.3	4.8	4.7	4.7
58.0				3.9	4.3		4.2	4.7		4.4	5.0	5.0	4.2	4.1	4.2
62.0				2.9			3.1	3.5		3.3	3.8		3.1	3.6	3.7
66.0							2.2			2.4	2.7		2.1	2.6	
70.0										1.6	1.7			1.6	
θ(°)	23~ 83	28~ 84.5	44~ 84.5	11~ 83	30~ 84.5	48~ 84.5	16~ 83	31~ 84.5	47~ 84.5	19~ 83	23~ 84.5	47~ 84.5	34~ 83	33~ 84.5	46~ 84.5
標準フック	35t						35t								
フック重量	950kg						950kg								
標準巻掛本数	3						2								

カウンタウエイト 78t、アウトリガ張出幅 8.5m

ブーム+2.0m+23.5m油圧チルトジブ

単位:t

ブーム長さ(m) 作業半径 (m)	40.4			45.4			50.5			55.6			60.0		
	オフセット			オフセット			オフセット			オフセット			オフセット		
	0°	20°	40°	0°	20°	40°	0°	20°	40°	0°	20°	40°	0°	20°	40°
12.0	25.7														
14.0	23.9			22.1					17.6						
16.0	22.2			20.7					16.2			14.2			
18.0	20.8			19.3					15.0			13.1			12.4
20.0	19.6	14.4		17.9					14.0			12.2			11.6
22.0	18.5	13.6		16.7	13.8				13.1	10.3		11.4			10.8
24.0	17.5	12.9		15.6	13.2				12.2	9.8		10.6	8.8		10.1
26.0	16.6	12.3	9.3	14.7	12.6				11.4	9.4		10.0	8.3		9.5
28.0	15.8	11.7	9.0	13.8	12.1	9.1	10.7	9.0		9.4	7.9		9.0	7.6	
30.0	15.1	11.2	8.7	13.1	11.5	8.9	10.1	8.6	7.5	8.9	7.6	6.7	8.5	7.2	
32.0	14.5	10.7	8.5	12.4	11.0	8.6	9.6	8.2	7.2	8.5	7.2	6.5	8.0	6.9	6.2
34.0	13.9	10.3	8.3	11.8	10.5	8.4	9.1	7.9	7.0	8.0	6.9	6.2	7.6	6.6	6.0
36.0	13.2	9.9	8.1	11.2	10.0	8.2	8.6	7.6	6.8	7.6	6.6	6.0	7.2	6.3	5.7
38.0	12.6	9.6	7.9	10.7	9.6	8.1	8.2	7.3	6.5	7.2	6.4	5.8	6.8	6.1	5.5
40.0	12.0	9.2	7.7	10.2	9.2	7.9	7.8	7.1	6.3	6.9	6.1	5.6	6.5	5.8	5.3
42.0	11.0	8.9	7.6	9.8	8.9	7.7	7.5	6.8	6.2	6.5	5.9	5.4	6.1	5.6	5.1
44.0	9.8	8.6	7.5	9.4	8.6	7.6	7.1	6.5	6.0	6.2	5.7	5.2	5.8	5.4	4.9
46.0	8.8	8.4	7.4	8.7	8.3	7.5	6.8	6.3	5.8	5.9	5.5	5.0	5.4	5.1	4.7
48.0	7.9	8.1	7.3	7.8	8.0	7.4	6.6	6.0	5.7	5.7	5.3	4.9	5.0	4.8	4.5
50.0	7.0	7.9	7.2	6.9	7.7	7.3	6.3	5.8	5.5	5.4	5.1	4.7	4.6	4.4	4.3
54.0	5.5	6.3	6.7	5.4	6.4	6.9	5.6	5.4	5.2	4.8	4.6	4.4	4.0	3.9	3.9
58.0	4.3	4.8		4.1	4.9	5.3	4.3	5.1	4.9	4.3	4.1	4.0	3.4	3.4	3.4
62.0	3.2			3.1	3.6		3.2	3.9	4.2	3.3	3.7	3.6	2.9	2.9	3.0
66.0				2.1	2.4		2.3	2.8		2.4	3.0	3.3	2.1	2.5	2.6
70.0								1.8		1.5	2.0			1.9	
θ(°)	16~ 83	33~ 84.5	45~ 84.5	19~ 83	25~ 84.5	45~ 84.5	29~ 83	27~ 84.5	45~ 84.5	30~ 83	36~ 84.5	45~ 84.5	41~ 83	42~ 84.5	50~ 84.5
標準フック	35t						35t								
フック重量	950kg						950kg								
標準巻掛本数	3						2								

カウンタウエイト 78t、アウトリガ張出幅 8.5m

ブーム+2.0m+29.5m油圧チルトジブ

単位:t

ブーム長さ(m) 作業半径 (m)	40.4			45.4			50.5			55.6			60.0		
	オフセット			オフセット			オフセット			オフセット			オフセット		
	0°	20°	40°	0°	20°	40°	0°	20°	40°	0°	20°	40°	0°	20°	40°
14.0	20.4			18.9											
16.0	19.0			17.7			14.7								
18.0	17.8			16.7			13.6			12.4					
20.0	16.7			15.7			12.6			11.4			10.9		
22.0	15.8			14.9			11.7			10.6			10.1		
24.0	14.9	10.2		14.1	10.5		11.0			9.9			9.5		
26.0	14.1	9.6		13.4	9.9		10.3	8.2		9.3			8.9		
28.0	13.4	9.1		12.7	9.4		9.8	7.8		8.7	7.2		8.3		
30.0	12.8	8.7		11.9	9.0		9.2	7.4		8.2	6.8		7.9	6.5	
32.0	12.2	8.3	6.2	11.3	8.6	6.3	8.7	7.1		7.8	6.5		7.4	6.2	
34.0	11.4	7.9	6.0	10.7	8.2	6.1	8.2	6.8	5.9	7.4	6.2		7.0	5.9	
36.0	10.7	7.6	5.9	10.2	7.9	6.0	7.8	6.5	5.7	7.0	5.9	5.3	6.7	5.5	
38.0	10.0	7.2	5.7	9.7	7.5	5.8	7.4	6.3	5.5	6.7	5.7	5.1	6.3	5.2	4.4
40.0	9.5	6.9	5.5	9.2	7.2	5.6	7.0	6.0	5.3	6.4	5.4	4.9	5.9	4.9	4.2
42.0	8.9	6.7	5.4	8.8	7.0	5.5	6.7	5.8	5.1	6.0	5.2	4.7	5.4	4.6	4.0
44.0	8.5	6.4	5.3	8.4	6.7	5.4	6.4	5.6	5.0	5.7	5.0	4.5	5.0	4.3	3.8
46.0	8.0	6.2	5.1	8.1	6.5	5.2	6.1	5.4	4.8	5.4	4.8	4.3	4.6	4.1	3.6
48.0	7.6	6.0	5.0	7.7	6.3	5.1	5.8	5.2	4.7	5.1	4.6	4.2	4.2	3.9	3.4
50.0	7.2	5.8	5.0	7.0	6.1	5.0	5.5	5.1	4.6	4.7	4.4	4.1	3.9	3.6	3.3
54.0	5.7	5.4	4.8	5.5	5.7	4.9	4.9	4.5	4.3	4.1	3.9	3.8	3.3	3.2	3.0
58.0	4.4	5.1	4.8	4.2	5.3	4.8	4.3	4.1	3.9	3.6	3.4	3.3	2.8	2.7	2.7
62.0	3.3	4.0		3.1	4.0	4.5	3.2	3.7	3.5	3.2	3.0	2.9	2.3	2.3	2.4
66.0	2.4	2.8		2.2	2.8		2.2	3.0	3.2	2.5	2.6	2.6	1.9	1.9	2.0
70.0					1.8			2.0		1.6	2.3	2.3		1.6	1.7
74.0											1.5				
θ(°)	21~ 83	29~ 84.5	49~ 84.5	31~ 83	31~ 84.5	49~ 84.5	37~ 83	39~ 84.5	49~ 84.5	38~ 83	40~ 84.5	49~ 84.5	46~ 83	49~ 84.5	53~ 84.5
標準フック	35t												12.2t		
フック重量	950kg												440kg		
標準巻掛本数	2												1		

カウンタウエイト 78t、アウトリガ張出幅 8.5m

ブーム+2.0m+35.5m油圧チルトジブ

単位:t

ブーム長さ(m) 作業半径 (m)	40.4			45.4			50.5			55.6			60.0		
	オフセット			オフセット			オフセット			オフセット			オフセット		
	0°	20°	40°	0°	20°	40°	0°	20°	40°	0°	20°	40°	0°	20°	40°
14.0	17.2														
16.0	16.2			15.1											
18.0	15.3			14.3			12.9								
20.0	14.5			13.6			12.0			10.6					
22.0	13.7			12.9			11.1			9.8			9.4		
24.0	12.8			12.3			10.4			9.2			8.7		
26.0	12.0	7.9		11.7			9.8			8.6			8.2		
28.0	11.3	7.5		11.1	7.7		9.2			8.0			7.7		
30.0	10.7	7.1		10.6	7.3		8.7	6.8		7.5			7.2		
32.0	10.1	6.7		10.1	6.9		8.2	6.5		7.1	5.8		6.8	5.4	
34.0	9.6	6.4		9.7	6.6		7.8	6.2		6.7	5.6		6.4	5.0	
36.0	8.9	6.1	4.5	9.2	6.3		7.4	5.9		6.4	5.3		6.1	4.7	
38.0	8.4	5.8	4.3	8.8	6.0	4.4	7.0	5.7		6.0	5.0		5.8	4.4	
40.0	7.9	5.5	4.2	8.4	5.7	4.2	6.7	5.5	4.5	5.7	4.8		5.3	4.1	
42.0	7.4	5.3	4.0	8.0	5.5	4.1	6.3	5.2	4.4	5.5	4.6	4.1	4.9	3.9	3.3
44.0	7.0	5.0	3.9	7.5	5.3	4.0	6.0	5.0	4.3	5.2	4.4	3.9	4.5	3.6	3.1
46.0	6.6	4.8	3.8	7.1	5.0	3.9	5.7	4.8	4.1	4.8	4.2	3.7	4.1	3.4	2.9
48.0	6.2	4.6	3.7	6.7	4.8	3.7	5.4	4.7	4.0	4.5	4.0	3.5	3.7	3.2	2.7
50.0	5.9	4.4	3.6	6.4	4.7	3.7	5.1	4.5	3.9	4.1	3.8	3.3	3.4	3.0	2.6
54.0	5.3	4.1	3.4	5.7	4.3	3.5	4.5	4.1	3.7	3.6	3.4	3.0	2.8	2.6	2.3
58.0	4.7	3.8	3.3	4.4	4.0	3.3	3.9	3.6	3.4	3.0	2.9	2.7	2.3	2.3	2.0
62.0	3.5	3.6	3.2	3.3	3.8	3.2	3.5	3.2	3.0	2.6	2.5	2.4	1.9	1.9	1.8
66.0	2.6	3.4	3.2	2.4	3.4	3.2	2.8	2.7	2.2	2.1	2.1	2.1	1.5	1.6	1.6
70.0	1.8	2.4		1.5	2.3	2.8	1.7	2.5	2.4	1.7	1.8	1.8			
74.0								1.7	2.1		1.5	1.5			
θ(°)	25~ 83	34~ 84.5	46~ 84.5	33~ 83	42~ 84.5	47~ 84.5	39~ 83	42~ 84.5	47~ 84.5	43~ 83	48~ 84.5	53~ 84.5	50~ 83	58~ 84.5	63~ 84.5
標準フック	35t												12.2t		
フック重量	950kg												440kg		
標準巻掛本数	2												1		

油圧チルトジブ

カウンタウエイト 78t、アウトリガ張出幅 8.5m

ブーム+2.0m+41.5m油圧チルトジブ

単位:t

ブーム長さ(m) 作業半径 (m)	40.4			45.4			50.5			55.6			60.0		
	オフセット			オフセット			オフセット			オフセット			オフセット		
	0°	20°	40°	0°	20°	40°	0°	20°	40°	0°	20°	40°	0°	20°	40°
16.0	13.4			12.3											
18.0	12.7			11.7			10.5								
20.0	12.0			11.1			10.0					8.9			
22.0	11.3			10.5			9.6				8.6				
24.0	10.6			10.0			9.2				8.2			7.7	
26.0	10.0			9.5			8.8				7.7			7.3	
28.0	9.3			9.1			8.2				7.2			6.8	
30.0	8.8	5.8		8.7			7.7				6.7			6.4	
32.0	8.3	5.4		8.3	5.6		7.3				6.3			6.0	
34.0	7.8	5.1		7.9	5.3		6.9	5.4			5.9			5.6	
36.0	7.4	4.8		7.5	5.0		6.5	5.1			5.6	4.6		5.1	3.7
38.0	7.0	4.5		7.1	4.7		6.1	4.9			5.3	4.3		4.7	3.4
40.0	6.5	4.2		6.7	4.4		5.8	4.6			5.0	4.0		4.3	3.1
42.0	6.1	4.0	2.8	6.4	4.2		5.5	4.4			4.6	3.7		3.9	2.9
44.0	5.7	3.8	2.6	6.1	4.0	2.7	5.1	4.1			4.2	3.4		3.6	2.7
46.0	5.3	3.6	2.5	5.8	3.8	2.6	4.8	3.9	2.6		3.8	3.2		3.3	2.5
48.0	4.9	3.4	2.4	5.4	3.6	2.5	4.4	3.7	2.5	3.5	3.0	2.5	2.9	2.3	1.9
50.0	4.6	3.2	2.3	5.1	3.4	2.4	4.1	3.5	2.4	3.2	2.7	2.3	2.6	2.1	1.7
54.0	4.1	2.9	2.1	4.5	3.1	2.2	3.5	3.1	2.3	2.6	2.4	2.0	2.1	1.7	
58.0	3.6	2.6	2.0	4.0	2.8	2.0	3.0	2.7	2.1	2.1	2.0	1.7	1.6		
62.0	3.2	2.3	1.8	3.3	2.5	1.9	2.5	2.3	2.0	1.7	1.6				
66.0	2.5	2.1	1.7	2.3	2.3	1.8	2.1	1.9	1.8						
70.0	1.7	1.9	1.7	1.5	2.1	1.7		1.6	1.5						
74.0		1.6			1.6	1.7									
θ(°)	34~ 83	38~ 84.5	51~ 84.5	39~ 83	44~ 84.5	51~ 84.5	47~ 83	54~ 84.5	60~ 84.5	54~ 83	63~ 84.5	73~ 84.5	59~ 83	70~ 84.5	80~ 84.5
標準フック	35t						12.2t								
フック重量	950kg						440kg								
標準巻掛本数	2						1								

カウンタウエイト 78t、アウトリガ張出幅 8.5m

ブーム+2.0m+47.5m油圧チルトジブ

単位:t

ブーム長さ(m) 作業半径 (m)	40.4		45.4		50.5		55.6		60.0	
	オフセット		オフセット		オフセット		オフセット		オフセット	
	0°	20°	0°	20°	0°	20°	0°	20°	0°	20°
16.0	10.7									
18.0	10.1		9.3							
20.0	9.6		8.8		7.8					
22.0	9.0		8.3		7.5		6.5			
24.0	8.5		7.9		7.1		6.3			
26.0	8.1		7.5		6.8		6.0		5.6	
28.0	7.6		7.1		6.5		5.8		5.4	
30.0	7.2		6.8		6.2		5.6		5.2	
32.0	6.7		6.5		5.9		5.3		4.9	
34.0	6.3	3.7	6.2		5.6		5.1		4.7	
36.0	5.9	3.5	5.9	3.6	5.4		4.9		4.2	
38.0	5.4	3.2	5.6	3.4	5.2	3.5	4.6		3.8	
40.0	5.0	3.0	5.3	3.1	4.9	3.3	4.2	3.1	3.5	
42.0	4.6	2.8	5.0	2.9	4.7	3.1	3.8	2.8	3.1	2.1
44.0	4.3	2.6	4.7	2.7	4.4	2.9	3.5	2.6	2.8	1.9
46.0	4.0	2.4	4.3	2.6	4.0	2.7	3.2	2.4	2.5	1.7
48.0	3.7	2.3	4.0	2.4	3.6	2.5	2.8	2.1	2.2	1.5
50.0	3.4	2.1	3.7	2.2	3.3	2.4	2.5	1.9	2.0	
54.0	2.9	1.8	3.2	1.9	2.7	2.1	2.0	1.5	1.5	
58.0	2.5	1.6	2.8	1.7	2.2	1.8	1.5			
62.0	2.1		2.4	1.5	1.8	1.6				
66.0	1.8		2.1							
70.0	1.5									
θ(°)	40~ 84.5	62~ 84.5	48~ 84.5	62~ 84.5	54~ 84.5	65~ 84.5	60~ 84.5	72~ 84.5	64~ 84.5	77~ 84.5
標準フック	12.2t									
フック重量	440kg									
標準巻掛本数	1									

カウンタウエイト 78t、アウトリガ張出幅 8.0m

ブーム+2.0m+3.5m油圧チルトジブ

単位:t

ブーム長さ(m) 作業半径 (m)	40.4			45.4			50.5			55.6			60.0		
	オフセット			オフセット			オフセット			オフセット			オフセット		
	0°	20°	40°	0°	20°	40°	0°	20°	40°	0°	20°	40°	0°	20°	40°
8.0	47.7														
9.0	44.9	42.5		38.0											
10.0	42.5	40.3	38.9	36.1	33.9			28.4							
11.0	40.3	38.4	37.1	34.4	32.4	31.1	27.0	25.5		23.9					
12.0	38.3	36.6	35.5	32.9	31.1	29.9	25.7	24.4	23.5	22.8	21.5				
14.0	35.0	33.6	32.7	30.3	28.8	27.8	23.6	22.5	21.7	20.8	19.9	19.2	19.7		
16.0	32.2	31.0	30.3	28.1	26.8	26.0	21.8	20.9	20.3	19.2	18.5	18.0	18.2	17.5	17.1
18.0	29.9	28.9	28.3	26.0	25.1	24.4	20.3	19.5	19.0	17.8	17.2	16.8	16.9	16.3	15.9
20.0	27.9	27.0	26.5	24.2	23.6	23.1	19.0	18.3	17.9	16.6	16.1	15.8	15.7	15.2	14.9
22.0	26.1	25.4	25.0	22.6	22.1	21.8	17.9	17.3	16.9	15.6	15.1	14.8	14.7	14.3	14.1
24.0	24.6	24.0	23.7	21.3	20.8	20.6	16.9	16.3	16.0	14.7	14.3	14.0	13.9	13.5	13.3
26.0	22.5	22.8	22.5	20.0	19.7	19.5	16.0	15.5	15.2	13.9	13.5	13.3	13.1	12.8	12.6
28.0	19.8	20.1	20.2	19.0	18.6	18.5	15.2	14.8	14.6	13.1	12.8	12.6	12.4	12.1	12.0
30.0	17.4	17.7	17.8	17.7	17.6	17.6	14.5	14.1	13.9	12.5	12.2	12.1	11.8	11.5	11.4
32.0	15.4	15.6	15.7	15.7	15.9	16.1	13.9	13.6	13.4	11.9	11.7	11.5	11.2	11.0	10.9
34.0	13.7	13.9	13.9	14.0	14.2	14.3	13.3	13.0	12.9	11.4	11.2	11.0	10.7	10.5	10.4
36.0	12.2	12.3		12.5	12.6	12.7	12.8	12.6	12.4	10.9	10.7	10.6	10.3	10.1	10.0
38.0	10.7	10.8		11.0	11.2	11.2	11.7	11.8	11.9	10.5	10.3	10.2	9.8	9.7	9.6
40.0	9.3	9.4		9.7	9.8		10.4	10.6	10.6	10.1	9.9	9.9	9.5	9.3	9.2
42.0	8.2			8.5	8.6		9.2	9.3	9.4	9.7	9.6	9.5	9.1	9.0	8.9
44.0	5.6			7.4	7.5		8.1	8.2		8.7	8.9	8.9	8.7	8.7	8.6
46.0				6.5	6.5		7.1	7.2		7.7	7.9	7.9	7.8	7.9	8.0
48.0				5.7			6.3	6.3		6.8	6.9		6.9	7.0	7.0
50.0							5.5	5.5		6.0	6.1		6.0	6.2	
54.0							4.1			4.6	4.7		4.6	4.7	
58.0										3.5			3.4	3.4	
62.0													2.4		
θ(°)	0~ 84.5	27~ 84.5	43~ 84.5	13~ 84.5	23~ 84.5	42~ 84.5	0~ 84.5	25~ 84.5	42~ 84.5	13~ 84.5	27~ 84.5	42~ 84.5	15~ 84.5	27~ 84.5	45~ 84.5
標準フック	80t						35t								
フック重量	1550kg						950kg								
標準巻掛本数	5						3								

カウンタウエイト 78t、アウトリガ張出幅 8.0m

ブーム+2.0m+11.5m油圧チルトジブ

単位:t

ブーム長さ(m) 作業半径 (m)	40.4			45.4			50.5			55.6			60.0		
	オフセット			オフセット			オフセット			オフセット			オフセット		
	0°	20°	40°	0°	20°	40°	0°	20°	40°	0°	20°	40°	0°	20°	40°
10.0	38.8														
11.0	36.7			31.1											
12.0	34.8			29.6			23.3								
14.0	31.5	27.6		27.0	23.4		21.2			18.8					
16.0	28.9	26.1	22.7	24.8	21.8		19.4	16.7		17.4	14.9		15.6		
18.0	26.6	24.2	21.8	23.0	20.4	18.8	18.0	15.8	14.0	16.0	14.0		15.1		
20.0	24.7	22.6	21.0	21.5	19.2	17.8	16.7	15.0	13.4	14.9	13.2	12.0	14.0	12.5	
22.0	23.0	21.3	20.1	20.1	18.1	16.9	15.6	14.1	12.8	13.9	12.5	11.4	13.1	11.9	
24.0	21.6	20.0	19.0	18.9	17.2	16.1	14.7	13.3	12.3	13.0	11.9	10.9	12.3	11.3	10.4
26.0	20.3	18.9	18.1	17.9	16.3	15.3	13.8	12.6	11.9	12.2	11.3	10.5	11.5	10.7	9.9
28.0	19.2	18.0	17.2	17.0	15.5	14.7	13.1	12.0	11.4	11.5	10.8	10.0	10.9	10.2	9.5
30.0	18.2	17.1	16.4	16.1	14.9	14.1	12.4	11.4	10.9	10.9	10.2	9.7	10.3	9.7	9.2
32.0	16.2	16.3	15.7	15.2	14.2	13.5	11.8	10.9	10.4	10.3	9.7	9.3	9.7	9.2	8.8
34.0	14.4	15.2	15.1	14.5	13.7	13.1	11.2	10.4	10.0	9.8	9.3	8.9	9.3	8.7	8.4
36.0	12.9	13.6	14.1	13.1	13.2	12.6	10.7	10.0	9.6	9.4	8.9	8.5	8.8	8.4	8.1
38.0	11.6	12.2	12.6	11.7	12.4	12.2	10.3	9.6	9.3	9.0	8.5	8.2	8.4	8.0	7.7
40.0	10.2	10.9	11.3	10.4	11.2	11.6	9.9	9.3	8.9	8.6	8.1	7.9	8.0	7.7	7.4
42.0	9.0	9.7	10.0	9.2	10.0	10.4	9.5	8.9	8.6	8.2	7.8	7.6	7.7	7.3	7.1
44.0	8.0	8.5		8.2	8.8	9.1	8.5	8.6	8.4	7.9	7.5	7.3	7.4	7.1	6.9
46.0	7.0	7.5		7.2	7.7	8.0	7.6	8.2	8.1	7.6	7.3	7.1	7.1	6.8	6.6
48.0	6.2	6.5		6.3	6.8		6.7	7.2	7.5	7.1	7.0	6.8	6.8	6.6	6.4
50.0	5.4			5.5	5.9		5.9	6.4	6.6	6.3	6.8	6.6	6.1	6.3	6.2
54.0				4.1	4.4		4.5	4.8		4.9	5.3	5.5	4.7	5.2	5.4
58.0							3.3	3.5		3.7	4.0		3.5	3.9	
62.0							2.0			2.6	2.8		2.4	2.7	
66.0										1.8			1.6	1.8	
θ(°)	17~ 83	28~ 84.5	44~ 84.5	20~ 83	24~ 84.5	44~ 84.5	0~ 83	26~ 84.5	43~ 84.5	12~ 83	28~ 84.5	43~ 84.5	25~ 83	28~ 84.5	48~ 84.5
標準フック	80t						35t								
フック重量	1550kg						950kg								
標準巻掛本数	4						3								

油圧チルトジブ

カウンタウエイト 78t、アウトリガ張出幅 8.0m

ブーム+2.0m+17.5m油圧チルトジブ

単位:t

ブーム長さ(m) 作業半径 (m)	40.4			45.4			50.5			55.6			60.0		
	オフセット			オフセット			オフセット			オフセット			オフセット		
	0°	20°	40°	0°	20°	40°	0°	20°	40°	0°	20°	40°	0°	20°	40°
11.0	31.5														
12.0	30.3			27.0											
14.0	28.1			24.6			19.5								
16.0	26.3	20.6		22.6			17.9			15.6			14.8		
18.0	24.6	19.5		20.8	17.9		16.5	13.4		14.5			13.7		
20.0	22.8	18.6		19.4	16.8		15.3	12.7		13.5	11.3		12.8		
22.0	21.2	17.8	14.0	18.1	15.8		14.3	12.0		12.6	10.7		12.0	10.2	
24.0	19.9	17.1	13.6	17.0	15.0	13.7	13.4	11.5	10.1	11.9	10.1		11.2	9.6	
26.0	18.6	16.4	13.3	16.0	14.2	13.1	12.5	11.0	9.7	11.1	9.6	8.7	10.5	9.2	8.3
28.0	17.6	15.8	12.9	15.1	13.5	12.5	11.8	10.5	9.3	10.5	9.2	8.3	9.9	8.7	7.9
30.0	16.6	15.3	12.7	14.4	12.9	12.0	11.2	10.1	9.0	9.9	8.8	8.0	9.3	8.4	7.6
32.0	15.7	14.6	12.4	13.6	12.3	11.5	10.6	9.6	8.7	9.3	8.4	7.7	8.8	8.0	7.3
34.0	14.9	13.9	12.2	13.0	11.8	11.1	10.1	9.2	8.5	8.8	8.1	7.4	8.3	7.7	7.1
36.0	13.4	13.3	12.0	12.4	11.3	10.6	9.6	8.8	8.2	8.4	7.7	7.1	7.9	7.4	6.8
38.0	12.0	12.8	11.8	11.9	10.9	10.3	9.2	8.4	8.0	8.0	7.4	6.9	7.5	7.0	6.6
40.0	10.8	11.8	11.7	10.8	10.5	9.9	8.8	8.1	7.7	7.6	7.1	6.7	7.2	6.7	6.4
42.0	9.6	10.6	11.2	9.6	10.1	9.6	8.4	7.8	7.4	7.3	6.8	6.5	6.9	6.4	6.2
44.0	8.5	9.5	10.0	8.5	9.6	9.3	8.0	7.5	7.1	7.0	6.5	6.3	6.5	6.2	6.0
46.0	7.5	8.4	8.9	7.5	8.5	9.1	7.7	7.2	6.9	6.7	6.3	6.1	6.3	5.9	5.7
48.0	6.6	7.4	7.8	6.6	7.5	8.0	7.0	7.0	6.7	6.4	6.0	5.9	5.9	5.6	5.5
50.0	5.8	6.5		5.8	6.6	7.0	6.2	6.7	6.5	6.2	5.8	5.6	5.5	5.3	5.3
54.0	4.5	4.8		4.4	5.0		4.7	5.4	5.8	4.9	5.4	5.3	4.7	4.7	4.7
58.0				3.2	3.6		3.5	4.0		3.7	4.3	4.7	3.5	4.1	4.2
62.0				2.3			2.5	2.9		2.7	3.2		2.5	3.0	3.3
66.0							1.6			1.8	2.1		1.6	2.0	
θ(°)	23~83	28~84.5	44~84.5	11~83	30~84.5	48~84.5	16~83	31~84.5	47~84.5	28~83	32~84.5	47~84.5	34~83	39~84.5	46~84.5
標準フック フック重量	35t 950kg						35t 950kg								
標準巻掛本数	3						2								

カウンタウエイト 78t、アウトリガ張出幅 8.0m

ブーム+2.0m+23.5m油圧チルトジブ

単位:t

ブーム長さ(m) 作業半径 (m)	40.4			45.4			50.5			55.6			60.0		
	オフセット			オフセット			オフセット			オフセット			オフセット		
	0°	20°	40°	0°	20°	40°	0°	20°	40°	0°	20°	40°	0°	20°	40°
12.0	25.7														
14.0	23.9			22.1			17.6								
16.0	22.2			20.7			16.2			14.2					
18.0	20.8			19.3			15.0			13.1			12.4		
20.0	19.6	14.4		17.9			14.0			12.2			11.6		
22.0	18.5	13.6		16.7	13.8		13.1	10.3		11.4			10.8		
24.0	17.5	12.9		15.6	13.2		12.2	9.8		10.6	8.8		10.1		
26.0	16.6	12.3	9.3	14.7	12.6		11.4	9.4		10.0	8.3		9.5	8.0	
28.0	15.8	11.7	9.0	13.8	12.1	9.1	10.7	9.0		9.4	7.9		9.0	7.6	
30.0	15.1	11.2	8.7	13.1	11.5	8.9	10.1	8.6	7.5	8.9	7.6	6.7	8.5	7.2	
32.0	14.5	10.7	8.5	12.4	11.0	8.6	9.6	8.2	7.2	8.5	7.2	6.5	8.0	6.9	6.2
34.0	13.9	10.3	8.3	11.8	10.5	8.4	9.1	7.9	7.0	8.0	6.9	6.2	7.6	6.6	6.0
36.0	13.2	9.9	8.1	11.2	10.0	8.2	8.6	7.6	6.8	7.6	6.6	6.0	7.2	6.3	5.7
38.0	12.4	9.6	7.9	10.7	9.6	8.1	8.2	7.3	6.5	7.2	6.4	5.8	6.8	6.1	5.5
40.0	11.2	9.2	7.7	10.2	9.2	7.9	7.8	7.1	6.3	6.9	6.1	5.6	6.5	5.8	5.3
42.0	10.0	8.9	7.6	9.8	8.9	7.7	7.5	6.8	6.2	6.5	5.9	5.4	6.1	5.6	5.1
44.0	8.9	8.6	7.5	8.9	8.6	7.6	7.1	6.5	6.0	6.2	5.7	5.2	5.8	5.4	4.9
46.0	8.0	8.4	7.4	7.9	8.3	7.5	6.8	6.3	5.8	5.9	5.5	5.0	5.4	5.1	4.7
48.0	7.1	8.1	7.3	7.0	8.0	7.4	6.6	6.0	5.7	5.7	5.3	4.9	5.0	4.8	4.5
50.0	6.2	7.2	7.2	6.1	7.3	7.3	6.3	5.8	5.5	5.4	5.1	4.7	4.6	4.4	4.3
54.0	4.8	5.6	6.0	4.7	5.6	6.2	4.9	5.4	5.2	4.8	4.6	4.4	4.0	3.9	3.9
58.0	3.6	4.1		3.5	4.2	4.6	3.6	4.5	4.9	3.8	4.1	4.0	3.4	3.4	3.4
62.0	2.6			2.5	3.0		2.6	3.3	3.6	2.7	3.5	3.6	2.5	2.9	3.0
66.0				1.6	1.9		1.7	2.2		1.8	2.4	2.7	1.5	2.3	2.6
70.0											1.5				
θ(°)	16~83	33~84.5	45~84.5	19~83	25~84.5	45~84.5	29~83	35~84.5	45~84.5	36~83	36~84.5	45~84.5	41~83	47~84.5	50~84.5
標準フック フック重量	35t 950kg						35t 950kg								
標準巻掛本数	3						2								

カウンタウエイト 78t、アウトリガ張出幅 8.0m

ブーム+2.0m+29.5m油圧チルトジブ

単位:t

ブーム長さ(m) 作業半径 (m)	40.4			45.4			50.5			55.6			60.0		
	オフセット			オフセット			オフセット			オフセット			オフセット		
	0°	20°	40°	0°	20°	40°	0°	20°	40°	0°	20°	40°	0°	20°	40°
14.0	20.4			18.9											
16.0	19.0			17.7			14.7								
18.0	17.8			16.7			13.6			12.4					
20.0	16.7			15.7			12.6			11.4			10.9		
22.0	15.8			14.9			11.7			10.6			10.1		
24.0	14.9	10.2		14.1	10.5		11.0			9.9			9.5		
26.0	14.1	9.6		13.4	9.9		10.3	8.2		9.3			8.9		
28.0	13.4	9.1		12.7	9.4		9.8	7.8		8.7	7.2		8.3		
30.0	12.8	8.7		11.9	9.0		9.2	7.4		8.2	6.8		7.9	6.5	
32.0	12.2	8.3	6.2	11.3	8.6	6.3	8.7	7.1		7.8	6.5		7.4	6.2	
34.0	11.4	7.9	6.0	10.7	8.2	6.1	8.2	6.8	5.9	7.4	6.2		7.0	5.9	
36.0	10.7	7.6	5.9	10.2	7.9	6.0	7.8	6.5	5.7	7.0	5.9	5.3	6.7	5.5	
38.0	10.0	7.2	5.7	9.7	7.5	5.8	7.4	6.3	5.5	6.7	5.7	5.1	6.3	5.2	4.4
40.0	9.5	6.9	5.5	9.2	7.2	5.6	7.0	6.0	5.3	6.4	5.4	4.9	5.9	4.9	4.2
42.0	8.9	6.7	5.4	8.8	7.0	5.5	6.7	5.8	5.1	6.0	5.2	4.7	5.4	4.6	4.0
44.0	8.5	6.4	5.3	8.4	6.7	5.4	6.4	5.6	5.0	5.7	5.0	4.5	5.0	4.3	3.8
46.0	8.0	6.2	5.1	8.0	6.5	5.2	6.1	5.4	4.8	5.4	4.8	4.3	4.6	4.1	3.6
48.0	7.2	6.0	5.0	7.1	6.3	5.1	5.8	5.2	4.7	5.1	4.6	4.2	4.2	3.9	3.4
50.0	6.4	5.8	5.0	6.2	6.1	5.0	5.5	5.1	4.6	4.7	4.4	4.1	3.9	3.6	3.3
54.0	4.9	5.4	4.8	4.8	5.7	4.9	4.9	4.5	4.3	4.1	3.9	3.8	3.3	3.2	3.0
58.0	3.7	4.6	4.8	3.6	4.6	4.8	3.6	4.1	3.9	3.6	3.4	3.3	2.8	2.7	2.7
62.0	2.7	3.4		2.5	3.4	3.9	2.6	3.5	3.5	2.8	3.0	2.9	2.3	2.3	2.4
66.0	1.8	2.2		1.6	2.3		1.7	2.5	3.0	1.9	2.6	2.6	1.7	1.9	2.0
70.0								1.5			1.8	2.3		1.6	1.7
θ(°)	21~ 83	29~ 84.5	49~ 84.5	31~ 83	39~ 84.5	49~ 84.5	37~ 83	39~ 84.5	49~ 84.5	42~ 83	45~ 84.5	49~ 84.5	46~ 83	49~ 84.5	53~ 84.5
標準フック	35t												12.2t		
フック重量	950kg												440kg		
標準巻掛本数	2												1		

カウンタウエイト 78t、アウトリガ張出幅 8.0m

ブーム+2.0m+35.5m油圧チルトジブ

単位:t

ブーム長さ(m) 作業半径 (m)	40.4			45.4			50.5			55.6			60.0		
	オフセット			オフセット			オフセット			オフセット			オフセット		
	0°	20°	40°	0°	20°	40°	0°	20°	40°	0°	20°	40°	0°	20°	40°
14.0	17.2														
16.0	16.2			15.1											
18.0	15.3			14.3			12.9								
20.0	14.5			13.6			12.0			10.6					
22.0	13.7			12.9			11.1			9.8			9.4		
24.0	12.8			12.3			10.4			9.2			8.7		
26.0	12.0	7.9		11.7			9.8			8.6			8.2		
28.0	11.3	7.5		11.1	7.7		9.2			8.0			7.7		
30.0	10.7	7.1		10.6	7.3		8.7	6.8		7.5			7.2		
32.0	10.1	6.7		10.1	6.9		8.2	6.5		7.1	5.8		6.8	5.4	
34.0	9.6	6.4		9.7	6.6		7.8	6.2		6.7	5.6		6.4	5.0	
36.0	8.9	6.1	4.5	9.2	6.3		7.4	5.9		6.4	5.3		6.1	4.7	
38.0	8.4	5.8	4.3	8.8	6.0	4.4	7.0	5.7		6.0	5.0		5.8	4.4	
40.0	7.9	5.5	4.2	8.4	5.7	4.2	6.7	5.5	4.5	5.7	4.8		5.3	4.1	
42.0	7.4	5.3	4.0	8.0	5.5	4.1	6.3	5.2	4.4	5.5	4.6	4.1	4.9	3.9	3.3
44.0	7.0	5.0	3.9	7.5	5.3	4.0	6.0	5.0	4.3	5.2	4.4	3.9	4.5	3.6	3.1
46.0	6.6	4.8	3.8	7.1	5.0	3.9	5.7	4.8	4.1	4.8	4.2	3.7	4.1	3.4	2.9
48.0	6.2	4.6	3.7	6.7	4.8	3.7	5.4	4.7	4.0	4.5	4.0	3.5	3.7	3.2	2.7
50.0	5.9	4.4	3.6	6.4	4.7	3.7	5.1	4.5	3.9	4.1	3.8	3.3	3.4	3.0	2.6
54.0	5.2	4.1	3.4	5.0	4.3	3.5	4.5	4.1	3.7	3.6	3.4	3.0	2.8	2.6	2.3
58.0	4.0	3.8	3.3	3.8	4.0	3.3	3.9	3.6	3.4	3.0	2.9	2.7	2.3	2.3	2.0
62.0	2.9	3.6	3.2	2.7	3.8	3.2	2.9	3.2	3.0	2.6	2.5	2.4	1.9	1.9	1.8
66.0	2.0	2.8	3.2	1.8	2.8	3.2	2.0	2.8	2.7	2.0	2.1	2.1	1.5	1.6	1.6
70.0		1.8			1.8	2.3		2.1	2.4		1.8	1.8			
74.0								1.6				1.5			
θ(°)	32~ 83	34~ 84.5	46~ 84.5	38~ 83	42~ 84.5	47~ 84.5	43~ 83	47~ 84.5	47~ 84.5	47~ 83	52~ 84.5	53~ 84.5	50~ 83	58~ 84.5	63~ 84.5
標準フック	35t												12.2t		
フック重量	950kg												440kg		
標準巻掛本数	2												1		

油圧チルトジブ

カウンタウエイト 78t、アウトリガ張出幅 8.0m

ブーム+2.0m+41.5m油圧チルトジブ

単位:t

ブーム長さ(m) 作業半径 (m)	40.4			45.4			50.5			55.6			60.0		
	オフセット			オフセット			オフセット			オフセット			オフセット		
	0°	20°	40°	0°	20°	40°	0°	20°	40°	0°	20°	40°	0°	20°	40°
16.0	13.4			12.3											
18.0	12.7			11.7			10.5								
20.0	12.0			11.1			10.0					8.9			
22.0	11.3			10.5			9.6					8.6			
24.0	10.6			10.0			9.2					8.2			7.7
26.0	10.0			9.5			8.8					7.7			7.3
28.0	9.3			9.1			8.2					7.2			6.8
30.0	8.8	5.8		8.7			7.7					6.7			6.4
32.0	8.3	5.4		8.3	5.6		7.3					6.3			6.0
34.0	7.8	5.1		7.9	5.3		6.9	5.4				5.9			5.6
36.0	7.4	4.8		7.5	5.0		6.5	5.1				5.6	4.6		5.1 3.7
38.0	7.0	4.5		7.1	4.7		6.1	4.9				5.3	4.3		4.7 3.4
40.0	6.5	4.2		6.7	4.4		5.8	4.6				5.0	4.0		4.3 3.1
42.0	6.1	4.0	2.8	6.4	4.2		5.5	4.4				4.6	3.7		3.9 2.9
44.0	5.7	3.8	2.6	6.1	4.0	2.7	5.1	4.1				4.2	3.4		3.6 2.7
46.0	5.3	3.6	2.5	5.8	3.8	2.6	4.8	3.9	2.6			3.8	3.2		3.3 2.5
48.0	4.9	3.4	2.4	5.4	3.6	2.5	4.4	3.7	2.5	3.5	3.0	2.5	2.9	2.3	1.9
50.0	4.6	3.2	2.3	5.1	3.4	2.4	4.1	3.5	2.4	3.2	2.7	2.3	2.6	2.1	1.7
54.0	4.1	2.9	2.1	4.5	3.1	2.2	3.5	3.1	2.3	2.6	2.4	2.0	2.4	2.0	1.7
58.0	3.6	2.6	2.0	3.8	2.8	2.0	3.0	2.7	2.1	2.1	2.0	1.7	1.6		
62.0	2.9	2.3	1.8	2.7	2.5	1.9	2.5	2.3	2.0	1.7	1.6				
66.0	2.0	2.1	1.7	1.7	2.3	1.8	1.7	1.9	1.8						
70.0		1.9	1.7		2.0	1.7		1.6	1.5						
74.0					1.7										
θ(°)	39~ 83	44~ 84.5	51~ 84.5	44~ 83	49~ 84.5	51~ 84.5	47~ 83	54~ 84.5	60~ 84.5	54~ 83	63~ 84.5	73~ 84.5	59~ 83	70~ 84.5	80~ 84.5
標準フック	35t						12.2t								
フック重量	950kg						440kg								
標準巻掛本数	2						1								

カウンタウエイト 78t、アウトリガ張出幅 8.0m

ブーム+2.0m+47.5m油圧チルトジブ

単位:t

ブーム長さ(m) 作業半径 (m)	40.4		45.4		50.5		55.6		60.0			
	オフセット		オフセット		オフセット		オフセット		オフセット			
	0°	20°	0°	20°	0°	20°	0°	20°	0°	20°		
16.0	10.7											
18.0	10.1		9.3									
20.0	9.6		8.8		7.8							
22.0	9.0		8.3		7.5		6.5					
24.0	8.5		7.9		7.1		6.3					
26.0	8.1		7.5		6.8		6.0		5.6			
28.0	7.6		7.1		6.5		5.8		5.4			
30.0	7.2		6.8		6.2		5.6		5.2			
32.0	6.7		6.5		5.9		5.3		4.9			
34.0	6.3	3.7	6.2		5.6		5.1		4.7			
36.0	5.9	3.5	5.9	3.6	5.4		4.9		4.2			
38.0	5.4	3.2	5.6	3.4	5.2	3.5	4.6		3.8			
40.0	5.0	3.0	5.3	3.1	4.9	3.3	4.2	3.1	3.5			
42.0	4.6	2.8	5.0	2.9	4.7	3.1	3.8	2.8	3.1	2.1		
44.0	4.3	2.6	4.7	2.7	4.4	2.9	3.5	2.6	2.8	1.9		
46.0	4.0	2.4	4.3	2.6	4.0	2.7	3.2	2.4	2.5	1.7		
48.0	3.7	2.3	4.0	2.4	3.6	2.5	2.8	2.1	2.2	1.5		
50.0	3.4	2.1	3.7	2.2	3.3	2.4	2.5	1.9	2.0			
54.0	2.9	1.8	3.2	1.9	2.7	2.1	2.0	1.5	1.5			
58.0	2.5	1.6	2.8	1.7	2.2	1.8	1.5					
62.0	2.1		2.4	1.5	1.8	1.6						
66.0	1.8		1.7									
θ(°)	44~ 84.5	62~ 84.5	48~ 84.5	62~ 84.5	54~ 84.5	65~ 84.5	60~ 84.5	72~ 84.5	64~ 84.5	77~ 84.5		
標準フック	12.2t											
フック重量	440kg											
標準巻掛本数	1											

カウンタウエイト 78t、アウトリガ張出幅 6.8m

ブーム+2.0m+3.5m油圧チルトジブ

単位:t

ブーム長さ(m) 作業半径 (m)	40.4			45.4			50.5			55.6			60.0		
	オフセット			オフセット			オフセット			オフセット			オフセット		
	0°	20°	40°	0°	20°	40°	0°	20°	40°	0°	20°	40°	0°	20°	40°
8.0	47.7														
9.0	44.9			38.0											
10.0	42.5	40.3	38.9	36.1	33.9			28.4							
11.0	40.3	38.4	37.1	34.4	32.4	31.1	27.0	25.5		23.9					
12.0	38.3	36.6	35.5	32.9	31.1	29.9	25.7	24.4	23.5	22.8	21.5				
14.0	35.0	33.6	32.7	30.3	28.8	27.8	23.6	22.5	21.7	20.8	19.9	19.2	19.7		
16.0	32.2	31.0	30.3	28.1	26.8	26.0	21.8	20.9	20.3	19.2	18.5	18.0	18.2	17.5	17.1
18.0	29.9	28.9	28.3	26.0	25.1	24.4	20.3	19.5	19.0	17.8	17.2	16.8	16.9	16.3	15.9
20.0	27.9	27.0	26.5	24.2	23.6	23.1	19.0	18.3	17.9	16.6	16.1	15.8	15.7	15.2	14.9
22.0	25.2	25.4	25.0	22.6	22.1	21.8	17.9	17.3	16.9	15.6	15.1	14.8	14.7	14.3	14.1
24.0	21.7	22.1	22.3	21.3	20.8	20.6	16.9	16.3	16.0	14.7	14.3	14.0	13.9	13.5	13.3
26.0	18.8	19.1	19.3	19.1	19.4	19.5	16.0	15.5	15.2	13.9	13.5	13.3	13.1	12.8	12.6
28.0	16.4	16.7	16.8	16.7	17.0	17.2	15.2	14.8	14.6	13.1	12.8	12.6	12.4	12.1	12.0
30.0	14.4	14.6	14.7	14.6	14.9	15.1	14.5	14.1	13.9	12.5	12.2	12.1	11.8	11.5	11.4
32.0	12.6	12.8	12.9	12.9	13.1	13.2	13.5	13.6	13.4	11.9	11.7	11.5	11.2	11.0	10.9
34.0	10.9	11.1	11.2	11.3	11.5	11.7	11.9	12.2	12.3	11.4	11.2	11.0	10.7	10.5	10.4
36.0	9.4	9.6		9.8	10.0	10.1	10.5	10.7	10.9	10.9	10.7	10.6	10.3	10.1	10.0
38.0	8.1	8.3		8.5	8.7	8.7	9.2	9.4	9.5	9.8	10.0	10.1	9.8	9.7	9.6
40.0	7.0	7.1		7.3	7.4		8.0	8.2	8.2	8.6	8.8	8.9	8.7	8.9	9.0
42.0	6.0			6.3	6.4		6.9	7.1	7.1	7.5	7.7	7.8	7.6	7.8	7.9
44.0	5.1			5.3	5.4		6.0	6.1		6.6	6.7	6.8	6.6	6.8	6.9
46.0				4.5	4.5		5.1	5.2		5.7	5.8	5.9	5.7	5.9	5.9
48.0				3.8			4.4	4.4		4.9	5.0		4.9	5.1	5.1
50.0							3.7	3.7		4.2	4.3		4.2	4.3	
54.0							2.5			3.0	3.0		2.9	3.0	
58.0										1.9			1.9	1.9	
θ(°)	0~ 84.5	27~ 84.5	43~ 84.5	13~ 84.5	23~ 84.5	42~ 84.5	0~ 84.5	25~ 84.5	42~ 84.5	13~ 84.5	27~ 84.5	42~ 84.5	27~ 84.5	27~ 84.5	45~ 84.5
標準フック	80t			80t						35t					
フック重量	1550kg			1550kg						950kg					
標準巻掛本数	5			4						3					

カウンタウエイト 78t、アウトリガ張出幅 6.8m

ブーム+2.0m+11.5m油圧チルトジブ

単位:t

ブーム長さ(m) 作業半径 (m)	40.4			45.4			50.5			55.6			60.0		
	オフセット			オフセット			オフセット			オフセット			オフセット		
	0°	20°	40°	0°	20°	40°	0°	20°	40°	0°	20°	40°	0°	20°	40°
10.0	38.8														
11.0	36.7			31.1											
12.0	34.8			29.6			23.3								
14.0	31.5	27.6		27.0	23.4		21.2			18.8					
16.0	28.9	26.1	22.7	24.8	21.8		19.4	16.7		17.4	14.9		15.6		
18.0	26.6	24.2	21.8	23.0	20.4	18.8	18.0	15.8	14.0	16.0	14.0		15.1		
20.0	24.7	22.6	21.0	21.5	19.2	17.8	16.7	15.0	13.4	14.9	13.2	12.0	14.0	12.5	
22.0	23.0	21.3	20.1	20.1	18.1	16.9	15.6	14.1	12.8	13.9	12.5	11.4	13.1	11.9	
24.0	21.6	20.0	19.0	18.9	17.2	16.1	14.7	13.3	12.3	13.0	11.9	10.9	12.3	11.3	10.4
26.0	19.5	18.9	18.1	17.9	16.3	15.3	13.8	12.6	11.9	12.2	11.3	10.5	11.5	10.7	9.9
28.0	17.1	18.0	17.2	17.0	15.5	14.7	13.1	12.0	11.4	11.5	10.8	10.0	10.9	10.2	9.5
30.0	15.1	16.1	16.4	15.3	14.9	14.1	12.4	11.4	10.9	10.9	10.2	9.7	10.3	9.7	9.2
32.0	13.3	14.2	14.9	13.5	14.2	13.5	11.8	10.9	10.4	10.3	9.7	9.3	9.7	9.2	8.8
34.0	11.8	12.6	13.2	12.0	12.8	13.1	11.2	10.4	10.0	9.8	9.3	8.9	9.3	8.7	8.4
36.0	10.3	11.2	11.7	10.5	11.4	12.0	10.7	10.0	9.6	9.4	8.9	8.5	8.8	8.4	8.1
38.0	9.0	9.8	10.3	9.2	10.1	10.6	9.6	9.6	9.3	9.0	8.5	8.2	8.4	8.0	7.7
40.0	7.8	8.5	8.9	8.0	8.8	9.3	8.4	9.2	8.9	8.6	8.1	7.9	8.0	7.7	7.4
42.0	6.8	7.4	7.7	7.0	7.7	8.1	7.3	8.1	8.6	7.8	7.8	7.6	7.6	7.3	7.1
44.0	5.8	6.4		6.0	6.6	7.0	6.4	7.1	7.5	6.8	7.5	7.3	6.7	7.1	6.9
46.0	5.0	5.4		5.2	5.7	6.0	5.5	6.1	6.5	6.0	6.6	7.0	5.8	6.5	6.6
48.0	4.3	4.6		4.4	4.9		4.7	5.3	5.6	5.2	5.8	6.1	5.0	5.6	6.1
50.0	3.6			3.7	4.1		4.0	4.5	4.7	4.5	5.0	5.3	4.3	4.9	5.2
54.0				2.5	2.7		2.8	3.1		3.2	3.6	3.8	3.0	3.5	3.8
58.0							1.8	2.0		2.1	2.4		1.9	2.3	
θ(°)	17~ 83	28~ 84.5	44~ 84.5	20~ 83	24~ 84.5	44~ 84.5	22~ 83	26~ 84.5	43~ 84.5	32~ 83	36~ 84.5	43~ 84.5	38~ 83	41~ 84.5	48~ 84.5
標準フック	80t									35t					
フック重量	1550kg									950kg					
標準巻掛本数	4									3					

油圧チルトジブ

カウンタウエイト 78t、アウトリガ張出幅 6.8m

ブーム+2.0m+17.5m油圧チルトジブ

単位:t

ブーム長さ(m) 作業半径 (m)	40.4			45.4			50.5			55.6			60.0		
	オフセット			オフセット			オフセット			オフセット			オフセット		
	0°	20°	40°	0°	20°	40°	0°	20°	40°	0°	20°	40°	0°	20°	40°
11.0	31.5														
12.0	30.3			27.0											
14.0	28.1			24.6					19.5						
16.0	26.3	20.6		22.6					17.9			15.6			14.8
18.0	24.6	19.5		20.8	17.9				16.5	13.4		14.5			13.7
20.0	22.8	18.6		19.4	16.8				15.3	12.7		13.5	11.3		12.8
22.0	21.2	17.8	14.0	18.1	15.8				14.3	12.0		12.6	10.7		12.0
24.0	19.9	17.1	13.6	17.0	15.0	13.7			13.4	11.5	10.1	11.9	10.1		11.2
26.0	18.6	16.4	13.3	16.0	14.2	13.1	12.5	11.0	9.7	11.1	9.6	8.7	10.5	9.2	8.3
28.0	17.6	15.8	12.9	15.1	13.5	12.5	11.8	10.5	9.3	10.5	9.2	8.3	9.9	8.7	7.9
30.0	15.6	15.3	12.7	14.4	12.9	12.0	11.2	10.1	9.0	9.9	8.8	8.0	9.3	8.4	7.6
32.0	13.8	14.6	12.4	13.6	12.3	11.5	10.6	9.6	8.7	9.3	8.4	7.7	8.8	8.0	7.3
34.0	12.3	13.5	12.2	12.3	11.8	11.1	10.1	9.2	8.5	8.8	8.1	7.4	8.3	7.7	7.1
36.0	10.9	12.1	12.0	10.9	11.3	10.6	9.6	8.8	8.2	8.4	7.7	7.1	7.9	7.4	6.8
38.0	9.6	10.8	11.5	9.6	10.8	10.3	9.2	8.4	8.0	8.0	7.4	6.9	7.5	7.0	6.6
40.0	8.4	9.6	10.3	8.4	9.6	9.9	8.8	8.1	7.7	7.6	7.1	6.7	7.2	6.7	6.4
42.0	7.3	8.4	9.1	7.3	8.4	9.3	7.7	7.8	7.4	7.3	6.8	6.5	6.9	6.4	6.2
44.0	6.3	7.3	7.9	6.3	7.4	8.1	6.7	7.5	7.1	6.9	6.5	6.3	6.5	6.2	6.0
46.0	5.5	6.3	6.8	5.5	6.4	7.0	5.8	6.8	6.9	6.1	6.3	6.1	5.9	5.9	5.7
48.0	4.7	5.4	5.8	4.7	5.5	6.1	5.0	6.0	6.6	5.3	6.0	5.9	5.1	5.6	5.5
50.0	4.0	4.6		4.0	4.7	5.2	4.3	5.1	5.7	4.5	5.4	5.6	4.3	5.3	5.3
54.0	2.8	3.2		2.7	3.3		3.1	3.7	4.1	3.3	4.0	4.5	3.1	3.8	4.4
58.0				1.7	2.1		2.0	2.5		2.2	2.8	3.1	2.0	2.6	3.0
62.0										1.7			1.6		1.9
θ(°)	23~ 83	28~ 84.5	44~ 84.5	25~ 83	30~ 84.5	48~ 84.5	34~ 83	38~ 84.5	47~ 84.5	40~ 83	39~ 84.5	47~ 84.5	44~ 83	44~ 84.5	46~ 84.5
標準フック	35t						35t								
フック重量	950kg						950kg								
標準巻掛本数	3						2								

カウンタウエイト 78t、アウトリガ張出幅 6.8m

ブーム+2.0m+23.5m油圧チルトジブ

単位:t

ブーム長さ(m) 作業半径 (m)	40.4			45.4			50.5			55.6			60.0		
	オフセット			オフセット			オフセット			オフセット			オフセット		
	0°	20°	40°	0°	20°	40°	0°	20°	40°	0°	20°	40°	0°	20°	40°
12.0	25.7														
14.0	23.9			22.1					17.6						
16.0	22.2			20.7					16.2			14.2			
18.0	20.8			19.3					15.0			13.1			12.4
20.0	19.6	14.4		17.9					14.0			12.2			11.6
22.0	18.5	13.6		16.7	13.8				13.1	10.3		11.4			10.8
24.0	17.5	12.9		15.6	13.2				12.2	9.8		10.6	8.8		10.1
26.0	16.6	12.3	9.3	14.7	12.6				11.4	9.4		10.0	8.3	9.5	8.0
28.0	15.8	11.7	9.0	13.8	12.1	9.1	10.7	9.0		9.4	7.9		9.0	7.6	
30.0	15.1	11.2	8.7	13.1	11.5	8.9	10.1	8.6	7.5	8.9	7.6	6.7	8.5	7.2	
32.0	14.2	10.7	8.5	12.4	11.0	8.6	9.6	8.2	7.2	8.5	7.2	6.5	8.0	6.9	6.2
34.0	12.7	10.3	8.3	11.8	10.5	8.4	9.1	7.9	7.0	8.0	6.9	6.2	7.6	6.6	6.0
36.0	11.3	9.9	8.1	11.2	10.0	8.2	8.6	7.6	6.8	7.6	6.6	6.0	7.2	6.3	5.7
38.0	10.0	9.6	7.9	9.9	9.6	8.1	8.2	7.3	6.5	7.2	6.4	5.8	6.8	6.1	5.5
40.0	8.8	9.2	7.7	8.7	9.2	7.9	7.8	7.1	6.3	6.9	6.1	5.6	6.5	5.8	5.3
42.0	7.7	8.9	7.6	7.7	8.9	7.7	7.5	6.8	6.2	6.5	5.9	5.4	6.1	5.6	5.1
44.0	6.8	8.1	7.5	6.7	8.1	7.6	6.9	6.5	6.0	6.2	5.7	5.2	5.8	5.4	4.9
46.0	5.9	7.1	7.4	5.8	7.1	7.5	6.0	6.3	5.8	5.9	5.5	5.0	5.4	5.1	4.7
48.0	5.1	6.2	7.0	5.0	6.2	7.1	5.2	6.0	5.7	5.3	5.3	4.9	5.0	4.8	4.5
50.0	4.4	5.4	6.1	4.3	5.4	6.2	4.4	5.6	5.5	4.6	5.1	4.7	4.3	4.4	4.3
54.0	3.1	3.9	4.3	3.0	3.9	4.5	3.2	4.2	4.8	3.3	4.3	4.4	3.1	3.9	3.9
58.0	2.0	2.6		1.9	2.7	3.0	2.1	2.9	3.4	2.2	3.1	3.7	2.0	2.9	3.4
62.0					1.5			1.8	2.1		2.0	2.5		1.8	2.4
θ(°)	27~ 83	33~ 84.5	45~ 84.5	35~ 83	35~ 84.5	45~ 84.5	41~ 83	42~ 84.5	45~ 84.5	45~ 83	47~ 84.5	51~ 84.5	49~ 83	51~ 84.5	55~ 84.5
標準フック	35t						35t								
フック重量	950kg						950kg								
標準巻掛本数	3						2								

カウンタウエイト 78t、アウトリガ張出幅 6.8m

ブーム+2.0m+29.5m油圧チルトジブ

単位:t

ブーム長さ(m) 作業半径 (m)	40.4			45.4			50.5			55.6			60.0		
	オフセット			オフセット			オフセット			オフセット			オフセット		
	0°	20°	40°	0°	20°	40°	0°	20°	40°	0°	20°	40°	0°	20°	40°
14.0	20.4			18.9											
16.0	19.0			17.7			14.7								
18.0	17.8			16.7			13.6					12.4			
20.0	16.7			15.7			12.6					11.4			10.9
22.0	15.8			14.9			11.7					10.6			10.1
24.0	14.9	10.2		14.1	10.5		11.0					9.9			9.5
26.0	14.1	9.6		13.4	9.9		10.3	8.2				9.3			8.9
28.0	13.4	9.1		12.7	9.4		9.8	7.8				8.7	7.2		8.3
30.0	12.8	8.7		11.9	9.0		9.2	7.4				8.2	6.8	7.9	6.5
32.0	12.2	8.3	6.2	11.3	8.6	6.3	8.7	7.1				7.8	6.5	7.4	6.2
34.0	11.4	7.9	6.0	10.7	8.2	6.1	8.2	6.8	5.9			7.4	6.2	7.0	5.9
36.0	10.7	7.6	5.9	10.2	7.9	6.0	7.8	6.5	5.7	7.0	5.9	5.3	6.7	5.5	
38.0	10.0	7.2	5.7	9.7	7.5	5.8	7.4	6.3	5.5	6.7	5.7	5.1	6.3	5.2	4.4
40.0	9.0	6.9	5.5	8.9	7.2	5.6	7.0	6.0	5.3	6.4	5.4	4.9	5.9	4.9	4.2
42.0	7.9	6.7	5.4	7.8	7.0	5.5	6.7	5.8	5.1	6.0	5.2	4.7	5.4	4.6	4.0
44.0	6.9	6.4	5.3	6.8	6.7	5.4	6.4	5.6	5.0	5.7	5.0	4.5	5.0	4.3	3.8
46.0	6.1	6.2	5.1	5.9	6.5	5.2	6.0	5.4	4.8	5.4	4.8	4.3	4.6	4.1	3.6
48.0	5.3	6.0	5.0	5.1	6.3	5.1	5.2	5.2	4.7	5.1	4.6	4.2	4.2	3.9	3.4
50.0	4.5	5.8	5.0	4.4	5.8	5.0	4.5	5.1	4.6	4.7	4.4	4.1	3.9	3.6	3.3
54.0	3.2	4.4	4.8	3.1	4.3	4.9	3.2	4.5	4.3	3.5	3.9	3.8	3.2	3.2	3.0
58.0	2.2	3.1	3.7	2.0	3.0	3.8	2.1	3.2	3.9	2.3	3.4	3.3	2.1	2.7	2.7
62.0		1.9			1.9	2.5		2.1	2.8		2.4	2.9		2.2	2.4
66.0									1.6			2.0			1.9
θ(°)	36~ 83	38~ 84.5	49~ 84.5	42~ 83	45~ 84.5	49~ 84.5	46~ 83	49~ 84.5	49~ 84.5	50~ 83	54~ 84.5	54~ 84.5	53~ 83	57~ 84.5	57~ 84.5
標準フック	35t												12.2t		
フック重量	950kg												440kg		
標準巻掛本数	2												1		

カウンタウエイト 78t、アウトリガ張出幅 6.8m

ブーム+2.0m+35.5m油圧チルトジブ

単位:t

ブーム長さ(m) 作業半径 (m)	40.4			45.4			50.5			55.6			60.0		
	オフセット			オフセット			オフセット			オフセット			オフセット		
	0°	20°	40°	0°	20°	40°	0°	20°	40°	0°	20°	40°	0°	20°	40°
14.0	17.2														
16.0	16.2			15.1											
18.0	15.3			14.3			12.9								
20.0	14.5			13.6			12.0					10.6			
22.0	13.7			12.9			11.1					9.8			9.4
24.0	12.8			12.3			10.4					9.2			8.7
26.0	12.0	7.9		11.7			9.8					8.6			8.2
28.0	11.3	7.5		11.1	7.7		9.2					8.0			7.7
30.0	10.7	7.1		10.6	7.3		8.7	6.8				7.5			7.2
32.0	10.1	6.7		10.1	6.9		8.2	6.5			7.1	5.8		6.8	5.4
34.0	9.6	6.4		9.7	6.6		7.8	6.2			6.7	5.6		6.4	5.0
36.0	8.9	6.1	4.5	9.2	6.3		7.4	5.9			6.4	5.3		6.1	4.7
38.0	8.4	5.8	4.3	8.8	6.0	4.4	7.0	5.7			6.0	5.0		5.8	4.4
40.0	7.9	5.5	4.2	8.4	5.7	4.2	6.7	5.5	4.5		5.7	4.8		5.3	4.1
42.0	7.4	5.3	4.0	8.0	5.5	4.1	6.3	5.2	4.4	5.5	4.6	4.1		4.9	3.9
44.0	7.0	5.0	3.9	7.0	5.3	4.0	6.0	5.0	4.3	5.2	4.4	3.9		4.5	3.6
46.0	6.3	4.8	3.8	6.1	5.0	3.9	5.7	4.8	4.1	4.8	4.2	3.7		4.1	3.4
48.0	5.5	4.6	3.7	5.3	4.8	3.7	5.4	4.7	4.0	4.5	4.0	3.5		3.7	3.2
50.0	4.8	4.4	3.6	4.6	4.7	3.7	4.9	4.5	3.9	4.1	3.8	3.3		3.4	3.0
54.0	3.5	4.1	3.4	3.3	4.3	3.5	3.6	4.1	3.7	3.6	3.4	3.0		2.8	2.6
58.0	2.4	3.6	3.3	2.2	3.6	3.3	2.4	3.6	3.4	2.5	2.9	2.7		2.2	2.3
62.0	1.5	2.5	3.2		2.4	3.2	1.5	2.7	3.0		2.5	2.4		1.9	1.8
66.0		1.5	2.0			2.1		1.7	2.5		1.8	2.1			1.6
θ(°)	37~ 83	41~ 84.5	46~ 84.5	47~ 83	52~ 84.5	53~ 84.5	47~ 83	52~ 84.5	58~ 84.5	54~ 83	56~ 84.5	61~ 84.5	56~ 83	61~ 84.5	63~ 84.5
標準フック	35t												12.2t		
フック重量	950kg												440kg		
標準巻掛本数	2												1		

油圧チルトジブ

カウンタウエイト 78t、アウトリガ張出幅 6.8m

ブーム+2.0m+41.5m油圧チルトジブ

単位:t

ブーム長さ(m) 作業半径 (m)	40.4			45.4			50.5			55.6			60.0		
	オフセット			オフセット			オフセット			オフセット			オフセット		
	0°	20°	40°	0°	20°	40°	0°	20°	40°	0°	20°	40°	0°	20°	40°
16.0	13.4			12.3											
18.0	12.7			11.7			10.5								
20.0	12.0			11.1			10.0					8.9			
22.0	11.3			10.5			9.6				8.6				
24.0	10.6			10.0			9.2				8.2			7.7	
26.0	10.0			9.5			8.8				7.7			7.3	
28.0	9.3			9.1			8.2				7.2			6.8	
30.0	8.8	5.8		8.7			7.7				6.7			6.4	
32.0	8.3	5.4		8.3	5.6		7.3				6.3			6.0	
34.0	7.8	5.1		7.9	5.3		6.9	5.4			5.9			5.6	
36.0	7.4	4.8		7.5	5.0		6.5	5.1			5.6	4.6		5.1	3.7
38.0	7.0	4.5		7.1	4.7		6.1	4.9			5.3	4.3		4.7	3.4
40.0	6.5	4.2		6.7	4.4		5.8	4.6			5.0	4.0		4.3	3.1
42.0	6.1	4.0	2.8	6.4	4.2		5.5	4.4			4.6	3.7		3.9	2.9
44.0	5.7	3.8	2.6	6.1	4.0	2.7	5.1	4.1			4.2	3.4		3.6	2.7
46.0	5.3	3.6	2.5	5.8	3.8	2.6	4.8	3.9	2.6		3.8	3.2		3.3	2.5
48.0	4.9	3.4	2.4	5.4	3.6	2.5	4.4	3.7	2.5	3.5	3.0	2.5	2.9	2.3	1.9
50.0	4.6	3.2	2.3	4.6	3.4	2.4	4.1	3.5	2.4	3.2	2.7	2.3	2.6	2.1	1.7
54.0	3.5	2.9	2.1	3.3	3.1	2.2	3.3	3.1	2.3	2.6	2.4	2.0	2.1	1.7	
58.0	2.4	2.6	2.0	2.2	2.8	2.0	2.2	2.7	2.1		2.0	1.7			
62.0		2.3	1.8		2.5	1.9		2.3	2.0		1.6				
66.0		1.7	1.7		1.6	1.8			1.8						
θ(°)	47~ 83	49~ 84.5	56~ 84.5	51~ 83	53~ 84.5	61~ 84.5	54~ 83	61~ 84.5	64~ 84.5	60~ 83	63~ 84.5	73~ 84.5	62~ 83	70~ 84.5	80~ 84.5
標準フック	35t						12.2t								
フック重量	950kg						440kg								
標準巻掛本数	2						1								

カウンタウエイト 78t、アウトリガ張出幅 6.8m

ブーム+2.0m+47.5m油圧チルトジブ

単位:t

ブーム長さ(m) 作業半径 (m)	40.4		45.4		50.5		55.6		60.0	
	オフセット		オフセット		オフセット		オフセット		オフセット	
	0°	20°	0°	20°	0°	20°	0°	20°	0°	20°
16.0	10.7									
18.0	10.1		9.3							
20.0	9.6		8.8		7.8					
22.0	9.0		8.3		7.5		6.5			
24.0	8.5		7.9		7.1		6.3			
26.0	8.1		7.5		6.8		6.0		5.6	
28.0	7.6		7.1		6.5		5.8		5.4	
30.0	7.2		6.8		6.2		5.6		5.2	
32.0	6.7		6.5		5.9		5.3		4.9	
34.0	6.3	3.7	6.2		5.6		5.1		4.7	
36.0	5.9	3.5	5.9	3.6	5.4		4.9		4.2	
38.0	5.4	3.2	5.6	3.4	5.2	3.5	4.6		3.8	
40.0	5.0	3.0	5.3	3.1	4.9	3.3	4.2	3.1	3.5	
42.0	4.6	2.8	5.0	2.9	4.7	3.1	3.8	2.8	3.1	2.1
44.0	4.3	2.6	4.7	2.7	4.4	2.9	3.5	2.6	2.8	1.9
46.0	4.0	2.4	4.3	2.6	4.0	2.7	3.2	2.4	2.5	1.7
48.0	3.7	2.3	4.0	2.4	3.6	2.5	2.8	2.1	2.2	1.5
50.0	3.4	2.1	3.7	2.2	3.3	2.4	2.5	1.9	2.0	
54.0	2.9	1.8	3.2	1.9	2.7	2.1	2.0	1.5		
58.0	2.4	1.6	2.1	1.7		1.8				
62.0				1.5		1.6				
θ(°)	51~ 84.5	62~ 84.5	54~ 84.5	62~ 84.5	60~ 84.5	65~ 84.5	62~ 84.5	72~ 84.5	66~ 84.5	77~ 84.5
標準フック	12.2t									
フック重量	440kg									
標準巻掛本数	1									

カウンタウエイト 58t、アウトリガ張出幅 8.5m

ブーム+2.0m+3.5m油圧チルトジブ

単位:t

ブーム長さ(m) 作業半径 (m)	40.4			45.4			50.5			55.6			60.0		
	オフセット			オフセット			オフセット			オフセット			オフセット		
	0°	20°	40°	0°	20°	40°	0°	20°	40°	0°	20°	40°	0°	20°	40°
8.0	47.7														
9.0	44.9	42.5		38.0											
10.0	42.5	40.3	38.9	36.1	33.9			28.4							
11.0	40.3	38.4	37.1	34.4	32.4	31.1	27.0	25.5		23.9					
12.0	38.3	36.6	35.5	32.9	31.1	29.9	25.7	24.4	23.5	22.8	21.5				
14.0	35.0	33.6	32.7	30.3	28.8	27.8	23.6	22.5	21.7	20.8	19.9	19.2	19.7		
16.0	32.2	31.0	30.3	28.1	26.8	26.0	21.8	20.9	20.3	19.2	18.5	18.0	18.2	17.5	17.1
18.0	29.9	28.9	28.3	26.0	25.1	24.4	20.3	19.5	19.0	17.8	17.2	16.8	16.9	16.3	15.9
20.0	27.9	27.0	26.5	24.2	23.6	23.1	19.0	18.3	17.9	16.6	16.1	15.8	15.7	15.2	14.9
22.0	24.4	24.9	25.0	22.6	22.1	21.8	17.9	17.3	16.9	15.6	15.1	14.8	14.7	14.3	14.1
24.0	20.9	21.3	21.5	21.2	20.8	20.6	16.9	16.3	16.0	14.7	14.3	14.0	13.9	13.5	13.3
26.0	17.9	18.3	18.5	18.2	18.6	18.8	16.0	15.5	15.2	13.9	13.5	13.3	13.1	12.8	12.6
28.0	15.5	15.8	16.0	15.8	16.1	16.3	15.2	14.8	14.6	13.1	12.8	12.6	12.4	12.1	12.0
30.0	13.5	13.7	13.9	13.8	14.1	14.2	14.4	14.1	13.9	12.5	12.2	12.1	11.8	11.5	11.4
32.0	11.7	12.0	12.0	12.0	12.3	12.4	12.6	12.9	13.0	11.9	11.7	11.5	11.2	11.0	10.9
34.0	10.0	10.3	10.3	10.4	10.7	10.8	11.1	11.3	11.5	11.4	11.2	11.0	10.7	10.5	10.4
36.0	8.6	8.7		8.9	9.1	9.2	9.7	9.9	10.0	10.3	10.5	10.6	10.3	10.1	10.0
38.0	7.3	7.4		7.6	7.8	7.9	8.3	8.5	8.6	9.0	9.2	9.3	9.0	9.3	9.4
40.0	6.1	6.2		6.5	6.6		7.2	7.4	7.4	7.8	8.0	8.1	7.9	8.1	8.2
42.0	5.1			5.5	5.6		6.1	6.3	6.3	6.8	6.9	7.0	6.8	7.0	7.1
44.0	4.3			4.5	4.6		5.2	5.3		5.8	6.0	6.0	5.9	6.0	6.1
46.0				3.7	3.8		4.4	4.5		5.0	5.1	5.1	5.0	5.2	5.2
48.0				3.0			3.6	3.7		4.2	4.3		4.2	4.4	4.4
50.0							2.9	3.0		3.5	3.6		3.5	3.6	
54.0							1.8			2.3	2.3		2.3	2.4	
θ(°)	0~84.5	27~84.5	43~84.5	13~84.5	23~84.5	42~84.5	0~84.5	25~84.5	42~84.5	26~84.5	27~84.5	42~84.5	34~84.5	35~84.5	45~84.5
標準フック	80t						35t								
フック重量	1550kg						950kg								
標準巻掛本数	5						4						3		

カウンタウエイト 58t、アウトリガ張出幅 8.5m

ブーム+2.0m+11.5m油圧チルトジブ

単位:t

ブーム長さ(m) 作業半径 (m)	40.4			45.4			50.5			55.6			60.0		
	オフセット			オフセット			オフセット			オフセット			オフセット		
	0°	20°	40°	0°	20°	40°	0°	20°	40°	0°	20°	40°	0°	20°	40°
10.0	38.8														
11.0	36.7			31.1											
12.0	34.8			29.6			23.3								
14.0	31.5	27.6		27.0	23.4		21.2			18.8					
16.0	28.9	26.1	22.7	24.8	21.8		19.4	16.7		17.4	14.9		15.6		
18.0	26.6	24.2	21.8	23.0	20.4	18.8	18.0	15.8	14.0	16.0	14.0		15.1		
20.0	24.7	22.6	21.0	21.5	19.2	17.8	16.7	15.0	13.4	14.9	13.2	12.0	14.0	12.5	
22.0	23.0	21.3	20.1	20.1	18.1	16.9	15.6	14.1	12.8	13.9	12.5	11.4	13.1	11.9	
24.0	21.6	20.0	19.0	18.9	17.2	16.1	14.7	13.3	12.3	13.0	11.9	10.9	12.3	11.3	10.4
26.0	18.7	18.9	18.1	17.9	16.3	15.3	13.8	12.6	11.9	12.2	11.3	10.5	11.5	10.7	9.9
28.0	16.3	17.5	17.2	16.5	15.5	14.7	13.1	12.0	11.4	11.5	10.8	10.0	10.9	10.2	9.5
30.0	14.2	15.3	16.1	14.5	14.9	14.1	12.4	11.4	10.9	10.9	10.2	9.7	10.3	9.7	9.2
32.0	12.5	13.4	14.1	12.7	13.7	13.5	11.8	10.9	10.4	10.3	9.7	9.3	9.7	9.2	8.8
34.0	11.0	11.8	12.4	11.2	12.1	12.7	11.2	10.4	10.0	9.8	9.3	8.9	9.3	8.7	8.4
36.0	9.5	10.4	10.9	9.7	10.7	11.2	10.1	10.0	9.6	9.4	8.9	8.5	8.8	8.4	8.1
38.0	8.2	9.0	9.5	8.4	9.3	9.9	8.8	9.6	9.3	9.0	8.5	8.2	8.4	8.0	7.7
40.0	7.0	7.8	8.2	7.2	8.1	8.6	7.6	8.5	8.9	8.1	8.1	7.9	7.9	7.7	7.4
42.0	6.0	6.6	7.0	6.2	6.9	7.4	6.6	7.3	7.9	7.1	7.8	7.6	6.9	7.3	7.1
44.0	5.1	5.6		5.3	5.9	6.3	5.6	6.3	6.8	6.1	6.8	7.3	5.9	6.7	6.9
46.0	4.3	4.7		4.4	5.0	5.3	4.8	5.4	5.8	5.3	5.9	6.3	5.1	5.8	6.3
48.0	3.5	3.9		3.7	4.2		4.0	4.6	4.9	4.5	5.1	5.4	4.3	5.0	5.4
50.0	2.9			3.0	3.4		3.3	3.8	4.1	3.8	4.3	4.6	3.6	4.2	4.6
54.0				1.8	2.0		2.1	2.5		2.5	3.0	3.2	2.4	2.9	3.1
58.0										1.5	1.8			1.7	
θ(°)	17~83	28~84.5	44~84.5	20~83	24~84.5	44~84.5	31~83	35~84.5	43~84.5	32~83	36~84.5	43~84.5	43~83	41~84.5	48~84.5
標準フック	80t						35t								
フック重量	1550kg						950kg								
標準巻掛本数	4						3								

油圧チルトジブ

カウンタウエイト 58t、アウトリガ張出幅 8.5m

ブーム+2.0m+17.5m油圧チルトジブ

単位:t

ブーム長さ(m) 作業半径 (m)	40.4			45.4			50.5			55.6			60.0			
	オフセット			オフセット			オフセット			オフセット			オフセット			
	0°	20°	40°	0°	20°	40°	0°	20°	40°	0°	20°	40°	0°	20°	40°	
11.0	31.5															
12.0	30.3			27.0												
14.0	28.1			24.6			19.5									
16.0	26.3	20.6		22.6			17.9			15.6			14.8			
18.0	24.6	19.5		20.8	17.9		16.5	13.4		14.5			13.7			
20.0	22.8	18.6		19.4	16.8		15.3	12.7		13.5	11.3		12.8			
22.0	21.2	17.8	14.0	18.1	15.8		14.3	12.0		12.6	10.7		12.0	10.2		
24.0	19.9	17.1	13.6	17.0	15.0	13.7	13.4	11.5	10.1	11.9	10.1		11.2	9.6		
26.0	18.6	16.4	13.3	16.0	14.2	13.1	12.5	11.0	9.7	11.1	9.6	8.7	10.5	9.2	8.3	
28.0	16.9	15.8	12.9	15.1	13.5	12.5	11.8	10.5	9.3	10.5	9.2	8.3	9.9	8.7	7.9	
30.0	14.8	15.3	12.7	14.4	12.9	12.0	11.2	10.1	9.0	9.9	8.8	8.0	9.3	8.4	7.6	
32.0	13.0	14.5	12.4	13.0	12.3	11.5	10.6	9.6	8.7	9.3	8.4	7.7	8.8	8.0	7.3	
34.0	11.5	12.8	12.2	11.5	11.8	11.1	10.1	9.2	8.5	8.8	8.1	7.4	8.3	7.7	7.1	
36.0	10.1	11.3	12.0	10.1	11.3	10.6	9.6	8.8	8.2	8.4	7.7	7.1	7.9	7.4	6.8	
38.0	8.8	10.1	10.9	8.8	10.1	10.3	9.2	8.4	8.0	8.0	7.4	6.9	7.5	7.0	6.6	
40.0	7.6	8.8	9.6	7.6	8.9	9.7	8.0	8.1	7.7	7.6	7.1	6.7	7.2	6.7	6.4	
42.0	6.6	7.7	8.4	6.6	7.7	8.6	7.0	7.8	7.4	7.2	6.8	6.5	6.9	6.4	6.2	
44.0	5.6	6.6	7.2	5.6	6.7	7.4	6.0	7.1	7.1	6.2	6.5	6.3	6.0	6.2	6.0	
46.0	4.8	5.6	6.2	4.8	5.7	6.4	5.1	6.2	6.9	5.4	6.3	6.1	5.2	5.9	5.7	
48.0	4.0	4.8	5.2	4.0	4.9	5.4	4.4	5.3	5.9	4.6	5.6	5.9	4.4	5.4	5.5	
50.0	3.3	4.0		3.3	4.1	4.5	3.7	4.5	5.0	3.9	4.8	5.4	3.7	4.6	5.3	
54.0	2.1	2.5		2.1	2.7		2.4	3.1	3.5	2.6	3.4	3.8	2.4	3.2	3.8	
58.0					1.5			1.9		1.6	2.2	2.5		2.0	2.5	
θ(°)	23~	28~	44~	33~	30~	48~	40~	38~	47~	40~	44~	47~	48~	49~	52~	
	83	84.5	84.5	83	84.5	84.5	83	84.5	84.5	83	84.5	84.5	83	84.5	84.5	
標準フック	35t						35t									
フック重量	950kg						950kg									
標準巻掛本数	3						2									

カウンタウエイト 58t、アウトリガ張出幅 8.5m

ブーム+2.0m+23.5m油圧チルトジブ

単位:t

ブーム長さ(m) 作業半径 (m)	40.4			45.4			50.5			55.6			60.0			
	オフセット			オフセット			オフセット			オフセット			オフセット			
	0°	20°	40°	0°	20°	40°	0°	20°	40°	0°	20°	40°	0°	20°	40°	
12.0	25.7															
14.0	23.9			22.1			17.6									
16.0	22.2			20.7			16.2			14.2						
18.0	20.8			19.3			15.0			13.1			12.4			
20.0	19.6	14.4		17.9			14.0			12.2			11.6			
22.0	18.5	13.6		16.7	13.8		13.1	10.3		11.4			10.8			
24.0	17.5	12.9		15.6	13.2		12.2	9.8		10.6	8.8		10.1			
26.0	16.6	12.3	9.3	14.7	12.6		11.4	9.4		10.0	8.3		9.5	8.0		
28.0	15.8	11.7	9.0	13.8	12.1	9.1	10.7	9.0		9.4	7.9		9.0	7.6		
30.0	15.1	11.2	8.7	13.1	11.5	8.9	10.1	8.6	7.5	8.9	7.6	6.7	8.5	7.2		
32.0	13.5	10.7	8.5	12.4	11.0	8.6	9.6	8.2	7.2	8.5	7.2	6.5	8.0	6.9	6.2	
34.0	11.9	10.3	8.3	11.8	10.5	8.4	9.1	7.9	7.0	8.0	6.9	6.2	7.6	6.6	6.0	
36.0	10.6	9.9	8.1	10.5	10.0	8.2	8.6	7.6	6.8	7.6	6.6	6.0	7.2	6.3	5.7	
38.0	9.3	9.6	7.9	9.2	9.6	8.1	8.2	7.3	6.5	7.2	6.4	5.8	6.8	6.1	5.5	
40.0	8.1	9.2	7.7	8.0	9.2	7.9	7.8	7.1	6.3	6.9	6.1	5.6	6.5	5.8	5.3	
42.0	7.0	8.6	7.6	6.9	8.6	7.7	7.1	6.8	6.2	6.5	5.9	5.4	6.1	5.6	5.1	
44.0	6.1	7.5	7.5	6.0	7.5	7.6	6.2	6.5	6.0	6.2	5.7	5.2	5.8	5.4	4.9	
46.0	5.2	6.5	7.4	5.1	6.5	7.5	5.3	6.3	5.8	5.4	5.5	5.0	5.2	5.1	4.7	
48.0	4.4	5.6	6.4	4.3	5.6	6.5	4.5	5.8	5.7	4.7	5.3	4.9	4.4	4.8	4.5	
50.0	3.7	4.7	5.4	3.6	4.8	5.6	3.8	5.0	5.5	3.9	5.1	4.7	3.7	4.4	4.3	
54.0	2.5	3.3	3.7	2.4	3.3	3.9	2.5	3.6	4.3	2.7	3.7	4.4	2.4	3.6	3.9	
58.0		2.0			2.1	2.5	1.5	2.3	2.8	1.6	2.5	3.1		2.3	3.0	
62.0								1.6		1.5	1.9				1.9	
θ(°)	34~	33~	45~	41~	42~	45~	41~	47~	45~	45~	47~	51~	52~	55~	55~	
	83	84.5	84.5	83	84.5	84.5	83	84.5	84.5	83	84.5	84.5	83	84.5	84.5	
標準フック	35t						35t									
フック重量	950kg						950kg									
標準巻掛本数	3						2									

カウンタウエイト 58t、アウトリガ張出幅 8.5m

ブーム+2.0m+29.5m油圧チルトジブ

単位:t

ブーム長さ(m) 作業半径 (m)	40.4			45.4			50.5			55.6			60.0			
	オフセット			オフセット			オフセット			オフセット			オフセット			
	0°	20°	40°	0°	20°	40°	0°	20°	40°	0°	20°	40°	0°	20°	40°	
14.0	20.4			18.9												
16.0	19.0			17.7			14.7									
18.0	17.8			16.7			13.6					12.4				
20.0	16.7			15.7			12.6				11.4			10.9		
22.0	15.8			14.9			11.7				10.6			10.1		
24.0	14.9	10.2		14.1	10.5		11.0				9.9			9.5		
26.0	14.1	9.6		13.4	9.9		10.3	8.2			9.3			8.9		
28.0	13.4	9.1		12.7	9.4		9.8	7.8			8.7	7.2		8.3		
30.0	12.8	8.7		11.9	9.0		9.2	7.4			8.2	6.8		7.9	6.5	
32.0	12.2	8.3	6.2	11.3	8.6	6.3	8.7	7.1			7.8	6.5		7.4	6.2	
34.0	11.4	7.9	6.0	10.7	8.2	6.1	8.2	6.8	5.9		7.4	6.2		7.0	5.9	
36.0	10.7	7.6	5.9	10.2	7.9	6.0	7.8	6.5	5.7	7.0	5.9	5.3		6.7	5.5	
38.0	9.5	7.2	5.7	9.3	7.5	5.8	7.4	6.3	5.5	6.7	5.7	5.1		6.3	5.2	4.4
40.0	8.3	6.9	5.5	8.2	7.2	5.6	7.0	6.0	5.3	6.4	5.4	4.9		5.9	4.9	4.2
42.0	7.2	6.7	5.4	7.1	7.0	5.5	6.7	5.8	5.1	6.0	5.2	4.7		5.4	4.6	4.0
44.0	6.3	6.4	5.3	6.1	6.7	5.4	6.2	5.6	5.0	5.7	5.0	4.5		5.0	4.3	3.8
46.0	5.4	6.2	5.1	5.2	6.5	5.2	5.3	5.4	4.8	5.4	4.8	4.3		4.6	4.1	3.6
48.0	4.6	6.0	5.0	4.5	6.1	5.1	4.5	5.2	4.7	4.9	4.6	4.2		4.2	3.9	3.4
50.0	3.9	5.3	5.0	3.7	5.2	5.0	3.8	5.1	4.6	4.1	4.4	4.1		3.9	3.6	3.3
54.0	2.6	3.8	4.7	2.5	3.8	4.7	2.6	3.9	4.3	2.9	3.9	3.8		2.6	3.2	3.0
58.0	1.6	2.5	3.1		2.5	3.3	1.5	2.6	3.5	1.8	3.0	3.3			2.7	2.7
62.0						1.9		1.6	2.2		1.9	2.6				2.4
θ(°)	36~ 83	44~ 84.5	49~ 84.5	46~ 83	50~ 84.5	49~ 84.5	46~ 83	49~ 84.5	54~ 84.5	50~ 83	54~ 84.5	59~ 84.5	56~ 83	60~ 84.5	61~ 84.5	
標準フック	35t												12.2t			
フック重量	950kg												440kg			
標準巻掛本数	2												1			

カウンタウエイト 58t、アウトリガ張出幅 8.5m

ブーム+2.0m+35.5m油圧チルトジブ

単位:t

ブーム長さ(m) 作業半径 (m)	40.4			45.4			50.5			55.6			60.0			
	オフセット			オフセット			オフセット			オフセット			オフセット			
	0°	20°	40°	0°	20°	40°	0°	20°	40°	0°	20°	40°	0°	20°	40°	
14.0	17.2															
16.0	16.2			15.1												
18.0	15.3			14.3			12.9									
20.0	14.5			13.6			12.0				10.6					
22.0	13.7			12.9			11.1				9.8			9.4		
24.0	12.8			12.3			10.4				9.2			8.7		
26.0	12.0	7.9		11.7			9.8				8.6			8.2		
28.0	11.3	7.5		11.1	7.7		9.2				8.0			7.7		
30.0	10.7	7.1		10.6	7.3		8.7	6.8			7.5			7.2		
32.0	10.1	6.7		10.1	6.9		8.2	6.5			7.1	5.8		6.8	5.4	
34.0	9.6	6.4		9.7	6.6		7.8	6.2			6.7	5.6		6.4	5.0	
36.0	8.9	6.1	4.5	9.2	6.3		7.4	5.9			6.4	5.3		6.1	4.7	
38.0	8.4	5.8	4.3	8.8	6.0	4.4	7.0	5.7			6.0	5.0		5.8	4.4	
40.0	7.9	5.5	4.2	8.4	5.7	4.2	6.7	5.5	4.5		5.7	4.8		5.3	4.1	
42.0	7.4	5.3	4.0	7.3	5.5	4.1	6.3	5.2	4.4	5.5	4.6	4.1		4.9	3.9	3.3
44.0	6.6	5.0	3.9	6.4	5.3	4.0	6.0	5.0	4.3	5.2	4.4	3.9		4.5	3.6	3.1
46.0	5.7	4.8	3.8	5.5	5.0	3.9	5.7	4.8	4.1	4.8	4.2	3.7		4.1	3.4	2.9
48.0	4.9	4.6	3.7	4.7	4.8	3.7	5.0	4.7	4.0	4.5	4.0	3.5		3.7	3.2	2.7
50.0	4.2	4.4	3.6	4.0	4.7	3.7	4.3	4.5	3.9	4.1	3.8	3.3		3.4	3.0	2.6
54.0	2.9	4.1	3.4	2.7	4.3	3.5	3.0	4.1	3.7	3.0	3.4	3.0		2.7	2.6	2.3
58.0	1.8	3.1	3.3	1.6	3.0	3.3	1.9	3.3	3.4		2.9	2.7			2.3	2.0
62.0		2.0	2.7		1.9	2.8		2.2	3.0		2.3	2.4				1.8
66.0			1.5			1.6			2.0			2.1				
θ(°)	42~ 83	47~ 84.5	46~ 84.5	47~ 83	52~ 84.5	53~ 84.5	51~ 83	56~ 84.5	58~ 84.5	57~ 83	59~ 84.5	61~ 84.5	59~ 83	64~ 84.5	67~ 84.5	
標準フック	35t												12.2t			
フック重量	950kg												440kg			
標準巻掛本数	2												1			

油圧チルトジブ

カウンタウエイト 58t、アウトリガ張出幅 8.5m

ブーム+2.0m+41.5m油圧チルトジブ

単位:t

ブーム長さ(m) 作業半径 (m)	40.4			45.4			50.5			55.6			60.0		
	オフセット			オフセット			オフセット			オフセット			オフセット		
	0°	20°	40°	0°	20°	40°	0°	20°	40°	0°	20°	40°	0°	20°	40°
16.0	13.4			12.3											
18.0	12.7			11.7			10.5								
20.0	12.0			11.1			10.0					8.9			
22.0	11.3			10.5			9.6				8.6				
24.0	10.6			10.0			9.2				8.2			7.7	
26.0	10.0			9.5			8.8				7.7			7.3	
28.0	9.3			9.1			8.2				7.2			6.8	
30.0	8.8	5.8		8.7			7.7				6.7			6.4	
32.0	8.3	5.4		8.3	5.6		7.3				6.3			6.0	
34.0	7.8	5.1		7.9	5.3		6.9	5.4			5.9			5.6	
36.0	7.4	4.8		7.5	5.0		6.5	5.1			5.6	4.6		5.1	3.7
38.0	7.0	4.5		7.1	4.7		6.1	4.9			5.3	4.3		4.7	3.4
40.0	6.5	4.2		6.7	4.4		5.8	4.6			5.0	4.0		4.3	3.1
42.0	6.1	4.0	2.8	6.4	4.2		5.5	4.4			4.6	3.7		3.9	2.9
44.0	5.7	3.8	2.6	6.1	4.0	2.7	5.1	4.1			4.2	3.4		3.6	2.7
46.0	5.3	3.6	2.5	5.6	3.8	2.6	4.8	3.9	2.6		3.8	3.2		3.3	2.5
48.0	4.9	3.4	2.4	4.8	3.6	2.5	4.4	3.7	2.5	3.5	3.0	2.5		2.9	2.3
50.0	4.2	3.2	2.3	4.0	3.4	2.4	4.0	3.5	2.4	3.2	2.7	2.3		2.6	2.1
54.0	3.0	2.9	2.1	2.7	3.1	2.2	2.7	3.1	2.3	2.6	2.4	2.0		1.7	
58.0	1.9	2.6	2.0		2.8	2.0		2.7	2.1		2.0	1.7			
62.0		2.3	1.8		2.2	1.9			2.0						
66.0			1.7			1.8									
θ(°)	47~ 83	54~ 84.5	56~ 84.5	54~ 83	57~ 84.5	61~ 84.5	57~ 83	64~ 84.5	68~ 84.5	60~ 83	66~ 84.5	73~ 84.5	64~ 83	70~ 84.5	80~ 84.5
標準フック	35t						12.2t								
フック重量	950kg						440kg								
標準巻掛本数	2						1								

カウンタウエイト 58t、アウトリガ張出幅 8.5m

ブーム+2.0m+47.5m油圧チルトジブ

単位:t

ブーム長さ(m) 作業半径 (m)	40.4		45.4		50.5		55.6		60.0	
	オフセット		オフセット		オフセット		オフセット		オフセット	
	0°	20°	0°	20°	0°	20°	0°	20°	0°	20°
16.0	10.7									
18.0	10.1		9.3							
20.0	9.6		8.8		7.8					
22.0	9.0		8.3		7.5		6.5			
24.0	8.5		7.9		7.1		6.3			
26.0	8.1		7.5		6.8		6.0		5.6	
28.0	7.6		7.1		6.5		5.8		5.4	
30.0	7.2		6.8		6.2		5.6		5.2	
32.0	6.7		6.5		5.9		5.3		4.9	
34.0	6.3	3.7	6.2		5.6		5.1		4.7	
36.0	5.9	3.5	5.9	3.6	5.4		4.9		4.2	
38.0	5.4	3.2	5.6	3.4	5.2	3.5	4.6		3.8	
40.0	5.0	3.0	5.3	3.1	4.9	3.3	4.2	3.1	3.5	
42.0	4.6	2.8	5.0	2.9	4.7	3.1	3.8	2.8	3.1	2.1
44.0	4.3	2.6	4.7	2.7	4.4	2.9	3.5	2.6	2.8	1.9
46.0	4.0	2.4	4.3	2.6	4.0	2.7	3.2	2.4	2.5	1.7
48.0	3.7	2.3	4.0	2.4	3.6	2.5	2.8	2.1	2.2	1.5
50.0	3.4	2.1	3.7	2.2	3.3	2.4	2.5	1.9		
54.0	2.9	1.8	2.7	1.9		2.1		1.5		
58.0	1.8	1.6		1.7		1.8				
62.0				1.5						
θ(°)	51~ 84.5	62~ 84.5	57~ 84.5	62~ 84.5	62~ 84.5	68~ 84.5	65~ 84.5	72~ 84.5	68~ 84.5	77~ 84.5
標準フック	12.2t									
フック重量	440kg									
標準巻掛本数	1									

カウンタウエイト 58t、アウトリガ張出幅 8.0m
 ブーム+2.0m+3.5m油圧チルトジブ

単位:t

ブーム長さ(m) 作業半径 (m)	40.4			45.4			50.5			55.6			60.0		
	オフセット			オフセット			オフセット			オフセット			オフセット		
	0°	20°	40°	0°	20°	40°	0°	20°	40°	0°	20°	40°	0°	20°	40°
8.0	47.7														
9.0	44.9	42.5		38.0											
10.0	42.5	40.3	38.9	36.1	33.9			28.4							
11.0	40.3	38.4	37.1	34.4	32.4	31.1	27.0	25.5		23.9					
12.0	38.3	36.6	35.5	32.9	31.1	29.9	25.7	24.4	23.5	22.8	21.5				
14.0	35.0	33.6	32.7	30.3	28.8	27.8	23.6	22.5	21.7	20.8	19.9	19.2	19.7		
16.0	32.2	31.0	30.3	28.1	26.8	26.0	21.8	20.9	20.3	19.2	18.5	18.0	18.2	17.5	17.1
18.0	29.9	28.9	28.3	26.0	25.1	24.4	20.3	19.5	19.0	17.8	17.2	16.8	16.9	16.3	15.9
20.0	26.9	27.0	26.5	24.2	23.6	23.1	19.0	18.3	17.9	16.6	16.1	15.8	15.7	15.2	14.9
22.0	22.7	23.1	23.4	22.6	22.1	21.8	17.9	17.3	16.9	15.6	15.1	14.8	14.7	14.3	14.1
24.0	19.3	19.7	20.0	19.6	20.0	20.3	16.9	16.3	16.0	14.7	14.3	14.0	13.9	13.5	13.3
26.0	16.6	16.9	17.1	16.9	17.2	17.5	16.0	15.5	15.2	13.9	13.5	13.3	13.1	12.8	12.6
28.0	14.3	14.6	14.7	14.6	14.9	15.1	15.2	14.8	14.6	13.1	12.8	12.6	12.4	12.1	12.0
30.0	12.4	12.6	12.7	12.7	12.9	13.1	13.3	13.5	13.7	12.5	12.2	12.1	11.8	11.5	11.4
32.0	10.6	10.8	10.9	10.9	11.2	11.4	11.6	11.9	12.0	11.9	11.7	11.5	11.2	11.0	10.9
34.0	9.0	9.2	9.2	9.3	9.6	9.7	10.1	10.3	10.5	10.7	10.9	11.0	10.7	10.5	10.4
36.0	7.6	7.7		7.9	8.2	8.2	8.7	8.9	9.0	9.3	9.6	9.7	9.4	9.6	9.8
38.0	6.3	6.5		6.7	6.9	6.9	7.4	7.6	7.7	8.0	8.3	8.4	8.1	8.4	8.5
40.0	5.3	5.4		5.6	5.8		6.3	6.5	6.5	6.9	7.1	7.2	7.0	7.2	7.3
42.0	4.3			4.6	4.8		5.3	5.5	5.5	5.9	6.1	6.2	6.0	6.2	6.3
44.0	3.6			3.8	3.9		4.4	4.6		5.0	5.2	5.2	5.1	5.3	5.3
46.0				3.0	3.1		3.6	3.7		4.2	4.4	4.4	4.3	4.4	4.5
48.0							2.9	3.0		3.5	3.6		3.5	3.7	3.7
50.0							2.3	2.3		2.8	2.9		2.9	3.0	
54.0										1.7	1.7		1.7	1.8	
θ(°)	0~ 84.5	27~ 84.5	43~ 84.5	22~ 84.5	23~ 84.5	42~ 84.5	24~ 84.5	25~ 84.5	42~ 84.5	26~ 84.5	27~ 84.5	42~ 84.5	34~ 84.5	35~ 84.5	45~ 84.5
標準フック	80t						35t								
フック重量	1550kg						950kg								
標準巻掛本数	5						4						3		

カウンタウエイト 58t、アウトリガ張出幅 8.0m
 ブーム+2.0m+11.5m油圧チルトジブ

単位:t

ブーム長さ(m) 作業半径 (m)	40.4			45.4			50.5			55.6			60.0		
	オフセット			オフセット			オフセット			オフセット			オフセット		
	0°	20°	40°	0°	20°	40°	0°	20°	40°	0°	20°	40°	0°	20°	40°
10.0	38.8														
11.0	36.7			31.1											
12.0	34.8			29.6			23.3								
14.0	31.5	27.6		27.0	23.4		21.2			18.8					
16.0	28.9	26.1	22.7	24.8	21.8		19.4	16.7		17.4	14.9		15.6		
18.0	26.6	24.2	21.8	23.0	20.4	18.8	18.0	15.8	14.0	16.0	14.0		15.1		
20.0	24.7	22.6	21.0	21.5	19.2	17.8	16.7	15.0	13.4	14.9	13.2	12.0	14.0	12.5	
22.0	23.0	21.3	20.1	20.1	18.1	16.9	15.6	14.1	12.8	13.9	12.5	11.4	13.1	11.9	
24.0	20.1	20.0	19.0	18.9	17.2	16.1	14.7	13.3	12.3	13.0	11.9	10.9	12.3	11.3	10.4
26.0	17.3	18.6	18.1	17.6	16.3	15.3	13.8	12.6	11.9	12.2	11.3	10.5	11.5	10.7	9.9
28.0	15.0	16.2	17.1	15.3	15.5	14.7	13.1	12.0	11.4	11.5	10.8	10.0	10.9	10.2	9.5
30.0	13.1	14.2	14.9	13.3	14.4	14.1	12.4	11.4	10.9	10.9	10.2	9.7	10.3	9.7	9.2
32.0	11.5	12.4	13.1	11.7	12.6	13.4	11.8	10.9	10.4	10.3	9.7	9.3	9.7	9.2	8.8
34.0	9.9	10.9	11.4	10.1	11.1	11.7	10.5	10.4	10.0	9.8	9.3	8.9	9.3	8.7	8.4
36.0	8.5	9.4	10.0	8.7	9.7	10.3	9.1	10.0	9.6	9.4	8.9	8.5	8.8	8.4	8.1
38.0	7.3	8.1	8.6	7.5	8.4	9.0	7.9	8.8	9.3	8.3	8.5	8.2	8.2	8.0	7.7
40.0	6.2	6.9	7.3	6.4	7.2	7.7	6.7	7.6	8.2	7.2	8.1	7.9	7.1	7.7	7.4
42.0	5.2	5.8	6.1	5.4	6.1	6.5	5.8	6.5	7.0	6.2	7.0	7.5	6.1	6.9	7.1
44.0	4.3	4.8		4.5	5.1	5.5	4.9	5.6	6.0	5.3	6.0	6.5	5.2	5.9	6.4
46.0	3.5	4.0		3.7	4.3	4.5	4.1	4.7	5.0	4.5	5.2	5.6	4.3	5.0	5.5
48.0	2.8	3.2		3.0	3.5		3.3	3.9	4.2	3.8	4.4	4.7	3.6	4.2	4.7
50.0				2.3	2.7		2.7	3.2	3.4	3.1	3.6	3.9	2.9	3.5	3.9
54.0							1.5	1.9		1.9	2.4	2.6	1.8	2.2	2.5
θ(°)	24~ 83	28~ 84.5	44~ 84.5	30~ 83	34~ 84.5	44~ 84.5	31~ 83	35~ 84.5	43~ 84.5	38~ 83	42~ 84.5	43~ 84.5	43~ 83	46~ 84.5	48~ 84.5
標準フック	80t						35t								
フック重量	1550kg						950kg								
標準巻掛本数	4						3								

油圧チルトジブ

カウンタウエイト 58t、アウトリガ張出幅 8.0m

ブーム+2.0m+17.5m油圧チルトジブ

単位:t

ブーム長さ(m) 作業半径 (m)	40.4			45.4			50.5			55.6			60.0		
	オフセット			オフセット			オフセット			オフセット			オフセット		
	0°	20°	40°	0°	20°	40°	0°	20°	40°	0°	20°	40°	0°	20°	40°
11.0	31.5														
12.0	30.3			27.0											
14.0	28.1			24.6			19.5								
16.0	26.3	20.6		22.6			17.9			15.6			14.8		
18.0	24.6	19.5		20.8	17.9		16.5	13.4		14.5			13.7		
20.0	22.8	18.6		19.4	16.8		15.3	12.7		13.5	11.3		12.8		
22.0	21.2	17.8	14.0	18.1	15.8		14.3	12.0		12.6	10.7		12.0	10.2	
24.0	19.9	17.1	13.6	17.0	15.0	13.7	13.4	11.5	10.1	11.9	10.1		11.2	9.6	
26.0	17.9	16.4	13.3	16.0	14.2	13.1	12.5	11.0	9.7	11.1	9.6	8.7	10.5	9.2	8.3
28.0	15.6	15.8	12.9	15.1	13.5	12.5	11.8	10.5	9.3	10.5	9.2	8.3	9.9	8.7	7.9
30.0	13.7	15.2	12.7	13.7	12.9	12.0	11.2	10.1	9.0	9.9	8.8	8.0	9.3	8.4	7.6
32.0	12.0	13.4	12.4	12.0	12.3	11.5	10.6	9.6	8.7	9.3	8.4	7.7	8.8	8.0	7.3
34.0	10.5	11.8	12.2	10.5	11.8	11.1	10.1	9.2	8.5	8.8	8.1	7.4	8.3	7.7	7.1
36.0	9.1	10.4	11.3	9.1	10.5	10.6	9.5	8.8	8.2	8.4	7.7	7.1	7.9	7.4	6.8
38.0	7.8	9.2	10.0	7.8	9.2	10.1	8.3	8.4	8.0	8.0	7.4	6.9	7.5	7.0	6.6
40.0	6.7	7.9	8.8	6.7	8.0	8.9	7.1	8.1	7.7	7.4	7.1	6.7	7.1	6.7	6.4
42.0	5.7	6.8	7.6	5.7	6.9	7.7	6.1	7.3	7.4	6.3	6.8	6.5	6.1	6.4	6.2
44.0	4.8	5.8	6.4	4.8	5.9	6.6	5.2	6.3	7.1	5.4	6.5	6.3	5.2	6.2	6.0
46.0	4.0	4.9	5.4	4.0	5.0	5.6	4.4	5.4	6.1	4.6	5.7	6.1	4.4	5.5	5.7
48.0	3.3	4.1	4.4	3.3	4.1	4.7	3.7	4.6	5.2	3.9	4.8	5.5	3.7	4.7	5.4
50.0	2.7	3.3		2.6	3.4	3.8	3.0	3.8	4.4	3.2	4.1	4.7	3.0	3.9	4.6
54.0	1.5	1.9		1.5	2.1		1.8	2.5	2.9	2.0	2.8	3.2	1.8	2.6	3.1
58.0											1.6	2.0		1.5	1.9
θ(°)	23~ 83	28~ 84.5	44~ 84.5	33~ 83	38~ 84.5	48~ 84.5	40~ 83	44~ 84.5	47~ 84.5	45~ 83	44~ 84.5	47~ 84.5	48~ 83	49~ 84.5	52~ 84.5
標準フック	35t						35t								
フック重量	950kg						950kg								
標準巻掛本数	3						2								

カウンタウエイト 58t、アウトリガ張出幅 8.0m

ブーム+2.0m+23.5m油圧チルトジブ

単位:t

ブーム長さ(m) 作業半径 (m)	40.4			45.4			50.5			55.6			60.0		
	オフセット			オフセット			オフセット			オフセット			オフセット		
	0°	20°	40°	0°	20°	40°	0°	20°	40°	0°	20°	40°	0°	20°	40°
12.0	25.7														
14.0	23.9			22.1			17.6								
16.0	22.2			20.7			16.2			14.2					
18.0	20.8			19.3			15.0			13.1			12.4		
20.0	19.6	14.4		17.9			14.0			12.2			11.6		
22.0	18.5	13.6		16.7	13.8		13.1	10.3		11.4			10.8		
24.0	17.5	12.9		15.6	13.2		12.2	9.8		10.6	8.8		10.1		
26.0	16.6	12.3	9.3	14.7	12.6		11.4	9.4		10.0	8.3		9.5	8.0	
28.0	15.8	11.7	9.0	13.8	12.1	9.1	10.7	9.0		9.4	7.9		9.0	7.6	
30.0	14.1	11.2	8.7	13.1	11.5	8.9	10.1	8.6	7.5	8.9	7.6	6.7	8.5	7.2	
32.0	12.4	10.7	8.5	12.4	11.0	8.6	9.6	8.2	7.2	8.5	7.2	6.5	8.0	6.9	6.2
34.0	11.0	10.3	8.3	10.9	10.5	8.4	9.1	7.9	7.0	8.0	6.9	6.2	7.6	6.6	6.0
36.0	9.6	9.9	8.1	9.5	10.0	8.2	8.6	7.6	6.8	7.6	6.6	6.0	7.2	6.3	5.7
38.0	8.3	9.6	7.9	8.2	9.6	8.1	8.2	7.3	6.5	7.2	6.4	5.8	6.8	6.1	5.5
40.0	7.2	8.9	7.7	7.1	8.9	7.9	7.3	7.1	6.3	6.9	6.1	5.6	6.5	5.8	5.3
42.0	6.2	7.7	7.6	6.1	7.7	7.7	6.3	6.8	6.2	6.4	5.9	5.4	6.1	5.6	5.1
44.0	5.3	6.7	7.5	5.2	6.7	7.6	5.4	6.5	6.0	5.5	5.7	5.2	5.3	5.4	4.9
46.0	4.5	5.7	6.7	4.4	5.7	6.8	4.5	5.9	5.8	4.7	5.5	5.0	4.4	5.1	4.7
48.0	3.7	4.8	5.7	3.6	4.9	5.8	3.8	5.1	5.7	3.9	5.3	4.9	3.7	4.8	4.5
50.0	3.0	4.1	4.7	3.0	4.1	4.9	3.1	4.3	5.2	3.3	4.5	4.7	3.0	4.3	4.3
54.0	1.9	2.7	3.1	1.8	2.7	3.3	1.9	2.9	3.6	2.1	3.1	3.9		2.9	3.8
58.0					1.5	1.9		1.8	2.3		1.9	2.6			2.5
θ(°)	34~ 83	41~ 84.5	45~ 84.5	41~ 83	42~ 84.5	45~ 84.5	45~ 83	47~ 84.5	51~ 84.5	50~ 83	52~ 84.5	56~ 84.5	56~ 83	59~ 84.5	59~ 84.5
標準フック	35t						35t								
フック重量	950kg						950kg								
標準巻掛本数	3						2								

カウンタウエイト 58t、アウトリガ張出幅 8.0m

ブーム+2.0m+29.5m油圧チルトジブ

単位:t

ブーム長さ(m) 作業半径 (m)	40.4			45.4			50.5			55.6			60.0		
	オフセット			オフセット			オフセット			オフセット			オフセット		
	0°	20°	40°	0°	20°	40°	0°	20°	40°	0°	20°	40°	0°	20°	40°
14.0	20.4			18.9											
16.0	19.0			17.7			14.7								
18.0	17.8			16.7			13.6					12.4			
20.0	16.7			15.7			12.6				11.4			10.9	
22.0	15.8			14.9			11.7				10.6			10.1	
24.0	14.9	10.2		14.1	10.5		11.0				9.9			9.5	
26.0	14.1	9.6		13.4	9.9		10.3	8.2			9.3			8.9	
28.0	13.4	9.1		12.7	9.4		9.8	7.8			8.7	7.2		8.3	
30.0	12.8	8.7		11.9	9.0		9.2	7.4			8.2	6.8		7.9	6.5
32.0	12.2	8.3	6.2	11.3	8.6	6.3	8.7	7.1			7.8	6.5		7.4	6.2
34.0	11.1	7.9	6.0	10.7	8.2	6.1	8.2	6.8	5.9		7.4	6.2		7.0	5.9
36.0	9.8	7.6	5.9	9.7	7.9	6.0	7.8	6.5	5.7	7.0	5.9	5.3		6.7	5.5
38.0	8.5	7.2	5.7	8.4	7.5	5.8	7.4	6.3	5.5	6.7	5.7	5.1		6.3	5.2
40.0	7.4	6.9	5.5	7.2	7.2	5.6	7.0	6.0	5.3	6.4	5.4	4.9		5.9	4.9
42.0	6.4	6.7	5.4	6.2	7.0	5.5	6.3	5.8	5.1	6.0	5.2	4.7		5.4	4.6
44.0	5.5	6.4	5.3	5.3	6.7	5.4	5.4	5.6	5.0	5.7	5.0	4.5		5.0	4.3
46.0	4.6	6.2	5.1	4.5	6.2	5.2	4.6	5.4	4.8	4.9	4.8	4.3		4.6	4.1
48.0	3.9	5.4	5.0	3.7	5.4	5.1	3.8	5.2	4.7	4.2	4.6	4.2		3.9	3.4
50.0	3.2	4.6	5.0	3.1	4.5	5.0	3.1	4.7	4.6	3.5	4.4	4.1		3.2	3.6
54.0	2.0	3.2	4.0	1.9	3.1	4.1	1.9	3.3	4.3	2.2	3.6	3.8		3.2	3.0
58.0		1.9	2.5		1.9	2.7		2.1	2.9		2.4	3.3			2.7
62.0									1.7						2.1
θ(°)	41~83	44~84.5	49~84.5	46~83	50~84.5	55~84.5	50~83	54~84.5	54~84.5	54~83	57~84.5	59~84.5	59~83	63~84.5	65~84.5
標準フック	35t												12.2t		
フック重量	950kg												440kg		
標準巻掛本数	2												1		

カウンタウエイト 58t、アウトリガ張出幅 8.0m

ブーム+2.0m+35.5m油圧チルトジブ

単位:t

ブーム長さ(m) 作業半径 (m)	40.4			45.4			50.5			55.6			60.0		
	オフセット			オフセット			オフセット			オフセット			オフセット		
	0°	20°	40°	0°	20°	40°	0°	20°	40°	0°	20°	40°	0°	20°	40°
14.0	17.2														
16.0	16.2			15.1											
18.0	15.3			14.3			12.9								
20.0	14.5			13.6			12.0				10.6				
22.0	13.7			12.9			11.1				9.8			9.4	
24.0	12.8			12.3			10.4				9.2			8.7	
26.0	12.0	7.9		11.7			9.8				8.6			8.2	
28.0	11.3	7.5		11.1	7.7		9.2				8.0			7.7	
30.0	10.7	7.1		10.6	7.3		8.7	6.8			7.5			7.2	
32.0	10.1	6.7		10.1	6.9		8.2	6.5			7.1	5.8		6.8	5.4
34.0	9.6	6.4		9.7	6.6		7.8	6.2			6.7	5.6		6.4	5.0
36.0	8.9	6.1	4.5	9.2	6.3		7.4	5.9			6.4	5.3		6.1	4.7
38.0	8.4	5.8	4.3	8.7	6.0	4.4	7.0	5.7			6.0	5.0		5.8	4.4
40.0	7.7	5.5	4.2	7.5	5.7	4.2	6.7	5.5	4.5		5.7	4.8		5.3	4.1
42.0	6.7	5.3	4.0	6.5	5.5	4.1	6.3	5.2	4.4	5.5	4.6	4.1		4.9	3.9
44.0	5.8	5.0	3.9	5.6	5.3	4.0	5.9	5.0	4.3	5.2	4.4	3.9		4.5	3.6
46.0	4.9	4.8	3.8	4.7	5.0	3.9	5.0	4.8	4.1	4.8	4.2	3.7		4.1	3.4
48.0	4.2	4.6	3.7	4.0	4.8	3.7	4.3	4.7	4.0	4.3	4.0	3.5		3.7	2.9
50.0	3.5	4.4	3.6	3.3	4.7	3.7	3.6	4.5	3.9	3.6	3.8	3.3		3.3	2.6
54.0	2.3	3.8	3.4	2.1	3.7	3.5	2.3	4.0	3.7	2.4	3.4	3.0		2.6	2.3
58.0		2.5	3.3		2.4	3.3		2.7	3.4		2.8	2.7		2.3	2.0
62.0			2.2			2.3			2.7			2.4			1.8
θ(°)	47~83	52~84.5	53~84.5	50~83	56~84.5	58~84.5	54~83	59~84.5	62~84.5	57~83	62~84.5	65~84.5	62~83	64~84.5	67~84.5
標準フック	35t												12.2t		
フック重量	950kg												440kg		
標準巻掛本数	2												1		

油圧チルトジブ

カウンタウエイト 58t、アウトリガ張出幅 8.0m

ブーム+2.0m+41.5m油圧チルトジブ

単位:t

ブーム長さ(m) 作業半径 (m)	40.4			45.4			50.5			55.6			60.0		
	オフセット			オフセット			オフセット			オフセット			オフセット		
	0°	20°	40°	0°	20°	40°	0°	20°	40°	0°	20°	40°	0°	20°	40°
16.0	13.4			12.3											
18.0	12.7			11.7			10.5								
20.0	12.0			11.1			10.0			8.9					
22.0	11.3			10.5			9.6			8.6					
24.0	10.6			10.0			9.2			8.2			7.7		
26.0	10.0			9.5			8.8			7.7			7.3		
28.0	9.3			9.1			8.2			7.2			6.8		
30.0	8.8	5.8		8.7			7.7			6.7			6.4		
32.0	8.3	5.4		8.3	5.6		7.3			6.3			6.0		
34.0	7.8	5.1		7.9	5.3		6.9	5.4		5.9			5.6		
36.0	7.4	4.8		7.5	5.0		6.5	5.1		5.6	4.6		5.1	3.7	
38.0	7.0	4.5		7.1	4.7		6.1	4.9		5.3	4.3		4.7	3.4	
40.0	6.5	4.2		6.7	4.4		5.8	4.6		5.0	4.0		4.3	3.1	
42.0	6.1	4.0	2.8	6.4	4.2		5.5	4.4		4.6	3.7		3.9	2.9	
44.0	5.7	3.8	2.6	5.6	4.0	2.7	5.1	4.1		4.2	3.4		3.6	2.7	
46.0	5.0	3.6	2.5	4.8	3.8	2.6	4.8	3.9	2.6	3.8	3.2		3.3	2.5	
48.0	4.3	3.4	2.4	4.0	3.6	2.5	4.0	3.7	2.5	3.5	3.0	2.5	2.9	2.3	1.9
50.0	3.6	3.2	2.3	3.3	3.4	2.4	3.3	3.5	2.4	3.2	2.7	2.3		2.1	1.7
54.0	2.3	2.9	2.1	2.1	3.1	2.2		3.1	2.3		2.4	2.0			
58.0		2.6	2.0		2.7	2.0		2.7	2.1			1.7			
62.0		1.7	1.8			1.9			2.0						
θ(°)	51~ 83	54~ 84.5	61~ 84.5	54~ 83	61~ 84.5	65~ 84.5	60~ 83	64~ 84.5	68~ 84.5	62~ 83	69~ 84.5	73~ 84.5	66~ 83	70~ 84.5	80~ 84.5
標準フック	35t						12.2t								
フック重量	950kg						440kg								
標準巻掛本数	2						1								

カウンタウエイト 58t、アウトリガ張出幅 6.8m

ブーム+2.0m+3.5m油圧チルトジブ

単位:t

ブーム長さ(m) 作業半径 (m)	40.4			45.4			50.5			55.6			60.0		
	オフセット			オフセット			オフセット			オフセット			オフセット		
	0°	20°	40°	0°	20°	40°	0°	20°	40°	0°	20°	40°	0°	20°	40°
8.0	47.7														
9.0	44.9	42.5		38.0											
10.0	42.5	40.3	38.9	36.1	33.9			28.4							
11.0	40.3	38.4	37.1	34.4	32.4	31.1	27.0	25.5		23.9					
12.0	38.3	36.6	35.5	32.9	31.1	29.9	25.7	24.4	23.5	22.8	21.5				
14.0	35.0	33.6	32.7	30.3	28.8	27.8	23.6	22.5	21.7	20.8	19.9	19.2	19.7		
16.0	32.2	31.0	30.3	28.1	26.8	26.0	21.8	20.9	20.3	19.2	18.5	18.0	18.2	17.5	17.1
18.0	26.7	27.3	27.8	26.0	25.1	24.4	20.3	19.5	19.0	17.8	17.2	16.8	16.9	16.3	15.9
20.0	22.2	22.7	23.1	22.5	23.0	23.1	19.0	18.3	17.9	16.6	16.1	15.8	15.7	15.2	14.9
22.0	18.6	19.1	19.4	18.9	19.4	19.7	17.9	17.3	16.9	15.6	15.1	14.8	14.7	14.3	14.1
24.0	15.7	16.1	16.4	16.0	16.4	16.7	16.7	16.3	16.0	14.7	14.3	14.0	13.9	13.5	13.3
26.0	13.4	13.7	13.9	13.7	14.0	14.3	14.3	14.7	14.9	13.9	13.5	13.3	13.1	12.8	12.6
28.0	11.4	11.7	11.9	11.7	12.0	12.2	12.3	12.6	12.8	12.9	12.8	12.6	12.4	12.1	12.0
30.0	9.5	9.8	9.9	9.9	10.2	10.4	10.6	10.9	11.1	11.2	11.5	11.6	11.3	11.5	11.4
32.0	7.9	8.1	8.2	8.2	8.5	8.7	9.0	9.3	9.5	9.6	9.9	10.1	9.7	10.0	10.2
34.0	6.5	6.7	6.8	6.8	7.1	7.2	7.6	7.8	8.0	8.2	8.5	8.6	8.3	8.6	8.8
36.0	5.3	5.4		5.6	5.8	5.9	6.3	6.6	6.7	7.0	7.2	7.3	7.0	7.3	7.4
38.0	4.2	4.3		4.5	4.7	4.8	5.2	5.4	5.5	5.9	6.1	6.2	5.9	6.2	6.3
40.0	3.2	3.3		3.6	3.7		4.3	4.4	4.5	4.9	5.1	5.2	4.9	5.2	5.3
42.0	2.4			2.7	2.8		3.4	3.6	3.6	4.0	4.2	4.2	4.1	4.2	4.3
44.0							2.6	2.8		3.2	3.4	3.4	3.3	3.4	3.5
46.0							1.9	2.0		2.5	2.6	2.7	2.5	2.7	2.7
48.0										1.9	2.0		1.9	2.0	2.1
θ(°)	18~ 84.5	27~ 84.5	43~ 84.5	33~ 84.5	34~ 84.5	42~ 84.5	34~ 84.5	35~ 84.5	42~ 84.5	38~ 84.5	39~ 84.5	42~ 84.5	44~ 84.5	44~ 84.5	45~ 84.5
標準フック	80t						35t								
フック重量	1550kg						950kg								
標準巻掛本数	5						3								

カウンタウエイト 58t、アウトリガ張出幅 6.8m

ブーム+2.0m+11.5m油圧チルトジブ

単位:t

ブーム長さ(m) 作業半径 (m)	40.4			45.4			50.5			55.6			60.0		
	オフセット			オフセット			オフセット			オフセット			オフセット		
	0°	20°	40°	0°	20°	40°	0°	20°	40°	0°	20°	40°	0°	20°	40°
10.0	38.8														
11.0	36.7			31.1											
12.0	34.8			29.6			23.3								
14.0	31.5	27.6		27.0	23.4		21.2			18.8					
16.0	28.9	26.1	22.7	24.8	21.8		19.4	16.7		17.4	14.9		15.6		
18.0	26.6	24.2	21.8	23.0	20.4	18.8	18.0	15.8	14.0	16.0	14.0		15.1		
20.0	22.9	22.6	21.0	21.5	19.2	17.8	16.7	15.0	13.4	14.9	13.2	12.0	14.0	12.5	
22.0	19.3	21.0	20.1	19.6	18.1	16.9	15.6	14.1	12.8	13.9	12.5	11.4	13.1	11.9	
24.0	16.5	17.9	19.0	16.7	17.2	16.1	14.7	13.3	12.3	13.0	11.9	10.9	12.3	11.3	10.4
26.0	14.1	15.4	16.4	14.3	15.6	15.3	13.8	12.6	11.9	12.2	11.3	10.5	11.5	10.7	9.9
28.0	12.1	13.3	14.2	12.4	13.5	14.4	12.7	12.0	11.4	11.5	10.8	10.0	10.9	10.2	9.5
30.0	10.4	11.5	12.3	10.6	11.7	12.5	11.0	11.4	10.9	10.9	10.2	9.7	10.3	9.7	9.2
32.0	8.8	9.9	10.6	9.0	10.2	10.9	9.4	10.5	10.4	9.9	9.7	9.3	9.7	9.2	8.8
34.0	7.4	8.4	9.1	7.6	8.7	9.5	8.0	9.1	9.8	8.5	9.3	8.9	8.3	8.7	8.4
36.0	6.1	7.1	7.7	6.4	7.3	8.0	6.8	7.7	8.5	7.2	8.2	8.5	7.1	8.1	8.1
38.0	5.1	5.9	6.4	5.3	6.2	6.8	5.7	6.6	7.2	6.1	7.0	7.7	6.0	6.9	7.6
40.0	4.1	4.8	5.2	4.3	5.1	5.6	4.7	5.5	6.1	5.2	6.0	6.6	5.0	5.9	6.5
42.0	3.2	3.9	4.2	3.4	4.1	4.6	3.8	4.6	5.1	4.3	5.0	5.6	4.1	4.9	5.5
44.0	2.5	3.0		2.7	3.3	3.6	3.0	3.7	4.1	3.5	4.2	4.7	3.3	4.1	4.6
46.0				2.0	2.5	2.8	2.3	2.9	3.3	2.8	3.4	3.8	2.6	3.3	3.8
48.0					1.8		1.7	2.2	2.5	2.1	2.7	3.1	2.0	2.6	3.0
50.0							1.6	1.8	1.5	2.1	2.4		1.9	2.3	
θ(°)	34~ 83	38~ 84.5	44~ 84.5	38~ 83	38~ 84.5	44~ 84.5	41~ 83	42~ 84.5	43~ 84.5	44~ 83	47~ 84.5	49~ 84.5	50~ 83	51~ 84.5	53~ 84.5
標準フック	80t						35t								
フック重量	1550kg						950kg								
標準巻掛本数	4						3								

油圧チルトジブ

カウンタウエイト 58t、アウトリガ張出幅 6.8m

ブーム+2.0m+17.5m油圧チルトジブ

単位:t

ブーム長さ(m) 作業半径 (m)	40.4			45.4			50.5			55.6			60.0		
	オフセット			オフセット			オフセット			オフセット			オフセット		
	0°	20°	40°	0°	20°	40°	0°	20°	40°	0°	20°	40°	0°	20°	40°
11.0	31.5														
12.0	30.3			27.0											
14.0	28.1			24.6					19.5						
16.0	26.3	20.6		22.6					17.9			15.6			14.8
18.0	24.6	19.5		20.8	17.9				16.5	13.4		14.5			13.7
20.0	22.8	18.6		19.4	16.8				15.3	12.7		13.5	11.3		12.8
22.0	19.9	17.8	14.0	18.1	15.8				14.3	12.0		12.6	10.7		12.0 10.2
24.0	17.0	17.1	13.6	17.0	15.0	13.7	13.4	11.5	10.1	11.9	10.1			11.2	9.6
26.0	14.7	16.4	13.3	14.7	14.2	13.1	12.5	11.0	9.7	11.1	9.6	8.7	10.5	9.2	8.3
28.0	12.7	14.4	12.9	12.7	13.5	12.5	11.8	10.5	9.3	10.5	9.2	8.3	9.9	8.7	7.9
30.0	11.0	12.5	12.7	11.0	12.6	12.0	11.2	10.1	9.0	9.9	8.8	8.0	9.3	8.4	7.6
32.0	9.4	10.9	12.1	9.4	11.0	11.5	9.8	9.6	8.7	9.3	8.4	7.7	8.8	8.0	7.3
34.0	8.0	9.5	10.5	8.0	9.6	10.6	8.4	9.2	8.5	8.6	8.1	7.4	8.3	7.7	7.1
36.0	6.7	8.2	9.2	6.7	8.2	9.3	7.1	8.7	8.2	7.4	7.7	7.1	7.2	7.4	6.8
38.0	5.6	6.9	7.9	5.6	7.0	8.1	6.0	7.4	8.0	6.3	7.4	6.9	6.0	7.0	6.6
40.0	4.6	5.8	6.7	4.6	5.9	6.9	5.0	6.3	7.3	5.3	6.6	6.7	5.1	6.4	6.4
42.0	3.8	4.8	5.6	3.8	4.9	5.8	4.2	5.3	6.2	4.4	5.6	6.5	4.2	5.4	6.2
44.0	3.0	3.9	4.6	3.0	4.0	4.8	3.4	4.4	5.2	3.6	4.7	5.5	3.4	4.5	5.4
46.0	2.3	3.1	3.6	2.3	3.2	3.9	2.6	3.6	4.3	2.9	3.9	4.6	2.7	3.7	4.5
48.0	1.7	2.4	2.8	1.6	2.5	3.0	2.0	2.9	3.5	2.2	3.2	3.8		3.0	3.7
50.0		1.7			1.8	2.2		2.2	2.8	1.6	2.5	3.1		2.3	3.0
54.0												1.8			
θ(°)	36~ 83	38~ 84.5	44~ 84.5	42~ 83	45~ 84.5	48~ 84.5	47~ 83	50~ 84.5	53~ 84.5	49~ 83	54~ 84.5	52~ 84.5	56~ 83	57~ 84.5	60~ 84.5
標準フック	35t						35t								
フック重量	950kg						950kg								
標準巻掛本数	3						2								

カウンタウエイト 58t、アウトリガ張出幅 6.8m

ブーム+2.0m+23.5m油圧チルトジブ

単位:t

ブーム長さ(m) 作業半径 (m)	40.4			45.4			50.5			55.6			60.0		
	オフセット			オフセット			オフセット			オフセット			オフセット		
	0°	20°	40°	0°	20°	40°	0°	20°	40°	0°	20°	40°	0°	20°	40°
12.0	25.7														
14.0	23.9			22.1					17.6						
16.0	22.2			20.7					16.2			14.2			
18.0	20.8			19.3					15.0			13.1			12.4
20.0	19.6	14.4		17.9					14.0			12.2			11.6
22.0	18.5	13.6		16.7	13.8				13.1	10.3		11.4			10.8
24.0	17.5	12.9		15.6	13.2				12.2	9.8		10.6	8.8		10.1
26.0	15.1	12.3	9.3	14.7	12.6				11.4	9.4		10.0	8.3	9.5	8.0
28.0	13.1	11.7	9.0	13.1	12.1	9.1	10.7	9.0		9.4	7.9		9.0	7.6	
30.0	11.4	11.2	8.7	11.4	11.5	8.9	10.1	8.6	7.5	8.9	7.6	6.7	8.5	7.2	
32.0	9.9	10.7	8.5	9.8	11.0	8.6	9.6	8.2	7.2	8.5	7.2	6.5	8.0	6.9	6.2
34.0	8.5	10.3	8.3	8.4	10.3	8.4	8.6	7.9	7.0	8.0	6.9	6.2	7.6	6.6	6.0
36.0	7.2	9.1	8.1	7.1	9.1	8.2	7.3	7.6	6.8	7.4	6.6	6.0	7.2	6.3	5.7
38.0	6.1	7.9	7.9	6.0	7.9	8.1	6.2	7.3	6.5	6.3	6.4	5.8	6.1	6.1	5.5
40.0	5.1	6.7	7.7	5.0	6.7	7.9	5.2	6.9	6.3	5.3	6.1	5.6	5.1	5.8	5.3
42.0	4.2	5.7	6.9	4.1	5.7	7.0	4.3	5.9	6.2	4.4	5.9	5.4	4.2	5.6	5.1
44.0	3.4	4.8	5.8	3.3	4.8	5.9	3.5	5.0	6.0	3.6	5.1	5.2	3.4	5.0	4.9
46.0	2.7	3.9	4.9	2.6	3.9	5.0	2.8	4.1	5.2	2.9	4.3	5.0	2.7	4.1	4.7
48.0	2.0	3.2	4.0	2.0	3.2	4.1	2.1	3.4	4.4	2.3	3.6	4.6		3.4	4.5
50.0		2.4	3.1		2.5	3.3		2.7	3.6		2.9	3.8		2.7	3.7
54.0			1.6			1.8			2.2				2.4		
θ(°)	43~ 83	47~ 84.5	45~ 84.5	48~ 83	53~ 84.5	52~ 84.5	52~ 83	56~ 84.5	56~ 84.5	55~ 83	60~ 84.5	60~ 84.5	59~ 83	62~ 84.5	66~ 84.5
標準フック	35t						35t								
フック重量	950kg						950kg								
標準巻掛本数	3						2								

カウンタウエイト 58t、アウトリガ張出幅 6.8m
 ブーム+2.0m+29.5m油圧チルトジブ

単位:t

ブーム長さ(m) 作業半径 (m)	40.4			45.4			50.5			55.6			60.0		
	オフセット			オフセット			オフセット			オフセット			オフセット		
	0°	20°	40°	0°	20°	40°	0°	20°	40°	0°	20°	40°	0°	20°	40°
14.0	20.4			18.9											
16.0	19.0			17.7			14.7								
18.0	17.8			16.7			13.6					12.4			
20.0	16.7			15.7			12.6					11.4			10.9
22.0	15.8			14.9			11.7					10.6			10.1
24.0	14.9	10.2		14.1	10.5		11.0					9.9			9.5
26.0	14.1	9.6		13.4	9.9		10.3	8.2				9.3			8.9
28.0	13.3	9.1		12.7	9.4		9.8	7.8				8.7	7.2		8.3
30.0	11.6	8.7		11.5	9.0		9.2	7.4				8.2	6.8		7.9
32.0	10.1	8.3	6.2	10.0	8.6	6.3	8.7	7.1				7.8	6.5		7.4
34.0	8.7	7.9	6.0	8.5	8.2	6.1	8.2	6.8	5.9			7.4	6.2		7.0
36.0	7.4	7.6	5.9	7.3	7.9	6.0	7.3	6.5	5.7	7.0	5.9	5.3	6.7	5.5	
38.0	6.3	7.2	5.7	6.1	7.5	5.8	6.2	6.3	5.5	6.6	5.7	5.1	6.3	5.2	4.4
40.0	5.3	6.9	5.5	5.1	7.2	5.6	5.2	6.0	5.3	5.6	5.4	4.9	5.3	4.9	4.2
42.0	4.4	6.3	5.4	4.2	6.2	5.5	4.3	5.8	5.1	4.7	5.2	4.7	4.4	4.6	4.0
44.0	3.6	5.3	5.3	3.4	5.3	5.4	3.5	5.4	5.0	3.9	5.0	4.5	3.6	4.3	3.8
46.0	2.9	4.5	5.1	2.7	4.4	5.2	2.8	4.5	4.8	3.1	4.8	4.3		4.1	3.6
48.0	2.2	3.7	4.9	2.1	3.6	5.0		3.8	4.7			4.1	4.2		3.9
50.0	1.6	3.0	4.1		2.9	4.1		3.1	4.3			3.4	4.1		3.2
54.0		1.7	2.5			2.6			2.8				3.2		3.0
θ(°)	46~ 83	50~ 84.5	55~ 84.5	52~ 83	58~ 84.5	60~ 84.5	57~ 83	61~ 84.5	63~ 84.5	60~ 83	64~ 84.5	66~ 84.5	64~ 83	66~ 84.5	68~ 84.5
標準フック	35t												12.2t		
フック重量	950kg												440kg		
標準巻掛本数	2												1		

カウンタウエイト 58t、アウトリガ張出幅 6.8m
 ブーム+2.0m+35.5m油圧チルトジブ

単位:t

ブーム長さ(m) 作業半径 (m)	40.4			45.4			50.5			55.6			60.0		
	オフセット			オフセット			オフセット			オフセット			オフセット		
	0°	20°	40°	0°	20°	40°	0°	20°	40°	0°	20°	40°	0°	20°	40°
14.0	17.2														
16.0	16.2			15.1											
18.0	15.3			14.3			12.9								
20.0	14.5			13.6			12.0					10.6			
22.0	13.7			12.9			11.1					9.8			9.4
24.0	12.8			12.3			10.4					9.2			8.7
26.0	12.0	7.9		11.7			9.8					8.6			8.2
28.0	11.3	7.5		11.1	7.7		9.2					8.0			7.7
30.0	10.7	7.1		10.6	7.3		8.7	6.8				7.5			7.2
32.0	10.1	6.7		10.1	6.9		8.2	6.5				7.1	5.8		6.8
34.0	9.0	6.4		8.8	6.6		7.8	6.2				6.7	5.6		6.4
36.0	7.7	6.1	4.5	7.5	6.3		7.4	5.9				6.4	5.3		6.1
38.0	6.6	5.8	4.3	6.4	6.0	4.4	6.7	5.7				6.0	5.0		5.8
40.0	5.6	5.5	4.2	5.4	5.7	4.2	5.7	5.5	4.5	5.7	4.8			5.3	4.1
42.0	4.7	5.3	4.0	4.5	5.5	4.1	4.8	5.2	4.4	4.8	4.6	4.1	4.6	3.9	3.3
44.0	3.9	5.0	3.9	3.7	5.3	4.0	4.0	5.0	4.3	4.0	4.4	3.9	3.7	3.6	3.1
46.0	3.1	4.8	3.8	2.9	5.0	3.9	3.2	4.8	4.1	3.3	4.2	3.7		3.4	2.9
48.0	2.5	4.3	3.7	2.3	4.2	3.7	2.6	4.5	4.0			4.0	3.5		3.2
50.0	1.9	3.6	3.6		3.5	3.7		3.8	3.9			3.8	3.3		3.0
54.0		2.3	3.4		2.2	3.5		2.5	3.7				3.0		2.3
58.0			2.2						2.5						
θ(°)	51~ 83	56~ 84.5	58~ 84.5	56~ 83	60~ 84.5	66~ 84.5	59~ 83	63~ 84.5	66~ 84.5	63~ 83	68~ 84.5	72~ 84.5	66~ 83	70~ 84.5	73~ 84.5
標準フック	35t												12.2t		
フック重量	950kg												440kg		
標準巻掛本数	2												1		

油圧チルトジブ

カウンタウエイト 47t、アウトリガ張出幅 8.5m

ブーム+2.0m+3.5m油圧チルトジブ

単位:t

ブーム長さ(m) 作業半径 (m)	40.4			45.4			50.5			55.6			60.0		
	オフセット			オフセット			オフセット			オフセット			オフセット		
	0°	20°	40°	0°	20°	40°	0°	20°	40°	0°	20°	40°	0°	20°	40°
8.0	47.7														
9.0	44.9	42.5		38.0											
10.0	42.5	40.3	38.9	36.1	33.9			28.4							
11.0	40.3	38.4	37.1	34.4	32.4	31.1	27.0	25.5		23.9					
12.0	38.3	36.6	35.5	32.9	31.1	29.9	25.7	24.4	23.5	22.8	21.5				
14.0	35.0	33.6	32.7	30.3	28.8	27.8	23.6	22.5	21.7	20.8	19.9	19.2	19.7		
16.0	32.2	31.0	30.3	28.1	26.8	26.0	21.8	20.9	20.3	19.2	18.5	18.0	18.2	17.5	17.1
18.0	29.3	28.9	28.3	26.0	25.1	24.4	20.3	19.5	19.0	17.8	17.2	16.8	16.9	16.3	15.9
20.0	24.2	24.8	25.2	24.2	23.6	23.1	19.0	18.3	17.9	16.6	16.1	15.8	15.7	15.2	14.9
22.0	20.3	20.8	21.1	20.6	21.1	21.4	17.9	17.3	16.9	15.6	15.1	14.8	14.7	14.3	14.1
24.0	17.1	17.5	17.8	17.4	17.9	18.1	16.9	16.3	16.0	14.7	14.3	14.0	13.9	13.5	13.3
26.0	14.6	14.9	15.1	14.9	15.2	15.4	15.5	15.5	15.2	13.9	13.5	13.3	13.1	12.8	12.6
28.0	12.4	12.7	12.9	12.7	13.0	13.2	13.3	13.7	13.9	13.1	12.8	12.6	12.4	12.1	12.0
30.0	10.5	10.8	11.0	10.9	11.2	11.3	11.5	11.8	12.0	12.1	12.2	12.1	11.8	11.5	11.4
32.0	8.8	9.0	9.1	9.1	9.4	9.6	9.9	10.2	10.4	10.5	10.8	10.9	10.6	10.9	10.9
34.0	7.3	7.5	7.6	7.6	7.9	8.0	8.4	8.7	8.8	9.0	9.3	9.5	9.1	9.4	9.6
36.0	6.0	6.1		6.3	6.6	6.6	7.1	7.3	7.4	7.7	8.0	8.1	7.8	8.1	8.2
38.0	4.8	5.0		5.2	5.4	5.4	5.9	6.1	6.2	6.5	6.8	6.9	6.6	6.8	7.0
40.0	3.8	3.9		4.2	4.3		4.9	5.1	5.1	5.5	5.7	5.8	5.6	5.8	5.9
42.0	3.0			3.3	3.4		4.0	4.1	4.1	4.6	4.7	4.8	4.6	4.8	4.9
44.0				2.5	2.6		3.1	3.3		3.7	3.9	3.9	3.8	4.0	4.0
46.0							2.4	2.5		3.0	3.1	3.2	3.0	3.2	3.2
48.0							1.7	1.8		2.3	2.4		2.3	2.5	2.5
50.0										1.7	1.8		1.7	1.8	
θ(°)	18~ 84.5	27~ 84.5	43~ 84.5	28~ 84.5	29~ 84.5	42~ 84.5	30~ 84.5	30~ 84.5	42~ 84.5	35~ 84.5	35~ 84.5	42~ 84.5	41~ 84.5	42~ 84.5	45~ 84.5
標準フック	80t			80t			35t								
フック重量	1550kg			1550kg			950kg								
標準巻掛本数	5			4			3								

カウンタウエイト 47t、アウトリガ張出幅 8.5m

ブーム+2.0m+11.5m油圧チルトジブ

単位:t

ブーム長さ(m) 作業半径 (m)	40.4			45.4			50.5			55.6			60.0		
	オフセット			オフセット			オフセット			オフセット			オフセット		
	0°	20°	40°	0°	20°	40°	0°	20°	40°	0°	20°	40°	0°	20°	40°
10.0	38.8														
11.0	36.7			31.1											
12.0	34.8			29.6			23.3								
14.0	31.5	27.6		27.0	23.4		21.2			18.8					
16.0	28.9	26.1	22.7	24.8	21.8		19.4	16.7		17.4	14.9		15.6		
18.0	26.6	24.2	21.8	23.0	20.4	18.8	18.0	15.8	14.0	16.0	14.0		15.1		
20.0	24.7	22.6	21.0	21.5	19.2	17.8	16.7	15.0	13.4	14.9	13.2	12.0	14.0	12.5	
22.0	21.1	21.3	20.1	20.1	18.1	16.9	15.6	14.1	12.8	13.9	12.5	11.4	13.1	11.9	
24.0	17.9	19.4	19.0	18.2	17.2	16.1	14.7	13.3	12.3	13.0	11.9	10.9	12.3	11.3	10.4
26.0	15.3	16.7	17.7	15.6	16.3	15.3	13.8	12.6	11.9	12.2	11.3	10.5	11.5	10.7	9.9
28.0	13.2	14.4	15.3	13.4	14.6	14.7	13.1	12.0	11.4	11.5	10.8	10.0	10.9	10.2	9.5
30.0	11.4	12.4	13.2	11.6	12.7	13.5	11.9	11.4	10.9	10.9	10.2	9.7	10.3	9.7	9.2
32.0	9.7	10.8	11.5	10.0	11.0	11.8	10.4	10.9	10.4	10.3	9.7	9.3	9.7	9.2	8.8
34.0	8.2	9.3	9.9	8.5	9.6	10.2	8.9	9.9	10.0	9.4	9.3	8.9	9.2	8.7	8.4
36.0	6.9	7.8	8.5	7.1	8.1	8.8	7.5	8.6	9.2	8.0	8.9	8.5	7.9	8.4	8.1
38.0	5.7	6.6	7.1	6.0	6.9	7.5	6.4	7.3	8.0	6.8	7.8	8.2	6.7	7.7	7.7
40.0	4.7	5.5	5.9	4.9	5.8	6.3	5.3	6.2	6.8	5.8	6.7	7.3	5.6	6.5	7.2
42.0	3.8	4.5	4.8	4.0	4.7	5.2	4.4	5.2	5.7	4.9	5.7	6.2	4.7	5.5	6.1
44.0	3.0	3.5		3.2	3.8	4.2	3.6	4.3	4.7	4.0	4.8	5.2	3.9	4.6	5.2
46.0		2.7		2.5	3.0	3.3	2.8	3.5	3.8	3.3	3.9	4.4	3.1	3.8	4.3
48.0				1.8	2.3		2.2	2.7	3.0	2.6	3.2	3.6	2.4	3.1	3.5
50.0					1.6		1.6	2.0	2.3	2.0	2.5	2.8	1.8	2.4	2.8
54.0												1.5			1.5
θ(°)	34~ 83	33~ 84.5	44~ 84.5	34~ 83	34~ 84.5	44~ 84.5	38~ 83	42~ 84.5	43~ 84.5	44~ 83	47~ 84.5	43~ 84.5	48~ 83	51~ 84.5	48~ 84.5
標準フック	80t			35t											
フック重量	1550kg			950kg											
標準巻掛本数	4			3											

カウンタウエイト 47t、アウトリガ張出幅 8.5m

ブーム+2.0m+17.5m油圧チルトジブ

単位:t

ブーム長さ(m) 作業半径 (m)	40.4			45.4			50.5			55.6			60.0			
	オフセット			オフセット			オフセット			オフセット			オフセット			
	0°	20°	40°	0°	20°	40°	0°	20°	40°	0°	20°	40°	0°	20°	40°	
11.0	31.5															
12.0	30.3			27.0												
14.0	28.1			24.6					19.5							
16.0	26.3	20.6		22.6					17.9			15.6			14.8	
18.0	24.6	19.5		20.8	17.9				16.5	13.4		14.5			13.7	
20.0	22.8	18.6		19.4	16.8				15.3	12.7		13.5	11.3		12.8	
22.0	21.2	17.8	14.0	18.1	15.8				14.3	12.0		12.6	10.7		12.0 10.2	
24.0	18.5	17.1	13.6	17.0	15.0	13.7			13.4	11.5	10.1	11.9	10.1		11.2 9.6	
26.0	15.9	16.4	13.3	15.9	14.2	13.1			12.5	11.0	9.7	11.1	9.6	8.7	10.5 9.2 8.3	
28.0	13.8	15.5	12.9	13.8	13.5	12.5			11.8	10.5	9.3	10.5	9.2	8.3	9.9 8.7 7.9	
30.0	11.9	13.5	12.7	11.9	12.9	12.0			11.2	10.1	9.0	9.9	8.8	8.0	9.3 8.4 7.6	
32.0	10.4	11.8	12.4	10.4	11.9	11.5			10.6	9.6	8.7	9.3	8.4	7.7	8.8 8.0 7.3	
34.0	8.9	10.3	11.4	8.9	10.4	11.1			9.3	9.2	8.5	8.8	8.1	7.4	8.3 7.7 7.1	
36.0	7.5	9.0	9.9	7.5	9.1	10.0			7.9	8.8	8.2	8.2	7.7	7.1	7.9 7.4 6.8	
38.0	6.4	7.7	8.7	6.3	7.8	8.8			6.8	8.2	8.0	7.0	7.4	6.9	6.8 7.0 6.6	
40.0	5.3	6.5	7.4	5.3	6.6	7.6			5.7	7.0	7.7	5.9	7.1	6.7	5.7 6.7 6.4	
42.0	4.4	5.5	6.2	4.4	5.5	6.4			4.8	6.0	6.9	5.0	6.2	6.5	4.8 6.1 6.2	
44.0	3.6	4.5	5.2	3.5	4.6	5.4			3.9	5.0	5.8	4.2	5.3	6.1	3.9 5.1 6.0	
46.0	2.8	3.7	4.2	2.8	3.8	4.4			3.2	4.2	4.9	3.4	4.4	5.2	3.2 4.3 5.1	
48.0	2.1	2.9	3.3	2.1	3.0	3.5			2.5	3.4	4.0	2.7	3.7	4.4	2.5 3.5 4.3	
50.0	1.5	2.2		1.5	2.3	2.7			1.9	2.7	3.2	2.1	3.0	3.6	2.8 3.5	
54.0											1.8		1.7	2.2		2.1
θ(°)	32~ 83	38~ 84.5	44~ 84.5	39~ 83	45~ 84.5	48~ 84.5	45~ 83	50~ 84.5	47~ 84.5	49~ 83	49~ 84.5	52~ 84.5	54~ 83	57~ 84.5	56~ 84.5	
標準フック	35t						35t									
フック重量	950kg						950kg									
標準巻掛本数	3						2									

カウンタウエイト 47t、アウトリガ張出幅 8.5m

ブーム+2.0m+23.5m油圧チルトジブ

単位:t

ブーム長さ(m) 作業半径 (m)	40.4			45.4			50.5			55.6			60.0			
	オフセット			オフセット			オフセット			オフセット			オフセット			
	0°	20°	40°	0°	20°	40°	0°	20°	40°	0°	20°	40°	0°	20°	40°	
12.0	25.7															
14.0	23.9			22.1					17.6							
16.0	22.2			20.7					16.2			14.2				
18.0	20.8			19.3					15.0			13.1			12.4	
20.0	19.6	14.4		17.9					14.0			12.2			11.6	
22.0	18.5	13.6		16.7	13.8				13.1	10.3		11.4			10.8	
24.0	17.5	12.9		15.6	13.2				12.2	9.8		10.6	8.8		10.1	
26.0	16.4	12.3	9.3	14.7	12.6				11.4	9.4		10.0	8.3		9.5 8.0	
28.0	14.3	11.7	9.0	13.8	12.1	9.1			10.7	9.0		9.4	7.9		9.0 7.6	
30.0	12.4	11.2	8.7	12.3	11.5	8.9			10.1	8.6	7.5	8.9	7.6	6.7	8.5 7.2	
32.0	10.8	10.7	8.5	10.8	11.0	8.6			9.6	8.2	7.2	8.5	7.2	6.5	8.0 6.9 6.2	
34.0	9.4	10.3	8.3	9.3	10.5	8.4			9.1	7.9	7.0	8.0	6.9	6.2	7.6 6.6 6.0	
36.0	8.0	9.8	8.1	8.0	9.8	8.2			8.1	7.6	6.8	7.6	6.6	6.0	7.2 6.3 5.7	
38.0	6.8	8.6	7.9	6.8	8.6	8.1			6.9	7.3	6.5	7.1	6.4	5.8	6.8 6.1 5.5	
40.0	5.8	7.5	7.7	5.7	7.5	7.9			5.9	7.1	6.3	6.0	6.1	5.6	5.8 5.8 5.3	
42.0	4.8	6.4	7.6	4.8	6.4	7.7			4.9	6.6	6.2	5.1	5.9	5.4	4.8 5.6 5.1	
44.0	4.0	5.4	6.5	3.9	5.4	6.6			4.1	5.6	6.0	4.2	5.7	5.2	4.0 5.4 4.9	
46.0	3.2	4.5	5.4	3.2	4.5	5.6			3.3	4.7	5.8	3.5	4.9	5.0	3.2 4.7 4.7	
48.0	2.6	3.7	4.5	2.5	3.7	4.6			2.6	3.9	4.9	2.8	4.1	4.9	2.5 3.9 4.5	
50.0	1.9	2.9	3.6	1.8	3.0	3.8			2.0	3.2	4.1	2.1	3.4	4.3	3.2 4.2	
54.0		1.6	2.1		1.7	2.3			1.9	2.6			2.1	2.9		2.8
θ(°)	40~ 83	41~ 84.5	45~ 84.5	46~ 83	48~ 84.5	52~ 84.5	50~ 83	52~ 84.5	56~ 84.5	53~ 83	56~ 84.5	60~ 84.5	58~ 83	62~ 84.5	63~ 84.5	
標準フック	35t						35t									
フック重量	950kg						950kg									
標準巻掛本数	3						2									

油圧チルトジブ

カウンタウエイト 47t、アウトリガ張出幅 8.5m

ブーム+2.0m+29.5m油圧チルトジブ

単位:t

ブーム長さ(m) 作業半径 (m)	40.4			45.4			50.5			55.6			60.0		
	オフセット			オフセット			オフセット			オフセット			オフセット		
	0°	20°	40°	0°	20°	40°	0°	20°	40°	0°	20°	40°	0°	20°	40°
14.0	20.4			18.9											
16.0	19.0			17.7			14.7								
18.0	17.8			16.7			13.6			12.4					
20.0	16.7			15.7			12.6			11.4			10.9		
22.0	15.8			14.9			11.7			10.6			10.1		
24.0	14.9	10.2		14.1	10.5		11.0			9.9			9.5		
26.0	14.1	9.6		13.4	9.9		10.3	8.2		9.3			8.9		
28.0	13.4	9.1		12.7	9.4		9.8	7.8		8.7	7.2		8.3		
30.0	12.6	8.7		11.9	9.0		9.2	7.4		8.2	6.8		7.9	6.5	
32.0	11.0	8.3	6.2	10.9	8.6	6.3	8.7	7.1		7.8	6.5		7.4	6.2	
34.0	9.6	7.9	6.0	9.5	8.2	6.1	8.2	6.8	5.9	7.4	6.2		7.0	5.9	
36.0	8.3	7.6	5.9	8.1	7.9	6.0	7.8	6.5	5.7	7.0	5.9	5.3	6.7	5.5	
38.0	7.1	7.2	5.7	6.9	7.5	5.8	7.0	6.3	5.5	6.7	5.7	5.1	6.3	5.2	4.4
40.0	6.0	6.9	5.5	5.8	7.2	5.6	5.9	6.0	5.3	6.3	5.4	4.9	5.9	4.9	4.2
42.0	5.0	6.7	5.4	4.9	6.9	5.5	5.0	5.8	5.1	5.3	5.2	4.7	5.1	4.6	4.0
44.0	4.2	6.0	5.3	4.0	5.9	5.4	4.1	5.6	5.0	4.5	5.0	4.5	4.2	4.3	3.8
46.0	3.4	5.1	5.1	3.3	5.0	5.2	3.4	5.1	4.8	3.7	4.8	4.3	3.4	4.1	3.6
48.0	2.7	4.3	5.0	2.6	4.2	5.1	2.7	4.3	4.7	3.0	4.6	4.2		3.9	3.4
50.0	2.1	3.5	4.6	1.9	3.4	4.7		3.6	4.6		3.9	4.1		3.6	3.3
54.0		2.1	3.0		2.1	3.1		2.2	3.3		2.6	3.7			3.0
58.0			1.6			1.7						2.4			
θ(°)	46~ 83	50~ 84.5	49~ 84.5	50~ 83	54~ 84.5	55~ 84.5	56~ 83	58~ 84.5	63~ 84.5	59~ 83	61~ 84.5	63~ 84.5	62~ 83	66~ 84.5	68~ 84.5
標準フック	35t												12.2t		
フック重量	950kg												440kg		
標準巻掛本数	2												1		

カウンタウエイト 47t、アウトリガ張出幅 8.5m

ブーム+2.0m+35.5m油圧チルトジブ

単位:t

ブーム長さ(m) 作業半径 (m)	40.4			45.4			50.5			55.6			60.0		
	オフセット			オフセット			オフセット			オフセット			オフセット		
	0°	20°	40°	0°	20°	40°	0°	20°	40°	0°	20°	40°	0°	20°	40°
14.0	17.2														
16.0	16.2			15.1											
18.0	15.3			14.3			12.9								
20.0	14.5			13.6			12.0			10.6					
22.0	13.7			12.9			11.1			9.8			9.4		
24.0	12.8			12.3			10.4			9.2			8.7		
26.0	12.0	7.9		11.7			9.8			8.6			8.2		
28.0	11.3	7.5		11.1	7.7		9.2			8.0			7.7		
30.0	10.7	7.1		10.6	7.3		8.7	6.8		7.5			7.2		
32.0	10.1	6.7		10.1	6.9		8.2	6.5		7.1	5.8		6.8	5.4	
34.0	9.6	6.4		9.7	6.6		7.8	6.2		6.7	5.6		6.4	5.0	
36.0	8.6	6.1	4.5	8.4	6.3		7.4	5.9		6.4	5.3		6.1	4.7	
38.0	7.4	5.8	4.3	7.2	6.0	4.4	7.0	5.7		6.0	5.0		5.8	4.4	
40.0	6.3	5.5	4.2	6.1	5.7	4.2	6.4	5.5	4.5	5.7	4.8		5.3	4.1	
42.0	5.4	5.3	4.0	5.2	5.5	4.1	5.5	5.2	4.4	5.5	4.6	4.1	4.9	3.9	3.3
44.0	4.5	5.0	3.9	4.3	5.3	4.0	4.6	5.0	4.3	4.6	4.4	3.9	4.4	3.6	3.1
46.0	3.7	4.8	3.8	3.5	5.0	3.9	3.8	4.8	4.1	3.9	4.2	3.7	3.6	3.4	2.9
48.0	3.0	4.6	3.7	2.8	4.8	3.7	3.1	4.7	4.0	3.1	4.0	3.5		3.2	2.7
50.0	2.4	4.1	3.6	2.2	4.0	3.7	2.5	4.3	3.9		3.8	3.3		3.0	2.6
54.0		2.8	3.4		2.7	3.5		3.0	3.7		3.0	3.0			2.3
58.0		1.6	2.6			2.6			3.0			2.7			
θ(°)	51~ 83	52~ 84.5	58~ 84.5	54~ 83	60~ 84.5	62~ 84.5	57~ 83	63~ 84.5	66~ 84.5	61~ 83	65~ 84.5	69~ 84.5	65~ 83	70~ 84.5	73~ 84.5
標準フック	35t												12.2t		
フック重量	950kg												440kg		
標準巻掛本数	2												1		

カウンタウエイト 47t、アウトリガ張出幅 8.0m

ブーム+2.0m+3.5m油圧チルトジブ

単位:t

ブーム長さ(m) 作業半径 (m)	40.4			45.4			50.5			55.6			60.0			
	オフセット			オフセット			オフセット			オフセット			オフセット			
	0°	20°	40°	0°	20°	40°	0°	20°	40°	0°	20°	40°	0°	20°	40°	
8.0	47.7															
9.0	44.9	42.5		38.0												
10.0	42.5	40.3	38.9	36.1	33.9			28.4								
11.0	40.3	38.4	37.1	34.4	32.4	31.1	27.0	25.5		23.9						
12.0	38.3	36.6	35.5	32.9	31.1	29.9	25.7	24.4	23.5	22.8	21.5					
14.0	35.0	33.6	32.7	30.3	28.8	27.8	23.6	22.5	21.7	20.8	19.9	19.2	19.7			
16.0	32.2	31.0	30.3	28.1	26.8	26.0	21.8	20.9	20.3	19.2	18.5	18.0	18.2	17.5	17.1	
18.0	27.1	27.8	28.3	26.0	25.1	24.4	20.3	19.5	19.0	17.8	17.2	16.8	16.9	16.3	15.9	
20.0	22.4	22.9	23.3	22.7	23.3	23.1	19.0	18.3	17.9	16.6	16.1	15.8	15.7	15.2	14.9	
22.0	18.7	19.1	19.5	19.0	19.5	19.8	17.9	17.3	16.9	15.6	15.1	14.8	14.7	14.3	14.1	
24.0	15.7	16.1	16.4	16.0	16.4	16.7	16.7	16.3	16.0	14.7	14.3	14.0	13.9	13.5	13.3	
26.0	13.3	13.7	13.9	13.6	14.0	14.2	14.2	14.6	14.8	13.9	13.5	13.3	13.1	12.8	12.6	
28.0	11.3	11.6	11.8	11.6	11.9	12.1	12.2	12.5	12.7	12.8	12.8	12.6	12.4	12.1	12.0	
30.0	9.4	9.7	9.8	9.7	10.1	10.3	10.5	10.8	11.0	11.1	11.3	11.5	11.1	11.4	11.4	
32.0	7.7	8.0	8.1	8.1	8.4	8.5	8.8	9.2	9.3	9.5	9.8	10.0	9.6	9.9	10.1	
34.0	6.3	6.5	6.6	6.7	6.9	7.0	7.4	7.7	7.8	8.1	8.4	8.5	8.1	8.4	8.6	
36.0	5.1	5.2		5.4	5.7	5.7	6.2	6.4	6.5	6.8	7.1	7.2	6.9	7.1	7.3	
38.0	4.0	4.1		4.3	4.5	4.6	5.1	5.3	5.4	5.7	5.9	6.0	5.8	6.0	6.1	
40.0	3.1	3.1		3.4	3.5		4.1	4.3	4.3	4.7	4.9	5.0	4.8	5.0	5.1	
42.0				2.5	2.7		3.2	3.4	3.4	3.8	4.0	4.1	3.9	4.1	4.2	
44.0							2.4	2.6		3.0	3.2	3.2	3.1	3.3	3.3	
46.0							1.7	1.8		2.3	2.5	2.5	2.4	2.5	2.6	
48.0										1.7	1.8		1.7	1.8	1.9	
θ(°)	26~ 84.5	27~ 84.5	43~ 84.5	33~ 84.5	34~ 84.5	42~ 84.5	34~ 84.5	35~ 84.5	42~ 84.5	38~ 84.5	39~ 84.5	42~ 84.5	44~ 84.5	44~ 84.5	45~ 84.5	
標準フック	80t						80t						35t			
フック重量	1550kg						1550kg						950kg			
標準巻掛本数	5						4						3			

カウンタウエイト 47t、アウトリガ張出幅 8.0m

ブーム+2.0m+11.5m油圧チルトジブ

単位:t

ブーム長さ(m) 作業半径 (m)	40.4			45.4			50.5			55.6			60.0			
	オフセット			オフセット			オフセット			オフセット			オフセット			
	0°	20°	40°	0°	20°	40°	0°	20°	40°	0°	20°	40°	0°	20°	40°	
10.0	38.8															
11.0	36.7			31.1												
12.0	34.8			29.6			23.3									
14.0	31.5	27.6		27.0	23.4		21.2			18.8						
16.0	28.9	26.1	22.7	24.8	21.8		19.4	16.7		17.4	14.9		15.6			
18.0	26.6	24.2	21.8	23.0	20.4	18.8	18.0	15.8	14.0	16.0	14.0		15.1			
20.0	23.2	22.6	21.0	21.5	19.2	17.8	16.7	15.0	13.4	14.9	13.2	12.0	14.0	12.5		
22.0	19.5	21.2	20.1	19.7	18.1	16.9	15.6	14.1	12.8	13.9	12.5	11.4	13.1	11.9		
24.0	16.5	18.0	19.0	16.7	17.2	16.1	14.7	13.3	12.3	13.0	11.9	10.9	12.3	11.3	10.4	
26.0	14.1	15.4	16.4	14.3	15.6	15.3	13.8	12.6	11.9	12.2	11.3	10.5	11.5	10.7	9.9	
28.0	12.1	13.2	14.1	12.3	13.5	14.4	12.6	12.0	11.4	11.5	10.8	10.0	10.9	10.2	9.5	
30.0	10.3	11.4	12.2	10.6	11.6	12.5	10.9	11.4	10.9	10.9	10.2	9.7	10.3	9.7	9.2	
32.0	8.7	9.8	10.5	8.9	10.1	10.8	9.3	10.4	10.4	9.8	9.7	9.3	9.6	9.2	8.8	
34.0	7.2	8.3	9.0	7.5	8.6	9.4	7.9	9.0	9.7	8.4	9.3	8.9	8.2	8.7	8.4	
36.0	6.0	6.9	7.6	6.2	7.2	7.9	6.6	7.6	8.4	7.1	8.1	8.5	6.9	8.0	8.1	
38.0	4.9	5.7	6.2	5.1	6.0	6.6	5.5	6.4	7.1	6.0	6.9	7.6	5.8	6.8	7.5	
40.0	3.9	4.7	5.1	4.1	4.9	5.5	4.5	5.4	5.9	5.0	5.9	6.5	4.8	5.7	6.4	
42.0	3.1	3.7	4.0	3.3	4.0	4.4	3.7	4.4	4.9	4.1	4.9	5.4	4.0	4.8	5.4	
44.0		2.8		2.5	3.1	3.5	2.9	3.6	4.0	3.3	4.0	4.5	3.2	3.9	4.4	
46.0				1.8	2.3	2.6	2.2	2.8	3.1	2.6	3.3	3.7	2.4	3.1	3.6	
48.0					1.6		1.5	2.1	2.4	2.0	2.5	2.9	1.8	2.4	2.8	
50.0									1.7		1.9	2.2		1.8	2.1	
θ(°)	37~ 83	38~ 84.5	44~ 84.5	38~ 83	38~ 84.5	44~ 84.5	41~ 83	45~ 84.5	43~ 84.5	46~ 83	47~ 84.5	49~ 84.5	50~ 83	51~ 84.5	53~ 84.5	
標準フック	80t						80t						35t			
フック重量	1550kg						1550kg						950kg			
標準巻掛本数	4						4						3			

油圧チルトジブ

カウンタウエイト 47t、アウトリガ張出幅 8.0m

ブーム+2.0m+17.5m油圧チルトジブ

単位:t

ブーム長さ(m) 作業半径 (m)	40.4			45.4			50.5			55.6			60.0		
	オフセット			オフセット			オフセット			オフセット			オフセット		
	0°	20°	40°	0°	20°	40°	0°	20°	40°	0°	20°	40°	0°	20°	40°
11.0	31.5														
12.0	30.3			27.0											
14.0	28.1			24.6			19.5								
16.0	26.3	20.6		22.6			17.9			15.6			14.8		
18.0	24.6	19.5		20.8	17.9		16.5	13.4		14.5			13.7		
20.0	22.8	18.6		19.4	16.8		15.3	12.7		13.5	11.3		12.8		
22.0	20.1	17.8	14.0	18.1	15.8		14.3	12.0		12.6	10.7		12.0	10.2	
24.0	17.1	17.1	13.6	17.0	15.0	13.7	13.4	11.5	10.1	11.9	10.1		11.2	9.6	
26.0	14.7	16.4	13.3	14.7	14.2	13.1	12.5	11.0	9.7	11.1	9.6	8.7	10.5	9.2	8.3
28.0	12.6	14.4	12.9	12.6	13.5	12.5	11.8	10.5	9.3	10.5	9.2	8.3	9.9	8.7	7.9
30.0	10.9	12.5	12.7	10.9	12.5	12.0	11.2	10.1	9.0	9.9	8.8	8.0	9.3	8.4	7.6
32.0	9.3	10.8	12.0	9.3	10.9	11.5	9.7	9.6	8.7	9.3	8.4	7.7	8.8	8.0	7.3
34.0	7.9	9.4	10.5	7.9	9.5	10.6	8.3	9.2	8.5	8.5	8.1	7.4	8.3	7.7	7.1
36.0	6.6	8.1	9.1	6.6	8.1	9.2	7.0	8.6	8.2	7.3	7.7	7.1	7.0	7.4	6.8
38.0	5.5	6.8	7.8	5.5	6.9	8.0	5.9	7.3	8.0	6.1	7.4	6.9	5.9	7.0	6.6
40.0	4.5	5.7	6.6	4.5	5.8	6.8	4.9	6.2	7.2	5.1	6.5	6.7	4.9	6.3	6.4
42.0	3.6	4.7	5.5	3.6	4.8	5.6	4.0	5.2	6.1	4.2	5.5	6.4	4.0	5.3	6.2
44.0	2.8	3.8	4.4	2.8	3.9	4.6	3.2	4.3	5.1	3.4	4.6	5.4	3.2	4.4	5.3
46.0	2.1	3.0	3.5	2.1	3.1	3.7	2.5	3.5	4.2	2.7	3.8	4.5	2.5	3.6	4.4
48.0	1.5	2.2	2.6	1.5	2.3	2.9	1.8	2.8	3.4	2.1	3.0	3.7	2.9	3.9	3.6
50.0		1.5			1.7	2.1		2.1	2.6		2.3	3.0		2.2	2.9
θ(°)	36~ 83	38~ 84.5	44~ 84.5	42~ 83	45~ 84.5	48~ 84.5	47~ 83	50~ 84.5	53~ 84.5	51~ 83	54~ 84.5	57~ 84.5	56~ 83	57~ 84.5	60~ 84.5
標準フック	35t						35t								
フック重量	950kg						950kg								
標準巻掛本数	3						2								

カウンタウエイト 47t、アウトリガ張出幅 8.0m

ブーム+2.0m+23.5m油圧チルトジブ

単位:t

ブーム長さ(m) 作業半径 (m)	40.4			45.4			50.5			55.6			60.0		
	オフセット			オフセット			オフセット			オフセット			オフセット		
	0°	20°	40°	0°	20°	40°	0°	20°	40°	0°	20°	40°	0°	20°	40°
12.0	25.7														
14.0	23.9			22.1			17.6								
16.0	22.2			20.7			16.2			14.2					
18.0	20.8			19.3			15.0			13.1			12.4		
20.0	19.6	14.4		17.9			14.0			12.2			11.6		
22.0	18.5	13.6		16.7	13.8		13.1	10.3		11.4			10.8		
24.0	17.5	12.9		15.6	13.2		12.2	9.8		10.6	8.8		10.1		
26.0	15.2	12.3	9.3	14.7	12.6		11.4	9.4		10.0	8.3		9.5	8.0	
28.0	13.1	11.7	9.0	13.0	12.1	9.1	10.7	9.0		9.4	7.9		9.0	7.6	
30.0	11.4	11.2	8.7	11.3	11.5	8.9	10.1	8.6	7.5	8.9	7.6	6.7	8.5	7.2	
32.0	9.8	10.7	8.5	9.8	11.0	8.6	9.6	8.2	7.2	8.5	7.2	6.5	8.0	6.9	6.2
34.0	8.4	10.3	8.3	8.3	10.3	8.4	8.5	7.9	7.0	8.0	6.9	6.2	7.6	6.6	6.0
36.0	7.1	9.0	8.1	7.0	9.0	8.2	7.2	7.6	6.8	7.3	6.6	6.0	7.1	6.3	5.7
38.0	6.0	7.8	7.9	5.9	7.8	8.1	6.1	7.3	6.5	6.2	6.4	5.8	6.0	6.1	5.5
40.0	5.0	6.6	7.7	4.9	6.6	7.9	5.1	6.8	6.3	5.2	6.1	5.6	5.0	5.8	5.3
42.0	4.1	5.6	6.8	4.0	5.6	6.9	4.2	5.8	6.2	4.3	5.9	5.4	4.1	5.6	5.1
44.0	3.3	4.7	5.7	3.2	4.7	5.8	3.4	4.9	6.0	3.5	5.0	5.2	3.3	4.9	4.9
46.0	2.6	3.8	4.8	2.5	3.8	4.9	2.6	4.0	5.1	2.8	4.2	5.0	4.0	4.7	
48.0	1.9	3.0	3.8	1.8	3.1	4.0	2.0	3.3	4.3		3.4	4.5		3.3	4.4
50.0		2.3	3.0		2.3	3.2		2.6	3.5		2.7	3.7			3.6
54.0			1.5			1.7			2.0					2.3	
θ(°)	43~ 83	47~ 84.5	45~ 84.5	48~ 83	53~ 84.5	52~ 84.5	52~ 83	56~ 84.5	56~ 84.5	57~ 83	60~ 84.5	60~ 84.5	61~ 83	64~ 84.5	66~ 84.5
標準フック	35t						35t								
フック重量	950kg						950kg								
標準巻掛本数	3						2								

カウンタウエイト 47t、アウトリガ張出幅 8.0m

ブーム+2.0m+29.5m油圧チルトジブ

単位:t

ブーム長さ(m) 作業半径 (m)	40.4			45.4			50.5			55.6			60.0		
	オフセット			オフセット			オフセット			オフセット			オフセット		
	0°	20°	40°	0°	20°	40°	0°	20°	40°	0°	20°	40°	0°	20°	40°
14.0	20.4			18.9											
16.0	19.0			17.7			14.7								
18.0	17.8			16.7			13.6			12.4					
20.0	16.7			15.7			12.6			11.4			10.9		
22.0	15.8			14.9			11.7			10.6			10.1		
24.0	14.9	10.2		14.1	10.5		11.0			9.9			9.5		
26.0	14.1	9.6		13.4	9.9		10.3	8.2		9.3			8.9		
28.0	13.3	9.1		12.7	9.4		9.8	7.8		8.7	7.2		8.3		
30.0	11.5	8.7		11.4	9.0		9.2	7.4		8.2	6.8		7.9	6.5	
32.0	10.0	8.3	6.2	9.9	8.6	6.3	8.7	7.1		7.8	6.5		7.4	6.2	
34.0	8.6	7.9	6.0	8.5	8.2	6.1	8.2	6.8	5.9	7.4	6.2		7.0	5.9	
36.0	7.3	7.6	5.9	7.2	7.9	6.0	7.3	6.5	5.7	7.0	5.9	5.3	6.7	5.5	
38.0	6.2	7.2	5.7	6.0	7.5	5.8	6.1	6.3	5.5	6.5	5.7	5.1	6.2	5.2	4.4
40.0	5.2	6.9	5.5	5.0	7.2	5.6	5.1	6.0	5.3	5.5	5.4	4.9	5.2	4.9	4.2
42.0	4.3	6.2	5.4	4.1	6.2	5.5	4.2	5.8	5.1	4.6	5.2	4.7	4.3	4.6	4.0
44.0	3.5	5.3	5.3	3.3	5.2	5.4	3.4	5.3	5.0	3.8	5.0	4.5	3.5	4.3	3.8
46.0	2.7	4.4	5.1	2.6	4.3	5.2	2.7	4.4	4.8	3.0	4.8	4.3	4.1	4.1	3.6
48.0	2.1	3.6	4.8		3.5	4.9		3.7	4.7		4.0	4.2		3.8	3.4
50.0	1.5	2.9	4.0		2.8	4.0		2.9	4.2		3.3	4.1		3.1	3.3
54.0		1.6	2.4			2.5			2.7			3.1			3.0
θ(°)	46~ 83	50~ 84.5	55~ 84.5	54~ 83	58~ 84.5	60~ 84.5	57~ 83	61~ 84.5	63~ 84.5	60~ 83	64~ 84.5	66~ 84.5	64~ 83	66~ 84.5	68~ 84.5
標準フック	35t												12.2t		
フック重量	950kg												440kg		
標準巻掛本数	2												1		

カウンタウエイト 47t、アウトリガ張出幅 8.0m

ブーム+2.0m+35.5m油圧チルトジブ

単位:t

ブーム長さ(m) 作業半径 (m)	40.4			45.4			50.5			55.6			60.0		
	オフセット			オフセット			オフセット			オフセット			オフセット		
	0°	20°	40°	0°	20°	40°	0°	20°	40°	0°	20°	40°	0°	20°	40°
14.0	17.2														
16.0	16.2			15.1											
18.0	15.3			14.3			12.9								
20.0	14.5			13.6			12.0			10.6					
22.0	13.7			12.9			11.1			9.8			9.4		
24.0	12.8			12.3			10.4			9.2			8.7		
26.0	12.0	7.9		11.7			9.8			8.6			8.2		
28.0	11.3	7.5		11.1	7.7		9.2			8.0			7.7		
30.0	10.7	7.1		10.6	7.3		8.7	6.8		7.5			7.2		
32.0	10.1	6.7		10.1	6.9		8.2	6.5		7.1	5.8		6.8	5.4	
34.0	8.9	6.4		8.7	6.6		7.8	6.2		6.7	5.6		6.4	5.0	
36.0	7.7	6.1	4.5	7.4	6.3		7.4	5.9		6.4	5.3		6.1	4.7	
38.0	6.5	5.8	4.3	6.3	6.0	4.4	6.6	5.7		6.0	5.0		5.8	4.4	
40.0	5.5	5.5	4.2	5.3	5.7	4.2	5.6	5.5	4.5	5.7	4.8		5.3	4.1	
42.0	4.6	5.3	4.0	4.4	5.5	4.1	4.7	5.2	4.4	4.7	4.6	4.1	4.5	3.9	3.3
44.0	3.8	5.0	3.9	3.6	5.3	4.0	3.9	5.0	4.3	3.9	4.4	3.9	4.4	3.9	3.1
46.0	3.0	4.8	3.8	2.8	4.9	3.9	3.1	4.8	4.1	3.2	4.2	3.7	4.4	3.4	2.9
48.0	2.4	4.2	3.7		4.1	3.7		4.5	4.0		4.0	3.5		3.2	2.7
50.0		3.5	3.6		3.4	3.7		3.7	3.9		3.8	3.3		3.0	2.6
54.0		2.2	3.4			3.4			3.7			3.0			2.3
58.0			2.1												
θ(°)	53~ 83	56~ 84.5	58~ 84.5	58~ 83	63~ 84.5	66~ 84.5	60~ 83	66~ 84.5	69~ 84.5	63~ 83	68~ 84.5	72~ 84.5	67~ 83	70~ 84.5	73~ 84.5
標準フック	35t												12.2t		
フック重量	950kg												440kg		
標準巻掛本数	2												1		

油圧チルトジブ

カウンタウエイト 47t、アウトリガ張出幅 6.8m

ブーム+2.0m+3.5m油圧チルトジブ

単位:t

ブーム長さ(m) 作業半径 (m)	40.4			45.4			50.5			55.6			60.0		
	オフセット			オフセット			オフセット			オフセット			オフセット		
	0°	20°	40°	0°	20°	40°	0°	20°	40°	0°	20°	40°	0°	20°	40°
8.0	47.7														
9.0	44.9	42.5		38.0											
10.0	42.5	40.3	38.9	36.1	33.9			28.4							
11.0	40.3	38.4	37.1	34.4	32.4	31.1	27.0	25.5		23.9					
12.0	38.3	36.6	35.5	32.9	31.1	29.9	25.7	24.4	23.5	22.8	21.5				
14.0	34.6	33.6	32.7	30.3	28.8	27.8	23.6	22.5	21.7	20.8	19.9	19.2	19.7		
16.0	27.4	28.1	28.7	27.7	26.8	26.0	21.8	20.9	20.3	19.2	18.5	18.0	18.2	17.5	17.1
18.0	22.1	22.8	23.2	22.4	23.1	23.5	20.3	19.5	19.0	17.8	17.2	16.8	16.9	16.3	15.9
20.0	18.1	18.7	19.0	18.5	19.0	19.4	19.0	18.3	17.9	16.6	16.1	15.8	15.7	15.2	14.9
22.0	15.0	15.5	15.8	15.3	15.8	16.1	16.0	16.4	16.7	15.6	15.1	14.8	14.7	14.3	14.1
24.0	12.5	12.9	13.1	12.8	13.2	13.5	13.4	13.8	14.1	14.0	14.3	14.0	13.9	13.5	13.3
26.0	10.3	10.7	11.0	10.7	11.1	11.3	11.4	11.7	11.9	11.9	12.3	12.5	12.0	12.4	12.6
28.0	8.4	8.7	8.9	8.7	9.1	9.3	9.5	9.9	10.1	10.2	10.5	10.7	10.3	10.6	10.8
30.0	6.7	7.0	7.2	7.1	7.4	7.6	7.8	8.2	8.4	8.5	8.8	9.1	8.6	8.9	9.2
32.0	5.3	5.5	5.6	5.6	5.9	6.1	6.4	6.7	6.9	7.0	7.4	7.5	7.1	7.4	7.7
34.0	4.1	4.3	4.3	4.4	4.7	4.8	5.1	5.4	5.5	5.8	6.1	6.2	5.9	6.2	6.3
36.0	3.0	3.2		3.3	3.6	3.6	4.0	4.3	4.4	4.7	4.9	5.1	4.8	5.0	5.2
38.0				2.4	2.6	2.6	3.1	3.3	3.4	3.7	3.9	4.0	3.8	4.0	4.1
40.0							2.2	2.4	2.5	2.9	3.1	3.1	2.9	3.1	3.2
42.0							1.5	1.6	1.7	2.1	2.3	2.3	2.1	2.3	2.4
44.0											1.5	1.6			1.7
θ(°)	37~ 84.5	38~ 84.5	43~ 84.5	41~ 84.5	42~ 84.5	42~ 84.5	41~ 84.5	42~ 84.5	42~ 84.5	47~ 84.5	45~ 84.5	45~ 84.5	51~ 84.5	52~ 84.5	50~ 84.5
標準フック	80t			80t			35t			35t					
フック重量	1550kg			1550kg			950kg			950kg					
標準巻掛本数	5			4			3			3					

カウンタウエイト 47t、アウトリガ張出幅 6.8m

ブーム+2.0m+11.5m油圧チルトジブ

単位:t

ブーム長さ(m) 作業半径 (m)	40.4			45.4			50.5			55.6			60.0		
	オフセット			オフセット			オフセット			オフセット			オフセット		
	0°	20°	40°	0°	20°	40°	0°	20°	40°	0°	20°	40°	0°	20°	40°
10.0	38.8														
11.0	36.7			31.1											
12.0	34.8			29.6			23.3								
14.0	31.5	27.6		27.0	23.4		21.2			18.8					
16.0	28.1	26.1	22.7	24.8	21.8		19.4	16.7		17.4	14.9		15.6		
18.0	22.9	24.2	21.8	23.0	20.4	18.8	18.0	15.8	14.0	16.0	14.0		15.1		
20.0	18.9	20.8	21.0	19.1	19.2	17.8	16.7	15.0	13.4	14.9	13.2	12.0	14.0	12.5	
22.0	15.7	17.4	18.8	16.0	17.7	16.9	15.6	14.1	12.8	13.9	12.5	11.4	13.1	11.9	
24.0	13.2	14.7	15.9	13.5	14.9	16.1	13.8	13.3	12.3	13.0	11.9	10.9	12.3	11.3	10.4
26.0	11.2	12.4	13.5	11.4	12.7	13.7	11.7	12.6	11.9	12.1	11.3	10.5	11.5	10.7	9.9
28.0	9.2	10.6	11.5	9.5	10.8	11.7	9.9	11.1	11.4	10.4	10.8	10.0	10.3	10.2	9.5
30.0	7.6	8.9	9.8	7.9	9.2	10.0	8.2	9.5	10.4	8.8	9.9	9.7	8.6	9.7	9.2
32.0	6.2	7.3	8.2	6.4	7.6	8.5	6.8	8.0	8.9	7.3	8.5	9.3	7.2	8.4	8.8
34.0	4.9	6.0	6.7	5.2	6.3	7.1	5.6	6.7	7.5	6.1	7.2	8.0	5.9	7.0	7.9
36.0	3.9	4.8	5.4	4.1	5.1	5.8	4.5	5.5	6.2	5.0	6.0	6.7	4.8	5.8	6.6
38.0	2.9	3.7	4.2	3.1	4.0	4.6	3.5	4.4	5.1	4.0	4.9	5.6	3.8	4.8	5.5
40.0		2.8	3.2	2.3	3.1	3.6	2.7	3.5	4.0	3.1	4.0	4.6	3.0	3.8	4.5
42.0				1.5	2.2	2.7	1.9	2.6	3.1	2.3	3.1	3.7	3.0	3.6	4.1
44.0					1.5	1.8		1.9	2.3		2.4	2.8			2.8
46.0									1.6			2.1			
θ(°)	44~ 83	45~ 84.5	48~ 84.5	44~ 83	45~ 84.5	47~ 84.5	49~ 83	50~ 84.5	49~ 84.5	53~ 83	54~ 84.5	54~ 84.5	58~ 83	60~ 84.5	60~ 84.5
標準フック	80t			80t			35t			35t					
フック重量	1550kg			1550kg			950kg			950kg					
標準巻掛本数	4			4			3			3					

カウンタウエイト 47t、アウトリガ張出幅 6.8m

ブーム+2.0m+17.5m油圧チルトジブ

単位:t

ブーム長さ(m)	40.4			45.4			50.5			55.6			60.0		
	オフセット			オフセット			オフセット			オフセット			オフセット		
作業半径(m)	0°	20°	40°	0°	20°	40°	0°	20°	40°	0°	20°	40°	0°	20°	40°
11.0	31.5														
12.0	30.3			27.0											
14.0	28.1			24.6					19.5						
16.0	26.3	20.6		22.6					17.9			15.6			14.8
18.0	23.5	19.5		20.8	17.9				16.5	13.4		14.5			13.7
20.0	19.5	18.6		19.4	16.8				15.3	12.7		13.5	11.3		12.8
22.0	16.4	17.8	14.0	16.4	15.8				14.3	12.0		12.6	10.7		12.0 10.2
24.0	13.8	16.0	13.6	13.8	15.0	13.7			13.4	11.5	10.1	11.9	10.1		11.2 9.6
26.0	11.7	13.6	13.3	11.7	13.7	13.1	12.1		11.0	9.7	11.1	9.6	8.7	10.5	9.2 8.3
28.0	9.9	11.7	12.9	9.9	11.7	12.5	10.3	10.5	9.3	10.5	9.2	8.3	9.9	8.7	7.9
30.0	8.2	10.0	11.3	8.2	10.1	11.4	8.7	10.1	9.0	8.9	8.8	8.0	8.7	8.4	7.6
32.0	6.8	8.6	9.7	6.8	8.6	9.8	7.2	9.0	8.7	7.5	8.4	7.7	7.2	8.0	7.3
34.0	5.5	7.1	8.4	5.5	7.2	8.5	6.0	7.6	8.5	6.2	7.9	7.4	6.0	7.7	7.1
36.0	4.4	5.9	7.0	4.4	6.0	7.2	4.9	6.4	7.6	5.1	6.6	7.1	4.9	6.5	6.8
38.0	3.5	4.8	5.8	3.5	4.9	5.9	3.9	5.3	6.4	4.1	5.5	6.6	3.9	5.4	6.5
40.0	2.6	3.8	4.7	2.6	3.9	4.8	3.0	4.3	5.3	3.2	4.5	5.6	3.0	4.4	5.5
42.0	1.9	2.9	3.7	1.8	3.0	3.8	2.2	3.4	4.3	2.5	3.7	4.6		3.5	4.5
44.0		2.1	2.7		2.2	2.9		2.6	3.4		2.9	3.7			3.6
46.0			1.9			2.1			2.6			2.9			2.8
θ(°)	45~83	48~84.5	48~84.5	50~83	53~84.5	54~84.5	54~83	57~84.5	58~84.5	57~83	60~84.5	62~84.5	61~83	64~84.5	64~84.5
標準フック	35t						35t								
フック重量	950kg						950kg								
標準巻掛本数	3						2								

カウンタウエイト 47t、アウトリガ張出幅 6.8m

ブーム+2.0m+23.5m油圧チルトジブ

単位:t

ブーム長さ(m)	40.4			45.4			50.5			55.6			60.0		
	オフセット			オフセット			オフセット			オフセット			オフセット		
作業半径(m)	0°	20°	40°	0°	20°	40°	0°	20°	40°	0°	20°	40°	0°	20°	40°
12.0	25.7														
14.0	23.9			22.1					17.6						
16.0	22.2			20.7					16.2			14.2			
18.0	20.8			19.3					15.0			13.1			12.4
20.0	19.6	14.4		17.9					14.0			12.2			11.6
22.0	16.9	13.6		16.7	13.8				13.1	10.3		11.4			10.8
24.0	14.3	12.9		14.2	13.2				12.2	9.8		10.6	8.8		10.1
26.0	12.2	12.3	9.3	12.1	12.6				11.4	9.4		10.0	8.3	9.5	8.0
28.0	10.4	11.7	9.0	10.4	12.1	9.1	10.5	9.0			9.4	7.9		9.0	7.6
30.0	8.8	10.9	8.7	8.7	10.9	8.9	8.9	8.6	7.5	8.9	7.6	6.7		8.5	7.2
32.0	7.3	9.5	8.5	7.2	9.4	8.6	7.4	8.2	7.2	7.6	7.2	6.5	7.3	6.9	6.2
34.0	6.0	8.2	8.3	6.0	8.2	8.4	6.1	7.9	7.0	6.3	6.9	6.2	6.0	6.6	6.0
36.0	4.9	6.9	8.1	4.8	6.9	8.2	5.0	7.0	6.8	5.2	6.6	6.0	4.9	6.3	5.7
38.0	3.9	5.7	7.2	3.9	5.7	7.3	4.0	5.9	6.5	4.2	6.1	5.8	3.9	5.9	5.5
40.0	3.1	4.7	6.0	3.0	4.7	6.1	3.2	4.9	6.3	3.3	5.0	5.6		4.9	5.3
42.0	2.3	3.8	5.0	2.2	3.8	5.1		4.0	5.3		4.1	5.4		4.0	5.1
44.0		2.9	4.0		3.0	4.1		3.2	4.3		3.3	4.5			4.4
46.0		2.2	3.1		2.2	3.2			3.5			3.7			3.6
48.0			2.3			2.4			2.7			2.9			
θ(°)	51~83	53~84.5	55~84.5	55~83	57~84.5	60~84.5	59~83	62~84.5	63~84.5	62~83	65~84.5	66~84.5	66~83	69~84.5	70~84.5
標準フック	35t						35t								
フック重量	950kg						950kg								
標準巻掛本数	3						2								

油圧チルトジブ

カウンタウエイト 47t、アウトリガ張出幅 6.8m

ブーム+2.0m+29.5m油圧チルトジブ

単位:t

ブーム長さ(m) 作業半径 (m)	40.4			45.4			50.5			55.6			60.0		
	オフセット			オフセット			オフセット			オフセット			オフセット		
	0°	20°	40°	0°	20°	40°	0°	20°	40°	0°	20°	40°	0°	20°	40°
14.0	20.4			18.9											
16.0	19.0			17.7			14.7								
18.0	17.8			16.7			13.6			12.4					
20.0	16.7			15.7			12.6			11.4			10.9		
22.0	15.8			14.9			11.7			10.6			10.1		
24.0	14.5	10.2		14.1	10.5		11.0			9.9			9.5		
26.0	12.4	9.6		12.3	9.9		10.3	8.2		9.3			8.9		
28.0	10.6	9.1		10.5	9.4		9.8	7.8		8.7	7.2		8.3		
30.0	9.0	8.7		8.8	9.0		8.9	7.4		8.2	6.8		7.9	6.5	
32.0	7.5	8.3	6.2	7.4	8.6	6.3	7.5	7.1		7.8	6.5		7.4	6.2	
34.0	6.2	7.9	6.0	6.1	8.2	6.1	6.2	6.8	5.9	6.6	6.2		6.3	5.9	
36.0	5.1	7.6	5.9	5.0	7.5	6.0	5.1	6.5	5.7	5.5	5.9	5.3	5.2	5.5	
38.0	4.1	6.4	5.7	4.0	6.3	5.8	4.1	6.3	5.5	4.5	5.7	5.1	4.2	5.2	4.4
40.0	3.3	5.3	5.5	3.1	5.3	5.6	3.2	5.4	5.3	3.6	5.4	4.9	4.9	4.9	4.2
42.0	2.5	4.4	5.4		4.3	5.5		4.4	5.1		4.8	4.7		4.6	4.0
44.0		3.5	5.0		3.5	5.0		3.6	5.0		3.9	4.5			3.8
46.0		2.7	4.1		2.7	4.1			4.3			4.3			3.6
48.0			3.3			3.3			3.5			3.9			3.4
50.0			2.5			2.5									
θ (°)	55~ 83	59~ 84.5	61~ 84.5	60~ 83	62~ 84.5	64~ 84.5	62~ 83	67~ 84.5	69~ 84.5	65~ 83	69~ 84.5	72~ 84.5	68~ 83	72~ 84.5	73~ 84.5
標準フック	35t														
フック重量	950kg														
標準巻掛本数	2														
													12.2t		
													440kg		
													1		

カウンタウエイト 25t、アウトリガ張出幅 8.5m

ブーム+2.0m+3.5m油圧チルトジブ

単位:t

ブーム長さ(m) 作業半径 (m)	40.4			45.4			50.5			55.6			60.0		
	オフセット			オフセット			オフセット			オフセット			オフセット		
	0°	20°	40°	0°	20°	40°	0°	20°	40°	0°	20°	40°	0°	20°	40°
8.0	47.7														
9.0	44.9	42.5		38.0											
10.0	42.5	40.3	38.9	36.1	33.9			28.4							
11.0	40.3	38.4	37.1	34.4	32.4	31.1	27.0	25.5		23.9					
12.0	38.3	36.6	35.5	32.9	31.1	29.9	25.7	24.4	23.5	22.8	21.5				
14.0	31.1	32.1	32.7	30.3	28.8	27.8	23.6	22.5	21.7	20.8	19.9	19.2	19.7		
16.0	23.9	24.7	25.3	24.3	25.1	25.7	21.8	20.9	20.3	19.2	18.5	18.0	18.2	17.5	17.1
18.0	18.8	19.5	20.0	19.2	19.9	20.3	19.9	19.5	19.0	17.8	17.2	16.8	16.9	16.3	15.9
20.0	15.1	15.6	16.0	15.4	16.0	16.4	16.1	16.7	17.0	16.6	16.1	15.8	15.7	15.2	14.9
22.0	12.1	12.6	12.9	12.5	13.0	13.3	13.1	13.6	14.0	13.7	14.2	14.6	13.9	14.3	14.1
24.0	9.7	10.2	10.5	10.1	10.5	10.8	10.8	11.2	11.5	11.4	11.8	12.1	11.5	11.9	12.2
26.0	7.5	8.0	8.2	7.9	8.4	8.7	8.7	9.2	9.5	9.4	9.8	10.0	9.5	9.9	10.2
28.0	5.8	6.1	6.3	6.1	6.5	6.8	6.9	7.3	7.6	7.6	8.0	8.3	7.7	8.1	8.4
30.0	4.2	4.6	4.7	4.6	5.0	5.2	5.4	5.8	6.0	6.1	6.5	6.7	6.2	6.6	6.8
32.0	3.0	3.2	3.3	3.3	3.6	3.8	4.1	4.4	4.6	4.8	5.1	5.3	4.9	5.2	5.4
34.0					2.5	2.6	3.0	3.3	3.4	3.6	3.9	4.1	3.7	4.0	4.2
36.0								2.2	2.4	2.6	2.9	3.0		3.0	3.1
θ(°)	45~ 84.5	46~ 84.5	47~ 84.5	51~ 84.5	49~ 84.5	50~ 84.5	53~ 84.5	51~ 84.5	52~ 84.5	55~ 84.5	56~ 84.5	56~ 84.5	60~ 84.5	59~ 84.5	59~ 84.5
標準フック	80t						35t								
フック重量	1550kg			1550kg			950kg								
標準巻掛本数	5			4			3								

カウンタウエイト 25t、アウトリガ張出幅 8.5m

ブーム+2.0m+11.5m油圧チルトジブ

単位:t

ブーム長さ(m) 作業半径 (m)	40.4			45.4			50.5			55.6			60.0		
	オフセット			オフセット			オフセット			オフセット			オフセット		
	0°	20°	40°	0°	20°	40°	0°	20°	40°	0°	20°	40°	0°	20°	40°
10.0	38.8														
11.0	36.7			31.1											
12.0	34.8			29.6			23.3								
14.0	31.5	27.6		27.0	23.4		21.2			18.8					
16.0	24.8	26.1	22.7	24.8	21.8		19.4	16.7		17.4	14.9		15.6		
18.0	19.7	22.0	21.8	20.0	20.4	18.8	18.0	15.8	14.0	16.0	14.0		15.1		
20.0	15.9	17.9	19.6	16.2	18.2	17.8	16.5	15.0	13.4	14.9	13.2	12.0	14.0	12.5	
22.0	12.9	14.7	16.1	13.2	14.9	16.4	13.6	14.1	12.8	13.9	12.5	11.4	13.1	11.9	
24.0	10.6	12.1	13.4	10.9	12.4	13.6	11.2	12.7	12.3	11.7	11.9	10.9	11.5	11.3	10.4
26.0	8.5	10.0	11.1	8.8	10.3	11.4	9.2	10.6	11.7	9.7	11.0	10.5	9.6	10.7	9.9
28.0	6.7	8.2	9.2	7.0	8.5	9.5	7.4	8.9	9.8	7.9	9.3	10.0	7.8	9.2	9.5
30.0	5.2	6.6	7.6	5.5	6.9	7.9	5.9	7.3	8.2	6.4	7.8	8.7	6.2	7.6	8.6
32.0	3.9	5.1	6.0	4.2	5.4	6.3	4.6	5.8	6.8	5.1	6.3	7.3	4.9	6.2	7.2
34.0	2.8	3.9	4.6	3.1	4.2	5.0	3.4	4.6	5.4	4.0	5.1	5.9	3.8	4.9	5.8
36.0		2.8	3.4		3.1	3.8		3.5	4.2		4.0	4.8		3.9	4.7
38.0						2.7			3.2		3.0	3.7			3.6
40.0												2.8			
θ(°)	50~ 83	52~ 84.5	55~ 84.5	55~ 83	56~ 84.5	56~ 84.5	58~ 83	60~ 84.5	60~ 84.5	61~ 83	61~ 84.5	61~ 84.5	64~ 83	65~ 84.5	66~ 84.5
標準フック	80t						35t								
フック重量	1550kg						950kg								
標準巻掛本数	4						3								

油圧チルトジブ

カウンタウエイト 25t、アウトリガ張出幅 8.5m

ブーム+2.0m+17.5m油圧チルトジブ

単位:t

ブーム長さ(m) 作業半径 (m)	40.4			45.4			50.5			55.6			60.0		
	オフセット			オフセット			オフセット			オフセット			オフセット		
	0°	20°	40°	0°	20°	40°	0°	20°	40°	0°	20°	40°	0°	20°	40°
11.0	31.5														
12.0	30.3			27.0											
14.0	28.1			24.6			19.5								
16.0	25.6	20.6		22.6			17.9			15.6			14.8		
18.0	20.5	19.5		20.5	17.9		16.5	13.4		14.5			13.7		
20.0	16.6	18.6		16.6	16.8		15.3	12.7		13.5	11.3		12.8		
22.0	13.6	16.2	14.0	13.6	15.8		14.0	12.0		12.6	10.7		12.0	10.2	
24.0	11.2	13.5	13.6	11.2	13.5	13.7	11.6	11.5	10.1	11.9	10.1		11.2	9.6	
26.0	9.3	11.3	13.0	9.3	11.3	13.1	9.7	11.0	9.7	9.9	9.6	8.7	9.7	9.2	8.3
28.0	7.4	9.5	11.0	7.4	9.5	11.0	7.9	9.9	9.3	8.1	9.2	8.3	7.9	8.7	7.9
30.0	5.9	7.9	9.3	5.9	8.0	9.3	6.4	8.3	9.0	6.6	8.5	8.0	6.4	8.4	7.6
32.0	4.6	6.4	7.8	4.6	6.5	7.9	5.0	6.9	8.2	5.3	7.1	7.7	5.0	7.0	7.3
34.0	3.4	5.1	6.4	3.4	5.2	6.5	3.9	5.6	7.0	4.1	5.8	7.2		5.7	7.1
36.0	2.5	3.9	5.1		4.0	5.2		4.4	5.7		4.7	5.9		4.5	5.8
38.0		2.9	3.9		3.0	4.1		3.4	4.6		3.7	4.8			4.7
40.0			2.9			3.1			3.5			3.8			
θ(°)	53~ 83	57~ 84.5	58~ 84.5	59~ 83	60~ 84.5	62~ 84.5	62~ 83	63~ 84.5	65~ 84.5	64~ 83	66~ 84.5	68~ 84.5	68~ 83	69~ 84.5	71~ 84.5
標準フック	35t						35t								
フック重量	950kg						950kg								
標準巻掛本数	3						2								

カウンタウエイト 25t、アウトリガ張出幅 8.5m

ブーム+2.0m+23.5m油圧チルトジブ

単位:t

ブーム長さ(m) 作業半径 (m)	40.4			45.4			50.5			55.6			60.0		
	オフセット			オフセット			オフセット			オフセット			オフセット		
	0°	20°	40°	0°	20°	40°	0°	20°	40°	0°	20°	40°	0°	20°	40°
12.0	25.7														
14.0	23.9			22.1			17.6								
16.0	22.2			20.7			16.2			14.2					
18.0	20.8			19.3			15.0			13.1			12.4		
20.0	17.2	14.4		17.1			14.0			12.2			11.6		
22.0	14.2	13.6		14.1	13.8		13.1	10.3		11.4			10.8		
24.0	11.8	12.9		11.7	13.2		11.9	9.8		10.6	8.8		10.1		
26.0	9.8	12.3	9.3	9.7	12.4		9.9	9.4		10.0	8.3		9.5	8.0	
28.0	8.0	10.5	9.0	8.0	10.5	9.1	8.1	9.0		8.3	7.9		8.0	7.6	
30.0	6.5	8.9	8.7	6.4	8.9	8.9	6.6	8.6	7.5	6.7	7.6	6.7	6.5	7.2	
32.0	5.1	7.5	8.5	5.1	7.5	8.6	5.2	7.6	7.2	5.4	7.2	6.5	5.1	6.9	6.2
34.0	4.0	6.2	7.8	3.9	6.1	7.8	4.1	6.3	7.0		6.5	6.2		6.3	6.0
36.0	3.0	5.0	6.6		5.0	6.7		5.1	6.8		5.3	6.0		5.1	5.7
38.0		3.9	5.4		3.9	5.5		4.1	5.7		4.2	5.8			5.5
40.0		3.0	4.3			4.4			4.6			4.8			4.7
42.0			3.3			3.4			3.6			3.8			
44.0			2.4												
θ(°)	57~ 83	60~ 84.5	60~ 84.5	62~ 83	66~ 84.5	66~ 84.5	65~ 83	68~ 84.5	69~ 84.5	68~ 83	70~ 84.5	71~ 84.5	70~ 83	73~ 84.5	75~ 84.5
標準フック	35t						35t								
フック重量	950kg						950kg								
標準巻掛本数	3						2								

カウンタウエイト 25t、アウトリガ張出幅 8.0m

ブーム+2.0m+3.5m油圧チルトジブ

単位:t

ブーム長さ(m) 作業半径 (m)	40.4			45.4			50.5			55.6			60.0					
	オフセット			オフセット			オフセット			オフセット			オフセット					
	0°	20°	40°	0°	20°	40°	0°	20°	40°	0°	20°	40°	0°	20°	40°			
8.0	47.7																	
9.0	44.9	42.5		38.0														
10.0	42.5	40.3	38.9	36.1	33.9		28.4											
11.0	40.3	38.4	37.1	34.4	32.4	31.1	27.0	25.5		23.9								
12.0	38.2	36.6	35.5	32.9	31.1	29.9	25.7	24.4	23.5	22.8	21.5							
14.0	28.4	29.3	30.1	28.7	28.8	27.8	23.6	22.5	21.7	20.8	19.9	19.2	19.7					
16.0	21.8	22.6	23.2	22.1	22.9	23.5	21.8	20.9	20.3	19.2	18.5	18.0	18.2	17.5	17.1			
18.0	17.1	17.8	18.2	17.5	18.1	18.6	18.2	18.8	19.0	17.8	17.2	16.8	16.9	16.3	15.9			
20.0	13.6	14.2	14.5	13.9	14.5	14.9	14.6	15.2	15.6	15.2	15.8	15.8	15.4	15.2	14.9			
22.0	10.9	11.4	11.7	11.2	11.7	12.0	11.9	12.3	12.7	12.5	12.9	13.3	12.6	13.1	13.4			
24.0	8.5	9.0	9.3	8.8	9.4	9.7	9.7	10.1	10.4	10.3	10.7	10.9	10.4	10.8	11.1			
26.0	6.4	6.9	7.1	6.8	7.3	7.6	7.6	8.1	8.4	8.3	8.8	9.0	8.4	8.9	9.2			
28.0	4.8	5.1	5.3	5.1	5.5	5.8	5.9	6.3	6.6	6.6	7.0	7.3	6.7	7.1	7.4			
30.0	3.3	3.7	3.8	3.7	4.1	4.3	4.5	4.8	5.1	5.2	5.5	5.8	5.3	5.6	5.9			
32.0		2.4	2.5			3.0	3.3	3.6	3.8	3.9	4.3	4.4	4.0	4.3	4.6			
34.0								2.5	2.6	2.9	3.1	3.3		3.2	3.4			
θ(°)	49~ 84.5	46~ 84.5	47~ 84.5	54~ 84.5	55~ 84.5	53~ 84.5	56~ 84.5	54~ 84.5	55~ 84.5	57~ 84.5	58~ 84.5	58~ 84.5	62~ 84.5	61~ 84.5	62~ 84.5			
標準フック	80t						35t											
フック重量	1550kg						950kg											
標準巻掛本数	5						4						3					

カウンタウエイト 25t、アウトリガ張出幅 8.0m

ブーム+2.0m+11.5m油圧チルトジブ

単位:t

ブーム長さ(m) 作業半径 (m)	40.4			45.4			50.5			55.6			60.0		
	オフセット			オフセット			オフセット			オフセット			オフセット		
	0°	20°	40°	0°	20°	40°	0°	20°	40°	0°	20°	40°	0°	20°	40°
10.0	38.8														
11.0	36.7			31.1											
12.0	34.8			29.6			23.3								
14.0	29.2	27.6		27.0	23.4		21.2			18.8					
16.0	22.6	25.3	22.7	22.9	21.8		19.4	16.7		17.4	14.9		15.6		
18.0	17.9	20.2	21.8	18.2	20.4	18.8	18.0	15.8	14.0	16.0	14.0		15.1		
20.0	14.4	16.4	18.0	14.7	16.6	17.8	15.0	15.0	13.4	14.9	13.2	12.0	14.0	12.5	
22.0	11.7	13.4	14.8	11.9	13.6	15.1	12.3	13.9	12.8	12.7	12.5	11.4	12.6	11.9	
24.0	9.4	11.0	12.2	9.7	11.2	12.5	10.1	11.6	12.3	10.5	11.9	10.9	10.4	11.3	10.4
26.0	7.4	9.0	10.1	7.7	9.3	10.4	8.1	9.6	10.7	8.6	10.0	10.5	8.5	9.9	9.9
28.0	5.7	7.2	8.3	6.0	7.5	8.6	6.4	7.9	8.9	6.9	8.4	9.3	6.8	8.3	9.2
30.0	4.3	5.6	6.6	4.6	5.9	7.0	5.0	6.3	7.4	5.5	6.8	7.8	5.3	6.7	7.8
32.0	3.1	4.3	5.1	3.3	4.6	5.5	3.7	5.0	5.9	4.2	5.5	6.4	4.1	5.3	6.3
34.0		3.1	3.8		3.4	4.2		3.8	4.6		4.3	5.1		4.2	5.0
36.0					3.0			3.5			3.2	4.0			3.9
θ(°)	53~ 83	55~ 84.5	58~ 84.5	57~ 83	59~ 84.5	59~ 84.5	60~ 83	62~ 84.5	62~ 84.5	63~ 84.5	63~ 83	65~ 84.5	65~ 83	67~ 84.5	68~ 84.5
標準フック	80t						35t								
フック重量	1550kg						950kg								
標準巻掛本数	4						3								

油圧チルトジブ

カウンタウエイト 25t、アウトリガ張出幅 8.0m

ブーム+2.0m+17.5m油圧チルトジブ

単位:t

ブーム長さ(m) 作業半径 (m)	40.4			45.4			50.5			55.6			60.0		
	オフセット			オフセット			オフセット			オフセット			オフセット		
	0°	20°	40°	0°	20°	40°	0°	20°	40°	0°	20°	40°	0°	20°	40°
11.0	31.5														
12.0	30.3			27.0											
14.0	28.1			24.6			19.5								
16.0	23.4	20.6		22.6			17.9			15.6			14.8		
18.0	18.7	19.5		18.7	17.9		16.5	13.4		14.5			13.7		
20.0	15.1	18.0		15.1	16.8		15.3	12.7		13.5	11.3		12.8		
22.0	12.3	14.8	14.0	12.3	14.8		12.7	12.0		12.6	10.7		12.0	10.2	
24.0	10.1	12.3	13.6	10.1	12.3	13.7	10.5	11.5	10.1	10.7	10.1		10.5	9.6	
26.0	8.1	10.3	11.9	8.1	10.3	12.0	8.6	10.7	9.7	8.8	9.6	8.7	8.6	9.2	8.3
28.0	6.4	8.5	10.0	6.4	8.6	10.1	6.9	8.9	9.3	7.1	9.1	8.3	6.9	8.7	7.9
30.0	5.0	7.0	8.4	5.0	7.0	8.5	5.4	7.4	8.8	5.7	7.7	8.0	5.4	7.5	7.6
32.0	3.7	5.5	7.0	3.7	5.6	7.1	4.2	6.0	7.4	4.4	6.2	7.6		6.1	7.3
34.0	2.7	4.3	5.6		4.3	5.7		4.8	6.2		5.0	6.4		4.8	6.3
36.0		3.2	4.4		3.3	4.5		3.7	4.9		3.9	5.2			5.1
38.0			3.2		3.4	4.5		3.8	4.8		4.1	5.4			
θ(°)	56~83	59~84.5	61~84.5	61~83	62~84.5	64~84.5	64~83	65~84.5	67~84.5	66~83	68~84.5	69~84.5	70~83	71~84.5	73~84.5
標準フック	35t						35t								
フック重量	950kg						950kg								
標準巻掛本数	3						2								

カウンタウエイト 25t、アウトリガ張出幅 8.0m

ブーム+2.0m+23.5m油圧チルトジブ

単位:t

ブーム長さ(m) 作業半径 (m)	40.4			45.4			50.5			55.6			60.0		
	オフセット			オフセット			オフセット			オフセット			オフセット		
	0°	20°	40°	0°	20°	40°	0°	20°	40°	0°	20°	40°	0°	20°	40°
12.0	25.7														
14.0	23.9			22.1			17.6								
16.0	22.2			20.7			16.2			14.2					
18.0	19.3			19.2			15.0			13.1			12.4		
20.0	15.7	14.4		15.6			14.0			12.2			11.6		
22.0	12.9	13.6		12.8	13.8		13.0	10.3		11.4			10.8		
24.0	10.6	12.9		10.6	13.2		10.7	9.8		10.6	8.8		10.1		
26.0	8.7	11.3	9.3	8.6	11.3		8.8	9.4		9.0	8.3		8.7	8.0	
28.0	7.0	9.5	9.0	6.9	9.5	9.1	7.1	9.0		7.2	7.9		7.0	7.6	
30.0	5.5	8.0	8.7	5.4	8.0	8.9	5.6	8.1	7.5	5.8	7.6	6.7		7.2	
32.0	4.3	6.6	8.4	4.2	6.6	8.4	4.4	6.8	7.2		6.9	6.5		6.7	6.2
34.0	3.2	5.3	7.1		5.3	7.1		5.5	7.0		5.6	6.2		5.5	6.0
36.0		4.2	5.9		4.2	5.9		4.4	6.1		4.5	6.0			5.7
38.0		3.2	4.7			4.8			5.0			5.1			5.0
40.0			3.6			3.7			3.9			4.1			
42.0			2.7												
θ(°)	59~83	62~84.5	63~84.5	64~83	68~84.5	69~84.5	66~83	69~84.5	71~84.5	70~83	72~84.5	73~84.5	73~83	75~84.5	76~84.5
標準フック	35t						35t								
フック重量	950kg						950kg								
標準巻掛本数	3						2								

カウンタウエイト 25t、アウトリガ張出幅 6.8m

ブーム+2.0m+3.5m油圧チルトジブ

単位:t

ブーム長さ(m) 作業半径 (m)	40.4			45.4			50.5			55.6			60.0		
	オフセット			オフセット			オフセット			オフセット			オフセット		
	0°	20°	40°	0°	20°	40°	0°	20°	40°	0°	20°	40°	0°	20°	40°
8.0	47.7														
9.0	44.9	42.5		38.0											
10.0	42.5	40.3	38.9	36.1	33.9			28.4							
11.0	35.5	36.9	37.1	34.4	32.4	31.1	27.0	25.5		23.9					
12.0	30.1	31.3	32.2	30.4	31.1	29.9	25.7	24.4	23.5	22.8	21.5				
14.0	22.3	23.3	24.0	22.7	23.6	24.3	23.4	22.5	21.7	20.8	19.9	19.2	19.7		
16.0	17.0	17.8	18.4	17.4	18.1	18.7	18.1	18.8	19.4	18.7	18.5	18.0	18.2	17.5	17.1
18.0	13.2	13.9	14.3	13.5	14.2	14.6	14.2	14.8	15.3	14.8	15.4	15.9	15.0	15.6	15.9
20.0	10.3	10.8	11.2	10.6	11.2	11.5	11.3	11.8	12.2	11.9	12.4	12.8	12.0	12.5	12.9
22.0	7.7	8.3	8.6	8.1	8.7	9.1	8.9	9.4	9.8	9.6	10.0	10.3	9.7	10.1	10.4
24.0	5.6	6.1	6.4	6.0	6.5	6.8	6.8	7.3	7.6	7.5	8.0	8.3	7.6	8.1	8.4
26.0	3.9	4.3	4.6	4.3	4.7	5.0	5.0	5.5	5.8	5.7	6.2	6.5	5.8	6.3	6.6
28.0								3.6	4.0	4.2	4.3	4.7	4.9	4.4	5.0
30.0												3.6			
θ(°)	55~ 84.5	57~ 84.5	57~ 84.5	60~ 84.5	61~ 84.5	62~ 84.5	61~ 84.5	62~ 84.5	62~ 84.5	64~ 84.5	65~ 84.5	63~ 84.5	66~ 84.5	67~ 84.5	68~ 84.5
標準フック	80t						35t								
フック重量	1550kg						950kg								
標準巻掛本数	5						4						3		

カウンタウエイト 25t、アウトリガ張出幅 6.8m

ブーム+2.0m+11.5m油圧チルトジブ

単位:t

ブーム長さ(m) 作業半径 (m)	40.4			45.4			50.5			55.6			60.0		
	オフセット			オフセット			オフセット			オフセット			オフセット		
	0°	20°	40°	0°	20°	40°	0°	20°	40°	0°	20°	40°	0°	20°	40°
10.0	38.8														
11.0	36.3			31.1											
12.0	30.8			29.6			23.3								
14.0	23.1	26.2		23.4	23.4		21.2			18.8					
16.0	17.8	20.4	22.6	18.1	20.7		18.4	16.7		17.4	14.9		15.6		
18.0	13.9	16.1	18.0	14.2	16.4	18.3	14.6	15.8	14.0	15.1	14.0		14.9		
20.0	11.0	12.9	14.5	11.3	13.2	14.8	11.6	13.5	13.4	12.1	13.2	12.0	12.0	12.5	
22.0	8.6	10.4	11.8	8.9	10.7	12.0	9.3	11.0	12.3	9.8	11.4	11.4	9.7	11.3	
24.0	6.5	8.3	9.5	6.8	8.6	9.8	7.2	8.9	10.1	7.7	9.3	10.5	7.6	9.2	10.4
26.0	4.8	6.4	7.7	5.1	6.7	8.0	5.5	7.1	8.3	6.0	7.6	8.7	5.8	7.5	8.6
28.0		4.8	5.9	3.6	5.1	6.3		5.5	6.7	4.5	6.0	7.2		5.9	7.1
30.0			4.4		3.7	4.8		4.1	5.2		4.6	5.7			5.6
32.0						3.5			3.9			4.4			
θ(°)	61~ 83	63~ 84.5	64~ 84.5	62~ 83	64~ 84.5	64~ 84.5	66~ 83	66~ 84.5	67~ 84.5	67~ 83	69~ 84.5	69~ 84.5	70~ 83	72~ 84.5	73~ 84.5
標準フック	80t						35t								
フック重量	1550kg						950kg								
標準巻掛本数	4						3								

油圧チルトジブ

カウンタウエイト 25t、アウトリガ張出幅 6.8m

ブーム+2.0m+17.5m油圧チルトジブ

単位:t

ブーム長さ(m) 作業半径 (m)	40.4			45.4			50.5			55.6			60.0		
	オフセット			オフセット			オフセット			オフセット			オフセット		
	0°	20°	40°	0°	20°	40°	0°	20°	40°	0°	20°	40°	0°	20°	40°
11.0	31.5														
12.0	30.3			27.0											
14.0	23.9			23.9			19.5								
16.0	18.5	20.6		18.5			17.9			15.6				14.8	
18.0	14.6	17.8		14.6	17.8		15.1	13.4		14.5				13.7	
20.0	11.7	14.4		11.7	14.5		12.1	12.7		12.3	11.3			12.1	
22.0	9.3	11.8	13.9	9.3	11.8		9.8	12.0		10.0	10.7			9.8	10.2
24.0	7.2	9.6	11.5	7.2	9.7	11.5	7.7	10.0	10.1	7.9	10.1			7.7	9.6
26.0	5.5	7.9	9.5	5.5	7.9	9.6	5.9	8.3	9.7	6.2	8.4	8.7		8.3	8.3
28.0	4.0	6.2	7.8		6.2	7.9		6.7	8.2		6.9	8.3		6.7	7.9
30.0		4.7	6.4		4.8	6.5		5.2	6.8		5.4	7.0			6.9
32.0		3.5	4.9			5.0			5.5			5.7			5.6
34.0			3.7			3.8			4.2			4.5			
θ (°)	62~ 83	64~ 84.5	66~ 84.5	67~ 83	69~ 84.5	69~ 84.5	69~ 83	71~ 84.5	71~ 84.5	71~ 83	73~ 84.5	73~ 84.5	74~ 83	76~ 84.5	76~ 84.5
標準フック	35t						35t								
フック重量	950kg						950kg								
標準巻掛本数	3						2								

PS+油圧チルトジブ

PS+ブーム+油圧チルトジブ(HLJ)作業半径-揚程図

PS+ブーム+油圧チルトジブ

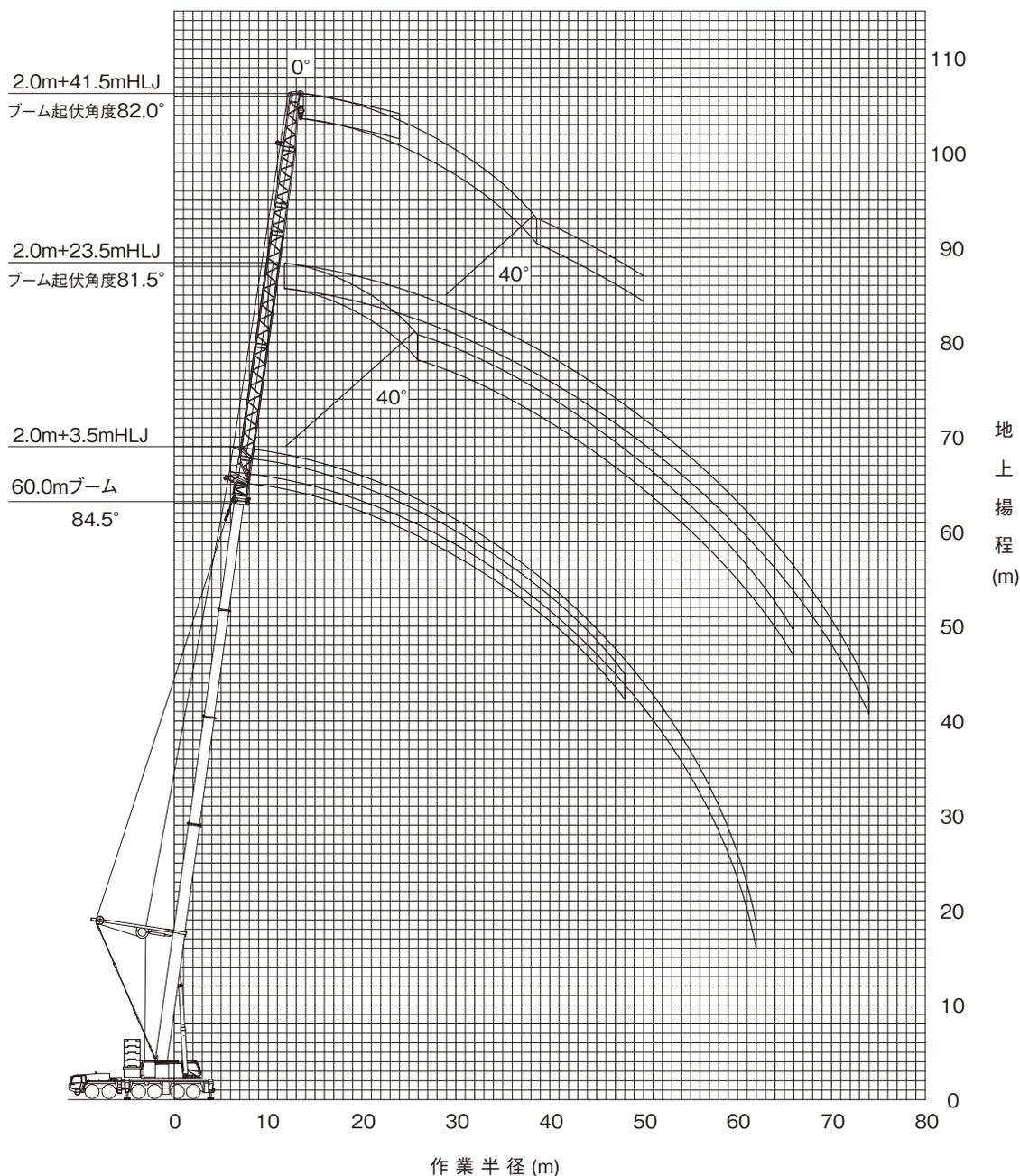

(注意)

- ◆ 上図はブームおよびジブのたわみを含んでいません。
- ◆ カウンタウエイト138t、アウトリガ張出幅8.5mの性能を図示しています。

PS+ブーム+油圧チルトジブ(HLJ)定格総荷重表

■ 定格総荷重表注意事項

◆性能設定のあるカウンタウエイトとアウトリガ張出幅の組合せを、下表に○印で示します。

アウトリガ張出幅 \ カウンタウエイト	138 t	118 t	98 t	78 t	58 t	47 t	25 t
8.5 m	○	○	○	○	○	○	○
8.0 m	○	○	○	○	○	○	○
6.8 m	○	○	○	○	○	○	○

◆定格総荷重は、つり具質量とフック質量(80トンフック: 1,550kg、35トンフック:950kg、12.2トンフック:440kg)を含んだ値を示します。

◆定格総荷重は、ブームとジブのたわみを含んだ実際の作業半径に基づいています。

◆各ブーム長さにおける各伸縮ブームの伸長状態(伸長割合%)は、下表のとおりです。

ブーム長さ	40.4 m	45.4 m	50.5 m	55.6 m	60.0 m
伸縮ブーム1	90	90	90	90	100
伸縮ブーム2	90	90	90	90	100
伸縮ブーム3	45	90	90	90	100
伸縮ブーム4	0	0	45	90	100

◆ブーム長さ40.4m未満での性能設定はありません。また、Bピン(ブーム固定ピン)を挿入していない状態では使用できません。

◆定格総荷重表中の標準巻掛本数より少ない本数で使用する場合、最大荷重の上限は下表のとおりです。

巻掛本数	4本	3本	2本	1本
最大荷重	47.4t	35.9t	24.1t	12.2t

◆定格総荷重は、アウトリガを水平堅土上に設置したときの値です。

◆定格総荷重表は、風による影響を含んでいません。瞬間最大風速が10m/s以上の風速では、クレーン作業を中止してください。

定格総荷重表中の線、および用語説明

◆太線より上側はクレーンの強度に、下側はクレーンの安定に基づいています。

◆「オフセット」はブームの中心線とジブの中心線とのなす角度を示します。

◆「 θ (°)」は、無負荷状態で作動可能なブーム起伏角度範囲を示します。

PS+油圧チルトジブ

カウンタウエイト 138t、アウトリガ張出幅 8.5m

PS+ブーム+2.0m+3.5m油圧チルトジブ

単位:t

ブーム長さ(m) 作業半径 (m)	40.4			45.4			50.5			55.6			60.0		
	オフセット			オフセット			オフセット			オフセット			オフセット		
	0°	20°	40°	0°	20°	40°	0°	20°	40°	0°	20°	40°	0°	20°	40°
9.0	58.6			52.9											
10.0	58.6	58.6		52.0	48.4		34.9								
11.0	58.6	57.7	52.9	50.7	47.2	45.0	33.7	30.3			28.3				
12.0	58.6	56.5	51.9	49.5	46.2	44.1	32.6	29.4	27.4	27.3	25.1			26.0	
14.0	56.8	54.2	50.2	47.3	44.4	42.5	30.6	27.8	26.1	25.5	23.6	22.4	24.3	22.5	21.4
16.0	50.2	48.4	47.2	45.4	42.8	41.1	28.9	26.4	24.9	23.9	22.2	21.2	22.8	21.3	20.3
18.0	44.8	43.4	42.5	42.5	41.1	39.9	27.4	25.2	23.9	22.5	21.1	20.1	21.5	20.2	19.3
20.0	40.3	39.2	38.6	38.3	37.2	36.5	26.1	24.1	22.9	21.3	20.0	19.2	20.4	19.2	18.4
22.0	36.5	35.7	35.2	34.7	33.8	33.3	24.9	23.1	22.1	20.2	19.1	18.4	19.4	18.3	17.6
24.0	33.3	32.7	32.3	31.6	30.9	30.6	23.8	22.3	21.4	19.3	18.2	17.6	18.5	17.5	16.9
26.0	30.6	30.1	29.8	29.0	28.4	28.2	22.9	21.5	20.7	18.4	17.5	16.9	17.6	16.8	16.2
28.0	28.2	27.7	27.6	26.7	26.3	26.0	22.1	20.8	20.1	17.6	16.8	16.3	16.8	16.1	15.6
30.0	26.0	25.7	25.6	24.7	24.3	24.2	21.3	20.1	19.5	16.9	16.1	15.7	15.6	15.2	14.9
32.0	24.2	23.9	23.8	22.9	22.6	22.5	20.6	19.5	19.0	16.2	15.6	15.2	14.5	14.1	13.9
34.0	22.5	22.3	22.3	21.3	21.1	21.0	20.0	19.0	18.6	15.7	15.0	14.7	13.5	13.2	13.0
36.0	21.0	20.9		19.8	19.7	19.6	19.4	18.6	18.2	15.1	14.6	14.3	12.6	12.3	12.2
38.0	19.2	19.5		18.6	18.4	18.4	18.1	18.0	17.9	14.6	14.1	13.9	11.8	11.6	11.5
40.0	16.1	16.4		17.4	17.3		17.0	16.8	16.8	14.2	13.7	13.5	11.0	10.9	10.8
42.0	12.2			16.3	16.2		16.0	15.9	15.8	13.8	13.4	13.2	10.4	10.2	10.2
44.0	3.8			14.3	14.6		15.0	14.9		13.4	13.0	12.9	9.7	9.6	9.6
46.0				11.5	11.7		14.2	14.1		13.1	12.7	12.7	9.2	9.1	9.1
48.0				7.4			13.0	13.2		12.8	12.5		8.7	8.6	8.6
50.0							10.8	11.0		12.4	12.3		8.2	8.1	
54.0							2.5			10.1	10.3		7.1	7.2	
58.0										4.9			6.1	6.2	
62.0													4.4		
θ(°)	0~ 81	27~ 81	43~ 81	13~ 82	23~ 82	42~ 82	0~ 83	25~ 83	42~ 83	13~ 84	27~ 84	42~ 84	15~ 84	27~ 84	45~ 84
標準フック	80t						35t								
フック重量	1550kg						950kg								
標準巻掛本数	5						3								

カウンタウエイト 138t、アウトリガ張出幅 8.5m

PS+ブーム+2.0m+11.5m油圧チルトジブ

単位:t

ブーム長さ(m) 作業半径 (m)	40.4			45.4			50.5			55.6			60.0		
	オフセット			オフセット			オフセット			オフセット			オフセット		
	0°	20°	40°	0°	20°	40°	0°	20°	40°	0°	20°	40°	0°	20°	40°
10.0	45.4														
11.0	45.4			36.6											
12.0	44.8			36.6			27.9								
14.0	42.2	32.1		36.6	30.8		25.8			22.3			19.5		
16.0	39.8	30.6	24.5	36.6	29.6		24.0	19.0		20.7	17.0		19.5		
18.0	37.6	29.3	23.9	36.1	28.4	24.2	22.5	18.0	15.5	19.3	16.0		18.4	15.4	
20.0	35.3	28.1	23.3	33.9	27.4	23.5	21.1	17.1	14.9	18.1	15.2	13.5	17.3	14.6	
22.0	32.0	27.1	22.8	30.6	26.4	22.8	19.9	16.4	14.3	17.0	14.4	12.9	16.3	13.9	12.4
24.0	29.2	26.1	22.3	27.9	25.6	22.3	18.8	15.7	13.8	16.1	13.7	12.4	15.4	13.2	11.9
26.0	26.7	25.3	21.9	25.5	24.1	21.8	17.9	15.0	13.4	15.2	13.1	11.9	14.6	12.6	11.4
28.0	24.6	23.5	21.5	23.5	22.3	21.3	17.1	14.4	12.9	14.4	12.6	11.4	13.9	12.1	11.0
30.0	22.7	21.8	21.2	21.7	20.7	20.2	16.3	13.9	12.5	13.7	12.0	11.0	13.1	11.6	10.6
32.0	21.1	20.3	19.9	20.1	19.3	18.9	15.6	13.4	12.2	13.1	11.6	10.6	12.1	11.1	10.3
34.0	19.6	19.0	18.7	18.6	18.0	17.6	15.0	13.0	11.9	12.5	11.1	10.3	11.2	10.5	9.9
36.0	18.3	17.8	17.5	17.4	16.8	16.5	14.4	12.6	11.6	12.0	10.7	10.0	10.4	9.8	9.5
38.0	17.1	16.7	16.5	16.2	15.8	15.6	13.9	12.2	11.3	11.5	10.3	9.7	9.7	9.2	8.9
40.0	16.0	15.7	15.5	15.1	14.8	14.6	13.4	11.9	11.0	11.1	10.0	9.4	9.0	8.6	8.4
42.0	15.0	14.8	14.7	14.2	13.9	13.8	12.9	11.5	10.8	10.7	9.7	9.1	8.4	8.1	7.9
44.0	14.1	13.9		13.3	13.1	13.0	12.5	11.3	10.6	10.3	9.4	8.9	7.9	7.6	7.4
46.0	13.3	13.1		12.5	12.3	12.3	12.2	11.0	10.4	10.0	9.1	8.7	7.4	7.1	7.0
48.0	11.4	12.4		11.8	11.6		11.5	10.8	10.3	9.6	8.9	8.5	6.9	6.7	6.6
50.0	8.3			11.1	11.0		10.8	10.6	10.2	9.3	8.6	8.3	6.5	6.3	6.3
54.0				8.0	9.2		9.6	9.5		8.8	8.2	8.0	5.7	5.6	5.6
58.0							7.5	8.6		8.4	7.9		5.1	5.0	
62.0										7.1	7.5		4.5	4.5	
66.0										2.7			4.0	4.0	
70.0													2.4		
θ(°)	17~ 82	28~ 82	44~ 81	20~ 83	24~ 83	44~ 83	22~ 83	26~ 84	43~ 84	12~ 83	28~ 84.5	43~ 84.5	14~ 83	28~ 84.5	48~ 84.5
標準フック	80t						35t								
フック重量	1550kg						950kg								
標準巻掛本数	4						3								

カウンタウエイト 138t、アウトリガ張出幅 8.5m

PS+ブーム+2.0m+17.5m油圧チルトジブ

単位:t

ブーム長さ(m) 作業半径 (m)	40.4			45.4			50.5			55.6			60.0		
	オフセット			オフセット			オフセット			オフセット			オフセット		
	0°	20°	40°	0°	20°	40°	0°	20°	40°	0°	20°	40°	0°	20°	40°
11.0	32.6														
12.0	32.6			28.2											
14.0	32.6			28.2			21.7								
16.0	31.2	21.3		28.2			21.0			16.9			14.4		
18.0	29.4	20.2		28.1	20.7		19.6	14.9		16.9			14.0		
20.0	27.9	19.2		26.9	19.8		18.3	14.1		15.9	12.7		13.6		
22.0	26.5	18.3	14.0	25.6	18.9		17.2	13.4		14.9	12.1		13.1	11.6	
24.0	25.2	17.5	13.6	24.5	18.0	13.8	16.2	12.8	11.0	14.0	11.5		12.7	11.1	
26.0	24.0	16.7	13.3	23.2	17.3	13.5	15.3	12.3	10.6	13.2	10.9	9.6	12.1	10.6	9.3
28.0	22.4	16.1	12.9	21.3	16.6	13.1	14.5	11.8	10.2	12.5	10.4	9.2	11.6	10.1	8.9
30.0	20.7	15.4	12.7	19.7	16.0	12.9	13.8	11.3	9.9	11.9	10.0	8.9	11.1	9.7	8.6
32.0	19.2	14.9	12.4	18.2	15.5	12.6	13.2	10.9	9.6	11.3	9.6	8.6	10.6	9.3	8.3
34.0	17.8	14.4	12.2	16.9	15.0	12.4	12.6	10.5	9.3	10.8	9.2	8.3	9.8	8.9	8.0
36.0	16.6	13.9	12.0	15.8	14.5	12.2	12.1	10.1	9.1	10.3	8.8	8.0	9.1	8.4	7.6
38.0	15.5	13.5	11.8	14.7	14.0	12.0	11.6	9.8	8.8	9.8	8.5	7.8	8.4	7.8	7.3
40.0	14.5	13.1	11.7	13.7	13.3	11.8	11.1	9.5	8.6	9.4	8.2	7.5	7.8	7.3	7.0
42.0	13.6	12.8	11.6	12.8	12.5	11.7	10.7	9.2	8.4	9.0	7.9	7.3	7.3	6.9	6.7
44.0	12.8	12.5	11.5	12.0	11.8	11.6	10.3	9.0	8.2	8.7	7.7	7.1	6.7	6.4	6.3
46.0	12.0	11.8	11.5	11.3	11.1	11.0	10.0	8.7	8.0	8.4	7.4	6.9	6.3	6.0	5.9
48.0	11.3	11.2	11.1	10.6	10.4	10.4	9.7	8.5	7.9	8.1	7.2	6.7	5.9	5.6	5.6
50.0	10.7	10.6		10.0	9.9	9.8	9.4	8.3	7.8	7.8	7.0	6.6	5.5	5.3	5.3
54.0	9.0	9.5		8.9	8.8		8.6	7.9	7.5	7.3	6.6	6.3	4.8	4.7	4.7
58.0				7.9	7.9		7.7	7.6		6.8	6.3	6.0	4.2	4.1	4.2
62.0				3.2			6.8	6.8		6.5	6.0		3.6	3.6	3.7
66.0							3.8			5.9	5.8		3.2	3.2	
70.0										3.9	5.1		2.8	2.8	
74.0													2.5	2.5	
θ (°)	23~ 83	28~ 83	44~ 83	11~ 83	30~ 84	48~ 84	16~ 83	31~ 84	47~ 84	19~ 83	23~ 84.5	47~ 84.5	20~ 83	24~ 84.5	46~ 84.5
標準フック	35t						35t								
フック重量	950kg						950kg								
標準巻掛本数	3						2								

カウンタウエイト 138t、アウトリガ張出幅 8.5m

PS+ブーム+2.0m+23.5m油圧チルトジブ

単位:t

ブーム長さ(m) 作業半径 (m)	40.4			45.4			50.5			55.6			60.0		
	オフセット			オフセット			オフセット			オフセット			オフセット		
	0°	20°	40°	0°	20°	40°	0°	20°	40°	0°	20°	40°	0°	20°	40°
12.0	24.7														
14.0	24.7			21.4			16.6								
16.0	24.7			21.4			16.6			12.7					
18.0	24.3			21.4			16.6			12.7			10.4		
20.0	23.0	14.4		21.4			16.1			12.7			10.0		
22.0	21.7	13.6		21.1	14.0		15.1	11.3		12.7			9.6		
24.0	20.1	12.9		20.1	13.3		14.1	10.8		12.4	9.8		9.2		
26.0	18.6	12.3	9.3	19.2	12.7		13.3	10.3		11.7	9.4		8.8	9.0	
28.0	17.3	11.7	9.0	18.4	12.1	9.1	12.6	9.9		11.0	8.9		8.3	8.6	
30.0	16.1	11.2	8.7	17.4	11.6	8.9	12.0	9.5	8.1	10.4	8.5	7.4	7.9	8.2	
32.0	15.1	10.7	8.5	16.3	11.2	8.6	11.4	9.1	7.8	9.9	8.1	7.1	7.4	7.7	6.5
34.0	14.2	10.3	8.3	15.3	10.7	8.4	10.8	8.7	7.6	9.4	7.8	6.9	7.0	7.3	6.2
36.0	13.4	9.9	8.1	14.4	10.3	8.2	10.3	8.4	7.3	8.9	7.5	6.6	6.6	6.8	5.9
38.0	12.6	9.6	7.9	13.4	10.0	8.1	9.9	8.1	7.1	8.5	7.2	6.4	6.1	6.5	5.7
40.0	12.0	9.2	7.7	12.5	9.6	7.9	9.5	7.8	6.9	8.1	6.9	6.2	5.8	6.1	5.4
42.0	11.4	8.9	7.6	11.7	9.3	7.7	9.1	7.6	6.7	7.8	6.7	6.0	5.4	5.8	5.1
44.0	10.8	8.6	7.5	11.0	9.0	7.6	8.7	7.3	6.6	7.5	6.4	5.8	5.0	5.5	4.9
46.0	10.3	8.4	7.4	10.3	8.7	7.5	8.4	7.1	6.4	7.2	6.2	5.6	4.7	5.1	4.7
48.0	9.8	8.1	7.3	9.6	8.5	7.4	8.1	6.9	6.3	6.9	6.0	5.5	4.4	4.8	4.5
50.0	9.4	7.9	7.2	9.1	8.3	7.3	7.8	6.7	6.1	6.6	5.8	5.3	4.1	4.4	4.3
54.0	8.6	7.6	7.2	8.0	7.9	7.2	7.3	6.4	5.9	6.1	5.4	5.0	3.5	3.9	3.9
58.0	7.7	7.3		7.1	7.0	7.1	6.8	6.1	5.7	5.7	5.1	4.8	3.0	3.4	3.4
62.0	4.7			6.3	6.3		6.0	5.8	5.5	5.3	4.8	4.5	2.5	2.9	3.0
66.0				4.6	5.6		5.3	5.3		4.9	4.4	4.3	2.1	2.5	2.6
70.0							4.3	4.7		4.5	4.2		1.8	2.1	
74.0										3.9	3.9		1.5	1.8	
78.0															1.6
θ (°)	16~ 83	33~ 83	45~ 83	19~ 83	25~ 84	45~ 84	21~ 83	27~ 84.5	45~ 84.5	23~ 83	29~ 84.5	45~ 84.5	30~ 83	30~ 84.5	50~ 84.5
標準フック	35t						35t								
フック重量	950kg						950kg								
標準巻掛本数	3						2								

PS+油圧チルトジブ

カウンタウエイト 138t、アウトリガ張出幅 8.5m

PS+ブーム+2.0m+29.5m油圧チルトジブ

単位:t

ブーム長さ(m) 作業半径 (m)	40.4			45.4			50.5			55.6			60.0		
	オフセット			オフセット			オフセット			オフセット			オフセット		
	0°	20°	40°	0°	20°	40°	0°	20°	40°	0°	20°	40°	0°	20°	40°
14.0	18.7			16.1											
16.0	18.7			16.1			12.4								
18.0	18.7			16.1			12.4							7.0	
20.0	18.7			16.1			12.4			8.7				6.7	
22.0	17.8			16.1			12.4			8.7				6.3	
24.0	16.5	10.2		16.1	10.5		12.4			8.7				6.0	
26.0	15.2	9.6		15.7	9.9		11.8	8.9		8.6				5.6	
28.0	14.1	9.1		15.1	9.4		11.1	8.5		8.4	8.0			5.3	
30.0	13.1	8.7		14.1	9.0		10.5	8.1		8.3	7.6			4.9	6.7
32.0	12.2	8.3	6.2	13.1	8.6	6.3	10.0	7.8		8.1	7.3			4.6	6.3
34.0	11.4	7.9	6.0	12.3	8.2	6.1	9.5	7.5	6.2	7.9	6.9			4.2	5.9
36.0	10.7	7.6	5.9	11.5	7.9	6.0	9.0	7.2	6.0	7.7	6.6	5.8		3.9	5.5
38.0	10.0	7.2	5.7	10.9	7.5	5.8	8.6	6.9	5.9	7.5	6.4	5.6		3.5	5.2 4.4
40.0	9.5	6.9	5.5	10.2	7.2	5.6	8.2	6.6	5.7	7.3	6.1	5.4		3.2	4.9 4.2
42.0	8.9	6.7	5.4	9.7	7.0	5.5	7.8	6.4	5.6	7.0	5.8	5.2		2.9	4.6 4.0
44.0	8.5	6.4	5.3	9.2	6.7	5.4	7.5	6.2	5.4	6.7	5.6	5.0		2.6	4.3 3.8
46.0	8.0	6.2	5.1	8.7	6.5	5.2	7.2	6.0	5.2	6.4	5.4	4.8		2.3	4.1 3.6
48.0	7.6	6.0	5.0	8.3	6.3	5.1	6.9	5.8	5.1	6.1	5.2	4.6		2.1	3.9 3.4
50.0	7.2	5.8	5.0	7.9	6.1	5.0	6.7	5.6	5.0	5.9	5.0	4.4		1.8	3.6 3.3
54.0	6.6	5.4	4.8	7.1	5.7	4.9	6.2	5.2	4.7	5.3	4.5	4.0			3.2 3.0
58.0	6.0	5.1	4.8	6.3	5.4	4.8	5.8	4.9	4.4	4.8	4.1	3.7			2.7 2.7
62.0	5.5	4.9		5.5	5.1	4.7	5.2	4.6	4.2	4.3	3.8	3.4			2.3 2.4
66.0	5.1	4.8		4.9	4.9		4.6	4.3	4.0	3.9	3.4	3.2			1.9 2.0
70.0				4.3	4.3		4.0	4.0		3.6	3.2	3.0			1.6 1.7
74.0							3.5	3.5		3.1	2.9				
78.0										2.7	2.8				
82.0										1.8	2.4				
θ(°)	21~ 83	29~ 84	49~ 84	23~ 83	31~ 84.5	49~ 84.5	25~ 83	32~ 84.5	49~ 84.5	19~ 83	26~ 84.5	49~ 84.5	59~ 83	49~ 84.5	53~ 84.5
標準フック	35t						12.2t								
フック重量	950kg						440kg								
標準巻掛本数	2						1								

カウンタウエイト 138t、アウトリガ張出幅 8.5m

PS+ブーム+2.0m+35.5m油圧チルトジブ

単位:t

ブーム長さ(m) 作業半径 (m)	40.4			45.4			50.5			55.6			60.0		
	オフセット			オフセット			オフセット			オフセット			オフセット		
	0°	20°	40°	0°	20°	40°	0°	20°	40°	0°	20°	40°	0°	20°	40°
14.0	14.1														
16.0	14.1			12.2											
18.0	14.1			12.2			8.8								
20.0	14.1			12.2			8.8			6.1				4.4	
22.0	14.1			12.2			8.8			6.1				4.2	
24.0	13.9			12.2			8.8			6.1				3.8	
26.0	13.0	7.9		12.2			8.8			6.0				3.5	
28.0	12.0	7.5		12.2	7.7		8.8			5.8				3.2	
30.0	11.1	7.1		11.8	7.3		8.8	7.4		5.7				2.9	
32.0	10.3	6.7		11.1	6.9		8.8	7.1		5.5	6.5			2.6	5.4
34.0	9.6	6.4		10.3	6.6		8.8	6.8		5.3	6.2			2.2	5.0
36.0	8.9	6.1	4.5	9.7	6.3		8.3	6.5		5.2	5.9			1.9	4.7
38.0	8.4	5.8	4.3	9.0	6.0	4.4	7.9	6.2		5.0	5.6			1.6	4.4
40.0	7.9	5.5	4.2	8.5	5.7	4.2	7.5	6.0	4.5	4.8	5.4				4.1
42.0	7.4	5.3	4.0	8.0	5.5	4.1	7.2	5.7	4.4	4.6	5.1	4.4			3.9 3.3
44.0	7.0	5.0	3.9	7.5	5.3	4.0	6.9	5.5	4.3	4.3	4.9	4.2			3.6 3.1
46.0	6.6	4.8	3.8	7.1	5.0	3.9	6.6	5.3	4.1	4.1	4.6	4.0			3.4 2.9
48.0	6.2	4.6	3.7	6.7	4.8	3.7	6.3	5.1	4.0	3.9	4.3	3.8			3.2 2.7
50.0	5.9	4.4	3.6	6.4	4.7	3.7	6.0	4.9	3.9	3.7	4.1	3.6			3.0 2.6
54.0	5.3	4.1	3.4	5.8	4.3	3.5	5.6	4.5	3.7	3.2	3.7	3.2			2.6 2.3
58.0	4.8	3.8	3.3	5.2	4.0	3.3	5.0	4.1	3.6	2.7	3.3	2.9			2.3 2.0
62.0	4.3	3.6	3.2	4.7	3.8	3.2	4.6	3.8	3.4	2.3	3.0	2.6			1.9 1.8
66.0	4.0	3.4	3.2	4.3	3.6	3.2	4.2	3.5	3.2	1.8	2.7	2.4			1.6
70.0	3.6	3.3		3.8	3.4	3.2	3.6	3.3	3.0		2.4	2.2			
74.0	2.2			3.3	3.3		3.1	3.1	2.9		2.2	2.0			
78.0				2.1	2.9		2.6	2.7			2.0	1.8			
82.0							2.2	2.3							
86.0										1.8					
88.0										1.6					
θ(°)	14~ 83	34~ 84.5	46~ 84.5	18~ 83	26~ 84.5	47~ 84.5	21~ 83	29~ 84.5	47~ 84.5	47~ 83	32~ 84.5	48~ 84.5	70~ 83	61~ 84.5	63~ 84.5
標準フック	35t						12.2t								
フック重量	950kg						440kg								
標準巻掛本数	2						1								

カウンタウエイト 138t、アウトリガ張出幅 8.5m

PS+ブーム+2.0m+41.5m油圧チルトジブ

単位:t

ブーム長さ(m) 作業半径 (m)	40.4			45.4			50.5			55.6			60.0		
	オフセット			オフセット			オフセット			オフセット			オフセット		
	0°	20°	40°	0°	20°	40°	0°	20°	40°	0°	20°	40°	0°	20°	40°
16.0	10.1			8.6											
18.0	10.1			8.6			6.0								
20.0	10.1			8.6			6.0					3.5			
22.0	10.1			8.6			6.0				3.5			1.9	
24.0	10.1			8.6			6.0				3.5			1.6	
26.0	10.1			8.6			6.0				3.4				
28.0	10.1			8.6			6.0				3.2				
30.0	9.5	5.8		8.6			6.0				3.1				
32.0	8.8	5.4		8.6	5.6		6.0				2.9				
34.0	8.2	5.1		8.6	5.3		6.0	5.4			2.8				
36.0	7.6	4.8		8.2	5.0		6.0	5.1			2.6	4.8			3.1
38.0	7.0	4.5		7.6	4.7		6.0	4.9			2.4	4.6			3.1
40.0	6.5	4.2		7.1	4.4		6.0	4.6			2.2	4.3			3.1
42.0	6.1	4.0	2.8	6.6	4.2		6.0	4.4			2.0	4.0			2.9
44.0	5.7	3.8	2.6	6.2	4.0	2.7	5.9	4.1			1.8	3.7			2.7
46.0	5.3	3.6	2.5	5.8	3.8	2.6	5.6	3.9	2.6		1.6	3.5			2.5
48.0	4.9	3.4	2.4	5.4	3.6	2.5	5.3	3.7	2.5		3.2	2.6			2.3
50.0	4.6	3.2	2.3	5.1	3.4	2.4	5.0	3.6	2.4		3.0	2.5			2.1
54.0	4.1	2.9	2.1	4.5	3.1	2.2	4.4	3.2	2.3		2.6	2.2			1.7
58.0	3.6	2.6	2.0	4.0	2.8	2.0	3.9	2.9	2.1		2.3	1.9			
62.0	3.2	2.3	1.8	3.5	2.5	1.9	3.5	2.7	2.0		1.9	1.6			
66.0	2.8	2.1	1.7	3.1	2.3	1.8	3.1	2.4	1.8		1.6				
70.0	2.5	1.9	1.7	2.8	2.1	1.7	2.7	2.1	1.8						
74.0	2.2	1.8		2.5	1.9	1.7	2.3	1.9	1.6						
78.0	1.9	1.7		2.1	1.8		1.8	1.7	1.5						
82.0				1.7	1.7			1.5							
θ (°)	20~ 83	30~ 84.5	51~ 84.5	23~ 83	32~ 84.5	51~ 84.5	35~ 83	40~ 84.5	51~ 84.5	65~ 83	60~ 84.5	70~ 84.5	80~ 83	70~ 84.5	80~ 84.5
標準フック	12.2t														
フック重量	440kg														
標準巻掛本数	1														

カウンタウエイト 138t、アウトリガ張出幅 8.5m

PS+ブーム+2.0m+47.5m油圧チルトジブ

単位:t

ブーム長さ(m) 作業半径 (m)	40.4		45.4		50.5	
	オフセット		オフセット		オフセット	
	0°	20°	0°	20°	0°	20°
16.0	6.7					
18.0	6.7		5.6			
20.0	6.7		5.6		3.3	
22.0	6.7		5.6		3.3	
24.0	6.7		5.6		3.3	
26.0	6.7		5.6		3.3	
28.0	6.7		5.6		3.3	
30.0	6.7		5.6		3.3	
32.0	6.7		5.6		3.3	
34.0	6.4	3.7	5.6		3.3	
36.0	5.9	3.5	5.6	3.6	3.3	
38.0	5.4	3.2	5.6	3.4	3.3	3.5
40.0	5.0	3.0	5.4	3.1	3.3	3.3
42.0	4.6	2.8	5.0	2.9	3.3	3.1
44.0	4.3	2.6	4.7	2.7	3.3	2.9
46.0	4.0	2.4	4.3	2.6	3.3	2.7
48.0	3.7	2.3	4.0	2.4	3.3	2.5
50.0	3.4	2.1	3.7	2.2	3.3	2.4
54.0	2.9	1.8	3.2	1.9	3.3	2.1
58.0	2.5	1.6	2.8	1.7	2.9	1.8
62.0	2.1		2.4	1.5	2.5	1.6
66.0	1.8		2.1		2.2	
70.0	1.5		1.8		1.8	
74.0			1.5		1.5	
θ (°)	40~ 84.5	62~ 84.5	40~ 84.5	62~ 84.5	44~ 84.5	65~ 84.5
標準フック	12.2t					
フック重量	440kg					
標準巻掛本数	1					

PS+油圧チルトジブ

カウンタウエイト 118t、アウトリガ張出幅 8.5m

PS+ブーム+2.0m+3.5m油圧チルトジブ

単位:t

ブーム長さ(m) 作業半径 (m)	40.4			45.4			50.5			55.6			60.0		
	オフセット			オフセット			オフセット			オフセット			オフセット		
	0°	20°	40°	0°	20°	40°	0°	20°	40°	0°	20°	40°	0°	20°	40°
8.0	58.6														
9.0	58.6	58.6		52.9											
10.0	58.6	58.6	53.9	52.0	48.4		34.9								
11.0	58.6	57.7	52.9	50.7	47.2	45.0	33.7	30.3		28.3					
12.0	58.6	56.5	51.9	49.5	46.2	44.1	32.6	29.4	27.4	27.3	25.1		26.0		
14.0	56.8	54.2	50.2	47.3	44.4	42.5	30.6	27.8	26.1	25.5	23.6	22.4	24.3	22.5	21.4
16.0	50.2	48.4	47.2	45.4	42.8	41.1	28.9	26.4	24.9	23.9	22.2	21.2	22.8	21.3	20.3
18.0	44.8	43.4	42.5	42.5	41.1	39.9	27.4	25.2	23.9	22.5	21.1	20.1	21.5	20.2	19.3
20.0	40.3	39.2	38.6	38.3	37.2	36.5	26.1	24.1	22.9	21.3	20.0	19.2	20.4	19.2	18.4
22.0	36.5	35.7	35.2	34.7	33.8	33.3	24.9	23.1	22.1	20.2	19.1	18.4	19.4	18.3	17.6
24.0	33.3	32.7	32.3	31.6	30.9	30.6	23.8	22.3	21.4	19.3	18.2	17.6	18.5	17.5	16.9
26.0	30.6	30.1	29.8	29.0	28.4	28.2	22.9	21.5	20.7	18.4	17.5	16.9	17.6	16.8	16.2
28.0	28.2	27.7	27.6	26.7	26.3	26.0	22.1	20.8	20.1	17.6	16.8	16.3	16.8	16.1	15.6
30.0	26.0	25.7	25.6	24.7	24.3	24.2	21.3	20.1	19.5	16.9	16.1	15.7	15.6	15.2	14.9
32.0	24.2	23.9	23.8	22.9	22.6	22.5	20.6	19.5	19.0	16.2	15.6	15.2	14.5	14.1	13.9
34.0	22.5	22.3	22.3	21.3	21.1	21.0	20.0	19.0	18.6	15.7	15.0	14.7	13.5	13.2	13.0
36.0	20.4	20.5		19.8	19.7	19.6	19.4	18.6	18.2	15.1	14.6	14.3	12.6	12.3	12.2
38.0	18.4	18.6		18.6	18.4	18.4	18.1	18.0	17.9	14.6	14.1	13.9	11.8	11.6	11.5
40.0	16.1	16.4		17.2	17.3		17.0	16.8	16.8	14.2	13.7	13.5	11.0	10.9	10.8
42.0	12.2			15.7	15.8		16.0	15.9	15.8	13.8	13.4	13.2	10.4	10.2	10.2
44.0	3.8			14.3	14.4		14.9	14.9		13.4	13.0	12.9	9.7	9.6	9.6
46.0				11.5	11.7		13.7	13.8		13.1	12.7	12.7	9.2	9.1	9.1
48.0				7.4			12.5	12.6		12.8	12.5		8.7	8.6	8.6
50.0							10.8	11.0		12.0	12.1		8.2	8.1	
54.0							2.5			10.0	10.0		7.1	7.2	
58.0										4.9			6.1	6.2	
62.0													4.4		
θ(°)	0~ 84.5	27~ 84.5	43~ 84.5	13~ 84.5	23~ 84.5	42~ 84.5	0~ 84.5	25~ 84.5	42~ 84.5	13~ 84.5	27~ 84.5	42~ 84.5	15~ 84.5	27~ 84.5	45~ 84.5
標準フック	80t						35t								
フック重量	1550kg						950kg								
標準巻掛本数	5						3								

カウンタウエイト 118t、アウトリガ張出幅 8.5m

PS+ブーム+2.0m+11.5m油圧チルトジブ

単位:t

ブーム長さ(m) 作業半径 (m)	40.4			45.4			50.5			55.6			60.0		
	オフセット			オフセット			オフセット			オフセット			オフセット		
	0°	20°	40°	0°	20°	40°	0°	20°	40°	0°	20°	40°	0°	20°	40°
10.0	45.4														
11.0	45.4			36.6											
12.0	44.8			36.6			27.9								
14.0	42.2	32.1		36.6	30.8		25.8			22.3			19.5		
16.0	39.8	30.6	24.5	36.6	29.6		24.0	19.0		20.7	17.0		19.5		
18.0	37.6	29.3	23.9	36.1	28.4	24.2	22.5	18.0	15.5	19.3	16.0		18.4	15.4	
20.0	35.3	28.1	23.3	33.9	27.4	23.5	21.1	17.1	14.9	18.1	15.2	13.5	17.3	14.6	
22.0	32.0	27.1	22.8	30.6	26.4	22.8	19.9	16.4	14.3	17.0	14.4	12.9	16.3	13.9	12.4
24.0	29.2	26.1	22.3	27.9	25.6	22.3	18.8	15.7	13.8	16.1	13.7	12.4	15.4	13.2	11.9
26.0	26.7	25.3	21.9	25.5	24.1	21.8	17.9	15.0	13.4	15.2	13.1	11.9	14.6	12.6	11.4
28.0	24.6	23.5	21.5	23.5	22.3	21.3	17.1	14.4	12.9	14.4	12.6	11.4	13.9	12.1	11.0
30.0	22.7	21.8	21.2	21.7	20.7	20.2	16.3	13.9	12.5	13.7	12.0	11.0	13.1	11.6	10.6
32.0	21.1	20.3	19.9	20.1	19.3	18.9	15.6	13.4	12.2	13.1	11.6	10.6	12.1	11.1	10.3
34.0	19.6	19.0	18.7	18.6	18.0	17.6	15.0	13.0	11.9	12.5	11.1	10.3	11.2	10.5	9.9
36.0	18.3	17.8	17.5	17.4	16.8	16.5	14.4	12.6	11.6	12.0	10.7	10.0	10.4	9.8	9.5
38.0	17.1	16.7	16.5	16.2	15.8	15.6	13.9	12.2	11.3	11.5	10.3	9.7	9.7	9.2	8.9
40.0	16.0	15.7	15.5	15.1	14.8	14.6	13.4	11.9	11.0	11.1	10.0	9.4	9.0	8.6	8.4
42.0	15.0	14.8	14.7	14.2	13.9	13.8	12.9	11.5	10.8	10.7	9.7	9.1	8.4	8.1	7.9
44.0	14.1	13.9		13.3	13.1	13.0	12.5	11.3	10.6	10.3	9.4	8.9	7.9	7.6	7.4
46.0	13.3	13.1		12.5	12.3	12.3	12.2	11.0	10.4	10.0	9.1	8.7	7.4	7.1	7.0
48.0	11.4	12.4		11.8	11.6		11.5	10.8	10.3	9.6	8.9	8.5	6.9	6.7	6.6
50.0	8.3			11.1	11.0		10.8	10.6	10.2	9.3	8.6	8.3	6.5	6.3	6.3
54.0				8.0	9.2		9.6	9.5		8.8	8.2	8.0	5.7	5.6	5.6
58.0							7.5	8.5		8.4	7.9		5.1	5.0	
62.0										7.1	7.5		4.5	4.5	
66.0													4.0	4.0	
70.0													2.4		
θ(°)	17~ 83	28~ 84.5	44~ 84.5	20~ 83	24~ 84.5	44~ 84.5	22~ 83	26~ 84.5	43~ 84.5	12~ 83	28~ 84.5	43~ 84.5	14~ 83	28~ 84.5	48~ 84.5
標準フック	80t						35t								
フック重量	1550kg						950kg								
標準巻掛本数	4						3								

カウンタウエイト 118t、アウトリガ張出幅 8.5m

PS+ブーム+2.0m+17.5m油圧チルトジブ

単位:t

ブーム長さ(m) 作業半径 (m)	40.4			45.4			50.5			55.6			60.0		
	オフセット			オフセット			オフセット			オフセット			オフセット		
	0°	20°	40°	0°	20°	40°	0°	20°	40°	0°	20°	40°	0°	20°	40°
11.0	32.6														
12.0	32.6			28.2											
14.0	32.6			28.2			21.7								
16.0	31.2	21.3		28.2			21.0			16.9			14.4		
18.0	29.4	20.2		28.1	20.7		19.6	14.9		16.9			14.0		
20.0	27.9	19.2		26.9	19.8		18.3	14.1		15.9	12.7		13.6		
22.0	26.5	18.3	14.0	25.6	18.9		17.2	13.4		14.9	12.1		13.1	11.6	
24.0	25.2	17.5	13.6	24.5	18.0	13.8	16.2	12.8	11.0	14.0	11.5		12.7	11.1	
26.0	24.0	16.7	13.3	23.2	17.3	13.5	15.3	12.3	10.6	13.2	10.9	9.6	12.1	10.6	9.3
28.0	22.4	16.1	12.9	21.3	16.6	13.1	14.5	11.8	10.2	12.5	10.4	9.2	11.6	10.1	8.9
30.0	20.7	15.4	12.7	19.7	16.0	12.9	13.8	11.3	9.9	11.9	10.0	8.9	11.1	9.7	8.6
32.0	19.2	14.9	12.4	18.2	15.5	12.6	13.2	10.9	9.6	11.3	9.6	8.6	10.6	9.3	8.3
34.0	17.8	14.4	12.2	16.9	15.0	12.4	12.6	10.5	9.3	10.8	9.2	8.3	9.8	8.9	8.0
36.0	16.6	13.9	12.0	15.8	14.5	12.2	12.1	10.1	9.1	10.3	8.8	8.0	9.1	8.4	7.6
38.0	15.5	13.5	11.8	14.7	14.0	12.0	11.6	9.8	8.8	9.8	8.5	7.8	8.4	7.8	7.3
40.0	14.5	13.1	11.7	13.7	13.3	11.8	11.1	9.5	8.6	9.4	8.2	7.5	7.8	7.3	7.0
42.0	13.6	12.8	11.6	12.8	12.5	11.7	10.7	9.2	8.4	9.0	7.9	7.3	7.3	6.9	6.7
44.0	12.8	12.5	11.5	12.0	11.8	11.6	10.3	9.0	8.2	8.7	7.7	7.1	6.7	6.4	6.3
46.0	12.0	11.8	11.5	11.3	11.1	11.0	10.0	8.7	8.0	8.4	7.4	6.9	6.3	6.0	5.9
48.0	11.3	11.2	11.1	10.6	10.4	10.4	9.7	8.5	7.9	8.1	7.2	6.7	5.9	5.6	5.6
50.0	10.7	10.6		10.0	9.9	9.8	9.4	8.3	7.8	7.8	7.0	6.6	5.5	5.3	5.3
54.0	9.0	9.5		8.9	8.8		8.6	7.9	7.5	7.3	6.6	6.3	4.8	4.7	4.7
58.0				7.9	7.9		7.7	7.6		6.8	6.3	6.0	4.2	4.1	4.2
62.0				3.2			6.8	6.8		6.5	6.0		3.6	3.6	3.7
66.0							3.8			5.9	5.8		3.2	3.2	
70.0										3.9	5.1		2.8	2.8	
74.0													2.5	2.5	
θ(°)	23~ 83	28~ 84.5	44~ 84.5	11~ 83	30~ 84.5	48~ 84.5	16~ 83	31~ 84.5	47~ 84.5	19~ 83	23~ 84.5	47~ 84.5	20~ 83	24~ 84.5	46~ 84.5
標準フック	35t						35t								
フック重量	950kg						950kg								
標準巻掛本数	3						2								

カウンタウエイト 118t、アウトリガ張出幅 8.5m

PS+ブーム+2.0m+23.5m油圧チルトジブ

単位:t

ブーム長さ(m) 作業半径 (m)	40.4			45.4			50.5			55.6			60.0		
	オフセット			オフセット			オフセット			オフセット			オフセット		
	0°	20°	40°	0°	20°	40°	0°	20°	40°	0°	20°	40°	0°	20°	40°
12.0	24.7														
14.0	24.7			21.4			16.6								
16.0	24.7			21.4			16.6			12.7					
18.0	24.3			21.4			16.6			12.7			10.4		
20.0	23.0	14.4		21.4			16.1			12.7			10.0		
22.0	21.7	13.6		21.1	14.0		15.1	11.3		12.7			9.6		
24.0	20.1	12.9		20.1	13.3		14.1	10.8		12.4	9.8		9.2		
26.0	18.6	12.3	9.3	19.2	12.7		13.3	10.3		11.7	9.4		8.8	9.0	
28.0	17.3	11.7	9.0	18.4	12.1	9.1	12.6	9.9		11.0	8.9		8.3	8.6	
30.0	16.1	11.2	8.7	17.4	11.6	8.9	12.0	9.5	8.1	10.4	8.5	7.4	7.9	8.2	
32.0	15.1	10.7	8.5	16.3	11.2	8.6	11.4	9.1	7.8	9.9	8.1	7.1	7.4	7.7	6.5
34.0	14.2	10.3	8.3	15.3	10.7	8.4	10.8	8.7	7.6	9.4	7.8	6.9	7.0	7.3	6.2
36.0	13.4	9.9	8.1	14.4	10.3	8.2	10.3	8.4	7.3	8.9	7.5	6.6	6.6	6.8	5.9
38.0	12.6	9.6	7.9	13.4	10.0	8.1	9.9	8.1	7.1	8.5	7.2	6.4	6.1	6.5	5.7
40.0	12.0	9.2	7.7	12.5	9.6	7.9	9.5	7.8	6.9	8.1	6.9	6.2	5.8	6.1	5.4
42.0	11.4	8.9	7.6	11.7	9.3	7.7	9.1	7.6	6.7	7.8	6.7	6.0	5.4	5.8	5.1
44.0	10.8	8.6	7.5	11.0	9.0	7.6	8.7	7.3	6.6	7.5	6.4	5.8	5.0	5.5	4.9
46.0	10.3	8.4	7.4	10.3	8.7	7.5	8.4	7.1	6.4	7.2	6.2	5.6	4.7	5.1	4.7
48.0	9.8	8.1	7.3	9.6	8.5	7.4	8.1	6.9	6.3	6.9	6.0	5.5	4.4	4.8	4.5
50.0	9.4	7.9	7.2	9.1	8.3	7.3	7.8	6.7	6.1	6.6	5.8	5.3	4.1	4.4	4.3
54.0	8.6	7.6	7.2	8.0	7.9	7.2	7.3	6.4	5.9	6.1	5.4	5.0	3.5	3.9	3.9
58.0	7.7	7.3		7.1	7.0	7.1	6.8	6.1	5.7	5.7	5.1	4.8	3.0	3.4	3.4
62.0	4.7			6.3	6.3		6.0	5.8	5.5	5.3	4.8	4.5	2.5	2.9	3.0
66.0				4.6	5.6		5.3	5.3		4.9	4.4	4.3	2.1	2.5	2.6
70.0							4.3	4.7		4.5	4.2		1.8	2.1	
74.0										3.9	3.9		1.5	1.8	
78.0														1.6	
θ(°)	16~ 83	33~ 84.5	45~ 84.5	19~ 83	25~ 84.5	45~ 84.5	21~ 83	27~ 84.5	45~ 84.5	23~ 83	29~ 84.5	45~ 84.5	30~ 83	30~ 84.5	50~ 84.5
標準フック	35t						35t								
フック重量	950kg						950kg								
標準巻掛本数	3						2								

PS+油圧チルトジブ

カウンタウエイト 118t、アウトリガ張出幅 8.5m

PS+ブーム+2.0m+29.5m油圧チルトジブ

単位:t

ブーム長さ(m) 作業半径 (m)	40.4			45.4			50.5			55.6			60.0		
	オフセット			オフセット			オフセット			オフセット			オフセット		
	0°	20°	40°	0°	20°	40°	0°	20°	40°	0°	20°	40°	0°	20°	40°
14.0	18.7			16.1											
16.0	18.7			16.1			12.4								
18.0	18.7			16.1			12.4						7.0		
20.0	18.7			16.1			12.4			8.7			6.7		
22.0	17.8			16.1			12.4			8.7			6.3		
24.0	16.5	10.2		16.1	10.5		12.4			8.7			6.0		
26.0	15.2	9.6		15.7	9.9		11.8	8.9		8.6			5.6		
28.0	14.1	9.1		15.1	9.4		11.1	8.5		8.4	8.0		5.3		
30.0	13.1	8.7		14.1	9.0		10.5	8.1		8.3	7.6		4.9	6.7	
32.0	12.2	8.3	6.2	13.1	8.6	6.3	10.0	7.8		8.1	7.3		4.6	6.3	
34.0	11.4	7.9	6.0	12.3	8.2	6.1	9.5	7.5	6.2	7.9	6.9		4.2	5.9	
36.0	10.7	7.6	5.9	11.5	7.9	6.0	9.0	7.2	6.0	7.7	6.6	5.8	3.9	5.5	
38.0	10.0	7.2	5.7	10.9	7.5	5.8	8.6	6.9	5.9	7.5	6.4	5.6	3.5	5.2	4.4
40.0	9.5	6.9	5.5	10.2	7.2	5.6	8.2	6.6	5.7	7.3	6.1	5.4	3.2	4.9	4.2
42.0	8.9	6.7	5.4	9.7	7.0	5.5	7.8	6.4	5.6	7.0	5.8	5.2	2.9	4.6	4.0
44.0	8.5	6.4	5.3	9.2	6.7	5.4	7.5	6.2	5.4	6.7	5.6	5.0	2.6	4.3	3.8
46.0	8.0	6.2	5.1	8.7	6.5	5.2	7.2	6.0	5.2	6.4	5.4	4.8	2.3	4.1	3.6
48.0	7.6	6.0	5.0	8.3	6.3	5.1	6.9	5.8	5.1	6.1	5.2	4.6	2.1	3.9	3.4
50.0	7.2	5.8	5.0	7.9	6.1	5.0	6.7	5.6	5.0	5.9	5.0	4.4	1.8	3.6	3.3
54.0	6.6	5.4	4.8	7.1	5.7	4.9	6.2	5.2	4.7	5.3	4.5	4.0		3.2	3.0
58.0	6.0	5.1	4.8	6.3	5.4	4.8	5.8	4.9	4.4	4.8	4.1	3.7		2.7	2.7
62.0	5.5	4.9		5.5	5.1	4.7	5.2	4.6	4.2	4.3	3.8	3.4		2.3	2.4
66.0	5.1	4.8		4.9	4.9		4.6	4.3	4.0	3.9	3.4	3.2		1.9	2.0
70.0				4.3	4.3		4.0	4.0		3.6	3.2	3.0		1.6	1.7
74.0							3.5	3.5		3.1	2.9				
78.0										2.7	2.8				
82.0										1.8	2.4				
θ(°)	21~ 83	29~ 84.5	49~ 84.5	23~ 83	31~ 84.5	49~ 84.5	25~ 83	32~ 84.5	49~ 84.5	19~ 83	26~ 84.5	49~ 84.5	59~ 83	49~ 84.5	53~ 84.5
標準フック	35t											12.2t			
フック重量	950kg											440kg			
標準巻掛本数	2											1			

カウンタウエイト 118t、アウトリガ張出幅 8.5m

PS+ブーム+2.0m+35.5m油圧チルトジブ

単位:t

ブーム長さ(m) 作業半径 (m)	40.4			45.4			50.5			55.6			60.0		
	オフセット			オフセット			オフセット			オフセット			オフセット		
	0°	20°	40°	0°	20°	40°	0°	20°	40°	0°	20°	40°	0°	20°	40°
14.0	14.1														
16.0	14.1			12.2											
18.0	14.1			12.2			8.8								
20.0	14.1			12.2			8.8			6.1			4.4		
22.0	14.1			12.2			8.8			6.1			4.2		
24.0	13.9			12.2			8.8			6.1			3.8		
26.0	13.0	7.9		12.2			8.8			6.0			3.5		
28.0	12.0	7.5		12.2	7.7		8.8			5.8			3.2		
30.0	11.1	7.1		11.8	7.3		8.8	7.4		5.7			2.9		
32.0	10.3	6.7		11.1	6.9		8.8	7.1		5.5	6.5		2.6	5.4	
34.0	9.6	6.4		10.3	6.6		8.8	6.8		5.3	6.2		2.2	5.0	
36.0	8.9	6.1	4.5	9.7	6.3		8.3	6.5		5.2	5.9		1.9	4.7	
38.0	8.4	5.8	4.3	9.0	6.0	4.4	7.9	6.2		5.0	5.6		1.6	4.4	
40.0	7.9	5.5	4.2	8.5	5.7	4.2	7.5	6.0	4.5	4.8	5.4			4.1	
42.0	7.4	5.3	4.0	8.0	5.5	4.1	7.2	5.7	4.4	4.6	5.1	4.4		3.9	3.3
44.0	7.0	5.0	3.9	7.5	5.3	4.0	6.9	5.5	4.3	4.3	4.9	4.2		3.6	3.1
46.0	6.6	4.8	3.8	7.1	5.0	3.9	6.6	5.3	4.1	4.1	4.6	4.0		3.4	2.9
48.0	6.2	4.6	3.7	6.7	4.8	3.7	6.3	5.1	4.0	3.9	4.3	3.8		3.2	2.7
50.0	5.9	4.4	3.6	6.4	4.7	3.7	6.0	4.9	3.9	3.7	4.1	3.6		3.0	2.6
54.0	5.3	4.1	3.4	5.8	4.3	3.5	5.6	4.5	3.7	3.2	3.7	3.2		2.6	2.3
58.0	4.8	3.8	3.3	5.2	4.0	3.3	5.0	4.1	3.6	2.7	3.3	2.9		2.3	2.0
62.0	4.3	3.6	3.2	4.7	3.8	3.2	4.6	3.8	3.4	2.3	3.0	2.6		1.9	1.8
66.0	4.0	3.4	3.2	4.3	3.6	3.2	4.2	3.5	3.2	1.8	2.7	2.4			1.6
70.0	3.6	3.3		3.8	3.4	3.2	3.6	3.3	3.0		2.4	2.2			
74.0	2.2			3.3	3.3		3.1	3.1	2.9		2.2	2.0			
78.0				2.1	2.9		2.6	2.7			2.0	1.8			
82.0							2.2	2.3							
86.0										1.8					
θ(°)	14~ 83	34~ 84.5	46~ 84.5	18~ 83	26~ 84.5	47~ 84.5	21~ 83	29~ 84.5	47~ 84.5	47~ 83	32~ 84.5	48~ 84.5	70~ 83	61~ 84.5	63~ 84.5
標準フック	35t											12.2t			
フック重量	950kg											440kg			
標準巻掛本数	2											1			

カウンタウエイト 118t、アウトリガ張出幅 8.5m

PS+ブーム+2.0m+41.5m油圧チルトジブ

単位:t

ブーム長さ(m) 作業半径 (m)	40.4			45.4			50.5			55.6			60.0		
	オフセット			オフセット			オフセット			オフセット			オフセット		
	0°	20°	40°	0°	20°	40°	0°	20°	40°	0°	20°	40°	0°	20°	40°
16.0	10.1			8.6											
18.0	10.1			8.6			6.0								
20.0	10.1			8.6			6.0					3.5			
22.0	10.1			8.6			6.0				3.5			1.9	
24.0	10.1			8.6			6.0				3.5			1.6	
26.0	10.1			8.6			6.0				3.4				
28.0	10.1			8.6			6.0				3.2				
30.0	9.5	5.8		8.6			6.0				3.1				
32.0	8.8	5.4		8.6	5.6		6.0				2.9				
34.0	8.2	5.1		8.6	5.3		6.0	5.4			2.8				
36.0	7.6	4.8		8.2	5.0		6.0	5.1			2.6	4.8			3.1
38.0	7.0	4.5		7.6	4.7		6.0	4.9			2.4	4.6			3.1
40.0	6.5	4.2		7.1	4.4		6.0	4.6			2.2	4.3			3.1
42.0	6.1	4.0	2.8	6.6	4.2		6.0	4.4			2.0	4.0			2.9
44.0	5.7	3.8	2.6	6.2	4.0	2.7	5.9	4.1			1.8	3.7			2.7
46.0	5.3	3.6	2.5	5.8	3.8	2.6	5.6	3.9	2.6		1.6	3.5			2.5
48.0	4.9	3.4	2.4	5.4	3.6	2.5	5.3	3.7	2.5		3.2	2.6			2.3
50.0	4.6	3.2	2.3	5.1	3.4	2.4	5.0	3.6	2.4		3.0	2.5			2.1
54.0	4.1	2.9	2.1	4.5	3.1	2.2	4.4	3.2	2.3		2.6	2.2			1.7
58.0	3.6	2.6	2.0	4.0	2.8	2.0	3.9	2.9	2.1		2.3	1.9			
62.0	3.2	2.3	1.8	3.5	2.5	1.9	3.5	2.7	2.0		1.9	1.6			
66.0	2.8	2.1	1.7	3.1	2.3	1.8	3.1	2.4	1.8		1.6				
70.0	2.5	1.9	1.7	2.8	2.1	1.7	2.7	2.1	1.8						
74.0	2.2	1.8		2.5	1.9	1.7	2.3	1.9	1.6						
78.0	1.9	1.7		2.1	1.8		1.8	1.7	1.5						
82.0				1.7	1.7			1.5							
θ (°)	20~ 83	30~ 84.5	51~ 84.5	23~ 83	32~ 84.5	51~ 84.5	35~ 83	40~ 84.5	51~ 84.5	65~ 83	60~ 84.5	70~ 84.5	80~ 83	70~ 84.5	80~ 84.5
標準フック	12.2t														
フック重量	440kg														
標準巻掛本数	1														

カウンタウエイト 118t、アウトリガ張出幅 8.5m

PS+ブーム+2.0m+47.5m油圧チルトジブ

単位:t

ブーム長さ(m) 作業半径 (m)	40.4		45.4		50.5	
	オフセット		オフセット		オフセット	
	0°	20°	0°	20°	0°	20°
16.0	6.7					
18.0	6.7		5.6			
20.0	6.7		5.6		3.3	
22.0	6.7		5.6		3.3	
24.0	6.7		5.6		3.3	
26.0	6.7		5.6		3.3	
28.0	6.7		5.6		3.3	
30.0	6.7		5.6		3.3	
32.0	6.7		5.6		3.3	
34.0	6.4	3.7	5.6		3.3	
36.0	5.9	3.5	5.6	3.6	3.3	
38.0	5.4	3.2	5.6	3.4	3.3	3.5
40.0	5.0	3.0	5.4	3.1	3.3	3.3
42.0	4.6	2.8	5.0	2.9	3.3	3.1
44.0	4.3	2.6	4.7	2.7	3.3	2.9
46.0	4.0	2.4	4.3	2.6	3.3	2.7
48.0	3.7	2.3	4.0	2.4	3.3	2.5
50.0	3.4	2.1	3.7	2.2	3.3	2.4
54.0	2.9	1.8	3.2	1.9	3.3	2.1
58.0	2.5	1.6	2.8	1.7	2.9	1.8
62.0	2.1		2.4	1.5	2.5	1.6
66.0	1.8		2.1		2.2	
70.0	1.5		1.8		1.8	
74.0			1.5		1.5	
θ (°)	40~ 84.5	62~ 84.5	40~ 84.5	62~ 84.5	44~ 84.5	65~ 84.5
標準フック	12.2t					
フック重量	440kg					
標準巻掛本数	1					

PS+油圧チルトジブ

カウンタウエイト 118t、アウトリガ張出幅 8.0m

PS+ブーム+2.0m+3.5m油圧チルトジブ

単位:t

ブーム長さ(m) 作業半径 (m)	40.4			45.4			50.5			55.6			60.0		
	オフセット			オフセット			オフセット			オフセット			オフセット		
	0°	20°	40°	0°	20°	40°	0°	20°	40°	0°	20°	40°	0°	20°	40°
8.0	58.6														
9.0	58.6	58.6		52.9											
10.0	58.6	58.6	53.9	52.0	48.4		34.9								
11.0	58.6	57.7	52.9	50.7	47.2	45.0	33.7	30.3		28.3					
12.0	58.6	56.5	51.9	49.5	46.2	44.1	32.6	29.4	27.4	27.3	25.1		26.0		
14.0	56.8	54.2	50.2	47.3	44.4	42.5	30.6	27.8	26.1	25.5	23.6	22.4	24.3	22.5	21.4
16.0	50.2	48.4	47.2	45.4	42.8	41.1	28.9	26.4	24.9	23.9	22.2	21.2	22.8	21.3	20.3
18.0	44.8	43.4	42.5	42.5	41.1	39.9	27.4	25.2	23.9	22.5	21.1	20.1	21.5	20.2	19.3
20.0	40.3	39.2	38.6	38.3	37.2	36.5	26.1	24.1	22.9	21.3	20.0	19.2	20.4	19.2	18.4
22.0	36.5	35.7	35.2	34.7	33.8	33.3	24.9	23.1	22.1	20.2	19.1	18.4	19.4	18.3	17.6
24.0	33.3	32.7	32.3	31.6	30.9	30.6	23.8	22.3	21.4	19.3	18.2	17.6	18.5	17.5	16.9
26.0	30.6	30.1	29.8	29.0	28.4	28.2	22.9	21.5	20.7	18.4	17.5	16.9	17.6	16.8	16.2
28.0	28.2	27.7	27.6	26.7	26.3	26.0	22.1	20.8	20.1	17.6	16.8	16.3	16.8	16.1	15.6
30.0	26.0	25.7	25.6	24.7	24.3	24.2	21.3	20.1	19.5	16.9	16.1	15.7	15.6	15.2	14.9
32.0	24.2	23.9	23.8	22.9	22.6	22.5	20.6	19.5	19.0	16.2	15.6	15.2	14.5	14.1	13.9
34.0	21.9	22.1	22.2	21.3	21.1	21.0	20.0	19.0	18.6	15.7	15.0	14.7	13.5	13.2	13.0
36.0	19.8	19.9		19.8	19.7	19.6	19.4	18.6	18.2	15.1	14.6	14.3	12.6	12.3	12.2
38.0	17.9	18.0		18.3	18.4	18.4	18.1	18.0	17.9	14.6	14.1	13.9	11.8	11.6	11.5
40.0	16.1	16.3		16.6	16.8		17.0	16.8	16.8	14.2	13.7	13.5	11.0	10.9	10.8
42.0	12.2			15.1	15.2		15.8	15.9	15.8	13.8	13.4	13.2	10.4	10.2	10.2
44.0	3.8			13.8	13.9		14.4	14.6		13.4	13.0	12.9	9.7	9.6	9.6
46.0				11.5	11.7		13.2	13.3		13.1	12.7	12.7	9.2	9.1	9.1
48.0				7.4			12.0	12.1		12.6	12.5		8.7	8.6	8.6
50.0							10.8	10.9		11.5	11.6		8.2	8.1	
54.0							2.5			9.5	9.5		7.1	7.2	
58.0										4.9			6.1	6.2	
62.0													4.4		
θ(°)	0~ 84.5	27~ 84.5	43~ 84.5	13~ 84.5	23~ 84.5	42~ 84.5	0~ 84.5	25~ 84.5	42~ 84.5	13~ 84.5	27~ 84.5	42~ 84.5	15~ 84.5	27~ 84.5	45~ 84.5
標準フック	80t						35t								
フック重量	1550kg						950kg								
標準巻掛本数	5						3								

カウンタウエイト 118t、アウトリガ張出幅 8.0m

PS+ブーム+2.0m+11.5m油圧チルトジブ

単位:t

ブーム長さ(m) 作業半径 (m)	40.4			45.4			50.5			55.6			60.0		
	オフセット			オフセット			オフセット			オフセット			オフセット		
	0°	20°	40°	0°	20°	40°	0°	20°	40°	0°	20°	40°	0°	20°	40°
10.0	45.4														
11.0	45.4			36.6											
12.0	44.8			36.6			27.9								
14.0	42.2	32.1		36.6	30.8		25.8			22.3			19.5		
16.0	39.8	30.6	24.5	36.6	29.6		24.0	19.0		20.7	17.0		19.5		
18.0	37.6	29.3	23.9	36.1	28.4	24.2	22.5	18.0	15.5	19.3	16.0		18.4	15.4	
20.0	35.3	28.1	23.3	33.9	27.4	23.5	21.1	17.1	14.9	18.1	15.2	13.5	17.3	14.6	
22.0	32.0	27.1	22.8	30.6	26.4	22.8	19.9	16.4	14.3	17.0	14.4	12.9	16.3	13.9	12.4
24.0	29.2	26.1	22.3	27.9	25.6	22.3	18.8	15.7	13.8	16.1	13.7	12.4	15.4	13.2	11.9
26.0	26.7	25.3	21.9	25.5	24.1	21.8	17.9	15.0	13.4	15.2	13.1	11.9	14.6	12.6	11.4
28.0	24.6	23.5	21.5	23.5	22.3	21.3	17.1	14.4	12.9	14.4	12.6	11.4	13.9	12.1	11.0
30.0	22.7	21.8	21.2	21.7	20.7	20.2	16.3	13.9	12.5	13.7	12.0	11.0	13.1	11.6	10.6
32.0	21.1	20.3	19.9	20.1	19.3	18.9	15.6	13.4	12.2	13.1	11.6	10.6	12.1	11.1	10.3
34.0	19.6	19.0	18.7	18.6	18.0	17.6	15.0	13.0	11.9	12.5	11.1	10.3	11.2	10.5	9.9
36.0	18.3	17.8	17.5	17.4	16.8	16.5	14.4	12.6	11.6	12.0	10.7	10.0	10.4	9.8	9.5
38.0	17.1	16.7	16.5	16.2	15.8	15.6	13.9	12.2	11.3	11.5	10.3	9.7	9.7	9.2	8.9
40.0	16.0	15.7	15.5	15.1	14.8	14.6	13.4	11.9	11.0	11.1	10.0	9.4	9.0	8.6	8.4
42.0	15.0	14.8	14.7	14.2	13.9	13.8	12.9	11.5	10.8	10.7	9.7	9.1	8.4	8.1	7.9
44.0	14.1	13.9		13.3	13.1	13.0	12.5	11.3	10.6	10.3	9.4	8.9	7.9	7.6	7.4
46.0	13.2	13.1		12.5	12.3	12.3	12.2	11.0	10.4	10.0	9.1	8.7	7.4	7.1	7.0
48.0	11.4	12.3		11.8	11.6		11.5	10.8	10.3	9.6	8.9	8.5	6.9	6.7	6.6
50.0	8.3			11.1	11.0		10.8	10.6	10.2	9.3	8.6	8.3	6.5	6.3	6.3
54.0				8.0	9.2		9.5	9.5		8.8	8.2	8.0	5.7	5.6	5.6
58.0							7.5	8.1		8.3	7.9		5.1	5.0	
62.0										6.8	7.0		4.5	4.5	
66.0										2.7			4.0	4.0	
70.0													2.4		
θ(°)	17~ 83	28~ 84.5	44~ 84.5	20~ 83	24~ 84.5	44~ 84.5	22~ 83	26~ 84.5	43~ 84.5	12~ 83	28~ 84.5	43~ 84.5	14~ 83	28~ 84.5	48~ 84.5
標準フック	80t						35t								
フック重量	1550kg						950kg								
標準巻掛本数	4						3								

カウンタウエイト 118t、アウトリガ張出幅 8.0m

PS+ブーム+2.0m+17.5m油圧チルトジブ

単位:t

ブーム長さ(m) 作業半径 (m)	40.4			45.4			50.5			55.6			60.0		
	オフセット			オフセット			オフセット			オフセット			オフセット		
	0°	20°	40°	0°	20°	40°	0°	20°	40°	0°	20°	40°	0°	20°	40°
11.0	32.6														
12.0	32.6			28.2											
14.0	32.6			28.2			21.7								
16.0	31.2	21.3		28.2			21.0			16.9			14.4		
18.0	29.4	20.2		28.1	20.7		19.6	14.9		16.9			14.0		
20.0	27.9	19.2		26.9	19.8		18.3	14.1		15.9	12.7		13.6		
22.0	26.5	18.3	14.0	25.6	18.9		17.2	13.4		14.9	12.1		13.1	11.6	
24.0	25.2	17.5	13.6	24.5	18.0	13.8	16.2	12.8	11.0	14.0	11.5		12.7	11.1	
26.0	24.0	16.7	13.3	23.2	17.3	13.5	15.3	12.3	10.6	13.2	10.9	9.6	12.1	10.6	9.3
28.0	22.4	16.1	12.9	21.3	16.6	13.1	14.5	11.8	10.2	12.5	10.4	9.2	11.6	10.1	8.9
30.0	20.7	15.4	12.7	19.7	16.0	12.9	13.8	11.3	9.9	11.9	10.0	8.9	11.1	9.7	8.6
32.0	19.2	14.9	12.4	18.2	15.5	12.6	13.2	10.9	9.6	11.3	9.6	8.6	10.6	9.3	8.3
34.0	17.8	14.4	12.2	16.9	15.0	12.4	12.6	10.5	9.3	10.8	9.2	8.3	9.8	8.9	8.0
36.0	16.6	13.9	12.0	15.8	14.5	12.2	12.1	10.1	9.1	10.3	8.8	8.0	9.1	8.4	7.6
38.0	15.5	13.5	11.8	14.7	14.0	12.0	11.6	9.8	8.8	9.8	8.5	7.8	8.4	7.8	7.3
40.0	14.5	13.1	11.7	13.7	13.3	11.8	11.1	9.5	8.6	9.4	8.2	7.5	7.8	7.3	7.0
42.0	13.6	12.8	11.6	12.8	12.5	11.7	10.7	9.2	8.4	9.0	7.9	7.3	7.3	6.9	6.7
44.0	12.8	12.5	11.5	12.0	11.8	11.6	10.3	9.0	8.2	8.7	7.7	7.1	6.7	6.4	6.3
46.0	12.0	11.8	11.5	11.3	11.1	11.0	10.0	8.7	8.0	8.4	7.4	6.9	6.3	6.0	5.9
48.0	11.3	11.2	11.1	10.6	10.4	10.4	9.7	8.5	7.9	8.1	7.2	6.7	5.9	5.6	5.6
50.0	10.7	10.6		10.0	9.9	9.8	9.4	8.3	7.8	7.8	7.0	6.6	5.5	5.3	5.3
54.0	9.0	9.5		8.9	8.8		8.6	7.9	7.5	7.3	6.6	6.3	4.8	4.7	4.7
58.0				7.9	7.9		7.7	7.6		6.8	6.3	6.0	4.2	4.1	4.2
62.0				3.2			6.8	6.8		6.5	6.0		3.6	3.6	3.7
66.0							3.8			5.7	5.8		3.2	3.2	
70.0										3.9	4.8		2.8	2.8	
74.0													2.5	2.5	
θ (°)	23~ 83	28~ 84.5	44~ 84.5	11~ 83	30~ 84.5	48~ 84.5	16~ 83	31~ 84.5	47~ 84.5	19~ 83	23~ 84.5	47~ 84.5	20~ 83	24~ 84.5	46~ 84.5
標準フック	35t						35t								
フック重量	950kg						950kg								
標準巻掛本数	3						2								

カウンタウエイト 118t、アウトリガ張出幅 8.0m

PS+ブーム+2.0m+23.5m油圧チルトジブ

単位:t

ブーム長さ(m) 作業半径 (m)	40.4			45.4			50.5			55.6			60.0		
	オフセット			オフセット			オフセット			オフセット			オフセット		
	0°	20°	40°	0°	20°	40°	0°	20°	40°	0°	20°	40°	0°	20°	40°
12.0	24.7														
14.0	24.7			21.4			16.6								
16.0	24.7			21.4			16.6			12.7					
18.0	24.3			21.4			16.6			12.7			10.4		
20.0	23.0	14.4		21.4			16.1			12.7			10.0		
22.0	21.7	13.6		21.1	14.0		15.1	11.3		12.7			9.6		
24.0	20.1	12.9		20.1	13.3		14.1	10.8		12.4	9.8		9.2		
26.0	18.6	12.3	9.3	19.2	12.7		13.3	10.3		11.7	9.4		8.8	9.0	
28.0	17.3	11.7	9.0	18.4	12.1	9.1	12.6	9.9		11.0	8.9		8.3	8.6	
30.0	16.1	11.2	8.7	17.4	11.6	8.9	12.0	9.5	8.1	10.4	8.5	7.4	7.9	8.2	
32.0	15.1	10.7	8.5	16.3	11.2	8.6	11.4	9.1	7.8	9.9	8.1	7.1	7.4	7.7	6.5
34.0	14.2	10.3	8.3	15.3	10.7	8.4	10.8	8.7	7.6	9.4	7.8	6.9	7.0	7.3	6.2
36.0	13.4	9.9	8.1	14.4	10.3	8.2	10.3	8.4	7.3	8.9	7.5	6.6	6.6	6.8	5.9
38.0	12.6	9.6	7.9	13.4	10.0	8.1	9.9	8.1	7.1	8.5	7.2	6.4	6.1	6.5	5.7
40.0	12.0	9.2	7.7	12.5	9.6	7.9	9.5	7.8	6.9	8.1	6.9	6.2	5.8	6.1	5.4
42.0	11.4	8.9	7.6	11.7	9.3	7.7	9.1	7.6	6.7	7.8	6.7	6.0	5.4	5.8	5.1
44.0	10.8	8.6	7.5	11.0	9.0	7.6	8.7	7.3	6.6	7.5	6.4	5.8	5.0	5.5	4.9
46.0	10.3	8.4	7.4	10.3	8.7	7.5	8.4	7.1	6.4	7.2	6.2	5.6	4.7	5.1	4.7
48.0	9.8	8.1	7.3	9.6	8.5	7.4	8.1	6.9	6.3	6.9	6.0	5.5	4.4	4.8	4.5
50.0	9.4	7.9	7.2	9.1	8.3	7.3	7.8	6.7	6.1	6.6	5.8	5.3	4.1	4.4	4.3
54.0	8.6	7.6	7.2	8.0	7.9	7.2	7.3	6.4	5.9	6.1	5.4	5.0	3.5	3.9	3.9
58.0	7.7	7.3		7.1	7.0	7.1	6.8	6.1	5.7	5.7	5.1	4.8	3.0	3.4	3.4
62.0	4.7			6.3	6.3		6.0	5.8	5.5	5.3	4.8	4.5	2.5	2.9	3.0
66.0				4.6	5.6		5.3	5.3		4.9	4.4	4.3	2.1	2.5	2.6
70.0							4.3	4.7		4.5	4.2		1.8	2.1	
74.0										3.7	3.9		1.5	1.8	
78.0														1.6	
θ (°)	16~ 83	33~ 84.5	45~ 84.5	19~ 83	25~ 84.5	45~ 84.5	21~ 83	27~ 84.5	45~ 84.5	23~ 83	29~ 84.5	45~ 84.5	30~ 83	30~ 84.5	50~ 84.5
標準フック	35t						35t								
フック重量	950kg						950kg								
標準巻掛本数	3						2								

PS+油圧チルトジブ

カウンタウエイト 118t、アウトリガ張出幅 8.0m

PS+ブーム+2.0m+29.5m油圧チルトジブ

単位:t

ブーム長さ(m) 作業半径 (m)	40.4			45.4			50.5			55.6			60.0		
	オフセット			オフセット			オフセット			オフセット			オフセット		
	0°	20°	40°	0°	20°	40°	0°	20°	40°	0°	20°	40°	0°	20°	40°
14.0	18.7			16.1											
16.0	18.7			16.1			12.4								
18.0	18.7			16.1			12.4							7.0	
20.0	18.7			16.1			12.4				8.7			6.7	
22.0	17.8			16.1			12.4				8.7			6.3	
24.0	16.5	10.2		16.1	10.5		12.4				8.7			6.0	
26.0	15.2	9.6		15.7	9.9		11.8	8.9			8.6			5.6	
28.0	14.1	9.1		15.1	9.4		11.1	8.5			8.4	8.0		5.3	
30.0	13.1	8.7		14.1	9.0		10.5	8.1			8.3	7.6		4.9	6.7
32.0	12.2	8.3	6.2	13.1	8.6	6.3	10.0	7.8			8.1	7.3		4.6	6.3
34.0	11.4	7.9	6.0	12.3	8.2	6.1	9.5	7.5	6.2		7.9	6.9		4.2	5.9
36.0	10.7	7.6	5.9	11.5	7.9	6.0	9.0	7.2	6.0	7.7	6.6	5.8		3.9	5.5
38.0	10.0	7.2	5.7	10.9	7.5	5.8	8.6	6.9	5.9	7.5	6.4	5.6		3.5	5.2 4.4
40.0	9.5	6.9	5.5	10.2	7.2	5.6	8.2	6.6	5.7	7.3	6.1	5.4		3.2	4.9 4.2
42.0	8.9	6.7	5.4	9.7	7.0	5.5	7.8	6.4	5.6	7.0	5.8	5.2		2.9	4.6 4.0
44.0	8.5	6.4	5.3	9.2	6.7	5.4	7.5	6.2	5.4	6.7	5.6	5.0		2.6	4.3 3.8
46.0	8.0	6.2	5.1	8.7	6.5	5.2	7.2	6.0	5.2	6.4	5.4	4.8		2.3	4.1 3.6
48.0	7.6	6.0	5.0	8.3	6.3	5.1	6.9	5.8	5.1	6.1	5.2	4.6		2.1	3.9 3.4
50.0	7.2	5.8	5.0	7.9	6.1	5.0	6.7	5.6	5.0	5.9	5.0	4.4		1.8	3.6 3.3
54.0	6.6	5.4	4.8	7.1	5.7	4.9	6.2	5.2	4.7	5.3	4.5	4.0			3.2 3.0
58.0	6.0	5.1	4.8	6.3	5.4	4.8	5.8	4.9	4.4	4.8	4.1	3.7			2.7 2.7
62.0	5.5	4.9		5.5	5.1	4.7	5.2	4.6	4.2	4.3	3.8	3.4			2.3 2.4
66.0	5.1	4.8		4.9	4.9		4.6	4.3	4.0	3.9	3.4	3.2			1.9 2.0
70.0				4.3	4.3		4.0	4.0		3.6	3.2	3.0			1.6 1.7
74.0							3.5	3.5		3.1	2.9				
78.0										2.7	2.8				
82.0										1.8	2.4				
θ(°)	21~ 83	29~ 84.5	49~ 84.5	23~ 83	31~ 84.5	49~ 84.5	25~ 83	32~ 84.5	49~ 84.5	19~ 83	26~ 84.5	49~ 84.5	59~ 83	49~ 84.5	53~ 84.5
標準フック	35t											12.2t			
フック重量	950kg											440kg			
標準巻掛本数	2											1			

カウンタウエイト 118t、アウトリガ張出幅 8.0m

PS+ブーム+2.0m+35.5m油圧チルトジブ

単位:t

ブーム長さ(m) 作業半径 (m)	40.4			45.4			50.5			55.6			60.0		
	オフセット			オフセット			オフセット			オフセット			オフセット		
	0°	20°	40°	0°	20°	40°	0°	20°	40°	0°	20°	40°	0°	20°	40°
14.0	14.1														
16.0	14.1			12.2											
18.0	14.1			12.2			8.8								
20.0	14.1			12.2			8.8				6.1			4.4	
22.0	14.1			12.2			8.8				6.1			4.2	
24.0	13.9			12.2			8.8				6.1			3.8	
26.0	13.0	7.9		12.2			8.8				6.0			3.5	
28.0	12.0	7.5		12.2	7.7		8.8				5.8			3.2	
30.0	11.1	7.1		11.8	7.3		8.8	7.4			5.7			2.9	
32.0	10.3	6.7		11.1	6.9		8.8	7.1			5.5	6.5		2.6	5.4
34.0	9.6	6.4		10.3	6.6		8.8	6.8			5.3	6.2		2.2	5.0
36.0	8.9	6.1	4.5	9.7	6.3		8.3	6.5			5.2	5.9		1.9	4.7
38.0	8.4	5.8	4.3	9.0	6.0	4.4	7.9	6.2			5.0	5.6		1.6	4.4
40.0	7.9	5.5	4.2	8.5	5.7	4.2	7.5	6.0	4.5		4.8	5.4			4.1
42.0	7.4	5.3	4.0	8.0	5.5	4.1	7.2	5.7	4.4	4.6	5.1	4.4			3.9 3.3
44.0	7.0	5.0	3.9	7.5	5.3	4.0	6.9	5.5	4.3	4.3	4.9	4.2			3.6 3.1
46.0	6.6	4.8	3.8	7.1	5.0	3.9	6.6	5.3	4.1	4.1	4.6	4.0			3.4 2.9
48.0	6.2	4.6	3.7	6.7	4.8	3.7	6.3	5.1	4.0	3.9	4.3	3.8			3.2 2.7
50.0	5.9	4.4	3.6	6.4	4.7	3.7	6.0	4.9	3.9	3.7	4.1	3.6			3.0 2.6
54.0	5.3	4.1	3.4	5.8	4.3	3.5	5.6	4.5	3.7	3.2	3.7	3.2			2.6 2.3
58.0	4.8	3.8	3.3	5.2	4.0	3.3	5.0	4.1	3.6	2.7	3.3	2.9			2.3 2.0
62.0	4.3	3.6	3.2	4.7	3.8	3.2	4.6	3.8	3.4	2.3	3.0	2.6			1.9 1.8
66.0	4.0	3.4	3.2	4.3	3.6	3.2	4.2	3.5	3.2	1.8	2.7	2.4			1.6
70.0	3.6	3.3		3.8	3.4	3.2	3.6	3.3	3.0		2.4	2.2			
74.0	2.2			3.3	3.3		3.1	3.1	2.9		2.2	2.0			
78.0				2.1	2.9		2.6	2.7			2.0	1.8			
82.0							2.2	2.3			1.8				
86.0											1.6				
θ(°)	14~ 83	34~ 84.5	46~ 84.5	18~ 83	26~ 84.5	47~ 84.5	21~ 83	29~ 84.5	47~ 84.5	47~ 83	32~ 84.5	48~ 84.5	70~ 83	61~ 84.5	63~ 84.5
標準フック	35t											12.2t			
フック重量	950kg											440kg			
標準巻掛本数	2											1			

カウンタウエイト 118t、アウトリガ張出幅 8.0m

PS+ブーム+2.0m+41.5m油圧チルトジブ

単位:t

ブーム長さ(m) 作業半径 (m)	40.4			45.4			50.5			55.6			60.0		
	オフセット			オフセット			オフセット			オフセット			オフセット		
	0°	20°	40°	0°	20°	40°	0°	20°	40°	0°	20°	40°	0°	20°	40°
16.0	10.1			8.6											
18.0	10.1			8.6			6.0								
20.0	10.1			8.6			6.0					3.5			
22.0	10.1			8.6			6.0				3.5			1.9	
24.0	10.1			8.6			6.0				3.5			1.6	
26.0	10.1			8.6			6.0				3.4				
28.0	10.1			8.6			6.0				3.2				
30.0	9.5	5.8		8.6			6.0				3.1				
32.0	8.8	5.4		8.6	5.6		6.0				2.9				
34.0	8.2	5.1		8.6	5.3		6.0	5.4			2.8				
36.0	7.6	4.8		8.2	5.0		6.0	5.1			2.6	4.8			3.1
38.0	7.0	4.5		7.6	4.7		6.0	4.9			2.4	4.6			3.1
40.0	6.5	4.2		7.1	4.4		6.0	4.6			2.2	4.3			3.1
42.0	6.1	4.0	2.8	6.6	4.2		6.0	4.4			2.0	4.0			2.9
44.0	5.7	3.8	2.6	6.2	4.0	2.7	5.9	4.1			1.8	3.7			2.7
46.0	5.3	3.6	2.5	5.8	3.8	2.6	5.6	3.9	2.6		1.6	3.5			2.5
48.0	4.9	3.4	2.4	5.4	3.6	2.5	5.3	3.7	2.5		3.2	2.6			2.3
50.0	4.6	3.2	2.3	5.1	3.4	2.4	5.0	3.6	2.4		3.0	2.5			2.1
54.0	4.1	2.9	2.1	4.5	3.1	2.2	4.4	3.2	2.3		2.6	2.2			1.7
58.0	3.6	2.6	2.0	4.0	2.8	2.0	3.9	2.9	2.1		2.3	1.9			
62.0	3.2	2.3	1.8	3.5	2.5	1.9	3.5	2.7	2.0		1.9	1.6			
66.0	2.8	2.1	1.7	3.1	2.3	1.8	3.1	2.4	1.8		1.6				
70.0	2.5	1.9	1.7	2.8	2.1	1.7	2.7	2.1	1.8						
74.0	2.2	1.8		2.5	1.9	1.7	2.3	1.9	1.6						
78.0	1.9	1.7		2.1	1.8		1.8	1.7	1.5						
82.0				1.7	1.7			1.5							
θ (°)	20~ 83	30~ 84.5	51~ 84.5	23~ 83	32~ 84.5	51~ 84.5	35~ 83	40~ 84.5	51~ 84.5	65~ 83	60~ 84.5	70~ 84.5	80~ 83	70~ 84.5	80~ 84.5
標準フック	12.2t														
フック重量	440kg														
標準巻掛本数	1														

カウンタウエイト 118t、アウトリガ張出幅 8.0m

PS+ブーム+2.0m+47.5m油圧チルトジブ

単位:t

ブーム長さ(m) 作業半径 (m)	40.4		45.4		50.5	
	オフセット		オフセット		オフセット	
	0°	20°	0°	20°	0°	20°
16.0	6.7					
18.0	6.7		5.6			
20.0	6.7		5.6		3.3	
22.0	6.7		5.6		3.3	
24.0	6.7		5.6		3.3	
26.0	6.7		5.6		3.3	
28.0	6.7		5.6		3.3	
30.0	6.7		5.6		3.3	
32.0	6.7		5.6		3.3	
34.0	6.4	3.7	5.6		3.3	
36.0	5.9	3.5	5.6	3.6	3.3	
38.0	5.4	3.2	5.6	3.4	3.3	3.5
40.0	5.0	3.0	5.4	3.1	3.3	3.3
42.0	4.6	2.8	5.0	2.9	3.3	3.1
44.0	4.3	2.6	4.7	2.7	3.3	2.9
46.0	4.0	2.4	4.3	2.6	3.3	2.7
48.0	3.7	2.3	4.0	2.4	3.3	2.5
50.0	3.4	2.1	3.7	2.2	3.3	2.4
54.0	2.9	1.8	3.2	1.9	3.3	2.1
58.0	2.5	1.6	2.8	1.7	2.9	1.8
62.0	2.1		2.4	1.5	2.5	1.6
66.0	1.8		2.1		2.2	
70.0	1.5		1.8		1.8	
74.0			1.5		1.5	
θ (°)	40~ 84.5	62~ 84.5	40~ 84.5	62~ 84.5	44~ 84.5	65~ 84.5
標準フック	12.2t					
フック重量	440kg					
標準巻掛本数	1					

PS+油圧チルトジブ

カウンタウエイト 98t、アウトリガ張出幅 8.5m

PS+ブーム+2.0m+3.5m油圧チルトジブ

単位:t

ブーム長さ(m) 作業半径 (m)	40.4			45.4			50.5			55.6			60.0		
	オフセット			オフセット			オフセット			オフセット			オフセット		
	0°	20°	40°	0°	20°	40°	0°	20°	40°	0°	20°	40°	0°	20°	40°
8.0	58.6														
9.0	58.6	58.6		52.9											
10.0	58.6	58.6	53.9	52.0	48.4		34.9								
11.0	58.6	57.7	52.9	50.7	47.2	45.0	33.7	30.3		28.3					
12.0	58.6	56.5	51.9	49.5	46.2	44.1	32.6	29.4	27.4	27.3	25.1		26.0		
14.0	56.8	54.2	50.2	47.3	44.4	42.5	30.6	27.8	26.1	25.5	23.6	22.4	24.3	22.5	21.4
16.0	50.2	48.4	47.2	45.4	42.8	41.1	28.9	26.4	24.9	23.9	22.2	21.2	22.8	21.3	20.3
18.0	44.8	43.4	42.5	42.5	41.1	39.9	27.4	25.2	23.9	22.5	21.1	20.1	21.5	20.2	19.3
20.0	40.3	39.2	38.6	38.3	37.2	36.5	26.1	24.1	22.9	21.3	20.0	19.2	20.4	19.2	18.4
22.0	36.5	35.7	35.2	34.7	33.8	33.3	24.9	23.1	22.1	20.2	19.1	18.4	19.4	18.3	17.6
24.0	33.3	32.7	32.3	31.6	30.9	30.6	23.8	22.3	21.4	19.3	18.2	17.6	18.5	17.5	16.9
26.0	29.4	29.8	29.8	29.0	28.4	28.2	22.9	21.5	20.7	18.4	17.5	16.9	17.6	16.8	16.2
28.0	25.9	26.3	26.5	26.4	26.3	26.0	22.1	20.8	20.1	17.6	16.8	16.3	16.8	16.1	15.6
30.0	23.0	23.3	23.4	23.5	23.8	23.9	21.3	20.1	19.5	16.9	16.1	15.7	15.6	15.2	14.9
32.0	20.5	20.7	20.8	20.9	21.2	21.4	20.6	19.5	19.0	16.2	15.6	15.2	14.5	14.1	13.9
34.0	18.3	18.5	18.6	18.8	19.0	19.1	19.5	19.0	18.6	15.7	15.0	14.7	13.5	13.2	13.0
36.0	16.4	16.6		16.8	17.1	17.1	17.5	17.8	17.9	15.1	14.6	14.3	12.6	12.3	12.2
38.0	14.7	14.8		15.2	15.3	15.4	15.8	16.0	16.1	14.6	14.1	13.9	11.8	11.6	11.5
40.0	13.1	13.2		13.7	13.8		14.3	14.5	14.6	14.2	13.7	13.5	11.0	10.9	10.8
42.0	11.6			12.2	12.3		13.0	13.1	13.2	13.6	13.4	13.2	10.4	10.2	10.2
44.0	3.8			10.8	10.9		11.7	11.8		12.3	12.5	12.5	9.7	9.6	9.6
46.0				9.6	9.6		10.4	10.5		11.1	11.3	11.3	9.2	9.1	9.1
48.0				7.4			9.3	9.4		10.0	10.1		8.7	8.6	8.6
50.0							8.3	8.3		9.0	9.1		8.2	8.1	
54.0							2.5			7.1	7.2		7.1	7.2	
58.0										4.9			5.7	5.7	
62.0													4.3		
θ(°)	0~ 84.5	27~ 84.5	43~ 84.5	13~ 84.5	23~ 84.5	42~ 84.5	0~ 84.5	25~ 84.5	42~ 84.5	13~ 84.5	27~ 84.5	42~ 84.5	15~ 84.5	27~ 84.5	45~ 84.5
標準フック	80t						35t								
フック重量	1550kg						950kg								
標準巻掛本数	5						3								

カウンタウエイト 98t、アウトリガ張出幅 8.5m

PS+ブーム+2.0m+11.5m油圧チルトジブ

単位:t

ブーム長さ(m) 作業半径 (m)	40.4			45.4			50.5			55.6			60.0		
	オフセット			オフセット			オフセット			オフセット			オフセット		
	0°	20°	40°	0°	20°	40°	0°	20°	40°	0°	20°	40°	0°	20°	40°
10.0	45.4														
11.0	45.4			36.6											
12.0	44.8			36.6			27.9								
14.0	42.2	32.1		36.6	30.8		25.8			22.3			19.5		
16.0	39.8	30.6	24.5	36.6	29.6		24.0	19.0		20.7	17.0		19.5		
18.0	37.6	29.3	23.9	36.1	28.4	24.2	22.5	18.0	15.5	19.3	16.0		18.4	15.4	
20.0	35.3	28.1	23.3	33.9	27.4	23.5	21.1	17.1	14.9	18.1	15.2	13.5	17.3	14.6	
22.0	32.0	27.1	22.8	30.6	26.4	22.8	19.9	16.4	14.3	17.0	14.4	12.9	16.3	13.9	12.4
24.0	29.2	26.1	22.3	27.9	25.6	22.3	18.8	15.7	13.8	16.1	13.7	12.4	15.4	13.2	11.9
26.0	26.7	25.3	21.9	25.5	24.1	21.8	17.9	15.0	13.4	15.2	13.1	11.9	14.6	12.6	11.4
28.0	24.6	23.5	21.5	23.5	22.3	21.3	17.1	14.4	12.9	14.4	12.6	11.4	13.9	12.1	11.0
30.0	22.7	21.8	21.2	21.7	20.7	20.2	16.3	13.9	12.5	13.7	12.0	11.0	13.1	11.6	10.6
32.0	21.1	20.3	19.9	20.1	19.3	18.9	15.6	13.4	12.2	13.1	11.6	10.6	12.1	11.1	10.3
34.0	19.3	19.0	18.7	18.6	18.0	17.6	15.0	13.0	11.9	12.5	11.1	10.3	11.2	10.5	9.9
36.0	17.4	17.8	17.5	17.4	16.8	16.5	14.4	12.6	11.6	12.0	10.7	10.0	10.4	9.8	9.5
38.0	15.7	16.5	16.5	16.0	15.8	15.6	13.9	12.2	11.3	11.5	10.3	9.7	9.7	9.2	8.9
40.0	14.2	14.9	15.3	14.5	14.8	14.6	13.4	11.9	11.0	11.1	10.0	9.4	9.0	8.6	8.4
42.0	12.9	13.5	13.8	13.2	13.8	13.8	12.9	11.5	10.8	10.7	9.7	9.1	8.4	8.1	7.9
44.0	11.6	12.2		11.9	12.5	12.9	12.3	11.3	10.6	10.3	9.4	8.9	7.9	7.6	7.4
46.0	10.3	10.9		10.7	11.3	11.6	11.1	11.0	10.4	10.0	9.1	8.7	7.4	7.1	7.0
48.0	9.2	9.6		9.5	10.1		10.0	10.6	10.3	9.6	8.9	8.5	6.9	6.7	6.6
50.0	8.2			8.5	9.0		9.0	9.5	9.8	9.3	8.6	8.3	6.5	6.3	6.3
54.0				6.7	7.0		7.2	7.6		7.7	8.2	8.0	5.7	5.6	5.6
58.0							5.6	5.9		6.1	6.5		5.1	5.0	
62.0										4.8	5.0		4.5	4.5	
66.0										2.7			3.5	3.7	
70.0													2.4		
θ(°)	17~ 83	28~ 84.5	44~ 84.5	20~ 83	24~ 84.5	44~ 84.5	22~ 83	26~ 84.5	43~ 84.5	12~ 83	28~ 84.5	43~ 84.5	14~ 83	28~ 84.5	48~ 84.5
標準フック	80t						35t								
フック重量	1550kg						950kg								
標準巻掛本数	4						3								

カウンタウエイト 98t、アウトリガ張出幅 8.5m

PS+ブーム+2.0m+17.5m油圧チルトジブ

単位:t

ブーム長さ(m) 作業半径 (m)	40.4			45.4			50.5			55.6			60.0		
	オフセット			オフセット			オフセット			オフセット			オフセット		
	0°	20°	40°	0°	20°	40°	0°	20°	40°	0°	20°	40°	0°	20°	40°
11.0	32.6														
12.0	32.6			28.2											
14.0	32.6			28.2			21.7								
16.0	31.2	21.3		28.2			21.0			16.9			14.4		
18.0	29.4	20.2		28.1	20.7		19.6	14.9		16.9			14.0		
20.0	27.9	19.2		26.9	19.8		18.3	14.1		15.9	12.7		13.6		
22.0	26.5	18.3	14.0	25.6	18.9		17.2	13.4		14.9	12.1		13.1	11.6	
24.0	25.2	17.5	13.6	24.5	18.0	13.8	16.2	12.8	11.0	14.0	11.5		12.7	11.1	
26.0	24.0	16.7	13.3	23.2	17.3	13.5	15.3	12.3	10.6	13.2	10.9	9.6	12.1	10.6	9.3
28.0	22.4	16.1	12.9	21.3	16.6	13.1	14.5	11.8	10.2	12.5	10.4	9.2	11.6	10.1	8.9
30.0	20.7	15.4	12.7	19.7	16.0	12.9	13.8	11.3	9.9	11.9	10.0	8.9	11.1	9.7	8.6
32.0	19.2	14.9	12.4	18.2	15.5	12.6	13.2	10.9	9.6	11.3	9.6	8.6	10.6	9.3	8.3
34.0	17.8	14.4	12.2	16.9	15.0	12.4	12.6	10.5	9.3	10.8	9.2	8.3	9.8	8.9	8.0
36.0	16.6	13.9	12.0	15.8	14.5	12.2	12.1	10.1	9.1	10.3	8.8	8.0	9.1	8.4	7.6
38.0	15.5	13.5	11.8	14.7	14.0	12.0	11.6	9.8	8.8	9.8	8.5	7.8	8.4	7.8	7.3
40.0	14.5	13.1	11.7	13.7	13.3	11.8	11.1	9.5	8.6	9.4	8.2	7.5	7.8	7.3	7.0
42.0	13.5	12.8	11.6	12.8	12.5	11.7	10.7	9.2	8.4	9.0	7.9	7.3	7.3	6.9	6.7
44.0	12.3	12.5	11.5	12.0	11.8	11.6	10.3	9.0	8.2	8.7	7.7	7.1	6.7	6.4	6.3
46.0	11.1	11.8	11.5	11.2	11.1	11.0	10.0	8.7	8.0	8.4	7.4	6.9	6.3	6.0	5.9
48.0	10.0	10.8	11.1	10.1	10.4	10.4	9.7	8.5	7.9	8.1	7.2	6.7	5.9	5.6	5.6
50.0	8.9	9.7		9.0	9.9	9.8	9.4	8.3	7.8	7.8	7.0	6.6	5.5	5.3	5.3
54.0	7.1	7.6		7.2	7.9		7.6	7.9	7.5	7.3	6.6	6.3	4.8	4.7	4.7
58.0				5.7	6.1		6.1	6.7		6.3	6.3	6.0	4.2	4.1	4.2
62.0				3.2			4.7	5.2		5.0	5.6		3.6	3.6	3.7
66.0							3.6			3.8	4.3		3.2	3.2	
70.0										2.8	3.1		2.7	2.8	
74.0													1.8	2.0	
θ(°)	23~ 83	28~ 84.5	44~ 84.5	11~ 83	30~ 84.5	48~ 84.5	16~ 83	31~ 84.5	47~ 84.5	19~ 83	23~ 84.5	47~ 84.5	20~ 83	24~ 84.5	46~ 84.5
標準フック	35t						35t								
フック重量	950kg						950kg								
標準巻掛本数	3						2								

カウンタウエイト 98t、アウトリガ張出幅 8.5m

PS+ブーム+2.0m+23.5m油圧チルトジブ

単位:t

ブーム長さ(m) 作業半径 (m)	40.4			45.4			50.5			55.6			60.0		
	オフセット			オフセット			オフセット			オフセット			オフセット		
	0°	20°	40°	0°	20°	40°	0°	20°	40°	0°	20°	40°	0°	20°	40°
12.0	24.7														
14.0	24.7			21.4			16.6								
16.0	24.7			21.4			16.6			12.7					
18.0	24.3			21.4			16.6			12.7			10.4		
20.0	23.0	14.4		21.4			16.1			12.7			10.0		
22.0	21.7	13.6		21.1	14.0		15.1	11.3		12.7			9.6		
24.0	20.1	12.9		20.1	13.3		14.1	10.8		12.4	9.8		9.2		
26.0	18.6	12.3	9.3	19.2	12.7		13.3	10.3		11.7	9.4		8.8	9.0	
28.0	17.3	11.7	9.0	18.4	12.1	9.1	12.6	9.9		11.0	8.9		8.3	8.6	
30.0	16.1	11.2	8.7	17.4	11.6	8.9	12.0	9.5	8.1	10.4	8.5	7.4	7.9	8.2	
32.0	15.1	10.7	8.5	16.3	11.2	8.6	11.4	9.1	7.8	9.9	8.1	7.1	7.4	7.7	6.5
34.0	14.2	10.3	8.3	15.3	10.7	8.4	10.8	8.7	7.6	9.4	7.8	6.9	7.0	7.3	6.2
36.0	13.4	9.9	8.1	14.4	10.3	8.2	10.3	8.4	7.3	8.9	7.5	6.6	6.6	6.8	5.9
38.0	12.6	9.6	7.9	13.4	10.0	8.1	9.9	8.1	7.1	8.5	7.2	6.4	6.1	6.5	5.7
40.0	12.0	9.2	7.7	12.5	9.6	7.9	9.5	7.8	6.9	8.1	6.9	6.2	5.8	6.1	5.4
42.0	11.4	8.9	7.6	11.7	9.3	7.7	9.1	7.6	6.7	7.8	6.7	6.0	5.4	5.8	5.1
44.0	10.8	8.6	7.5	11.0	9.0	7.6	8.7	7.3	6.6	7.5	6.4	5.8	5.0	5.5	4.9
46.0	10.3	8.4	7.4	10.3	8.7	7.5	8.4	7.1	6.4	7.2	6.2	5.6	4.7	5.1	4.7
48.0	9.8	8.1	7.3	9.6	8.5	7.4	8.1	6.9	6.3	6.9	6.0	5.5	4.4	4.8	4.5
50.0	9.4	7.9	7.2	9.1	8.3	7.3	7.8	6.7	6.1	6.6	5.8	5.3	4.1	4.4	4.3
54.0	7.7	7.6	7.2	7.7	7.9	7.2	7.3	6.4	5.9	6.1	5.4	5.0	3.5	3.9	3.9
58.0	6.1	6.8		6.1	7.0	7.1	6.3	6.1	5.7	5.7	5.1	4.8	3.0	3.4	3.4
62.0	4.7			4.8	5.4		5.0	5.8	5.5	5.2	4.8	4.5	2.5	2.9	3.0
66.0				3.6	4.0		3.8	4.4		4.0	4.4	4.3	2.1	2.5	2.6
70.0							2.8	3.2		3.0	3.5		1.8	2.1	
74.0										2.1	2.5		1.5	1.8	
θ(°)	16~ 83	33~ 84.5	45~ 84.5	19~ 83	25~ 84.5	45~ 84.5	21~ 83	27~ 84.5	45~ 84.5	23~ 83	29~ 84.5	45~ 84.5	30~ 83	36~ 84.5	50~ 84.5
標準フック	35t						35t								
フック重量	950kg						950kg								
標準巻掛本数	3						2								

PS+油圧チルトジブ

カウンタウエイト 98t、アウトリガ張出幅 8.5m

PS+ブーム+2.0m+29.5m油圧チルトジブ

単位:t

ブーム長さ(m) 作業半径 (m)	40.4			45.4			50.5			55.6			60.0		
	オフセット			オフセット			オフセット			オフセット			オフセット		
	0°	20°	40°	0°	20°	40°	0°	20°	40°	0°	20°	40°	0°	20°	40°
14.0	18.7			16.1											
16.0	18.7			16.1			12.4								
18.0	18.7			16.1			12.4						7.0		
20.0	18.7			16.1			12.4			8.7			6.7		
22.0	17.8			16.1			12.4			8.7			6.3		
24.0	16.5	10.2		16.1	10.5		12.4			8.7			6.0		
26.0	15.2	9.6		15.7	9.9		11.8	8.9		8.6			5.6		
28.0	14.1	9.1		15.1	9.4		11.1	8.5		8.4	8.0		5.3		
30.0	13.1	8.7		14.1	9.0		10.5	8.1		8.3	7.6		4.9	6.7	
32.0	12.2	8.3	6.2	13.1	8.6	6.3	10.0	7.8		8.1	7.3		4.6	6.3	
34.0	11.4	7.9	6.0	12.3	8.2	6.1	9.5	7.5	6.2	7.9	6.9		4.2	5.9	
36.0	10.7	7.6	5.9	11.5	7.9	6.0	9.0	7.2	6.0	7.7	6.6	5.8	3.9	5.5	
38.0	10.0	7.2	5.7	10.9	7.5	5.8	8.6	6.9	5.9	7.5	6.4	5.6	3.5	5.2	4.4
40.0	9.5	6.9	5.5	10.2	7.2	5.6	8.2	6.6	5.7	7.3	6.1	5.4	3.2	4.9	4.2
42.0	8.9	6.7	5.4	9.7	7.0	5.5	7.8	6.4	5.6	7.0	5.8	5.2	2.9	4.6	4.0
44.0	8.5	6.4	5.3	9.2	6.7	5.4	7.5	6.2	5.4	6.7	5.6	5.0	2.6	4.3	3.8
46.0	8.0	6.2	5.1	8.7	6.5	5.2	7.2	6.0	5.2	6.4	5.4	4.8	2.3	4.1	3.6
48.0	7.6	6.0	5.0	8.3	6.3	5.1	6.9	5.8	5.1	6.1	5.2	4.6	2.1	3.9	3.4
50.0	7.2	5.8	5.0	7.9	6.1	5.0	6.7	5.6	5.0	5.9	5.0	4.4	1.8	3.6	3.3
54.0	6.6	5.4	4.8	7.1	5.7	4.9	6.2	5.2	4.7	5.3	4.5	4.0		3.2	3.0
58.0	6.0	5.1	4.8	6.3	5.4	4.8	5.8	4.9	4.4	4.8	4.1	3.7		2.7	2.7
62.0	5.1	4.9		5.0	5.1	4.7	5.1	4.6	4.2	4.3	3.8	3.4		2.3	2.4
66.0	3.9	4.5		3.8	4.6		3.9	4.3	4.0	3.9	3.4	3.2		1.9	2.0
70.0				2.8	3.3		2.9	3.7		3.2	3.2	3.0		1.6	1.7
74.0							2.0	2.5		2.3	2.9				
78.0											2.0				
θ(°)	21~ 83	29~ 84.5	49~ 84.5	23~ 83	31~ 84.5	49~ 84.5	25~ 83	32~ 84.5	49~ 84.5	33~ 83	34~ 84.5	49~ 84.5	59~ 83	49~ 84.5	53~ 84.5
標準フック	35t									12.2t					
フック重量	950kg									440kg					
標準巻掛本数	2									1					

カウンタウエイト 98t、アウトリガ張出幅 8.5m

PS+ブーム+2.0m+35.5m油圧チルトジブ

単位:t

ブーム長さ(m) 作業半径 (m)	40.4			45.4			50.5			55.6			60.0		
	オフセット			オフセット			オフセット			オフセット			オフセット		
	0°	20°	40°	0°	20°	40°	0°	20°	40°	0°	20°	40°	0°	20°	40°
14.0	14.1														
16.0	14.1			12.2											
18.0	14.1			12.2			8.8								
20.0	14.1			12.2			8.8			6.1			4.4		
22.0	14.1			12.2			8.8			6.1			4.2		
24.0	13.9			12.2			8.8			6.1			3.8		
26.0	13.0	7.9		12.2			8.8			6.0			3.5		
28.0	12.0	7.5		12.2	7.7		8.8			5.8			3.2		
30.0	11.1	7.1		11.8	7.3		8.8	7.4		5.7			2.9		
32.0	10.3	6.7		11.1	6.9		8.8	7.1		5.5	6.5		2.6	5.4	
34.0	9.6	6.4		10.3	6.6		8.8	6.8		5.3	6.2		2.2	5.0	
36.0	8.9	6.1	4.5	9.7	6.3		8.3	6.5		5.2	5.9		1.9	4.7	
38.0	8.4	5.8	4.3	9.0	6.0	4.4	7.9	6.2		5.0	5.6		1.6	4.4	
40.0	7.9	5.5	4.2	8.5	5.7	4.2	7.5	6.0	4.5	4.8	5.4			4.1	
42.0	7.4	5.3	4.0	8.0	5.5	4.1	7.2	5.7	4.4	4.6	5.1	4.4		3.9	3.3
44.0	7.0	5.0	3.9	7.5	5.3	4.0	6.9	5.5	4.3	4.3	4.9	4.2		3.6	3.1
46.0	6.6	4.8	3.8	7.1	5.0	3.9	6.6	5.3	4.1	4.1	4.6	4.0		3.4	2.9
48.0	6.2	4.6	3.7	6.7	4.8	3.7	6.3	5.1	4.0	3.9	4.3	3.8		3.2	2.7
50.0	5.9	4.4	3.6	6.4	4.7	3.7	6.0	4.9	3.9	3.7	4.1	3.6		3.0	2.6
54.0	5.3	4.1	3.4	5.8	4.3	3.5	5.6	4.5	3.7	3.2	3.7	3.2		2.6	2.3
58.0	4.8	3.8	3.3	5.2	4.0	3.3	5.0	4.1	3.6	2.7	3.3	2.9		2.3	2.0
62.0	4.3	3.6	3.2	4.7	3.8	3.2	4.6	3.8	3.4	2.3	3.0	2.6		1.9	1.8
66.0	4.0	3.4	3.2	4.2	3.6	3.2	4.2	3.5	3.2	1.8	2.7	2.4			1.6
70.0	3.3	3.3		3.1	3.4	3.2	3.3	3.3	3.0		2.4	2.2			
74.0	2.2			2.2	2.9		2.4	3.1	2.9		2.2	2.0			
78.0					1.8		1.6	2.3			2.0	1.8			
82.0											1.5				
θ(°)	14~ 83	34~ 84.5	46~ 84.5	26~ 83	26~ 84.5	47~ 84.5	28~ 83	37~ 84.5	47~ 84.5	47~ 83	38~ 84.5	48~ 84.5	70~ 83	61~ 84.5	63~ 84.5
標準フック	35t									12.2t					
フック重量	950kg									440kg					
標準巻掛本数	2									1					

カウンタウエイト 98t、アウトリガ張出幅 8.5m

PS+ブーム+2.0m+41.5m油圧チルトジブ

単位:t

ブーム長さ(m) 作業半径 (m)	40.4			45.4			50.5			55.6			60.0		
	オフセット			オフセット			オフセット			オフセット			オフセット		
	0°	20°	40°	0°	20°	40°	0°	20°	40°	0°	20°	40°	0°	20°	40°
16.0	10.1			8.6											
18.0	10.1			8.6			6.0								
20.0	10.1			8.6			6.0					3.5			
22.0	10.1			8.6			6.0				3.5			1.9	
24.0	10.1			8.6			6.0				3.5			1.6	
26.0	10.1			8.6			6.0				3.4				
28.0	10.1			8.6			6.0				3.2				
30.0	9.5	5.8		8.6			6.0				3.1				
32.0	8.8	5.4		8.6	5.6		6.0				2.9				
34.0	8.2	5.1		8.6	5.3		6.0	5.4			2.8				
36.0	7.6	4.8		8.2	5.0		6.0	5.1			2.6	4.8			3.1
38.0	7.0	4.5		7.6	4.7		6.0	4.9			2.4	4.6			3.1
40.0	6.5	4.2		7.1	4.4		6.0	4.6			2.2	4.3			3.1
42.0	6.1	4.0	2.8	6.6	4.2		6.0	4.4			2.0	4.0			2.9
44.0	5.7	3.8	2.6	6.2	4.0	2.7	5.9	4.1			1.8	3.7			2.7
46.0	5.3	3.6	2.5	5.8	3.8	2.6	5.6	3.9	2.6		1.6	3.5			2.5
48.0	4.9	3.4	2.4	5.4	3.6	2.5	5.3	3.7	2.5		3.2	2.6			2.3
50.0	4.6	3.2	2.3	5.1	3.4	2.4	5.0	3.6	2.4		3.0	2.5			2.1
54.0	4.1	2.9	2.1	4.5	3.1	2.2	4.4	3.2	2.3		2.6	2.2			1.7
58.0	3.6	2.6	2.0	4.0	2.8	2.0	3.9	2.9	2.1		2.3	1.9			
62.0	3.2	2.3	1.8	3.5	2.5	1.9	3.5	2.7	2.0		1.9	1.6			
66.0	2.8	2.1	1.7	3.1	2.3	1.8	3.1	2.4	1.8		1.6				
70.0	2.5	1.9	1.7	2.8	2.1	1.7	2.7	2.1	1.8						
74.0	2.2	1.8		2.2	1.9	1.7	2.2	1.9	1.6						
78.0	1.6	1.7			1.8			1.7	1.5						
θ(°)	20~ 83	30~ 84.5	51~ 84.5	35~ 83	39~ 84.5	51~ 84.5	40~ 83	45~ 84.5	51~ 84.5	65~ 83	60~ 84.5	70~ 84.5	80~ 83	70~ 84.5	80~ 84.5
標準フック	12.2t														
フック重量	440kg														
標準巻掛本数	1														

カウンタウエイト 98t、アウトリガ張出幅 8.5m

PS+ブーム+2.0m+47.5m油圧チルトジブ

単位:t

ブーム長さ(m) 作業半径 (m)	40.4		45.4		50.5	
	オフセット		オフセット		オフセット	
	0°	20°	0°	20°	0°	20°
16.0	6.7					
18.0	6.7		5.6			
20.0	6.7		5.6		3.3	
22.0	6.7		5.6		3.3	
24.0	6.7		5.6		3.3	
26.0	6.7		5.6		3.3	
28.0	6.7		5.6		3.3	
30.0	6.7		5.6		3.3	
32.0	6.7		5.6		3.3	
34.0	6.4	3.7	5.6		3.3	
36.0	5.9	3.5	5.6	3.6	3.3	
38.0	5.4	3.2	5.6	3.4	3.3	3.5
40.0	5.0	3.0	5.4	3.1	3.3	3.3
42.0	4.6	2.8	5.0	2.9	3.3	3.1
44.0	4.3	2.6	4.7	2.7	3.3	2.9
46.0	4.0	2.4	4.3	2.6	3.3	2.7
48.0	3.7	2.3	4.0	2.4	3.3	2.5
50.0	3.4	2.1	3.7	2.2	3.3	2.4
54.0	2.9	1.8	3.2	1.9	3.3	2.1
58.0	2.5	1.6	2.8	1.7	2.9	1.8
62.0	2.1		2.4	1.5	2.5	1.6
66.0	1.8		2.1		2.2	
70.0	1.5		1.8		1.8	
74.0			1.5		1.5	
θ(°)	40~ 84.5	62~ 84.5	40~ 84.5	62~ 84.5	44~ 84.5	65~ 84.5
標準フック	12.2t					
フック重量	440kg					
標準巻掛本数	1					

PS+油圧チルトジブ

カウンタウエイト 98t、アウトリガ張出幅 8.0m

PS+ブーム+2.0m+3.5m油圧チルトジブ

単位:t

ブーム長さ(m) 作業半径 (m)	40.4			45.4			50.5			55.6			60.0		
	オフセット			オフセット			オフセット			オフセット			オフセット		
	0°	20°	40°	0°	20°	40°	0°	20°	40°	0°	20°	40°	0°	20°	40°
8.0	58.6														
9.0	58.6	58.6		52.9											
10.0	58.6	58.6	53.9	52.0	48.4		34.9								
11.0	58.6	57.7	52.9	50.7	47.2	45.0	33.7	30.3		28.3					
12.0	58.6	56.5	51.9	49.5	46.2	44.1	32.6	29.4	27.4	27.3	25.1		26.0		
14.0	56.8	54.2	50.2	47.3	44.4	42.5	30.6	27.8	26.1	25.5	23.6	22.4	24.3	22.5	21.4
16.0	50.2	48.4	47.2	45.4	42.8	41.1	28.9	26.4	24.9	23.9	22.2	21.2	22.8	21.3	20.3
18.0	44.8	43.4	42.5	42.5	41.1	39.9	27.4	25.2	23.9	22.5	21.1	20.1	21.5	20.2	19.3
20.0	40.3	39.2	38.6	38.3	37.2	36.5	26.1	24.1	22.9	21.3	20.0	19.2	20.4	19.2	18.4
22.0	36.5	35.7	35.2	34.7	33.8	33.3	24.9	23.1	22.1	20.2	19.1	18.4	19.4	18.3	17.6
24.0	32.6	32.7	32.3	31.6	30.9	30.6	23.8	22.3	21.4	19.3	18.2	17.6	18.5	17.5	16.9
26.0	28.5	28.9	29.1	28.9	28.4	28.2	22.9	21.5	20.7	18.4	17.5	16.9	17.6	16.8	16.2
28.0	25.0	25.4	25.6	25.5	25.9	26.0	22.1	20.8	20.1	17.6	16.8	16.3	16.8	16.1	15.6
30.0	22.1	22.4	22.6	22.6	22.9	23.1	21.3	20.1	19.5	16.9	16.1	15.7	15.6	15.2	14.9
32.0	19.7	19.9	20.0	20.1	20.4	20.5	20.6	19.5	19.0	16.2	15.6	15.2	14.5	14.1	13.9
34.0	17.5	17.7	17.8	18.0	18.2	18.3	18.7	18.9	18.6	15.7	15.0	14.7	13.5	13.2	13.0
36.0	15.6	15.8		16.1	16.3	16.4	16.8	17.0	17.1	15.1	14.6	14.3	12.6	12.3	12.2
38.0	14.0	14.1		14.4	14.6	14.6	15.1	15.3	15.4	14.6	14.1	13.9	11.8	11.6	11.5
40.0	12.3	12.4		12.9	13.1		13.6	13.8	13.8	14.2	13.7	13.5	11.0	10.9	10.8
42.0	10.9			11.4	11.6		12.3	12.4	12.5	12.9	13.0	13.1	10.4	10.2	10.2
44.0	3.8			10.1	10.2		10.9	11.1		11.7	11.8	11.9	9.7	9.6	9.6
46.0				8.9	8.9		9.7	9.8		10.4	10.6	10.6	9.2	9.1	9.1
48.0				7.4			8.6	8.7		9.3	9.5		8.7	8.6	8.6
50.0							7.6	7.7		8.3	8.4		8.2	8.1	
54.0							2.5			6.5	6.6		6.6	6.7	
58.0										4.9			5.1	5.1	
62.0													3.8		
θ(°)	0~ 84.5	27~ 84.5	43~ 84.5	13~ 84.5	23~ 84.5	42~ 84.5	0~ 84.5	25~ 84.5	42~ 84.5	13~ 84.5	27~ 84.5	42~ 84.5	15~ 84.5	27~ 84.5	45~ 84.5
標準フック	80t						35t								
フック重量	1550kg						950kg								
標準巻掛本数	5						3								

カウンタウエイト 98t、アウトリガ張出幅 8.0m

PS+ブーム+2.0m+11.5m油圧チルトジブ

単位:t

ブーム長さ(m) 作業半径 (m)	40.4			45.4			50.5			55.6			60.0		
	オフセット			オフセット			オフセット			オフセット			オフセット		
	0°	20°	40°	0°	20°	40°	0°	20°	40°	0°	20°	40°	0°	20°	40°
10.0	45.4														
11.0	45.4			36.6											
12.0	44.8			36.6			27.9								
14.0	42.2	32.1		36.6	30.8		25.8			22.3			19.5		
16.0	39.8	30.6	24.5	36.6	29.6		24.0	19.0		20.7	17.0		19.5		
18.0	37.6	29.3	23.9	36.1	28.4	24.2	22.5	18.0	15.5	19.3	16.0		18.4	15.4	
20.0	35.3	28.1	23.3	33.9	27.4	23.5	21.1	17.1	14.9	18.1	15.2	13.5	17.3	14.6	
22.0	32.0	27.1	22.8	30.6	26.4	22.8	19.9	16.4	14.3	17.0	14.4	12.9	16.3	13.9	12.4
24.0	29.2	26.1	22.3	27.9	25.6	22.3	18.8	15.7	13.8	16.1	13.7	12.4	15.4	13.2	11.9
26.0	26.7	25.3	21.9	25.5	24.1	21.8	17.9	15.0	13.4	15.2	13.1	11.9	14.6	12.6	11.4
28.0	24.6	23.5	21.5	23.5	22.3	21.3	17.1	14.4	12.9	14.4	12.6	11.4	13.9	12.1	11.0
30.0	22.7	21.8	21.2	21.7	20.7	20.2	16.3	13.9	12.5	13.7	12.0	11.0	13.1	11.6	10.6
32.0	20.7	20.3	19.9	20.1	19.3	18.9	15.6	13.4	12.2	13.1	11.6	10.6	12.1	11.1	10.3
34.0	18.5	19.0	18.7	18.6	18.0	17.6	15.0	13.0	11.9	12.5	11.1	10.3	11.2	10.5	9.9
36.0	16.7	17.5	17.5	17.0	16.8	16.5	14.4	12.6	11.6	12.0	10.7	10.0	10.4	9.8	9.5
38.0	15.0	15.8	16.3	15.3	15.8	15.6	13.9	12.2	11.3	11.5	10.3	9.7	9.7	9.2	8.9
40.0	13.5	14.2	14.6	13.8	14.6	14.6	13.4	11.9	11.0	11.1	10.0	9.4	9.0	8.6	8.4
42.0	12.2	12.8	13.1	12.5	13.2	13.6	12.9	11.5	10.8	10.7	9.7	9.1	8.4	8.1	7.9
44.0	10.9	11.5		11.2	11.9	12.2	11.7	11.3	10.6	10.3	9.4	8.9	7.9	7.6	7.4
46.0	9.7	10.2		10.0	10.6	11.0	10.5	11.0	10.4	10.0	9.1	8.7	7.4	7.1	7.0
48.0	8.6	9.0		8.9	9.4		9.4	10.0	10.3	9.6	8.9	8.5	6.9	6.7	6.6
50.0	7.6			7.9	8.3		8.3	8.9	9.2	8.9	8.6	8.3	6.5	6.3	6.3
54.0				6.1	6.4		6.6	7.0		7.1	7.6	7.8	5.7	5.6	5.6
58.0							5.1	5.3		5.5	5.9		5.1	5.0	
62.0										4.2	4.5		4.1	4.5	
66.0										2.7			3.0	3.2	
70.0													2.0		
θ(°)	17~ 83	28~ 84.5	44~ 84.5	20~ 83	24~ 84.5	44~ 84.5	22~ 83	26~ 84.5	43~ 84.5	12~ 83	28~ 84.5	43~ 84.5	14~ 83	28~ 84.5	48~ 84.5
標準フック	80t						35t								
フック重量	1550kg						950kg								
標準巻掛本数	4						3								

カウンタウエイト 98t、アウトリガ張出幅 8.0m

PS+ブーム+2.0m+17.5m油圧チルトジブ

単位:t

ブーム長さ(m) 作業半径 (m)	40.4			45.4			50.5			55.6			60.0		
	オフセット			オフセット			オフセット			オフセット			オフセット		
	0°	20°	40°	0°	20°	40°	0°	20°	40°	0°	20°	40°	0°	20°	40°
11.0	32.6														
12.0	32.6			28.2											
14.0	32.6			28.2			21.7								
16.0	31.2	21.3		28.2			21.0			16.9			14.4		
18.0	29.4	20.2		28.1	20.7		19.6	14.9		16.9			14.0		
20.0	27.9	19.2		26.9	19.8		18.3	14.1		15.9	12.7		13.6		
22.0	26.5	18.3	14.0	25.6	18.9		17.2	13.4		14.9	12.1		13.1	11.6	
24.0	25.2	17.5	13.6	24.5	18.0	13.8	16.2	12.8	11.0	14.0	11.5		12.7	11.1	
26.0	24.0	16.7	13.3	23.2	17.3	13.5	15.3	12.3	10.6	13.2	10.9	9.6	12.1	10.6	9.3
28.0	22.4	16.1	12.9	21.3	16.6	13.1	14.5	11.8	10.2	12.5	10.4	9.2	11.6	10.1	8.9
30.0	20.7	15.4	12.7	19.7	16.0	12.9	13.8	11.3	9.9	11.9	10.0	8.9	11.1	9.7	8.6
32.0	19.2	14.9	12.4	18.2	15.5	12.6	13.2	10.9	9.6	11.3	9.6	8.6	10.6	9.3	8.3
34.0	17.8	14.4	12.2	16.9	15.0	12.4	12.6	10.5	9.3	10.8	9.2	8.3	9.8	8.9	8.0
36.0	16.6	13.9	12.0	15.8	14.5	12.2	12.1	10.1	9.1	10.3	8.8	8.0	9.1	8.4	7.6
38.0	15.5	13.5	11.8	14.7	14.0	12.0	11.6	9.8	8.8	9.8	8.5	7.8	8.4	7.8	7.3
40.0	14.2	13.1	11.7	13.7	13.3	11.8	11.1	9.5	8.6	9.4	8.2	7.5	7.8	7.3	7.0
42.0	12.9	12.8	11.6	12.8	12.5	11.7	10.7	9.2	8.4	9.0	7.9	7.3	7.3	6.9	6.7
44.0	11.6	12.5	11.5	11.7	11.8	11.6	10.3	9.0	8.2	8.7	7.7	7.1	6.7	6.4	6.3
46.0	10.4	11.4	11.5	10.5	11.1	11.0	10.0	8.7	8.0	8.4	7.4	6.9	6.3	6.0	5.9
48.0	9.3	10.2	10.7	9.4	10.4	10.4	9.7	8.5	7.9	8.1	7.2	6.7	5.9	5.6	5.6
50.0	8.3	9.1		8.4	9.3	9.8	8.8	8.3	7.8	7.8	7.0	6.6	5.5	5.3	5.3
54.0	6.5	7.0		6.6	7.3		7.0	7.8	7.5	7.3	6.6	6.3	4.8	4.7	4.7
58.0				5.1	5.6		5.5	6.1		5.8	6.3	6.0	4.2	4.1	4.2
62.0				3.2			4.2	4.6		4.5	5.0		3.6	3.6	3.7
66.0							3.1			3.3	3.8		3.2	3.2	
70.0										2.4	2.6		2.2	2.6	
74.0													1.5		
θ(°)	23~ 83	28~ 84.5	44~ 84.5	11~ 83	30~ 84.5	48~ 84.5	16~ 83	31~ 84.5	47~ 84.5	19~ 83	23~ 84.5	47~ 84.5	28~ 83	24~ 84.5	46~ 84.5
標準フック フック重量	35t 950kg						35t 950kg								
標準巻掛本数	3						2								

カウンタウエイト 98t、アウトリガ張出幅 8.0m

PS+ブーム+2.0m+23.5m油圧チルトジブ

単位:t

ブーム長さ(m) 作業半径 (m)	40.4			45.4			50.5			55.6			60.0		
	オフセット			オフセット			オフセット			オフセット			オフセット		
	0°	20°	40°	0°	20°	40°	0°	20°	40°	0°	20°	40°	0°	20°	40°
12.0	24.7														
14.0	24.7			21.4			16.6								
16.0	24.7			21.4			16.6			12.7					
18.0	24.3			21.4			16.6			12.7			10.4		
20.0	23.0	14.4		21.4			16.1			12.7			10.0		
22.0	21.7	13.6		21.1	14.0		15.1	11.3		12.7			9.6		
24.0	20.1	12.9		20.1	13.3		14.1	10.8		12.4	9.8		9.2		
26.0	18.6	12.3	9.3	19.2	12.7		13.3	10.3		11.7	9.4		8.8	9.0	
28.0	17.3	11.7	9.0	18.4	12.1	9.1	12.6	9.9		11.0	8.9		8.3	8.6	
30.0	16.1	11.2	8.7	17.4	11.6	8.9	12.0	9.5	8.1	10.4	8.5	7.4	7.9	8.2	
32.0	15.1	10.7	8.5	16.3	11.2	8.6	11.4	9.1	7.8	9.9	8.1	7.1	7.4	7.7	6.5
34.0	14.2	10.3	8.3	15.3	10.7	8.4	10.8	8.7	7.6	9.4	7.8	6.9	7.0	7.3	6.2
36.0	13.4	9.9	8.1	14.4	10.3	8.2	10.3	8.4	7.3	8.9	7.5	6.6	6.6	6.8	5.9
38.0	12.6	9.6	7.9	13.4	10.0	8.1	9.9	8.1	7.1	8.5	7.2	6.4	6.1	6.5	5.7
40.0	12.0	9.2	7.7	12.5	9.6	7.9	9.5	7.8	6.9	8.1	6.9	6.2	5.8	6.1	5.4
42.0	11.4	8.9	7.6	11.7	9.3	7.7	9.1	7.6	6.7	7.8	6.7	6.0	5.4	5.8	5.1
44.0	10.8	8.6	7.5	11.0	9.0	7.6	8.7	7.3	6.6	7.5	6.4	5.8	5.0	5.5	4.9
46.0	10.3	8.4	7.4	10.3	8.7	7.5	8.4	7.1	6.4	7.2	6.2	5.6	4.7	5.1	4.7
48.0	9.8	8.1	7.3	9.6	8.5	7.4	8.1	6.9	6.3	6.9	6.0	5.5	4.4	4.8	4.5
50.0	8.9	7.9	7.2	8.9	8.3	7.3	7.8	6.7	6.1	6.6	5.8	5.3	4.1	4.4	4.3
54.0	7.1	7.6	7.2	7.1	7.9	7.2	7.3	6.4	5.9	6.1	5.4	5.0	3.5	3.9	3.9
58.0	5.6	6.2		5.6	6.4	6.9	5.8	6.1	5.7	5.7	5.1	4.8	3.0	3.4	3.4
62.0	4.3			4.3	4.9		4.5	5.3	5.5	4.7	4.8	4.5	2.5	2.9	3.0
66.0				3.1	3.5		3.3	3.9		3.5	4.2	4.3	2.1	2.5	2.6
70.0							2.3	2.7		2.5	3.1		1.8	2.1	
74.0										1.6	2.0			1.8	
θ(°)	16~ 83	33~ 84.5	45~ 84.5	19~ 83	25~ 84.5	45~ 84.5	21~ 83	27~ 84.5	45~ 84.5	23~ 83	29~ 84.5	45~ 84.5	36~ 83	36~ 84.5	50~ 84.5
標準フック フック重量	35t 950kg						35t 950kg								
標準巻掛本数	3						2								

PS+油圧チルトジブ

カウンタウエイト 98t、アウトリガ張出幅 8.0m

PS+ブーム+2.0m+29.5m油圧チルトジブ

単位:t

ブーム長さ(m) 作業半径 (m)	40.4			45.4			50.5			55.6			60.0		
	オフセット			オフセット			オフセット			オフセット			オフセット		
	0°	20°	40°	0°	20°	40°	0°	20°	40°	0°	20°	40°	0°	20°	40°
14.0	18.7			16.1											
16.0	18.7			16.1			12.4								
18.0	18.7			16.1			12.4						7.0		
20.0	18.7			16.1			12.4			8.7			6.7		
22.0	17.8			16.1			12.4			8.7			6.3		
24.0	16.5	10.2		16.1	10.5		12.4			8.7			6.0		
26.0	15.2	9.6		15.7	9.9		11.8	8.9		8.6			5.6		
28.0	14.1	9.1		15.1	9.4		11.1	8.5		8.4	8.0		5.3		
30.0	13.1	8.7		14.1	9.0		10.5	8.1		8.3	7.6		4.9	6.7	
32.0	12.2	8.3	6.2	13.1	8.6	6.3	10.0	7.8		8.1	7.3		4.6	6.3	
34.0	11.4	7.9	6.0	12.3	8.2	6.1	9.5	7.5	6.2	7.9	6.9		4.2	5.9	
36.0	10.7	7.6	5.9	11.5	7.9	6.0	9.0	7.2	6.0	7.7	6.6	5.8	3.9	5.5	
38.0	10.0	7.2	5.7	10.9	7.5	5.8	8.6	6.9	5.9	7.5	6.4	5.6	3.5	5.2	4.4
40.0	9.5	6.9	5.5	10.2	7.2	5.6	8.2	6.6	5.7	7.3	6.1	5.4	3.2	4.9	4.2
42.0	8.9	6.7	5.4	9.7	7.0	5.5	7.8	6.4	5.6	7.0	5.8	5.2	2.9	4.6	4.0
44.0	8.5	6.4	5.3	9.2	6.7	5.4	7.5	6.2	5.4	6.7	5.6	5.0	2.6	4.3	3.8
46.0	8.0	6.2	5.1	8.7	6.5	5.2	7.2	6.0	5.2	6.4	5.4	4.8	2.3	4.1	3.6
48.0	7.6	6.0	5.0	8.3	6.3	5.1	6.9	5.8	5.1	6.1	5.2	4.6	2.1	3.9	3.4
50.0	7.2	5.8	5.0	7.9	6.1	5.0	6.7	5.6	5.0	5.9	5.0	4.4	1.8	3.6	3.3
54.0	6.6	5.4	4.8	7.1	5.7	4.9	6.2	5.2	4.7	5.3	4.5	4.0		3.2	3.0
58.0	5.9	5.1	4.8	5.8	5.4	4.8	5.8	4.9	4.4	4.8	4.1	3.7		2.7	2.7
62.0	4.6	4.9		4.5	5.1	4.7	4.6	4.6	4.2	4.3	3.8	3.4		2.3	2.4
66.0	3.4	4.0		3.3	4.1		3.5	4.3	4.0	3.8	3.4	3.2		1.9	2.0
70.0				2.3	2.9		2.5	3.2		2.7	3.2	3.0		1.6	1.7
74.0							1.6	2.1		1.8	2.5				
78.0										1.5					
θ(°)	21~ 83	29~ 84.5	49~ 84.5	23~ 83	31~ 84.5	49~ 84.5	25~ 83	32~ 84.5	49~ 84.5	33~ 83	34~ 84.5	49~ 84.5	59~ 83	49~ 84.5	53~ 84.5
標準フック	35t						12.2t								
フック重量	950kg						440kg								
標準巻掛本数	2						1								

カウンタウエイト 98t、アウトリガ張出幅 8.0m

PS+ブーム+2.0m+35.5m油圧チルトジブ

単位:t

ブーム長さ(m) 作業半径 (m)	40.4			45.4			50.5			55.6			60.0		
	オフセット			オフセット			オフセット			オフセット			オフセット		
	0°	20°	40°	0°	20°	40°	0°	20°	40°	0°	20°	40°	0°	20°	40°
14.0	14.1														
16.0	14.1			12.2											
18.0	14.1			12.2			8.8								
20.0	14.1			12.2			8.8			6.1			4.4		
22.0	14.1			12.2			8.8			6.1			4.2		
24.0	13.9			12.2			8.8			6.1			3.8		
26.0	13.0	7.9		12.2			8.8			6.0			3.5		
28.0	12.0	7.5		12.2	7.7		8.8			5.8			3.2		
30.0	11.1	7.1		11.8	7.3		8.8	7.4		5.7			2.9		
32.0	10.3	6.7		11.1	6.9		8.8	7.1		5.5	6.5		2.6	5.4	
34.0	9.6	6.4		10.3	6.6		8.8	6.8		5.3	6.2		2.2	5.0	
36.0	8.9	6.1	4.5	9.7	6.3		8.3	6.5		5.2	5.9		1.9	4.7	
38.0	8.4	5.8	4.3	9.0	6.0	4.4	7.9	6.2		5.0	5.6		1.6	4.4	
40.0	7.9	5.5	4.2	8.5	5.7	4.2	7.5	6.0	4.5	4.8	5.4			4.1	
42.0	7.4	5.3	4.0	8.0	5.5	4.1	7.2	5.7	4.4	4.6	5.1	4.4		3.9	3.3
44.0	7.0	5.0	3.9	7.5	5.3	4.0	6.9	5.5	4.3	4.3	4.9	4.2		3.6	3.1
46.0	6.6	4.8	3.8	7.1	5.0	3.9	6.6	5.3	4.1	4.1	4.6	4.0		3.4	2.9
48.0	6.2	4.6	3.7	6.7	4.8	3.7	6.3	5.1	4.0	3.9	4.3	3.8		3.2	2.7
50.0	5.9	4.4	3.6	6.4	4.7	3.7	6.0	4.9	3.9	3.7	4.1	3.6		3.0	2.6
54.0	5.3	4.1	3.4	5.8	4.3	3.5	5.6	4.5	3.7	3.2	3.7	3.2		2.6	2.3
58.0	4.8	3.8	3.3	5.2	4.0	3.3	5.0	4.1	3.6	2.7	3.3	2.9		2.3	2.0
62.0	4.3	3.6	3.2	4.7	3.8	3.2	4.6	3.8	3.4	2.3	3.0	2.6		1.9	1.8
66.0	3.8	3.4	3.2	3.7	3.6	3.2	3.9	3.5	3.2	1.8	2.7	2.4			1.6
70.0	2.8	3.3		2.7	3.4	3.2	2.9	3.3	3.0		2.4	2.2			
74.0	2.0			1.8	2.5		2.0	2.9	2.9		2.2	2.0			
78.0								1.8			2.0	1.8			
θ(°)	14~ 83	34~ 84.5	46~ 84.5	26~ 83	35~ 84.5	47~ 84.5	34~ 83	37~ 84.5	47~ 84.5	47~ 83	43~ 84.5	48~ 84.5	70~ 83	61~ 84.5	63~ 84.5
標準フック	35t						12.2t								
フック重量	950kg						440kg								
標準巻掛本数	2						1								

カウンタウエイト 98t、アウトリガ張出幅 8.0m

PS+ブーム+2.0m+41.5m油圧チルトジブ

単位:t

ブーム長さ(m) 作業半径 (m)	40.4			45.4			50.5			55.6			60.0		
	オフセット			オフセット			オフセット			オフセット			オフセット		
	0°	20°	40°	0°	20°	40°	0°	20°	40°	0°	20°	40°	0°	20°	40°
16.0	10.1			8.6											
18.0	10.1			8.6			6.0								
20.0	10.1			8.6			6.0					3.5			
22.0	10.1			8.6			6.0					3.5		1.9	
24.0	10.1			8.6			6.0					3.5		1.6	
26.0	10.1			8.6			6.0					3.4			
28.0	10.1			8.6			6.0					3.2			
30.0	9.5	5.8		8.6			6.0					3.1			
32.0	8.8	5.4		8.6	5.6		6.0					2.9			
34.0	8.2	5.1		8.6	5.3		6.0	5.4				2.8			
36.0	7.6	4.8		8.2	5.0		6.0	5.1				2.6	4.8		3.1
38.0	7.0	4.5		7.6	4.7		6.0	4.9				2.4	4.6		3.1
40.0	6.5	4.2		7.1	4.4		6.0	4.6				2.2	4.3		3.1
42.0	6.1	4.0	2.8	6.6	4.2		6.0	4.4				2.0	4.0		2.9
44.0	5.7	3.8	2.6	6.2	4.0	2.7	5.9	4.1				1.8	3.7		2.7
46.0	5.3	3.6	2.5	5.8	3.8	2.6	5.6	3.9	2.6			1.6	3.5		2.5
48.0	4.9	3.4	2.4	5.4	3.6	2.5	5.3	3.7	2.5			3.2	2.6		2.3
50.0	4.6	3.2	2.3	5.1	3.4	2.4	5.0	3.6	2.4			3.0	2.5		2.1
54.0	4.1	2.9	2.1	4.5	3.1	2.2	4.4	3.2	2.3			2.6	2.2		1.7
58.0	3.6	2.6	2.0	4.0	2.8	2.0	3.9	2.9	2.1			2.3	1.9		
62.0	3.2	2.3	1.8	3.5	2.5	1.9	3.5	2.7	2.0			1.9	1.6		
66.0	2.8	2.1	1.7	3.1	2.3	1.8	3.1	2.4	1.8			1.6			
70.0	2.5	1.9	1.7	2.7	2.1	1.7	2.7	2.1	1.8						
74.0	2.0	1.8		1.8	1.9	1.7	1.8	1.9	1.6						
78.0		1.7			1.8			1.7	1.5						
θ(°)	28~ 83	30~ 84.5	51~ 84.5	35~ 83	39~ 84.5	51~ 84.5	40~ 83	45~ 84.5	51~ 84.5	65~ 83	60~ 84.5	70~ 84.5	80~ 83	70~ 84.5	80~ 84.5
標準フック	12.2t														
フック重量	440kg														
標準巻掛本数	1														

カウンタウエイト 98t、アウトリガ張出幅 8.0m

PS+ブーム+2.0m+47.5m油圧チルトジブ

単位:t

ブーム長さ(m) 作業半径 (m)	40.4		45.4		50.5	
	オフセット		オフセット		オフセット	
	0°	20°	0°	20°	0°	20°
16.0	6.7					
18.0	6.7		5.6			
20.0	6.7		5.6		3.3	
22.0	6.7		5.6		3.3	
24.0	6.7		5.6		3.3	
26.0	6.7		5.6		3.3	
28.0	6.7		5.6		3.3	
30.0	6.7		5.6		3.3	
32.0	6.7		5.6		3.3	
34.0	6.4	3.7	5.6		3.3	
36.0	5.9	3.5	5.6	3.6	3.3	
38.0	5.4	3.2	5.6	3.4	3.3	3.5
40.0	5.0	3.0	5.4	3.1	3.3	3.3
42.0	4.6	2.8	5.0	2.9	3.3	3.1
44.0	4.3	2.6	4.7	2.7	3.3	2.9
46.0	4.0	2.4	4.3	2.6	3.3	2.7
48.0	3.7	2.3	4.0	2.4	3.3	2.5
50.0	3.4	2.1	3.7	2.2	3.3	2.4
54.0	2.9	1.8	3.2	1.9	3.3	2.1
58.0	2.5	1.6	2.8	1.7	2.9	1.8
62.0	2.1		2.4	1.5	2.5	1.6
66.0	1.8		2.1		2.2	
70.0	1.5		1.8		1.8	
74.0			1.5		1.5	
θ(°)	40~ 84.5	62~ 84.5	40~ 84.5	62~ 84.5	44~ 84.5	65~ 84.5
標準フック	12.2t					
フック重量	440kg					
標準巻掛本数	1					

PS+油圧チルトジブ

カウンタウエイト 78t、アウトリガ張出幅 8.5m

PS+ブーム+2.0m+3.5m油圧チルトジブ

単位:t

ブーム長さ(m) 作業半径 (m)	40.4			45.4			50.5			55.6			60.0		
	オフセット			オフセット			オフセット			オフセット			オフセット		
	0°	20°	40°	0°	20°	40°	0°	20°	40°	0°	20°	40°	0°	20°	40°
8.0	58.6														
9.0	58.6	58.6		52.9											
10.0	58.6	58.6	53.9	52.0	48.4		34.9								
11.0	58.6	57.7	52.9	50.7	47.2	45.0	33.7	30.3		28.3					
12.0	58.6	56.5	51.9	49.5	46.2	44.1	32.6	29.4	27.4	27.3	25.1		26.0		
14.0	56.8	54.2	50.2	47.3	44.4	42.5	30.6	27.8	26.1	25.5	23.6	22.4	24.3	22.5	21.4
16.0	50.2	48.4	47.2	45.4	42.8	41.1	28.9	26.4	24.9	23.9	22.2	21.2	22.8	21.3	20.3
18.0	44.1	43.4	42.5	42.5	41.1	39.9	27.4	25.2	23.9	22.5	21.1	20.1	21.5	20.2	19.3
20.0	37.2	37.8	38.3	37.6	37.2	36.5	26.1	24.1	22.9	21.3	20.0	19.2	20.4	19.2	18.4
22.0	31.7	32.3	32.6	32.2	32.8	33.1	24.9	23.1	22.1	20.2	19.1	18.4	19.4	18.3	17.6
24.0	27.4	27.9	28.1	27.8	28.3	28.6	23.8	22.3	21.4	19.3	18.2	17.6	18.5	17.5	16.9
26.0	23.8	24.2	24.4	24.2	24.7	24.9	22.9	21.5	20.7	18.4	17.5	16.9	17.6	16.8	16.2
28.0	20.8	21.1	21.3	21.2	21.6	21.8	22.0	20.8	20.1	17.6	16.8	16.3	16.8	16.1	15.6
30.0	18.3	18.6	18.7	18.7	19.0	19.2	19.4	19.7	19.5	16.9	16.1	15.7	15.6	15.2	14.9
32.0	16.1	16.3	16.4	16.5	16.8	16.9	17.2	17.5	17.7	16.2	15.6	15.2	14.5	14.1	13.9
34.0	14.2	14.4	14.5	14.6	14.9	15.0	15.3	15.6	15.7	15.7	15.0	14.7	13.5	13.2	13.0
36.0	12.4	12.6		13.0	13.2	13.3	13.7	13.9	14.0	14.3	14.5	14.3	12.6	12.3	12.2
38.0	10.8	10.9		11.3	11.6	11.6	12.2	12.4	12.5	12.8	13.0	13.1	11.8	11.6	11.5
40.0	9.3	9.4		9.9	10.0		10.7	10.9	11.0	11.5	11.7	11.7	11.0	10.9	10.8
42.0	8.0			8.6	8.7		9.4	9.6	9.6	10.1	10.3	10.4	10.3	10.2	10.2
44.0	3.8			7.4	7.5		8.2	8.4		8.9	9.1	9.2	9.1	9.3	9.3
46.0				6.3	6.4		7.1	7.2		7.8	8.0	8.0	8.0	8.1	8.2
48.0				5.3			6.1	6.2		6.9	7.0		7.0	7.1	7.2
50.0							5.3	5.3		5.9	6.1		6.1	6.2	
54.0							2.5			4.4	4.4		4.5	4.5	
58.0										3.0			3.1	3.1	
62.0													1.9		
θ(°)	0~ 84.5	27~ 84.5	43~ 84.5	13~ 84.5	23~ 84.5	42~ 84.5	0~ 84.5	25~ 84.5	42~ 84.5	13~ 84.5	27~ 84.5	42~ 84.5	15~ 84.5	27~ 84.5	45~ 84.5
標準フック	80t						35t								
フック重量	1550kg						950kg								
標準巻掛本数	5						3								

カウンタウエイト 78t、アウトリガ張出幅 8.5m

PS+ブーム+2.0m+11.5m油圧チルトジブ

単位:t

ブーム長さ(m) 作業半径 (m)	40.4			45.4			50.5			55.6			60.0		
	オフセット			オフセット			オフセット			オフセット			オフセット		
	0°	20°	40°	0°	20°	40°	0°	20°	40°	0°	20°	40°	0°	20°	40°
10.0	45.4														
11.0	45.4			36.6											
12.0	44.8			36.6			27.9								
14.0	42.2	32.1		36.6	30.8		25.8			22.3			19.5		
16.0	39.8	30.6	24.5	36.6	29.6		24.0	19.0		20.7	17.0		19.5		
18.0	37.6	29.3	23.9	36.1	28.4	24.2	22.5	18.0	15.5	19.3	16.0		18.4	15.4	
20.0	35.3	28.1	23.3	33.9	27.4	23.5	21.1	17.1	14.9	18.1	15.2	13.5	17.3	14.6	
22.0	32.0	27.1	22.8	30.6	26.4	22.8	19.9	16.4	14.3	17.0	14.4	12.9	16.3	13.9	12.4
24.0	28.4	26.1	22.3	27.9	25.6	22.3	18.8	15.7	13.8	16.1	13.7	12.4	15.4	13.2	11.9
26.0	24.8	25.3	21.9	25.1	24.1	21.8	17.9	15.0	13.4	15.2	13.1	11.9	14.6	12.6	11.4
28.0	21.8	23.2	21.5	22.1	22.3	21.3	17.1	14.4	12.9	14.4	12.6	11.4	13.9	12.1	11.0
30.0	19.3	20.5	21.2	19.6	20.7	20.2	16.3	13.9	12.5	13.7	12.0	11.0	13.1	11.6	10.6
32.0	17.1	18.2	19.0	17.4	18.5	18.9	15.6	13.4	12.2	13.1	11.6	10.6	12.1	11.1	10.3
34.0	15.2	16.2	16.9	15.5	16.5	17.2	15.0	13.0	11.9	12.5	11.1	10.3	11.2	10.5	9.9
36.0	13.6	14.4	15.0	13.9	14.8	15.4	14.2	12.6	11.6	12.0	10.7	10.0	10.4	9.8	9.5
38.0	12.1	12.9	13.3	12.4	13.2	13.8	12.8	12.2	11.3	11.5	10.3	9.7	9.7	9.2	8.9
40.0	10.6	11.5	11.9	11.0	11.8	12.3	11.4	11.9	11.0	11.1	10.0	9.4	9.0	8.6	8.4
42.0	9.3	10.0	10.4	9.6	10.5	11.0	10.1	11.0	10.8	10.6	9.7	9.1	8.4	8.1	7.9
44.0	8.1	8.7		8.4	9.2	9.6	8.9	9.7	10.2	9.4	9.4	8.9	7.9	7.6	7.4
46.0	7.0	7.6		7.4	8.0	8.3	7.8	8.6	9.0	8.4	9.1	8.7	7.4	7.1	7.0
48.0	6.1	6.5		6.4	6.9		6.9	7.5	7.9	7.4	8.1	8.5	6.9	6.7	6.6
50.0	5.2			5.5	6.0		6.0	6.5	6.8	6.5	7.1	7.5	6.4	6.3	6.3
54.0				3.9	4.2		4.4	4.8		4.9	5.4	5.6	4.8	5.3	5.6
58.0							3.1	3.3		3.5	3.9		3.4	3.9	
62.0										2.4	2.6		2.3	2.6	
66.0													1.5		
θ(°)	17~ 83	28~ 84.5	44~ 84.5	20~ 83	24~ 84.5	44~ 84.5	22~ 83	26~ 84.5	43~ 84.5	24~ 83	28~ 84.5	43~ 84.5	32~ 83	28~ 84.5	48~ 84.5
標準フック	80t						35t								
フック重量	1550kg						950kg								
標準巻掛本数	4						3								

カウンタウエイト 78t、アウトリガ張出幅 8.5m

PS+ブーム+2.0m+17.5m油圧チルトジブ

単位:t

ブーム長さ(m) 作業半径 (m)	40.4			45.4			50.5			55.6			60.0		
	オフセット			オフセット			オフセット			オフセット			オフセット		
	0°	20°	40°	0°	20°	40°	0°	20°	40°	0°	20°	40°	0°	20°	40°
11.0	32.6														
12.0	32.6			28.2											
14.0	32.6			28.2			21.7								
16.0	31.2	21.3		28.2			21.0			16.9			14.4		
18.0	29.4	20.2		28.1	20.7		19.6	14.9		16.9			14.0		
20.0	27.9	19.2		26.9	19.8		18.3	14.1		15.9	12.7		13.6		
22.0	26.5	18.3	14.0	25.6	18.9		17.2	13.4		14.9	12.1		13.1	11.6	
24.0	25.2	17.5	13.6	24.5	18.0	13.8	16.2	12.8	11.0	14.0	11.5		12.7	11.1	
26.0	24.0	16.7	13.3	23.2	17.3	13.5	15.3	12.3	10.6	13.2	10.9	9.6	12.1	10.6	9.3
28.0	22.4	16.1	12.9	21.3	16.6	13.1	14.5	11.8	10.2	12.5	10.4	9.2	11.6	10.1	8.9
30.0	20.0	15.4	12.7	19.7	16.0	12.9	13.8	11.3	9.9	11.9	10.0	8.9	11.1	9.7	8.6
32.0	17.8	14.9	12.4	17.9	15.5	12.6	13.2	10.9	9.6	11.3	9.6	8.6	10.6	9.3	8.3
34.0	15.9	14.4	12.2	16.0	15.0	12.4	12.6	10.5	9.3	10.8	9.2	8.3	9.8	8.9	8.0
36.0	14.2	13.9	12.0	14.3	14.5	12.2	12.1	10.1	9.1	10.3	8.8	8.0	9.1	8.4	7.6
38.0	12.7	13.5	11.8	12.8	14.0	12.0	11.6	9.8	8.8	9.8	8.5	7.8	8.4	7.8	7.3
40.0	11.4	12.5	11.7	11.5	12.7	11.8	11.1	9.5	8.6	9.4	8.2	7.5	7.8	7.3	7.0
42.0	10.1	11.3	11.6	10.2	11.4	11.7	10.6	9.2	8.4	9.0	7.9	7.3	7.3	6.9	6.7
44.0	8.9	10.0	10.7	9.0	10.2	10.9	9.4	9.0	8.2	8.7	7.7	7.1	6.7	6.4	6.3
46.0	7.8	8.8	9.4	7.9	9.0	9.7	8.3	8.7	8.0	8.4	7.4	6.9	6.3	6.0	5.9
48.0	6.8	7.7	8.2	6.9	7.9	8.5	7.4	8.4	7.9	7.6	7.2	6.7	5.9	5.6	5.6
50.0	5.9	6.7		6.0	6.9	7.4	6.5	7.4	7.8	6.7	7.0	6.6	5.5	5.3	5.3
54.0	4.4	4.8		4.4	5.1		4.9	5.7	6.1	5.1	6.0	6.3	4.8	4.7	4.7
58.0				3.1	3.6		3.5	4.1		3.8	4.5	4.9	3.6	4.1	4.2
62.0				2.0			2.3	2.8		2.6	3.2		2.4	3.1	3.4
66.0										1.6	2.0			1.9	
θ(°)	23~83	28~84.5	44~84.5	11~83	30~84.5	48~84.5	26~83	31~84.5	47~84.5	28~83	32~84.5	47~84.5	40~83	39~84.5	46~84.5
標準フック重量	35t						35t								
標準巻掛本数	950kg						950kg								
	3						2								

カウンタウエイト 78t、アウトリガ張出幅 8.5m

PS+ブーム+2.0m+23.5m油圧チルトジブ

単位:t

ブーム長さ(m) 作業半径 (m)	40.4			45.4			50.5			55.6			60.0		
	オフセット			オフセット			オフセット			オフセット			オフセット		
	0°	20°	40°	0°	20°	40°	0°	20°	40°	0°	20°	40°	0°	20°	40°
12.0	24.7														
14.0	24.7			21.4			16.6								
16.0	24.7			21.4			16.6			12.7					
18.0	24.3			21.4			16.6			12.7			10.4		
20.0	23.0	14.4		21.4			16.1			12.7			10.0		
22.0	21.7	13.6		21.1	14.0		15.1	11.3		12.7			9.6		
24.0	20.1	12.9		20.1	13.3		14.1	10.8		12.4	9.8		9.2		
26.0	18.6	12.3	9.3	19.2	12.7		13.3	10.3		11.7	9.4		8.8	9.0	
28.0	17.3	11.7	9.0	18.4	12.1	9.1	12.6	9.9		11.0	8.9		8.3	8.6	
30.0	16.1	11.2	8.7	17.4	11.6	8.9	12.0	9.5	8.1	10.4	8.5	7.4	7.9	8.2	
32.0	15.1	10.7	8.5	16.3	11.2	8.6	11.4	9.1	7.8	9.9	8.1	7.1	7.4	7.7	6.5
34.0	14.2	10.3	8.3	15.3	10.7	8.4	10.8	8.7	7.6	9.4	7.8	6.9	7.0	7.3	6.2
36.0	13.4	9.9	8.1	14.4	10.3	8.2	10.3	8.4	7.3	8.9	7.5	6.6	6.6	6.8	5.9
38.0	12.6	9.6	7.9	13.3	10.0	8.1	9.9	8.1	7.1	8.5	7.2	6.4	6.1	6.5	5.7
40.0	12.0	9.2	7.7	12.0	9.6	7.9	9.5	7.8	6.9	8.1	6.9	6.2	5.8	6.1	5.4
42.0	10.7	8.9	7.6	10.7	9.3	7.7	9.1	7.6	6.7	7.8	6.7	6.0	5.4	5.8	5.1
44.0	9.5	8.6	7.5	9.5	9.0	7.6	8.7	7.3	6.6	7.5	6.4	5.8	5.0	5.5	4.9
46.0	8.4	8.4	7.4	8.4	8.7	7.5	8.4	7.1	6.4	7.2	6.2	5.6	4.7	5.1	4.7
48.0	7.4	8.1	7.3	7.4	8.5	7.4	7.6	6.9	6.3	6.9	6.0	5.5	4.4	4.8	4.5
50.0	6.5	7.7	7.2	6.5	7.8	7.3	6.7	6.7	6.1	6.6	5.8	5.3	4.1	4.4	4.3
54.0	4.9	5.8	6.4	4.9	6.0	6.7	5.1	6.3	5.9	5.3	5.4	5.0	3.5	3.9	3.9
58.0	3.6	4.2		3.6	4.4	4.9	3.8	4.7	5.3	4.0	5.0	4.8	3.0	3.4	3.4
62.0	2.4			2.4	3.0		2.6	3.4	3.8	2.8	3.7	4.2	2.5	2.9	3.0
66.0					1.7		1.6	2.2		1.8	2.5	2.8	1.5	2.4	2.6
θ(°)	16~83	33~84.5	45~84.5	28~83	25~84.5	45~84.5	29~83	35~84.5	45~84.5	36~83	42~84.5	45~84.5	41~83	47~84.5	50~84.5
標準フック重量	35t						35t								
標準巻掛本数	950kg						950kg								
	3						2								

PS+油圧チルトジブ

カウンタウエイト 78t、アウトリガ張出幅 8.5m

PS+ブーム+2.0m+29.5m油圧チルトジブ

単位:t

ブーム長さ(m) 作業半径 (m)	40.4			45.4			50.5			55.6			60.0			
	オフセット			オフセット			オフセット			オフセット			オフセット			
	0°	20°	40°	0°	20°	40°	0°	20°	40°	0°	20°	40°	0°	20°	40°	
14.0	18.7			16.1												
16.0	18.7			16.1			12.4									
18.0	18.7			16.1			12.4							7.0		
20.0	18.7			16.1			12.4			8.7				6.7		
22.0	17.8			16.1			12.4			8.7				6.3		
24.0	16.5	10.2		16.1	10.5		12.4			8.7				6.0		
26.0	15.2	9.6		15.7	9.9		11.8	8.9		8.6				5.6		
28.0	14.1	9.1		15.1	9.4		11.1	8.5		8.4	8.0			5.3		
30.0	13.1	8.7		14.1	9.0		10.5	8.1		8.3	7.6			4.9	6.7	
32.0	12.2	8.3	6.2	13.1	8.6	6.3	10.0	7.8		8.1	7.3			4.6	6.3	
34.0	11.4	7.9	6.0	12.3	8.2	6.1	9.5	7.5	6.2	7.9	6.9			4.2	5.9	
36.0	10.7	7.6	5.9	11.5	7.9	6.0	9.0	7.2	6.0	7.7	6.6	5.8		3.9	5.5	
38.0	10.0	7.2	5.7	10.9	7.5	5.8	8.6	6.9	5.9	7.5	6.4	5.6		3.5	5.2	4.4
40.0	9.5	6.9	5.5	10.2	7.2	5.6	8.2	6.6	5.7	7.3	6.1	5.4		3.2	4.9	4.2
42.0	8.9	6.7	5.4	9.7	7.0	5.5	7.8	6.4	5.6	7.0	5.8	5.2		2.9	4.6	4.0
44.0	8.5	6.4	5.3	9.2	6.7	5.4	7.5	6.2	5.4	6.7	5.6	5.0		2.6	4.3	3.8
46.0	8.0	6.2	5.1	8.7	6.5	5.2	7.2	6.0	5.2	6.4	5.4	4.8		2.3	4.1	3.6
48.0	7.6	6.0	5.0	7.7	6.3	5.1	6.9	5.8	5.1	6.1	5.2	4.6		2.1	3.9	3.4
50.0	6.8	5.8	5.0	6.7	6.1	5.0	6.7	5.6	5.0	5.9	5.0	4.4		1.8	3.6	3.3
54.0	5.2	5.4	4.8	5.1	5.7	4.9	5.3	5.2	4.7	5.3	4.5	4.0			3.2	3.0
58.0	3.9	5.0	4.8	3.8	5.0	4.8	3.9	4.9	4.4	4.2	4.1	3.7			2.7	2.7
62.0	2.7	3.5		2.6	3.6	4.2	2.7	3.8	4.2	3.0	3.8	3.4			2.3	2.4
66.0	1.7	2.2		1.6	2.4		1.7	2.6	3.2	2.0	3.0	3.2			1.9	2.0
70.0								1.6			1.9	2.4			1.6	1.7
θ(°)	21~ 83	29~ 84.5	49~ 84.5	31~ 83	39~ 84.5	49~ 84.5	37~ 83	39~ 84.5	49~ 84.5	42~ 83	45~ 84.5	49~ 84.5	59~ 83	49~ 84.5	53~ 84.5	
標準フック	35t												12.2t			
フック重量	950kg												440kg			
標準巻掛本数	2												1			

カウンタウエイト 78t、アウトリガ張出幅 8.5m

PS+ブーム+2.0m+35.5m油圧チルトジブ

単位:t

ブーム長さ(m) 作業半径 (m)	40.4			45.4			50.5			55.6			60.0				
	オフセット			オフセット			オフセット			オフセット			オフセット				
	0°	20°	40°	0°	20°	40°	0°	20°	40°	0°	20°	40°	0°	20°	40°		
14.0	14.1																
16.0	14.1				12.2												
18.0	14.1				12.2			8.8									
20.0	14.1				12.2			8.8			6.1				4.4		
22.0	14.1				12.2			8.8			6.1				4.2		
24.0	13.9				12.2			8.8			6.1				3.8		
26.0	13.0	7.9			12.2			8.8			6.0				3.5		
28.0	12.0	7.5			12.2	7.7		8.8			5.8				3.2		
30.0	11.1	7.1			11.8	7.3		8.8	7.4		5.7				2.9		
32.0	10.3	6.7			11.1	6.9		8.8	7.1		5.5	6.5			2.6	5.4	
34.0	9.6	6.4			10.3	6.6		8.8	6.8		5.3	6.2			2.2	5.0	
36.0	8.9	6.1	4.5		9.7	6.3		8.3	6.5		5.2	5.9			1.9	4.7	
38.0	8.4	5.8	4.3		9.0	6.0	4.4		7.9	6.2		5.0	5.6		1.6	4.4	
40.0	7.9	5.5	4.2		8.5	5.7	4.2		7.5	6.0	4.5	4.8	5.4			4.1	
42.0	7.4	5.3	4.0		8.0	5.5	4.1		7.2	5.7	4.4	4.6	5.1	4.4		3.9	3.3
44.0	7.0	5.0	3.9		7.5	5.3	4.0		6.9	5.5	4.3	4.3	4.9	4.2		3.6	3.1
46.0	6.6	4.8	3.8		7.1	5.0	3.9		6.6	5.3	4.1	4.1	4.6	4.0		3.4	2.9
48.0	6.2	4.6	3.7		6.7	4.8	3.7		6.3	5.1	4.0	3.9	4.3	3.8		3.2	2.7
50.0	5.9	4.4	3.6		6.4	4.7	3.7		6.0	4.9	3.9	3.7	4.1	3.6		3.0	2.6
54.0	5.3	4.1	3.4		5.5	4.3	3.5		5.6	4.5	3.7	3.2	3.7	3.2		2.6	2.3
58.0	4.3	3.8	3.3		4.1	4.0	3.3		4.4	4.1	3.6	2.7	3.3	2.9		2.3	2.0
62.0	3.1	3.6	3.2		2.9	3.8	3.2		3.2	3.8	3.4	2.3	3.0	2.6		1.9	1.8
66.0	2.1	3.0	3.2		1.9	3.0	3.2		2.2	3.4	3.2	1.8	2.7	2.4			1.6
70.0		1.9				1.9	2.5			2.3	3.0		2.4	2.2			
74.0										1.8		1.5	2.0				
θ(°)	32~ 83	34~ 84.5	46~ 84.5	38~ 83	42~ 84.5	47~ 84.5	43~ 83	47~ 84.5	47~ 84.5	47~ 83	47~ 84.5	48~ 84.5	53~ 84.5	70~ 83	61~ 84.5	63~ 84.5	
標準フック	35t												12.2t				
フック重量	950kg												440kg				
標準巻掛本数	2												1				

カウンタウエイト 78t、アウトリガ張出幅 8.5m

PS+ブーム+2.0m+41.5m油圧チルトジブ

単位:t

ブーム長さ(m) 作業半径 (m)	40.4			45.4			50.5			55.6			60.0		
	オフセット			オフセット			オフセット			オフセット			オフセット		
	0°	20°	40°	0°	20°	40°	0°	20°	40°	0°	20°	40°	0°	20°	40°
16.0	10.1			8.6											
18.0	10.1			8.6			6.0								
20.0	10.1			8.6			6.0					3.5			
22.0	10.1			8.6			6.0					3.5			1.9
24.0	10.1			8.6			6.0					3.5			1.6
26.0	10.1			8.6			6.0					3.4			
28.0	10.1			8.6			6.0					3.2			
30.0	9.5	5.8		8.6			6.0					3.1			
32.0	8.8	5.4		8.6	5.6		6.0					2.9			
34.0	8.2	5.1		8.6	5.3		6.0	5.4				2.8			
36.0	7.6	4.8		8.2	5.0		6.0	5.1				2.6	4.8		3.1
38.0	7.0	4.5		7.6	4.7		6.0	4.9				2.4	4.6		3.1
40.0	6.5	4.2		7.1	4.4		6.0	4.6				2.2	4.3		3.1
42.0	6.1	4.0	2.8	6.6	4.2		6.0	4.4				2.0	4.0		2.9
44.0	5.7	3.8	2.6	6.2	4.0	2.7	5.9	4.1				1.8	3.7		2.7
46.0	5.3	3.6	2.5	5.8	3.8	2.6	5.6	3.9	2.6			1.6	3.5		2.5
48.0	4.9	3.4	2.4	5.4	3.6	2.5	5.3	3.7	2.5			3.2	2.6		2.3
50.0	4.6	3.2	2.3	5.1	3.4	2.4	5.0	3.6	2.4			3.0	2.5		2.1
54.0	4.1	2.9	2.1	4.5	3.1	2.2	4.4	3.2	2.3			2.6	2.2		1.7
58.0	3.6	2.6	2.0	4.0	2.8	2.0	3.9	2.9	2.1			2.3	1.9		
62.0	3.2	2.3	1.8	3.0	2.5	1.9	3.0	2.7	2.0			1.9	1.6		
66.0	2.1	2.1	1.7	2.0	2.3	1.8	2.0	2.4	1.8			1.6			
70.0		1.9	1.7		2.1	1.7		2.1	1.8						
74.0						1.7			1.6						
θ(°)	39~ 83	44~ 84.5	51~ 84.5	44~ 83	49~ 84.5	51~ 84.5	47~ 83	54~ 84.5	56~ 84.5	65~ 83	60~ 84.5	70~ 84.5	80~ 83	70~ 84.5	80~ 84.5
標準フック	12.2t														
フック重量	440kg														
標準巻掛本数	1														

カウンタウエイト 78t、アウトリガ張出幅 8.5m

PS+ブーム+2.0m+47.5m油圧チルトジブ

単位:t

ブーム長さ(m) 作業半径 (m)	40.4		45.4		50.5	
	オフセット		オフセット		オフセット	
	0°	20°	0°	20°	0°	20°
16.0	6.7					
18.0	6.7		5.6			
20.0	6.7		5.6		3.3	
22.0	6.7		5.6		3.3	
24.0	6.7		5.6		3.3	
26.0	6.7		5.6		3.3	
28.0	6.7		5.6		3.3	
30.0	6.7		5.6		3.3	
32.0	6.7		5.6		3.3	
34.0	6.4	3.7	5.6		3.3	
36.0	5.9	3.5	5.6	3.6	3.3	
38.0	5.4	3.2	5.6	3.4	3.3	3.5
40.0	5.0	3.0	5.4	3.1	3.3	3.3
42.0	4.6	2.8	5.0	2.9	3.3	3.1
44.0	4.3	2.6	4.7	2.7	3.3	2.9
46.0	4.0	2.4	4.3	2.6	3.3	2.7
48.0	3.7	2.3	4.0	2.4	3.3	2.5
50.0	3.4	2.1	3.7	2.2	3.3	2.4
54.0	2.9	1.8	3.2	1.9	3.3	2.1
58.0	2.5	1.6	2.8	1.7	2.9	1.8
62.0	2.1		2.4	1.5	2.5	1.6
66.0	1.8		2.0		2.0	
θ(°)	44~ 84.5	62~ 84.5	48~ 84.5	62~ 84.5	51~ 84.5	65~ 84.5
標準フック	12.2t					
フック重量	440kg					
標準巻掛本数	1					

PS+油圧チルトジブ

カウンタウエイト 78t、アウトリガ張出幅 8.0m

PS+ブーム+2.0m+3.5m油圧チルトジブ

単位:t

ブーム長さ(m) 作業半径 (m)	40.4			45.4			50.5			55.6			60.0		
	オフセット			オフセット			オフセット			オフセット			オフセット		
	0°	20°	40°	0°	20°	40°	0°	20°	40°	0°	20°	40°	0°	20°	40°
8.0	58.6														
9.0	58.6	58.6		52.9											
10.0	58.6	58.6	53.9	52.0	48.4		34.9								
11.0	58.6	57.7	52.9	50.7	47.2	45.0	33.7	30.3		28.3					
12.0	58.6	56.5	51.9	49.5	46.2	44.1	32.6	29.4	27.4	27.3	25.1		26.0		
14.0	56.8	54.2	50.2	47.3	44.4	42.5	30.6	27.8	26.1	25.5	23.6	22.4	24.3	22.5	21.4
16.0	50.2	48.4	47.2	45.4	42.8	41.1	28.9	26.4	24.9	23.9	22.2	21.2	22.8	21.3	20.3
18.0	42.7	43.4	42.5	42.5	41.1	39.9	27.4	25.2	23.9	22.5	21.1	20.1	21.5	20.2	19.3
20.0	35.7	36.4	36.8	36.2	36.9	36.5	26.1	24.1	22.9	21.3	20.0	19.2	20.4	19.2	18.4
22.0	30.4	30.9	31.3	30.8	31.4	31.8	24.9	23.1	22.1	20.2	19.1	18.4	19.4	18.3	17.6
24.0	26.1	26.5	26.8	26.5	27.0	27.3	23.8	22.3	21.4	19.3	18.2	17.6	18.5	17.5	16.9
26.0	22.5	23.0	23.2	23.0	23.4	23.7	22.9	21.5	20.7	18.4	17.5	16.9	17.6	16.8	16.2
28.0	19.6	20.0	20.1	20.1	20.4	20.6	20.8	20.8	20.1	17.6	16.8	16.3	16.8	16.1	15.6
30.0	17.1	17.4	17.6	17.6	17.9	18.1	18.3	18.6	18.8	16.9	16.1	15.7	15.6	15.2	14.9
32.0	15.0	15.3	15.4	15.5	15.7	15.9	16.2	16.5	16.6	16.2	15.6	15.2	14.5	14.1	13.9
34.0	13.2	13.4	13.4	13.6	13.9	14.0	14.3	14.6	14.7	14.9	15.0	14.7	13.5	13.2	13.0
36.0	11.4	11.6		11.9	12.2	12.3	12.7	12.9	13.0	13.3	13.5	13.7	12.6	12.3	12.2
38.0	9.7	9.9		10.3	10.5	10.6	11.2	11.4	11.5	11.9	12.1	12.2	11.8	11.6	11.5
40.0	8.3	8.4		8.9	9.1		9.8	10.0	10.0	10.5	10.7	10.8	10.6	10.9	10.8
42.0	7.0			7.6	7.8		8.5	8.7	8.7	9.2	9.4	9.5	9.3	9.6	9.7
44.0	3.8			6.5	6.6		7.3	7.5		8.0	8.2	8.3	8.2	8.4	8.5
46.0				5.4	5.5		6.3	6.4		7.0	7.1	7.2	7.1	7.3	7.4
48.0				4.5			5.3	5.4		6.0	6.2		6.1	6.3	6.4
50.0							4.5	4.5		5.2	5.3		5.3	5.4	
54.0							2.5			3.6	3.7		3.7	3.8	
58.0										2.3			2.4	2.5	
θ(°)	0~ 84.5	27~ 84.5	43~ 84.5	13~ 84.5	23~ 84.5	42~ 84.5	0~ 84.5	25~ 84.5	42~ 84.5	13~ 84.5	27~ 84.5	42~ 84.5	27~ 84.5	27~ 84.5	45~ 84.5
標準フック	80t						35t								
フック重量	1550kg						950kg								
標準巻掛本数	5						3								

カウンタウエイト 78t、アウトリガ張出幅 8.0m

PS+ブーム+2.0m+11.5m油圧チルトジブ

単位:t

ブーム長さ(m) 作業半径 (m)	40.4			45.4			50.5			55.6			60.0		
	オフセット			オフセット			オフセット			オフセット			オフセット		
	0°	20°	40°	0°	20°	40°	0°	20°	40°	0°	20°	40°	0°	20°	40°
10.0	45.4														
11.0	45.4			36.6											
12.0	44.8			36.6			27.9								
14.0	42.2	32.1		36.6	30.8		25.8			22.3			19.5		
16.0	39.8	30.6	24.5	36.6	29.6		24.0	19.0		20.7	17.0		19.5		
18.0	37.6	29.3	23.9	36.1	28.4	24.2	22.5	18.0	15.5	19.3	16.0		18.4	15.4	
20.0	35.3	28.1	23.3	33.9	27.4	23.5	21.1	17.1	14.9	18.1	15.2	13.5	17.3	14.6	
22.0	31.4	27.1	22.8	30.6	26.4	22.8	19.9	16.4	14.3	17.0	14.4	12.9	16.3	13.9	12.4
24.0	27.1	26.1	22.3	27.5	25.6	22.3	18.8	15.7	13.8	16.1	13.7	12.4	15.4	13.2	11.9
26.0	23.6	25.1	21.9	23.9	24.1	21.8	17.9	15.0	13.4	15.2	13.1	11.9	14.6	12.6	11.4
28.0	20.7	22.0	21.5	21.0	22.3	21.3	17.1	14.4	12.9	14.4	12.6	11.4	13.9	12.1	11.0
30.0	18.2	19.4	20.3	18.5	19.7	20.2	16.3	13.9	12.5	13.7	12.0	11.0	13.1	11.6	10.6
32.0	16.0	17.1	17.9	16.4	17.5	18.3	15.6	13.4	12.2	13.1	11.6	10.6	12.1	11.1	10.3
34.0	14.2	15.2	15.9	14.5	15.5	16.3	14.9	13.0	11.9	12.5	11.1	10.3	11.2	10.5	9.9
36.0	12.6	13.5	14.0	12.9	13.8	14.5	13.3	12.6	11.6	12.0	10.7	10.0	10.4	9.8	9.5
38.0	11.1	11.9	12.4	11.4	12.3	12.9	11.8	12.2	11.3	11.5	10.3	9.7	9.7	9.2	8.9
40.0	9.7	10.5	11.0	10.0	10.9	11.4	10.5	11.3	11.0	11.0	10.0	9.4	9.0	8.6	8.4
42.0	8.4	9.1	9.5	8.7	9.6	10.1	9.2	10.1	10.6	9.7	9.7	9.1	8.4	8.1	7.9
44.0	7.2	7.9		7.6	8.3	8.7	8.0	8.8	9.4	8.6	9.4	8.9	7.9	7.6	7.4
46.0	6.2	6.7		6.5	7.2	7.5	7.0	7.7	8.1	7.5	8.3	8.7	7.4	7.1	7.0
48.0	5.3	5.7		5.6	6.1		6.1	6.7	7.0	6.6	7.3	7.7	6.5	6.7	6.6
50.0	4.4			4.7	5.2		5.2	5.8	6.0	5.7	6.3	6.7	5.6	6.3	6.3
54.0				3.2	3.5		3.7	4.1		4.2	4.7	4.9	4.1	4.6	4.9
58.0							2.4	2.7		2.9	3.2		2.7	3.2	
62.0										1.7	2.0		1.6	2.0	
θ(°)	17~ 83	28~ 84.5	44~ 84.5	20~ 83	24~ 84.5	44~ 84.5	22~ 83	26~ 84.5	43~ 84.5	24~ 83	28~ 84.5	43~ 84.5	32~ 83	35~ 84.5	48~ 84.5
標準フック	80t						35t								
フック重量	1550kg						950kg								
標準巻掛本数	4						3								

カウンタウエイト 78t、アウトリガ張出幅 8.0m

PS+ブーム+2.0m+17.5m油圧チルトジブ

単位:t

ブーム長さ(m) 作業半径 (m)	40.4			45.4			50.5			55.6			60.0		
	オフセット			オフセット			オフセット			オフセット			オフセット		
	0°	20°	40°	0°	20°	40°	0°	20°	40°	0°	20°	40°	0°	20°	40°
11.0	32.6														
12.0	32.6			28.2											
14.0	32.6			28.2			21.7								
16.0	31.2	21.3		28.2			21.0			16.9			14.4		
18.0	29.4	20.2		28.1	20.7		19.6	14.9		16.9			14.0		
20.0	27.9	19.2		26.9	19.8		18.3	14.1		15.9	12.7		13.6		
22.0	26.5	18.3	14.0	25.6	18.9		17.2	13.4		14.9	12.1		13.1	11.6	
24.0	25.2	17.5	13.6	24.5	18.0	13.8	16.2	12.8	11.0	14.0	11.5		12.7	11.1	
26.0	24.0	16.7	13.3	23.2	17.3	13.5	15.3	12.3	10.6	13.2	10.9	9.6	12.1	10.6	9.3
28.0	21.4	16.1	12.9	21.3	16.6	13.1	14.5	11.8	10.2	12.5	10.4	9.2	11.6	10.1	8.9
30.0	18.9	15.4	12.7	19.0	16.0	12.9	13.8	11.3	9.9	11.9	10.0	8.9	11.1	9.7	8.6
32.0	16.8	14.9	12.4	16.8	15.5	12.6	13.2	10.9	9.6	11.3	9.6	8.6	10.6	9.3	8.3
34.0	14.9	14.4	12.2	15.0	15.0	12.4	12.6	10.5	9.3	10.8	9.2	8.3	9.8	8.9	8.0
36.0	13.3	13.9	12.0	13.3	14.5	12.2	12.1	10.1	9.1	10.3	8.8	8.0	9.1	8.4	7.6
38.0	11.8	13.1	11.8	11.9	13.2	12.0	11.6	9.8	8.8	9.8	8.5	7.8	8.4	7.8	7.3
40.0	10.5	11.7	11.7	10.6	11.8	11.0	11.0	9.5	8.6	9.4	8.2	7.5	7.8	7.3	7.0
42.0	9.2	10.4	11.1	9.3	10.6	11.3	9.7	9.2	8.4	9.0	7.9	7.3	7.3	6.9	6.7
44.0	8.0	9.2	9.9	8.1	9.3	10.1	8.6	9.0	8.2	8.7	7.7	7.1	6.7	6.4	6.3
46.0	7.0	8.0	8.6	7.1	8.2	8.9	7.5	8.7	8.0	7.8	7.4	6.9	6.3	6.0	5.9
48.0	6.0	6.9	7.4	6.1	7.1	7.7	6.6	7.6	7.9	6.8	7.2	6.7	5.9	5.6	5.6
50.0	5.2	5.9		5.2	6.1	6.7	5.7	6.7	7.3	6.0	7.0	6.6	5.5	5.3	5.3
54.0	3.6	4.1		3.7	4.4		4.1	4.9	5.4	4.4	5.3	5.8	4.2	4.7	4.7
58.0				2.4	2.9		2.8	3.5		3.1	3.8	4.2	2.9	3.7	4.2
62.0							1.7	2.1		2.0	2.5		1.8	2.5	2.8
θ(°)	23~ 83	28~ 84.5	44~ 84.5	25~ 83	30~ 84.5	48~ 84.5	26~ 83	31~ 84.5	47~ 84.5	34~ 83	39~ 84.5	47~ 84.5	40~ 83	44~ 84.5	46~ 84.5
標準フック	35t						35t								
フック重量	950kg						950kg								
標準巻掛本数	3						2								

カウンタウエイト 78t、アウトリガ張出幅 8.0m

PS+ブーム+2.0m+23.5m油圧チルトジブ

単位:t

ブーム長さ(m) 作業半径 (m)	40.4			45.4			50.5			55.6			60.0		
	オフセット			オフセット			オフセット			オフセット			オフセット		
	0°	20°	40°	0°	20°	40°	0°	20°	40°	0°	20°	40°	0°	20°	40°
12.0	24.7														
14.0	24.7			21.4			16.6								
16.0	24.7			21.4			16.6			12.7					
18.0	24.3			21.4			16.6			12.7			10.4		
20.0	23.0	14.4		21.4			16.1			12.7			10.0		
22.0	21.7	13.6		21.1	14.0		15.1	11.3		12.7			9.6		
24.0	20.1	12.9		20.1	13.3		14.1	10.8		12.4	9.8		9.2		
26.0	18.6	12.3	9.3	19.2	12.7		13.3	10.3		11.7	9.4		8.8	9.0	
28.0	17.3	11.7	9.0	18.4	12.1	9.1	12.6	9.9		11.0	8.9		8.3	8.6	
30.0	16.1	11.2	8.7	17.4	11.6	8.9	12.0	9.5	8.1	10.4	8.5	7.4	7.9	8.2	
32.0	15.1	10.7	8.5	16.3	11.2	8.6	11.4	9.1	7.8	9.9	8.1	7.1	7.4	7.7	6.5
34.0	14.2	10.3	8.3	15.3	10.7	8.4	10.8	8.7	7.6	9.4	7.8	6.9	7.0	7.3	6.2
36.0	13.4	9.9	8.1	13.8	10.3	8.2	10.3	8.4	7.3	8.9	7.5	6.6	6.6	6.8	5.9
38.0	12.4	9.6	7.9	12.4	10.0	8.1	9.9	8.1	7.1	8.5	7.2	6.4	6.1	6.5	5.7
40.0	11.1	9.2	7.7	11.1	9.6	7.9	9.5	7.8	6.9	8.1	6.9	6.2	5.8	6.1	5.4
42.0	9.8	8.9	7.6	9.8	9.3	7.7	9.1	7.6	6.7	7.8	6.7	6.0	5.4	5.8	5.1
44.0	8.7	8.6	7.5	8.7	9.0	7.6	8.7	7.3	6.6	7.5	6.4	5.8	5.0	5.5	4.9
46.0	7.6	8.4	7.4	7.6	8.7	7.5	7.8	7.1	6.4	7.2	6.2	5.6	4.7	5.1	4.7
48.0	6.6	8.0	7.3	6.6	8.1	7.4	6.8	6.9	6.3	6.9	6.0	5.5	4.4	4.8	4.5
50.0	5.8	6.9	7.2	5.7	7.1	7.3	6.0	6.7	6.1	6.1	5.8	5.3	4.1	4.4	4.3
54.0	4.2	5.1	5.6	4.2	5.3	6.0	4.4	5.6	5.9	4.6	5.4	5.0	3.5	3.9	3.9
58.0	2.9	3.6		2.9	3.8	4.2	3.1	4.1	4.7	3.3	4.3	4.8	3.0	3.4	3.4
62.0	1.8			1.8	2.4		2.0	2.8	3.2	2.2	3.0	3.6	1.9	2.9	3.0
66.0								1.6				1.9	2.3	1.8	2.3
θ(°)	16~ 83	33~ 84.5	45~ 84.5	28~ 83	35~ 84.5	45~ 84.5	35~ 83	35~ 84.5	45~ 84.5	41~ 83	42~ 84.5	45~ 84.5	45~ 83	47~ 84.5	50~ 84.5
標準フック	35t						35t								
フック重量	950kg						950kg								
標準巻掛本数	3						2								

PS+油圧チルトジブ

カウンタウエイト 78t、アウトリガ張出幅 8.0m

PS+ブーム+2.0m+29.5m油圧チルトジブ

単位:t

ブーム長さ(m) 作業半径 (m)	40.4			45.4			50.5			55.6			60.0		
	オフセット			オフセット			オフセット			オフセット			オフセット		
	0°	20°	40°	0°	20°	40°	0°	20°	40°	0°	20°	40°	0°	20°	40°
14.0	18.7			16.1											
16.0	18.7			16.1			12.4								
18.0	18.7			16.1			12.4						7.0		
20.0	18.7			16.1			12.4			8.7			6.7		
22.0	17.8			16.1			12.4			8.7			6.3		
24.0	16.5	10.2		16.1	10.5		12.4			8.7			6.0		
26.0	15.2	9.6		15.7	9.9		11.8	8.9		8.6			5.6		
28.0	14.1	9.1		15.1	9.4		11.1	8.5		8.4	8.0		5.3		
30.0	13.1	8.7		14.1	9.0		10.5	8.1		8.3	7.6		4.9	6.7	
32.0	12.2	8.3	6.2	13.1	8.6	6.3	10.0	7.8		8.1	7.3		4.6	6.3	
34.0	11.4	7.9	6.0	12.3	8.2	6.1	9.5	7.5	6.2	7.9	6.9		4.2	5.9	
36.0	10.7	7.6	5.9	11.5	7.9	6.0	9.0	7.2	6.0	7.7	6.6	5.8	3.9	5.5	
38.0	10.0	7.2	5.7	10.9	7.5	5.8	8.6	6.9	5.9	7.5	6.4	5.6	3.5	5.2	4.4
40.0	9.5	6.9	5.5	10.2	7.2	5.6	8.2	6.6	5.7	7.3	6.1	5.4	3.2	4.9	4.2
42.0	8.9	6.7	5.4	9.7	7.0	5.5	7.8	6.4	5.6	7.0	5.8	5.2	2.9	4.6	4.0
44.0	8.5	6.4	5.3	8.9	6.7	5.4	7.5	6.2	5.4	6.7	5.6	5.0	2.6	4.3	3.8
46.0	7.9	6.2	5.1	7.8	6.5	5.2	7.2	6.0	5.2	6.4	5.4	4.8	2.3	4.1	3.6
48.0	7.0	6.0	5.0	6.9	6.3	5.1	6.9	5.8	5.1	6.1	5.2	4.6	2.1	3.9	3.4
50.0	6.1	5.8	5.0	6.0	6.1	5.0	6.1	5.6	5.0	5.9	5.0	4.4	1.8	3.6	3.3
54.0	4.5	5.4	4.8	4.4	5.7	4.9	4.6	5.2	4.7	4.9	4.5	4.0		3.2	3.0
58.0	3.2	4.3	4.8	3.1	4.4	4.8	3.2	4.6	4.4	3.6	4.1	3.7		2.7	2.7
62.0	2.1	2.9		2.0	3.0	3.6	2.1	3.2	4.0	2.4	3.6	3.4		2.3	2.4
66.0		1.6			1.8			2.1	2.6		2.4	3.1		1.9	2.0
70.0												1.9			1.7
θ(°)	29~ 83	29~ 84.5	49~ 84.5	36~ 83	39~ 84.5	49~ 84.5	42~ 83	45~ 84.5	49~ 84.5	46~ 83	50~ 84.5	49~ 84.5	59~ 83	53~ 84.5	53~ 84.5
標準フック	35t												12.2t		
フック重量	950kg												440kg		
標準巻掛本数	2												1		

カウンタウエイト 78t、アウトリガ張出幅 8.0m

PS+ブーム+2.0m+35.5m油圧チルトジブ

単位:t

ブーム長さ(m) 作業半径 (m)	40.4			45.4			50.5			55.6			60.0		
	オフセット			オフセット			オフセット			オフセット			オフセット		
	0°	20°	40°	0°	20°	40°	0°	20°	40°	0°	20°	40°	0°	20°	40°
14.0	14.1														
16.0	14.1			12.2											
18.0	14.1			12.2			8.8								
20.0	14.1			12.2			8.8			6.1			4.4		
22.0	14.1			12.2			8.8			6.1			4.2		
24.0	13.9			12.2			8.8			6.1			3.8		
26.0	13.0	7.9		12.2			8.8			6.0			3.5		
28.0	12.0	7.5		12.2	7.7		8.8			5.8			3.2		
30.0	11.1	7.1		11.8	7.3		8.8	7.4		5.7			2.9		
32.0	10.3	6.7		11.1	6.9		8.8	7.1		5.5	6.5		2.6	5.4	
34.0	9.6	6.4		10.3	6.6		8.8	6.8		5.3	6.2		2.2	5.0	
36.0	8.9	6.1	4.5	9.7	6.3		8.3	6.5		5.2	5.9		1.9	4.7	
38.0	8.4	5.8	4.3	9.0	6.0	4.4	7.9	6.2		5.0	5.6		1.6	4.4	
40.0	7.9	5.5	4.2	8.5	5.7	4.2	7.5	6.0	4.5	4.8	5.4			4.1	
42.0	7.4	5.3	4.0	8.0	5.5	4.1	7.2	5.7	4.4	4.6	5.1	4.4		3.9	3.3
44.0	7.0	5.0	3.9	7.5	5.3	4.0	6.9	5.5	4.3	4.3	4.9	4.2		3.6	3.1
46.0	6.6	4.8	3.8	7.1	5.0	3.9	6.6	5.3	4.1	4.1	4.6	4.0		3.4	2.9
48.0	6.2	4.6	3.7	6.7	4.8	3.7	6.3	5.1	4.0	3.9	4.3	3.8		3.2	2.7
50.0	5.9	4.4	3.6	6.3	4.7	3.7	6.0	4.9	3.9	3.7	4.1	3.6		3.0	2.6
54.0	4.9	4.1	3.4	4.8	4.3	3.5	5.1	4.5	3.7	3.2	3.7	3.2		2.6	2.3
58.0	3.6	3.8	3.3	3.5	4.0	3.3	3.7	4.1	3.6	2.7	3.3	2.9		2.3	2.0
62.0	2.5	3.6	3.2	2.3	3.7	3.2	2.6	3.8	3.4	2.3	3.0	2.6		1.9	1.8
66.0	1.5	2.5	3.0		2.5	3.2	1.6	2.8	3.2	1.6	2.7	2.4			1.6
70.0						1.9		1.8	2.5		1.9	2.2			
θ(°)	32~ 83	41~ 84.5	46~ 84.5	42~ 83	47~ 84.5	47~ 84.5	43~ 83	47~ 84.5	53~ 84.5	47~ 83	52~ 84.5	57~ 84.5	70~ 83	61~ 84.5	63~ 84.5
標準フック	35t												12.2t		
フック重量	950kg												440kg		
標準巻掛本数	2												1		

カウンタウエイト 78t、アウトリガ張出幅 8.0m

PS+ブーム+2.0m+41.5m油圧チルトジブ

単位:t

ブーム長さ(m) 作業半径 (m)	40.4			45.4			50.5			55.6			60.0		
	オフセット			オフセット			オフセット			オフセット			オフセット		
	0°	20°	40°	0°	20°	40°	0°	20°	40°	0°	20°	40°	0°	20°	40°
16.0	10.1			8.6											
18.0	10.1			8.6			6.0								
20.0	10.1			8.6			6.0					3.5			
22.0	10.1			8.6			6.0					3.5		1.9	
24.0	10.1			8.6			6.0					3.5		1.6	
26.0	10.1			8.6			6.0					3.4			
28.0	10.1			8.6			6.0					3.2			
30.0	9.5	5.8		8.6			6.0					3.1			
32.0	8.8	5.4		8.6	5.6		6.0					2.9			
34.0	8.2	5.1		8.6	5.3		6.0	5.4				2.8			
36.0	7.6	4.8		8.2	5.0		6.0	5.1				2.6	4.8		3.1
38.0	7.0	4.5		7.6	4.7		6.0	4.9				2.4	4.6		3.1
40.0	6.5	4.2		7.1	4.4		6.0	4.6				2.2	4.3		3.1
42.0	6.1	4.0	2.8	6.6	4.2		6.0	4.4				2.0	4.0		2.9
44.0	5.7	3.8	2.6	6.2	4.0	2.7	5.9	4.1				1.8	3.7		2.7
46.0	5.3	3.6	2.5	5.8	3.8	2.6	5.6	3.9	2.6			1.6	3.5		2.5
48.0	4.9	3.4	2.4	5.4	3.6	2.5	5.3	3.7	2.5			3.2	2.6		2.3
50.0	4.6	3.2	2.3	5.1	3.4	2.4	5.0	3.6	2.4			3.0	2.5		2.1
54.0	4.1	2.9	2.1	4.5	3.1	2.2	4.4	3.2	2.3			2.6	2.2		1.7
58.0	3.6	2.6	2.0	3.6	2.8	2.0	3.6	2.9	2.1			2.3	1.9		
62.0	2.6	2.3	1.8	2.4	2.5	1.9	2.4	2.7	2.0			1.9	1.6		
66.0	1.6	2.1	1.7		2.3	1.8		2.4	1.8			1.6			
70.0		1.8	1.7		1.7	1.7		1.9	1.8						
θ(°)	39~ 83	44~ 84.5	51~ 84.5	47~ 83	49~ 84.5	56~ 84.5	51~ 83	54~ 84.5	60~ 84.5	65~ 83	60~ 84.5	70~ 84.5	80~ 83	70~ 84.5	80~ 84.5
標準フック	12.2t														
フック重量	440kg														
標準巻掛本数	1														

カウンタウエイト 78t、アウトリガ張出幅 8.0m

PS+ブーム+2.0m+47.5m油圧チルトジブ

単位:t

ブーム長さ(m) 作業半径 (m)	40.4		45.4		50.5	
	オフセット		オフセット		オフセット	
	0°	20°	0°	20°	0°	20°
16.0	6.7					
18.0	6.7		5.6			
20.0	6.7		5.6		3.3	
22.0	6.7		5.6		3.3	
24.0	6.7		5.6		3.3	
26.0	6.7		5.6		3.3	
28.0	6.7		5.6		3.3	
30.0	6.7		5.6		3.3	
32.0	6.7		5.6		3.3	
34.0	6.4	3.7	5.6		3.3	
36.0	5.9	3.5	5.6	3.6	3.3	
38.0	5.4	3.2	5.6	3.4	3.3	3.5
40.0	5.0	3.0	5.4	3.1	3.3	3.3
42.0	4.6	2.8	5.0	2.9	3.3	3.1
44.0	4.3	2.6	4.7	2.7	3.3	2.9
46.0	4.0	2.4	4.3	2.6	3.3	2.7
48.0	3.7	2.3	4.0	2.4	3.3	2.5
50.0	3.4	2.1	3.7	2.2	3.3	2.4
54.0	2.9	1.8	3.2	1.9	3.3	2.1
58.0	2.5	1.6	2.8	1.7	2.9	1.8
62.0	2.1		2.4	1.5	2.4	1.6
66.0	1.6					
θ(°)	44~ 84.5	62~ 84.5	51~ 84.5	62~ 84.5	54~ 84.5	65~ 84.5
標準フック	12.2t					
フック重量	440kg					
標準巻掛本数	1					

PS+油圧チルトジブ

カウンタウエイト 78t、アウトリガ張出幅 6.8m

PS+ブーム+2.0m+3.5m油圧チルトジブ

単位:t

ブーム長さ(m) 作業半径 (m)	40.4			45.4			50.5			55.6			60.0		
	オフセット			オフセット			オフセット			オフセット			オフセット		
	0°	20°	40°	0°	20°	40°	0°	20°	40°	0°	20°	40°	0°	20°	40°
8.0	58.6														
9.0	58.6	58.6		52.9											
10.0	58.6	58.6	53.9	52.0	48.4		34.9								
11.0	58.6	57.7	52.9	50.7	47.2	45.0	33.7	30.3		28.3					
12.0	58.6	56.5	51.9	49.5	46.2	44.1	32.6	29.4	27.4	27.3	25.1		26.0		
14.0	54.1	54.2	50.2	47.3	44.4	42.5	30.6	27.8	26.1	25.5	23.6	22.4	24.3	22.5	21.4
16.0	43.5	44.4	45.1	44.0	42.8	41.1	28.9	26.4	24.9	23.9	22.2	21.2	22.8	21.3	20.3
18.0	35.8	36.6	37.1	36.3	37.0	37.6	27.4	25.2	23.9	22.5	21.1	20.1	21.5	20.2	19.3
20.0	30.0	30.6	31.1	30.4	31.1	31.5	26.1	24.1	22.9	21.3	20.0	19.2	20.4	19.2	18.4
22.0	25.4	25.9	26.3	25.9	26.4	26.8	24.9	23.1	22.1	20.2	19.1	18.4	19.4	18.3	17.6
24.0	21.7	22.2	22.5	22.2	22.6	22.9	22.9	22.3	21.4	19.3	18.2	17.6	18.5	17.5	16.9
26.0	18.7	19.1	19.3	19.1	19.5	19.8	19.8	20.2	20.5	18.4	17.5	16.9	17.6	16.8	16.2
28.0	16.1	16.5	16.6	16.6	16.9	17.1	17.3	17.6	17.9	17.6	16.8	16.3	16.8	16.1	15.6
30.0	14.0	14.3	14.4	14.4	14.7	14.9	15.1	15.4	15.6	15.7	16.0	15.7	15.6	15.2	14.9
32.0	12.0	12.3	12.4	12.5	12.8	13.0	13.2	13.5	13.7	13.8	14.1	14.3	14.0	14.1	13.9
34.0	10.2	10.4	10.5	10.7	11.0	11.2	11.6	11.9	12.0	12.2	12.5	12.6	12.4	12.6	12.8
36.0	8.6	8.8		9.1	9.4	9.5	10.0	10.3	10.4	10.7	11.0	11.1	10.9	11.2	11.3
38.0	7.1	7.3		7.7	7.9	8.0	8.6	8.8	8.9	9.3	9.6	9.7	9.4	9.7	9.9
40.0	5.9	6.0		6.4	6.6		7.3	7.5	7.6	8.0	8.3	8.4	8.2	8.4	8.5
42.0	4.7			5.3	5.4		6.1	6.3	6.4	6.9	7.1	7.2	7.0	7.2	7.3
44.0	3.7			4.3	4.4		5.1	5.3		5.8	6.0	6.1	6.0	6.2	6.2
46.0				3.4	3.4		4.2	4.3		4.9	5.1	5.1	5.0	5.2	5.3
48.0				2.5			3.3	3.4		4.1	4.2		4.2	4.3	4.4
50.0							2.6	2.6		3.3	3.4		3.4	3.5	
54.0										1.9	2.0		2.0	2.1	
θ(°)	0~84	27~84	43~84	13~84	23~84.5	42~84.5	24~84.5	25~84.5	42~84.5	26~84.5	27~84.5	42~84.5	34~84.5	35~84.5	45~84.5
標準フック	80t						35t								
フック重量	1550kg						950kg								
標準巻掛本数	5						3								

カウンタウエイト 78t、アウトリガ張出幅 6.8m

PS+ブーム+2.0m+11.5m油圧チルトジブ

単位:t

ブーム長さ(m) 作業半径 (m)	40.4			45.4			50.5			55.6			60.0		
	オフセット			オフセット			オフセット			オフセット			オフセット		
	0°	20°	40°	0°	20°	40°	0°	20°	40°	0°	20°	40°	0°	20°	40°
10.0	45.4														
11.0	45.4			36.6											
12.0	44.8			36.6			27.9								
14.0	42.2	32.1		36.6	30.8		25.8			22.3			19.5		
16.0	39.8	30.6	24.5	36.6	29.6		24.0	19.0		20.7	17.0		19.5		
18.0	36.8	29.3	23.9	36.1	28.4	24.2	22.5	18.0	15.5	19.3	16.0		18.4	15.4	
20.0	31.0	28.1	23.3	31.3	27.4	23.5	21.1	17.1	14.9	18.1	15.2	13.5	17.3	14.6	
22.0	26.4	27.1	22.8	26.7	26.4	22.8	19.9	16.4	14.3	17.0	14.4	12.9	16.3	13.9	12.4
24.0	22.7	24.4	22.3	23.0	24.7	22.3	18.8	15.7	13.8	16.1	13.7	12.4	15.4	13.2	11.9
26.0	19.7	21.2	21.9	20.0	21.5	21.8	17.9	15.0	13.4	15.2	13.1	11.9	14.6	12.6	11.4
28.0	17.1	18.5	19.5	17.4	18.8	19.9	17.1	14.4	12.9	14.4	12.6	11.4	13.9	12.1	11.0
30.0	15.0	16.2	17.1	15.3	16.5	17.4	15.7	13.9	12.5	13.7	12.0	11.0	13.1	11.6	10.6
32.0	13.1	14.2	15.0	13.4	14.5	15.3	13.8	13.4	12.2	13.1	11.6	10.6	12.1	11.1	10.3
34.0	11.4	12.4	13.1	11.8	12.8	13.5	12.2	13.0	11.9	12.5	11.1	10.3	11.2	10.5	9.9
36.0	9.8	10.9	11.5	10.2	11.3	11.9	10.7	11.7	11.6	11.2	10.7	10.0	10.4	9.8	9.5
38.0	8.4	9.4	10.0	8.8	9.8	10.5	9.3	10.3	10.9	9.8	10.3	9.7	9.7	9.2	8.9
40.0	7.2	8.0	8.5	7.5	8.4	9.0	8.0	8.9	9.6	8.5	9.5	9.4	8.4	8.6	8.4
42.0	6.0	6.8	7.1	6.4	7.2	7.7	6.8	7.7	8.3	7.4	8.3	8.9	7.3	8.1	7.9
44.0	5.0	5.6		5.4	6.1	6.5	5.8	6.6	7.1	6.3	7.2	7.7	6.2	7.1	7.4
46.0	4.1	4.6		4.4	5.1	5.4	4.9	5.6	6.0	5.4	6.2	6.6	5.3	6.1	6.6
48.0	3.3	3.7		3.6	4.1		4.1	4.7	5.0	4.6	5.3	5.7	4.5	5.2	5.7
50.0	2.5			2.8	3.3		3.3	3.9	4.1	3.8	4.4	4.8	3.7	4.4	4.8
54.0							1.9	2.4		2.4	2.9	3.2	2.3	2.9	3.2
58.0											1.6				1.6
θ(°)	17~83	28~84.5	44~84.5	30~83	34~84.5	44~84.5	31~83	35~84.5	43~84.5	38~83	36~84.5	43~84.5	43~83	41~84.5	48~84.5
標準フック	80t						35t								
フック重量	1550kg						950kg								
標準巻掛本数	4						3								

カウンタウエイト 78t、アウトリガ張出幅 6.8m

PS+ブーム+2.0m+17.5m油圧チルトジブ

単位:t

ブーム長さ(m) 作業半径 (m)	40.4			45.4			50.5			55.6			60.0					
	オフセット			オフセット			オフセット			オフセット			オフセット					
	0°	20°	40°	0°	20°	40°	0°	20°	40°	0°	20°	40°	0°	20°	40°			
11.0	32.6																	
12.0	32.6			28.2														
14.0	32.6			28.2				21.7										
16.0	31.2	21.3		28.2				21.0			16.9			14.4				
18.0	29.4	20.2		28.1	20.7			19.6	14.9		16.9			14.0				
20.0	27.9	19.2		26.9	19.8			18.3	14.1		15.9	12.7		13.6				
22.0	26.5	18.3	14.0	25.6	18.9			17.2	13.4		14.9	12.1		13.1	11.6			
24.0	23.5	17.5	13.6	23.5	18.0	13.8		16.2	12.8	11.0	14.0	11.5		12.7	11.1			
26.0	20.4	16.7	13.3	20.5	17.3	13.5	15.3	12.3	10.6	13.2	10.9	9.6	9.6	12.1	10.6	9.3		
28.0	17.8	16.1	12.9	17.9	16.6	13.1	14.5	11.8	10.2	12.5	10.4	9.2	9.2	11.6	10.1	8.9		
30.0	15.7	15.4	12.7	15.7	16.0	12.9	13.8	11.3	9.9	11.9	10.0	8.9	8.9	11.1	9.7	8.6		
32.0	13.8	14.9	12.4	13.9	15.5	12.6	13.2	10.9	9.6	11.3	9.6	8.6	8.6	10.6	9.3	8.3		
34.0	12.2	13.6	12.2	12.2	13.7	12.4	12.6	10.5	9.3	10.8	9.2	8.3	8.3	9.8	8.9	8.0		
36.0	10.7	12.1	12.0	10.7	12.2	12.2	11.2	10.1	9.1	10.3	8.8	8.0	8.0	9.1	8.4	7.6		
38.0	9.2	10.7	11.6	9.3	10.8	11.8	9.8	9.8	8.8	9.8	8.5	7.8	7.8	8.4	7.8	7.3		
40.0	8.0	9.3	10.2	8.0	9.5	10.4	8.5	9.5	8.6	8.8	8.2	7.5	7.5	7.8	7.3	7.0		
42.0	6.8	8.1	8.9	6.9	8.2	9.2	7.4	8.7	8.4	7.6	7.9	7.3	7.3	6.9	6.7	6.7		
44.0	5.8	6.9	7.6	5.9	7.1	7.9	6.3	7.6	8.2	6.6	7.7	7.1	7.1	6.4	6.4	6.3		
46.0	4.9	5.8	6.4	4.9	6.0	6.8	5.4	6.6	7.4	5.7	6.9	6.9	6.9	5.5	6.0	5.9		
48.0	4.0	4.9	5.3	4.1	5.1	5.7	4.5	5.6	6.3	4.8	5.9	5.9	5.9	4.6	5.6	5.6		
50.0	3.2	4.0		3.3	4.2	4.7	3.8	4.7	5.3	4.0	5.1	5.7	5.7	3.9	4.9	5.3		
54.0		2.4		2.0	2.7		2.4	3.2	3.6	2.7	3.5	4.1	4.1	2.5	3.4	4.0		
58.0								1.8		1.5	2.2	2.6	2.6		2.1	2.6		
θ(°)	32~ 83	28~ 84.5	44~ 84.5	33~ 83	38~ 84.5	48~ 84.5	40~ 83	38~ 84.5	47~ 84.5	40~ 83	44~ 84.5	47~ 84.5	48~ 83	49~ 84.5	52~ 84.5			
標準フック	35t						35t											
フック重量	950kg						950kg											
標準巻掛本数	3						2											

カウンタウエイト 78t、アウトリガ張出幅 6.8m

PS+ブーム+2.0m+23.5m油圧チルトジブ

単位:t

ブーム長さ(m) 作業半径 (m)	40.4			45.4			50.5			55.6			60.0					
	オフセット			オフセット			オフセット			オフセット			オフセット					
	0°	20°	40°	0°	20°	40°	0°	20°	40°	0°	20°	40°	0°	20°	40°			
12.0	24.7																	
14.0	24.7			21.4				16.6										
16.0	24.7			21.4				16.6			12.7							
18.0	24.3			21.4				16.6			12.7			10.4				
20.0	23.0	14.4		21.4				16.1			12.7			10.0				
22.0	21.7	13.6		21.1	14.0			15.1	11.3		12.7			9.6				
24.0	20.1	12.9		20.1	13.3			14.1	10.8		12.4	9.8		9.2				
26.0	18.6	12.3	9.3	19.2	12.7			13.3	10.3		11.7	9.4		8.8	9.0			
28.0	17.3	11.7	9.0	18.4	12.1	9.1		12.6	9.9		11.0	8.9		8.3	8.6			
30.0	16.1	11.2	8.7	16.2	11.6	8.9		12.0	9.5	8.1	10.4	8.5	7.4	7.9	8.2			
32.0	14.3	10.7	8.5	14.3	11.2	8.6	11.4	9.1	7.8	9.9	8.1	7.1	7.4	7.7	6.5			
34.0	12.7	10.3	8.3	12.7	10.7	8.4	10.8	8.7	7.6	9.4	7.8	6.9	7.0	7.3	6.2			
36.0	11.3	9.9	8.1	11.3	10.3	8.2	10.3	8.4	7.3	8.9	7.5	6.6	6.6	6.8	5.9			
38.0	9.9	9.6	7.9	9.9	10.0	8.1	9.9	8.1	7.1	8.5	7.2	6.4	6.1	6.5	5.7			
40.0	8.6	9.2	7.7	8.6	9.6	7.9	8.8	7.8	6.9	8.1	6.9	6.2	5.8	6.1	5.4			
42.0	7.4	8.9	7.6	7.4	9.3	7.7	7.7	7.6	6.7	7.8	6.7	6.0	5.4	5.8	5.1			
44.0	6.4	8.0	7.5	6.4	8.1	7.6	6.6	7.3	6.6	6.8	6.4	5.8	5.0	5.5	4.9			
46.0	5.5	6.9	7.4	5.5	7.0	7.5	5.7	7.1	6.4	5.9	6.2	5.6	4.7	5.1	4.7			
48.0	4.6	5.9	6.9	4.6	6.0	7.1	4.8	6.3	6.3	5.0	6.0	5.5	4.4	4.8	4.5			
50.0	3.8	5.0	5.8	3.8	5.1	6.1	4.0	5.4	6.1	4.2	5.6	5.3	4.0	4.4	4.3			
54.0	2.4	3.4	3.9	2.4	3.5	4.2	2.7	3.8	4.6	2.8	4.0	4.9	2.6	3.9	3.9			
58.0		1.9			2.1	2.6	1.5	2.4	3.1	1.7	2.7	3.4			3.4			
62.0									1.7		1.5	2.1			2.0			
θ(°)	34~ 83	33~ 84.5	45~ 84.5	41~ 83	42~ 84.5	45~ 84.5	41~ 83	47~ 84.5	45~ 84.5	45~ 83	47~ 84.5	51~ 84.5	52~ 83	55~ 84.5	55~ 84.5			
標準フック	35t						35t											
フック重量	950kg						950kg											
標準巻掛本数	3						2											

PS+油圧チルトジブ

カウンタウエイト 78t、アウトリガ張出幅 6.8m

PS+ブーム+2.0m+29.5m油圧チルトジブ

単位:t

ブーム長さ(m) 作業半径 (m)	40.4			45.4			50.5			55.6			60.0		
	オフセット			オフセット			オフセット			オフセット			オフセット		
	0°	20°	40°	0°	20°	40°	0°	20°	40°	0°	20°	40°	0°	20°	40°
14.0	18.7			16.1											
16.0	18.7			16.1			12.4								
18.0	18.7			16.1			12.4						7.0		
20.0	18.7			16.1			12.4			8.7			6.7		
22.0	17.8			16.1			12.4			8.7			6.3		
24.0	16.5	10.2		16.1	10.5		12.4			8.7			6.0		
26.0	15.2	9.6		15.7	9.9		11.8	8.9		8.6			5.6		
28.0	14.1	9.1		15.1	9.4		11.1	8.5		8.4	8.0		5.3		
30.0	13.1	8.7		14.1	9.0		10.5	8.1		8.3	7.6		4.9	6.7	
32.0	12.2	8.3	6.2	13.1	8.6	6.3	10.0	7.8		8.1	7.3		4.6	6.3	
34.0	11.4	7.9	6.0	12.3	8.2	6.1	9.5	7.5	6.2	7.9	6.9		4.2	5.9	
36.0	10.7	7.6	5.9	11.5	7.9	6.0	9.0	7.2	6.0	7.7	6.6	5.8	3.9	5.5	
38.0	10.0	7.2	5.7	10.1	7.5	5.8	8.6	6.9	5.9	7.5	6.4	5.6	3.5	5.2	4.4
40.0	8.9	6.9	5.5	8.8	7.2	5.6	8.2	6.6	5.7	7.3	6.1	5.4	3.2	4.9	4.2
42.0	7.8	6.7	5.4	7.7	7.0	5.5	7.8	6.4	5.6	7.0	5.8	5.2	2.9	4.6	4.0
44.0	6.7	6.4	5.3	6.6	6.7	5.4	6.8	6.2	5.4	6.7	5.6	5.0	2.6	4.3	3.8
46.0	5.8	6.2	5.1	5.7	6.5	5.2	5.8	6.0	5.2	6.2	5.4	4.8	2.3	4.1	3.6
48.0	4.9	6.0	5.0	4.8	6.3	5.1	5.0	5.8	5.1	5.3	5.2	4.6	2.1	3.9	3.4
50.0	4.1	5.7	5.0	4.0	5.7	5.0	4.2	5.6	5.0	4.5	5.0	4.4	1.8	3.6	3.3
54.0	2.8	4.1	4.8	2.7	4.1	4.9	2.8	4.3	4.7	3.1	4.5	4.0		3.2	3.0
58.0	1.6	2.7	3.4	1.5	2.7	3.6	1.6	2.9	3.9	1.9	3.3	3.7		2.7	2.7
62.0					1.5	2.1		1.7	2.5		2.1	3.0			2.4
θ(°)	36~ 83	44~ 84.5	49~ 84.5	42~ 83	45~ 84.5	49~ 84.5	46~ 83	49~ 84.5	54~ 84.5	50~ 83	54~ 84.5	59~ 84.5	59~ 83	60~ 84.5	61~ 84.5
標準フック	35t						12.2t								
フック重量	950kg						440kg								
標準巻掛本数	2						1								

カウンタウエイト 78t、アウトリガ張出幅 6.8m

PS+ブーム+2.0m+35.5m油圧チルトジブ

単位:t

ブーム長さ(m) 作業半径 (m)	40.4			45.4			50.5			55.6			60.0		
	オフセット			オフセット			オフセット			オフセット			オフセット		
	0°	20°	40°	0°	20°	40°	0°	20°	40°	0°	20°	40°	0°	20°	40°
14.0	14.1														
16.0	14.1			12.2											
18.0	14.1			12.2			8.8								
20.0	14.1			12.2			8.8			6.1			4.4		
22.0	14.1			12.2			8.8			6.1			4.2		
24.0	13.9			12.2			8.8			6.1			3.8		
26.0	13.0	7.9		12.2			8.8			6.0			3.5		
28.0	12.0	7.5		12.2	7.7		8.8			5.8			3.2		
30.0	11.1	7.1		11.8	7.3		8.8	7.4		5.7			2.9		
32.0	10.3	6.7		11.1	6.9		8.8	7.1		5.5	6.5		2.6	5.4	
34.0	9.6	6.4		10.3	6.6		8.8	6.8		5.3	6.2		2.2	5.0	
36.0	8.9	6.1	4.5	9.7	6.3		8.3	6.5		5.2	5.9		1.9	4.7	
38.0	8.4	5.8	4.3	9.0	6.0	4.4	7.9	6.2		5.0	5.6		1.6	4.4	
40.0	7.9	5.5	4.2	8.5	5.7	4.2	7.5	6.0	4.5	4.8	5.4			4.1	
42.0	7.4	5.3	4.0	8.0	5.5	4.1	7.2	5.7	4.4	4.6	5.1	4.4		3.9	3.3
44.0	7.0	5.0	3.9	7.0	5.3	4.0	6.9	5.5	4.3	4.3	4.9	4.2		3.6	3.1
46.0	6.2	4.8	3.8	6.0	5.0	3.9	6.4	5.3	4.1	4.1	4.6	4.0		3.4	2.9
48.0	5.3	4.6	3.7	5.2	4.8	3.7	5.5	5.1	4.0	3.9	4.3	3.8		3.2	2.7
50.0	4.5	4.4	3.6	4.4	4.7	3.7	4.7	4.9	3.9	3.7	4.1	3.6		3.0	2.6
54.0	3.2	4.1	3.4	3.0	4.3	3.5	3.3	4.5	3.7	3.2	3.7	3.2		2.6	2.3
58.0	2.0	3.4	3.3	1.8	3.4	3.3	2.1	3.7	3.6	2.2	3.3	2.9		2.3	2.0
62.0		2.2	3.0		2.1	3.2		2.5	3.4		2.6	2.6			1.8
66.0			1.6			1.8			2.3			2.4			
θ(°)	42~ 83	47~ 84.5	46~ 84.5	47~ 83	52~ 84.5	53~ 84.5	51~ 83	56~ 84.5	58~ 84.5	54~ 83	59~ 84.5	61~ 84.5	61~ 83	64~ 84.5	67~ 84.5
標準フック	35t						12.2t								
フック重量	950kg						440kg								
標準巻掛本数	2						1								

カウンタウエイト 78t、アウトリガ張出幅 6.8m
PS+ブーム+2.0m+41.5m油圧チルトジブ

単位:t

ブーム長さ(m) 作業半径 (m)	40.4			45.4			50.5			55.6			60.0		
	オフセット			オフセット			オフセット			オフセット			オフセット		
	0°	20°	40°	0°	20°	40°	0°	20°	40°	0°	20°	40°	0°	20°	40°
16.0	10.1			8.6											
18.0	10.1			8.6			6.0								
20.0	10.1			8.6			6.0				3.5				
22.0	10.1			8.6			6.0				3.5			1.9	
24.0	10.1			8.6			6.0				3.5			1.6	
26.0	10.1			8.6			6.0				3.4				
28.0	10.1			8.6			6.0				3.2				
30.0	9.5	5.8		8.6			6.0				3.1				
32.0	8.8	5.4		8.6	5.6		6.0				2.9				
34.0	8.2	5.1		8.6	5.3		6.0	5.4			2.8				
36.0	7.6	4.8		8.2	5.0		6.0	5.1			2.6	4.8			3.1
38.0	7.0	4.5		7.6	4.7		6.0	4.9			2.4	4.6			3.1
40.0	6.5	4.2		7.1	4.4		6.0	4.6			2.2	4.3			3.1
42.0	6.1	4.0	2.8	6.6	4.2		6.0	4.4			2.0	4.0			2.9
44.0	5.7	3.8	2.6	6.2	4.0	2.7	5.9	4.1			1.8	3.7			2.7
46.0	5.3	3.6	2.5	5.8	3.8	2.6	5.6	3.9	2.6		1.6	3.5			2.5
48.0	4.9	3.4	2.4	5.3	3.6	2.5	5.3	3.7	2.5			3.2	2.6		2.3
50.0	4.6	3.2	2.3	4.5	3.4	2.4	4.5	3.6	2.4			3.0	2.5		2.1
54.0	3.3	2.9	2.1	3.1	3.1	2.2	3.1	3.2	2.3			2.6	2.2		1.7
58.0	2.1	2.6	2.0	1.9	2.8	2.0		2.9	2.1			2.3	1.9		
62.0		2.3	1.8		2.5	1.9		2.6	2.0			1.9	1.6		
66.0		1.5	1.7			1.8			1.8						
θ(°)	47~ 83	49~ 84.5	56~ 84.5	51~ 83	57~ 84.5	61~ 84.5	57~ 83	61~ 84.5	64~ 84.5	65~ 83	63~ 84.5	70~ 84.5	80~ 83	70~ 84.5	80~ 84.5
標準フック	12.2t														
フック重量	440kg														
標準巻掛本数	1														

PS+油圧チルトジブ

カウンタウエイト 58t、アウトリガ張出幅 8.5m

PS+ブーム+2.0m+3.5m油圧チルトジブ

単位:t

ブーム長さ(m) 作業半径 (m)	40.4			45.4			50.5			55.6			60.0		
	オフセット			オフセット			オフセット			オフセット			オフセット		
	0°	20°	40°	0°	20°	40°	0°	20°	40°	0°	20°	40°	0°	20°	40°
8.0	58.6														
9.0	58.6	58.6		52.9											
10.0	58.6	58.6	53.9	52.0	48.4		34.9								
11.0	58.6	57.7	52.9	50.7	47.2	45.0	33.7	30.3		28.3					
12.0	58.6	56.5	51.9	49.5	46.2	44.1	32.6	29.4	27.4	27.3	25.1		26.0		
14.0	53.9	54.2	50.2	47.3	44.4	42.5	30.6	27.8	26.1	25.5	23.6	22.4	24.3	22.5	21.4
16.0	43.1	44.0	44.7	43.6	42.8	41.1	28.9	26.4	24.9	23.9	22.2	21.2	22.8	21.3	20.3
18.0	35.3	36.1	36.6	35.8	36.6	37.1	27.4	25.2	23.9	22.5	21.1	20.1	21.5	20.2	19.3
20.0	29.5	30.1	30.5	29.9	30.6	31.0	26.1	24.1	22.9	21.3	20.0	19.2	20.4	19.2	18.4
22.0	24.9	25.4	25.8	25.3	25.9	26.2	24.9	23.1	22.1	20.2	19.1	18.4	19.4	18.3	17.6
24.0	21.1	21.6	21.9	21.6	22.1	22.4	22.3	22.3	21.4	19.3	18.2	17.6	18.5	17.5	16.9
26.0	18.0	18.4	18.6	18.5	18.9	19.1	19.2	19.6	19.9	18.4	17.5	16.9	17.6	16.8	16.2
28.0	15.4	15.8	16.0	15.9	16.2	16.5	16.6	17.0	17.2	17.3	16.8	16.3	16.8	16.1	15.6
30.0	13.2	13.5	13.7	13.7	14.0	14.2	14.4	14.7	14.9	15.1	15.4	15.6	15.2	15.2	14.9
32.0	11.3	11.6	11.7	11.8	12.1	12.2	12.5	12.8	13.0	13.2	13.5	13.6	13.3	13.6	13.8
34.0	9.4	9.7	9.8	10.0	10.3	10.4	10.9	11.2	11.3	11.5	11.8	12.0	11.7	12.0	12.1
36.0	7.8	8.0		8.4	8.7	8.7	9.3	9.6	9.7	10.0	10.3	10.5	10.2	10.5	10.6
38.0	6.4	6.6		7.0	7.2	7.3	7.9	8.1	8.2	8.6	8.9	9.0	8.8	9.0	9.2
40.0	5.1	5.2		5.7	5.9		6.6	6.8	6.9	7.3	7.6	7.7	7.5	7.7	7.9
42.0	4.0			4.6	4.7		5.5	5.6	5.7	6.2	6.4	6.5	6.3	6.6	6.7
44.0	3.0			3.6	3.7		4.5	4.6		5.2	5.4	5.4	5.3	5.5	5.6
46.0				2.7	2.8		3.5	3.7		4.3	4.4	4.5	4.4	4.6	4.6
48.0							2.7	2.8		3.4	3.6		3.5	3.7	3.7
50.0							2.0	2.0		2.7	2.8		2.8	2.9	
54.0														1.5	
θ(°)	0~	27~	43~	22~	23~	42~	24~	25~	42~	35~	35~	42~	41~	35~	45~
	84.5	84.5	84.5	84.5	84.5	84.5	84.5	84.5	84.5	84.5	84.5	84.5	84.5	84.5	84.5
標準フック	80t						35t								
フック重量	1550kg						950kg								
標準巻掛本数	5						3								

カウンタウエイト 58t、アウトリガ張出幅 8.5m

PS+ブーム+2.0m+11.5m油圧チルトジブ

単位:t

ブーム長さ(m) 作業半径 (m)	40.4			45.4			50.5			55.6			60.0		
	オフセット			オフセット			オフセット			オフセット			オフセット		
	0°	20°	40°	0°	20°	40°	0°	20°	40°	0°	20°	40°	0°	20°	40°
10.0	45.4														
11.0	45.4			36.6											
12.0	44.8			36.6			27.9								
14.0	42.2	32.1		36.6	30.8		25.8			22.3			19.5		
16.0	39.8	30.6	24.5	36.6	29.6		24.0	19.0		20.7	17.0		19.5		
18.0	36.4	29.3	23.9	36.1	28.4	24.2	22.5	18.0	15.5	19.3	16.0		18.4	15.4	
20.0	30.5	28.1	23.3	30.8	27.4	23.5	21.1	17.1	14.9	18.1	15.2	13.5	17.3	14.6	
22.0	25.9	27.1	22.8	26.2	26.4	22.8	19.9	16.4	14.3	17.0	14.4	12.9	16.3	13.9	12.4
24.0	22.2	23.9	22.3	22.5	24.2	22.3	18.8	15.7	13.8	16.1	13.7	12.4	15.4	13.2	11.9
26.0	19.1	20.6	21.9	19.4	21.0	21.8	17.9	15.0	13.4	15.2	13.1	11.9	14.6	12.6	11.4
28.0	16.5	17.9	18.9	16.8	18.2	19.3	17.1	14.4	12.9	14.4	12.6	11.4	13.9	12.1	11.0
30.0	14.3	15.5	16.5	14.6	15.9	16.9	15.0	13.9	12.5	13.7	12.0	11.0	13.1	11.6	10.6
32.0	12.4	13.5	14.3	12.7	13.9	14.7	13.1	13.4	12.2	13.1	11.6	10.6	12.1	11.1	10.3
34.0	10.8	11.8	12.5	11.1	12.2	12.9	11.5	12.5	11.9	12.0	11.1	10.3	11.2	10.5	9.9
36.0	9.2	10.3	10.9	9.5	10.6	11.3	10.0	11.0	11.6	10.6	10.7	10.0	10.4	9.8	9.5
38.0	7.7	8.7	9.4	8.1	9.2	9.9	8.6	9.7	10.3	9.2	10.2	9.7	9.0	9.2	8.9
40.0	6.5	7.4	7.9	6.9	7.8	8.4	7.3	8.3	9.0	7.9	8.9	8.4	7.8	8.6	8.4
42.0	5.4	6.1	6.5	5.7	6.6	7.1	6.2	7.1	7.7	6.8	7.7	7.3	6.6	7.6	7.9
44.0	4.4	5.0		4.7	5.5	5.9	5.2	6.0	6.5	5.7	6.6	6.1	5.6	6.5	7.1
46.0	3.5	4.0		3.8	4.5	4.8	4.3	5.0	5.4	4.8	5.6	5.1	4.7	5.5	6.1
48.0	2.7	3.1		3.0	3.5		3.5	4.1	4.5	4.0	4.7	4.1	3.9	4.6	5.1
50.0					2.7		2.7	3.3	3.5	3.2	3.8	3.2	3.1	3.8	4.2
54.0								1.8		1.9	2.4	2.6	1.8	2.3	2.6
θ(°)	24~	28~	44~	34~	34~	44~	38~	35~	43~	38~	42~	43~	43~	46~	48~
	83	84.5	84.5	83	84.5	84.5	83	84.5	84.5	83	84.5	84.5	83	84.5	84.5
標準フック	80t						35t								
フック重量	1550kg						950kg								
標準巻掛本数	4						3								

カウンタウエイト 58t、アウトリガ張出幅 8.5m

PS+ブーム+2.0m+17.5m油圧チルトジブ

単位:t

ブーム長さ(m) 作業半径 (m)	40.4			45.4			50.5			55.6			60.0		
	オフセット			オフセット			オフセット			オフセット			オフセット		
	0°	20°	40°	0°	20°	40°	0°	20°	40°	0°	20°	40°	0°	20°	40°
11.0	32.6														
12.0	32.6			28.2											
14.0	32.6			28.2			21.7								
16.0	31.2	21.3		28.2			21.0			16.9			14.4		
18.0	29.4	20.2		28.1	20.7		19.6	14.9		16.9			14.0		
20.0	27.9	19.2		26.9	19.8		18.3	14.1		15.9	12.7		13.6		
22.0	26.5	18.3	14.0	25.6	18.9		17.2	13.4		14.9	12.1		13.1	11.6	
24.0	23.0	17.5	13.6	23.0	18.0	13.8	16.2	12.8	11.0	14.0	11.5		12.7	11.1	
26.0	19.9	16.7	13.3	19.9	17.3	13.5	15.3	12.3	10.6	13.2	10.9	9.6	12.1	10.6	9.3
28.0	17.2	16.1	12.9	17.3	16.6	13.1	14.5	11.8	10.2	12.5	10.4	9.2	11.6	10.1	8.9
30.0	15.0	15.4	12.7	15.1	16.0	12.9	13.8	11.3	9.9	11.9	10.0	8.9	11.1	9.7	8.6
32.0	13.2	14.8	12.4	13.2	14.9	12.6	13.2	10.9	9.6	11.3	9.6	8.6	10.6	9.3	8.3
34.0	11.5	13.0	12.2	11.6	13.2	12.4	12.0	10.5	9.3	10.8	9.2	8.3	9.8	8.9	8.0
36.0	10.0	11.5	12.0	10.1	11.6	12.2	10.6	10.1	9.1	10.3	8.8	8.0	9.1	8.4	7.6
38.0	8.6	10.1	11.0	8.7	10.2	11.2	9.2	9.8	8.8	9.5	8.5	7.8	8.4	7.8	7.3
40.0	7.3	8.7	9.7	7.4	8.9	9.9	7.9	9.4	8.6	8.2	8.2	7.5	7.8	7.3	7.0
42.0	6.2	7.5	8.4	6.3	7.7	8.6	6.8	8.2	8.4	7.0	7.9	7.3	6.9	6.9	6.7
44.0	5.2	6.3	7.1	5.3	6.5	7.4	5.7	7.0	7.9	6.0	7.3	7.1	5.8	6.4	6.3
46.0	4.3	5.3	5.9	4.3	5.5	6.2	4.8	6.0	6.8	5.1	6.3	6.9	4.9	6.0	5.9
48.0	3.4	4.3	4.8	3.5	4.5	5.2	4.0	5.0	5.8	4.2	5.4	6.2	4.1	5.3	5.6
50.0	2.7	3.4		2.8	3.7	4.2	3.2	4.2	4.8	3.5	4.5	5.2	3.3	4.4	5.2
54.0					2.1		1.8	2.6	3.1	2.1	3.0	3.5	2.0	2.9	3.5
58.0											1.7	2.1			2.1
θ(°)	32~83	38~84.5	44~84.5	39~83	38~84.5	48~84.5	40~83	44~84.5	47~84.5	45~83	44~84.5	47~84.5	48~83	53~84.5	52~84.5
標準フック	35t						35t								
フック重量	950kg						950kg								
標準巻掛本数	3						2								

カウンタウエイト 58t、アウトリガ張出幅 8.5m

PS+ブーム+2.0m+23.5m油圧チルトジブ

単位:t

ブーム長さ(m) 作業半径 (m)	40.4			45.4			50.5			55.6			60.0		
	オフセット			オフセット			オフセット			オフセット			オフセット		
	0°	20°	40°	0°	20°	40°	0°	20°	40°	0°	20°	40°	0°	20°	40°
12.0	24.7														
14.0	24.7			21.4			16.6								
16.0	24.7			21.4			16.6			12.7					
18.0	24.3			21.4			16.6			12.7			10.4		
20.0	23.0	14.4		21.4			16.1			12.7			10.0		
22.0	21.7	13.6		21.1	14.0		15.1	11.3		12.7			9.6		
24.0	20.1	12.9		20.1	13.3		14.1	10.8		12.4	9.8		9.2		
26.0	18.6	12.3	9.3	19.2	12.7		13.3	10.3		11.7	9.4		8.8	9.0	
28.0	17.3	11.7	9.0	17.9	12.1	9.1	12.6	9.9		11.0	8.9		8.3	8.6	
30.0	15.7	11.2	8.7	15.7	11.6	8.9	12.0	9.5	8.1	10.4	8.5	7.4	7.9	8.2	
32.0	13.8	10.7	8.5	13.7	11.2	8.6	11.4	9.1	7.8	9.9	8.1	7.1	7.4	7.7	6.5
34.0	12.1	10.3	8.3	12.1	10.7	8.4	10.8	8.7	7.6	9.4	7.8	6.9	7.0	7.3	6.2
36.0	10.7	9.9	8.1	10.7	10.3	8.2	10.3	8.4	7.3	8.9	7.5	6.6	6.6	6.8	5.9
38.0	9.3	9.6	7.9	9.3	10.0	8.1	9.5	8.1	7.1	8.5	7.2	6.4	6.1	6.5	5.7
40.0	8.0	9.2	7.7	8.0	9.6	7.9	8.2	7.8	6.9	8.1	6.9	6.2	5.8	6.1	5.4
42.0	6.9	8.6	7.6	6.8	8.7	7.7	7.1	7.6	6.7	7.3	6.7	6.0	5.4	5.8	5.1
44.0	5.8	7.4	7.5	5.8	7.5	7.6	6.0	7.3	6.6	6.2	6.4	5.8	5.0	5.5	4.9
46.0	4.9	6.4	7.4	4.9	6.5	7.5	5.1	6.7	6.4	5.3	6.2	5.6	4.7	5.1	4.7
48.0	4.0	5.4	6.3	4.0	5.5	6.6	4.3	5.8	6.3	4.4	6.0	5.5	4.2	4.8	4.5
50.0	3.3	4.5	5.3	3.3	4.6	5.5	3.5	4.9	5.9	3.7	5.1	5.3	3.5	4.4	4.3
54.0	1.9	2.9	3.4	1.9	3.0	3.7	2.1	3.3	4.1	2.3	3.5	4.4		3.4	3.9
58.0					1.6	2.1		2.0	2.6		2.2	2.9		2.1	2.9
θ(°)	34~83	41~84.5	45~84.5	41~83	42~84.5	45~84.5	45~83	47~84.5	51~84.5	50~83	52~84.5	56~84.5	56~83	55~84.5	59~84.5
標準フック	35t						35t								
フック重量	950kg						950kg								
標準巻掛本数	3						2								

PS+油圧チルトジブ

カウンタウエイト 58t、アウトリガ張出幅 8.5m

PS+ブーム+2.0m+29.5m油圧チルトジブ

単位:t

ブーム長さ(m) 作業半径 (m)	40.4			45.4			50.5			55.6			60.0			
	オフセット			オフセット			オフセット			オフセット			オフセット			
	0°	20°	40°	0°	20°	40°	0°	20°	40°	0°	20°	40°	0°	20°	40°	
14.0	18.7			16.1												
16.0	18.7			16.1			12.4									
18.0	18.7			16.1			12.4							7.0		
20.0	18.7			16.1			12.4			8.7				6.7		
22.0	17.8			16.1			12.4			8.7				6.3		
24.0	16.5	10.2		16.1	10.5		12.4			8.7				6.0		
26.0	15.2	9.6		15.7	9.9		11.8	8.9		8.6				5.6		
28.0	14.1	9.1		15.1	9.4		11.1	8.5		8.4	8.0			5.3		
30.0	13.1	8.7		14.1	9.0		10.5	8.1		8.3	7.6			4.9	6.7	
32.0	12.2	8.3	6.2	13.1	8.6	6.3	10.0	7.8		8.1	7.3			4.6	6.3	
34.0	11.4	7.9	6.0	12.3	8.2	6.1	9.5	7.5	6.2	7.9	6.9			4.2	5.9	
36.0	10.7	7.6	5.9	10.9	7.9	6.0	9.0	7.2	6.0	7.7	6.6	5.8		3.9	5.5	
38.0	9.6	7.2	5.7	9.5	7.5	5.8	8.6	6.9	5.9	7.5	6.4	5.6		3.5	5.2	4.4
40.0	8.4	6.9	5.5	8.3	7.2	5.6	8.2	6.6	5.7	7.3	6.1	5.4		3.2	4.9	4.2
42.0	7.2	6.7	5.4	7.1	7.0	5.5	7.2	6.4	5.6	7.0	5.8	5.2		2.9	4.6	4.0
44.0	6.2	6.4	5.3	6.1	6.7	5.4	6.2	6.2	5.4	6.6	5.6	5.0		2.6	4.3	3.8
46.0	5.2	6.2	5.1	5.1	6.5	5.2	5.3	6.0	5.2	5.7	5.4	4.8		2.3	4.1	3.6
48.0	4.4	6.0	5.0	4.3	6.2	5.1	4.4	5.8	5.1	4.8	5.2	4.6		2.1	3.9	3.4
50.0	3.6	5.2	5.0	3.5	5.2	5.0	3.6	5.4	5.0	4.0	5.0	4.4		1.8	3.6	3.3
54.0	2.2	3.6	4.6	2.2	3.6	4.8	2.3	3.8	4.7	2.6	4.2	4.0			3.2	3.0
58.0		2.2	2.9		2.2	3.1		2.5	3.4		2.8	3.7			2.7	2.7
62.0						1.7			2.0						2.5	
θ(°)	41~ 83	44~ 84.5	49~ 84.5	46~ 83	50~ 84.5	49~ 84.5	50~ 83	54~ 84.5	54~ 84.5	54~ 83	57~ 84.5	59~ 84.5	59~ 83	60~ 84.5	65~ 84.5	
標準フック	35t											12.2t				
フック重量	950kg											440kg				
標準巻掛本数	2											1				

カウンタウエイト 58t、アウトリガ張出幅 8.5m

PS+ブーム+2.0m+35.5m油圧チルトジブ

単位:t

ブーム長さ(m) 作業半径 (m)	40.4			45.4			50.5			55.6			60.0			
	オフセット			オフセット			オフセット			オフセット			オフセット			
	0°	20°	40°	0°	20°	40°	0°	20°	40°	0°	20°	40°	0°	20°	40°	
14.0	14.1															
16.0	14.1			12.2												
18.0	14.1			12.2			8.8									
20.0	14.1			12.2			8.8			6.1				4.4		
22.0	14.1			12.2			8.8			6.1				4.2		
24.0	13.9			12.2			8.8			6.1				3.8		
26.0	13.0	7.9		12.2			8.8			6.0				3.5		
28.0	12.0	7.5		12.2	7.7		8.8			5.8				3.2		
30.0	11.1	7.1		11.8	7.3		8.8	7.4		5.7				2.9		
32.0	10.3	6.7		11.1	6.9		8.8	7.1		5.5	6.5			2.6	5.4	
34.0	9.6	6.4		10.3	6.6		8.8	6.8		5.3	6.2			2.2	5.0	
36.0	8.9	6.1	4.5	9.7	6.3		8.3	6.5		5.2	5.9			1.9	4.7	
38.0	8.4	5.8	4.3	9.0	6.0	4.4	7.9	6.2		5.0	5.6			1.6	4.4	
40.0	7.9	5.5	4.2	8.5	5.7	4.2	7.5	6.0	4.5	4.8	5.4				4.1	
42.0	7.4	5.3	4.0	7.5	5.5	4.1	7.2	5.7	4.4	4.6	5.1	4.4			3.9	3.3
44.0	6.6	5.0	3.9	6.4	5.3	4.0	6.8	5.5	4.3	4.3	4.9	4.2			3.6	3.1
46.0	5.7	4.8	3.8	5.5	5.0	3.9	5.8	5.3	4.1	4.1	4.6	4.0			3.4	2.9
48.0	4.8	4.6	3.7	4.7	4.8	3.7	5.0	5.1	4.0	3.9	4.3	3.8			3.2	2.7
50.0	4.0	4.4	3.6	3.9	4.7	3.7	4.2	4.9	3.9	3.7	4.1	3.6			3.0	2.6
54.0	2.7	4.1	3.4	2.5	4.3	3.5	2.8	4.5	3.7	2.9	3.7	3.2			2.6	2.3
58.0	1.5	3.0	3.3		2.9	3.3		3.3	3.6		3.3	2.9			2.3	2.0
62.0		1.7	2.6		1.7	2.8		2.1	3.2			2.6				1.8
θ(°)	42~ 83	47~ 84.5	53~ 84.5	50~ 83	52~ 84.5	58~ 84.5	54~ 83	56~ 84.5	62~ 84.5	57~ 83	62~ 84.5	65~ 84.5	70~ 83	64~ 84.5	67~ 84.5	
標準フック	35t											12.2t				
フック重量	950kg											440kg				
標準巻掛本数	2											1				

カウンタウエイト 58t、アウトリガ張出幅 8.5m
PS+ブーム+2.0m+41.5m油圧チルトジブ

単位:t

ブーム長さ(m) 作業半径 (m)	40.4			45.4			50.5			55.6			60.0		
	オフセット			オフセット			オフセット			オフセット			オフセット		
	0°	20°	40°	0°	20°	40°	0°	20°	40°	0°	20°	40°	0°	20°	40°
16.0	10.1			8.6											
18.0	10.1			8.6			6.0								
20.0	10.1			8.6			6.0				3.5				
22.0	10.1			8.6			6.0				3.5			1.9	
24.0	10.1			8.6			6.0				3.5			1.6	
26.0	10.1			8.6			6.0				3.4				
28.0	10.1			8.6			6.0				3.2				
30.0	9.5	5.8		8.6			6.0				3.1				
32.0	8.8	5.4		8.6	5.6		6.0				2.9				
34.0	8.2	5.1		8.6	5.3		6.0	5.4			2.8				
36.0	7.6	4.8		8.2	5.0		6.0	5.1			2.6	4.8			3.1
38.0	7.0	4.5		7.6	4.7		6.0	4.9			2.4	4.6			3.1
40.0	6.5	4.2		7.1	4.4		6.0	4.6			2.2	4.3			3.1
42.0	6.1	4.0	2.8	6.6	4.2		6.0	4.4			2.0	4.0			2.9
44.0	5.7	3.8	2.6	6.2	4.0	2.7	5.9	4.1			1.8	3.7			2.7
46.0	5.3	3.6	2.5	5.7	3.8	2.6	5.6	3.9	2.6		1.6	3.5			2.5
48.0	4.9	3.4	2.4	4.8	3.6	2.5	4.8	3.7	2.5			3.2	2.6		2.3
50.0	4.2	3.2	2.3	4.0	3.4	2.4	4.0	3.6	2.4			3.0	2.5		2.1
54.0	2.8	2.9	2.1	2.6	3.1	2.2	2.6	3.2	2.3			2.6	2.2		1.7
58.0		2.6	2.0		2.8	2.0		2.9	2.1			2.3	1.9		
62.0		2.2	1.8			1.9			2.0				1.6		
66.0			1.7												
θ (°)	51~ 83	54~ 84.5	56~ 84.5	54~ 83	61~ 84.5	65~ 84.5	57~ 83	64~ 84.5	68~ 84.5	65~ 83	66~ 84.5	70~ 84.5	80~ 83	70~ 84.5	80~ 84.5
標準フック	12.2t														
フック重量	440kg														
標準巻掛本数	1														

PS+油圧チルトジブ

カウンタウエイト 58t、アウトリガ張出幅 8.0m

PS+ブーム+2.0m+3.5m油圧チルトジブ

単位:t

ブーム長さ(m) 作業半径 (m)	40.4			45.4			50.5			55.6			60.0		
	オフセット			オフセット			オフセット			オフセット			オフセット		
	0°	20°	40°	0°	20°	40°	0°	20°	40°	0°	20°	40°	0°	20°	40°
8.0	58.6														
9.0	58.6	58.6		52.9											
10.0	58.6	58.6	53.9	52.0	48.4		34.9								
11.0	58.6	57.7	52.9	50.7	47.2	45.0	33.7	30.3		28.3					
12.0	58.6	56.5	51.9	49.5	46.2	44.1	32.6	29.4	27.4	27.3	25.1		26.0		
14.0	51.6	52.8	50.2	47.3	44.4	42.5	30.6	27.8	26.1	25.5	23.6	22.4	24.3	22.5	21.4
16.0	40.9	41.9	42.5	41.4	42.3	41.1	28.9	26.4	24.9	23.9	22.2	21.2	22.8	21.3	20.3
18.0	33.3	34.0	34.6	33.7	34.5	35.1	27.4	25.2	23.9	22.5	21.1	20.1	21.5	20.2	19.3
20.0	27.5	28.2	28.6	28.0	28.7	29.1	26.1	24.1	22.9	21.3	20.0	19.2	20.4	19.2	18.4
22.0	23.1	23.6	24.0	23.5	24.1	24.5	24.3	23.1	22.1	20.2	19.1	18.4	19.4	18.3	17.6
24.0	19.5	20.0	20.3	19.9	20.4	20.7	20.7	21.2	21.4	19.3	18.2	17.6	18.5	17.5	16.9
26.0	16.6	17.0	17.2	17.0	17.4	17.7	17.8	18.2	18.5	18.4	17.5	16.9	17.6	16.8	16.2
28.0	14.1	14.5	14.7	14.6	15.0	15.2	15.3	15.7	15.9	16.0	16.3	16.3	16.1	16.1	15.6
30.0	12.1	12.4	12.5	12.5	12.8	13.0	13.2	13.6	13.8	13.9	14.2	14.4	14.0	14.4	14.6
32.0	10.0	10.4	10.5	10.6	11.0	11.2	11.5	11.8	11.9	12.1	12.4	12.6	12.2	12.5	12.7
34.0	8.3	8.6	8.6	8.9	9.2	9.3	9.8	10.1	10.3	10.5	10.8	11.0	10.7	11.0	11.1
36.0	6.8	7.0		7.4	7.6	7.7	8.2	8.5	8.7	9.0	9.3	9.5	9.1	9.5	9.6
38.0	5.4	5.6		6.0	6.2	6.3	6.9	7.1	7.2	7.6	7.9	8.0	7.8	8.1	8.2
40.0	4.2	4.3		4.8	5.0		5.7	5.9	6.0	6.4	6.7	6.8	6.6	6.8	7.0
42.0	3.2			3.8	3.9		4.6	4.8	4.8	5.3	5.6	5.6	5.5	5.7	5.8
44.0				2.8	2.9		3.6	3.8		4.4	4.6	4.6	4.5	4.7	4.8
46.0							2.8	2.9		3.5	3.7	3.7	3.6	3.8	3.9
48.0							2.0	2.1		2.7	2.8		2.8	3.0	3.0
50.0										2.0	2.1		2.1	2.2	
θ(°)	18~ 84.5	27~ 84.5	43~ 84.5	28~ 84.5	29~ 84.5	42~ 84.5	30~ 84.5	30~ 84.5	42~ 84.5	35~ 84.5	35~ 84.5	42~ 84.5	41~ 84.5	42~ 84.5	45~ 84.5
標準フック	80t						35t								
フック重量	1550kg						950kg								
標準巻掛本数	5						3								

カウンタウエイト 58t、アウトリガ張出幅 8.0m

PS+ブーム+2.0m+11.5m油圧チルトジブ

単位:t

ブーム長さ(m) 作業半径 (m)	40.4			45.4			50.5			55.6			60.0		
	オフセット			オフセット			オフセット			オフセット			オフセット		
	0°	20°	40°	0°	20°	40°	0°	20°	40°	0°	20°	40°	0°	20°	40°
10.0	45.4														
11.0	45.4			36.6											
12.0	44.8			36.6			27.9								
14.0	42.2	32.1		36.6	30.8		25.8			22.3			19.5		
16.0	39.8	30.6	24.5	36.6	29.6		24.0	19.0		20.7	17.0		19.5		
18.0	34.3	29.3	23.9	34.7	28.4	24.2	22.5	18.0	15.5	19.3	16.0		18.4	15.4	
20.0	28.6	28.1	23.3	29.0	27.4	23.5	21.1	17.1	14.9	18.1	15.2	13.5	17.3	14.6	
22.0	24.1	26.1	22.8	24.5	26.4	22.8	19.9	16.4	14.3	17.0	14.4	12.9	16.3	13.9	12.4
24.0	20.5	22.3	22.3	20.9	22.6	22.3	18.8	15.7	13.8	16.1	13.7	12.4	15.4	13.2	11.9
26.0	17.6	19.2	20.4	18.0	19.5	20.8	17.9	15.0	13.4	15.2	13.1	11.9	14.6	12.6	11.4
28.0	15.2	16.5	17.6	15.5	16.9	18.0	15.9	14.4	12.9	14.4	12.6	11.4	13.9	12.1	11.0
30.0	13.1	14.3	15.3	13.4	14.7	15.6	13.8	13.9	12.5	13.7	12.0	11.0	13.1	11.6	10.6
32.0	11.4	12.4	13.2	11.7	12.8	13.6	12.1	13.2	12.2	12.5	11.6	10.6	12.1	11.1	10.3
34.0	9.6	10.8	11.5	10.0	11.1	11.9	10.5	11.5	11.9	11.0	11.1	10.3	10.9	10.5	9.9
36.0	8.1	9.2	9.9	8.5	9.6	10.3	9.0	10.1	10.8	9.5	10.6	10.0	9.4	9.8	9.5
38.0	6.8	7.7	8.4	7.1	8.2	8.9	7.6	8.7	9.4	8.2	9.3	9.7	8.1	9.2	8.9
40.0	5.6	6.4	6.9	5.9	6.9	7.5	6.4	7.4	8.1	7.0	8.0	8.7	6.9	7.9	8.4
42.0	4.5	5.3	5.6	4.9	5.7	6.2	5.3	6.2	6.8	5.9	6.8	7.4	5.8	6.7	7.4
44.0	3.6	4.2		3.9	4.6	5.1	4.4	5.2	5.7	4.9	5.7	6.3	4.8	5.7	6.3
46.0	2.7	3.2		3.0	3.7	4.0	3.5	4.2	4.7	4.0	4.8	5.3	3.9	4.7	5.3
48.0					2.8		2.7	3.4	3.7	3.2	3.9	4.4	3.1	3.9	4.4
50.0							2.0	2.6	2.8	2.5	3.1	3.5	2.4	3.1	3.5
54.0											1.7	2.0		1.7	2.0
θ(°)	29~ 83	33~ 84.5	44~ 84.5	38~ 83	38~ 84.5	44~ 84.5	38~ 83	42~ 84.5	43~ 84.5	44~ 83	42~ 84.5	43~ 84.5	48~ 83	46~ 84.5	48~ 84.5
標準フック	80t						35t								
フック重量	1550kg						950kg								
標準巻掛本数	4						3								

カウンタウエイト 58t、アウトリガ張出幅 8.0m

PS+ブーム+2.0m+17.5m油圧チルトジブ

単位:t

ブーム長さ(m) 作業半径 (m)	40.4			45.4			50.5			55.6			60.0		
	オフセット			オフセット			オフセット			オフセット			オフセット		
	0°	20°	40°	0°	20°	40°	0°	20°	40°	0°	20°	40°	0°	20°	40°
11.0	32.6														
12.0	32.6			28.2											
14.0	32.6			28.2			21.7								
16.0	31.2	21.3		28.2			21.0			16.9				14.4	
18.0	29.4	20.2		28.1	20.7		19.6	14.9		16.9				14.0	
20.0	27.9	19.2		26.9	19.8		18.3	14.1		15.9	12.7			13.6	
22.0	25.0	18.3	14.0	25.0	18.9		17.2	13.4		14.9	12.1			13.1	11.6
24.0	21.3	17.5	13.6	21.4	18.0	13.8	16.2	12.8	11.0	14.0	11.5			12.7	11.1
26.0	18.4	16.7	13.3	18.5	17.3	13.5	15.3	12.3	10.6	13.2	10.9	9.6		12.1	10.6
28.0	15.9	16.1	12.9	16.0	16.6	13.1	14.5	11.8	10.2	12.5	10.4	9.2		11.6	10.1
30.0	13.8	15.4	12.7	13.9	15.8	12.9	13.8	11.3	9.9	11.9	10.0	8.9		11.1	9.7
32.0	12.1	13.7	12.4	12.1	13.8	12.6	12.6	10.9	9.6	11.3	9.6	8.6		10.6	9.3
34.0	10.5	12.0	12.2	10.6	12.1	12.4	11.0	10.5	9.3	10.8	9.2	8.3		9.8	8.9
36.0	9.0	10.5	11.6	9.1	10.6	11.8	9.5	10.1	9.1	9.8	8.8	8.0		9.1	8.4
38.0	7.6	9.2	10.1	7.7	9.3	10.3	8.2	9.7	8.8	8.5	8.5	7.8		8.3	7.8
40.0	6.4	7.8	8.8	6.5	8.0	9.0	7.0	8.5	8.6	7.3	8.2	7.5		7.1	7.3
42.0	5.3	6.6	7.5	5.4	6.8	7.8	5.9	7.3	8.3	6.2	7.6	7.3		6.0	6.9
44.0	4.4	5.5	6.2	4.4	5.7	6.5	4.9	6.2	7.1	5.2	6.5	7.1		5.0	6.4
46.0	3.5	4.5	5.1	3.6	4.7	5.4	4.0	5.2	6.0	4.3	5.5	6.4		4.1	5.4
48.0	2.7	3.6	4.0	2.8	3.8	4.4	3.2	4.3	5.0	3.5	4.6	5.4		3.3	4.5
50.0		2.7		2.1	3.0	3.5	2.5	3.5	4.1	2.8	3.8	4.5		2.6	3.7
54.0					1.5			2.0	2.4	1.5	2.4	2.9			2.2
58.0												1.5			
θ(°)	36~83	38~84.5	44~84.5	39~83	38~84.5	48~84.5	45~83	44~84.5	47~84.5	45~83	49~84.5	47~84.5	52~83	53~84.5	56~84.5
標準フック	35t						35t								
フック重量	950kg						950kg								
標準巻掛本数	3						2								

カウンタウエイト 58t、アウトリガ張出幅 8.0m

PS+ブーム+2.0m+23.5m油圧チルトジブ

単位:t

ブーム長さ(m) 作業半径 (m)	40.4			45.4			50.5			55.6			60.0		
	オフセット			オフセット			オフセット			オフセット			オフセット		
	0°	20°	40°	0°	20°	40°	0°	20°	40°	0°	20°	40°	0°	20°	40°
12.0	24.7														
14.0	24.7			21.4			16.6								
16.0	24.7			21.4			16.6			12.7					
18.0	24.3			21.4			16.6			12.7				10.4	
20.0	23.0	14.4		21.4			16.1			12.7				10.0	
22.0	21.7	13.6		21.1	14.0		15.1	11.3		12.7				9.6	
24.0	20.1	12.9		20.1	13.3		14.1	10.8		12.4	9.8			9.2	
26.0	18.6	12.3	9.3	19.0	12.7		13.3	10.3		11.7	9.4			8.8	9.0
28.0	16.5	11.7	9.0	16.5	12.1	9.1	12.6	9.9		11.0	8.9			8.3	8.6
30.0	14.4	11.2	8.7	14.4	11.6	8.9	12.0	9.5	8.1	10.4	8.5	7.4		7.9	8.2
32.0	12.6	10.7	8.5	12.6	11.2	8.6	11.4	9.1	7.8	9.9	8.1	7.1		7.4	7.7
34.0	11.1	10.3	8.3	11.1	10.7	8.4	10.8	8.7	7.6	9.4	7.8	6.9		7.0	7.3
36.0	9.6	9.9	8.1	9.6	10.3	8.2	9.9	8.4	7.3	8.9	7.5	6.6		6.6	6.8
38.0	8.3	9.6	7.9	8.3	10.0	8.1	8.5	8.1	7.1	8.5	7.2	6.4		6.1	6.5
40.0	7.1	9.0	7.7	7.1	9.0	7.9	7.3	7.8	6.9	7.5	6.9	6.2		5.8	6.1
42.0	6.0	7.7	7.6	6.0	7.8	7.7	6.2	7.6	6.7	6.4	6.7	6.0		5.4	5.8
44.0	5.0	6.6	7.5	5.0	6.7	7.6	5.2	6.9	6.6	5.4	6.4	5.8		5.0	5.5
46.0	4.1	5.6	6.7	4.1	5.7	6.9	4.3	5.9	6.4	4.5	6.1	5.6		4.3	5.1
48.0	3.3	4.6	5.6	3.3	4.7	5.8	3.5	5.0	6.1	3.7	5.2	5.5		3.5	4.8
50.0	2.6	3.8	4.6	2.6	3.9	4.8	2.8	4.2	5.2	3.0	4.4	5.3		2.7	4.2
54.0		2.2	2.7		2.4	3.1		2.7	3.5		2.9	3.8			2.7
58.0					1.5			2.0				2.3			
θ(°)	40~83	41~84.5	45~84.5	46~83	48~84.5	45~84.5	50~83	52~84.5	51~84.5	53~83	56~84.5	56~84.5	56~83	59~84.5	63~84.5
標準フック	35t						35t								
フック重量	950kg						950kg								
標準巻掛本数	3						2								

PS+油圧チルトジブ

カウンタウエイト 58t、アウトリガ張出幅 8.0m

PS+ブーム+2.0m+29.5m油圧チルトジブ

単位:t

ブーム長さ(m) 作業半径 (m)	40.4			45.4			50.5			55.6			60.0		
	オフセット			オフセット			オフセット			オフセット			オフセット		
	0°	20°	40°	0°	20°	40°	0°	20°	40°	0°	20°	40°	0°	20°	40°
14.0	18.7			16.1											
16.0	18.7			16.1			12.4								
18.0	18.7			16.1			12.4							7.0	
20.0	18.7			16.1			12.4			8.7				6.7	
22.0	17.8			16.1			12.4			8.7				6.3	
24.0	16.5	10.2		16.1	10.5		12.4			8.7				6.0	
26.0	15.2	9.6		15.7	9.9		11.8	8.9		8.6				5.6	
28.0	14.1	9.1		15.1	9.4		11.1	8.5		8.4	8.0			5.3	
30.0	13.1	8.7		14.1	9.0		10.5	8.1		8.3	7.6			4.9	6.7
32.0	12.2	8.3	6.2	12.9	8.6	6.3	10.0	7.8		8.1	7.3			4.6	6.3
34.0	11.4	7.9	6.0	11.3	8.2	6.1	9.5	7.5	6.2	7.9	6.9			4.2	5.9
36.0	10.0	7.6	5.9	9.9	7.9	6.0	9.0	7.2	6.0	7.7	6.6	5.8		3.9	5.5
38.0	8.6	7.2	5.7	8.5	7.5	5.8	8.6	6.9	5.9	7.5	6.4	5.6	3.5	5.2	4.4
40.0	7.4	6.9	5.5	7.3	7.2	5.6	7.4	6.6	5.7	7.3	6.1	5.4	3.2	4.9	4.2
42.0	6.3	6.7	5.4	6.2	7.0	5.5	6.4	6.4	5.6	6.7	5.8	5.2	2.9	4.6	4.0
44.0	5.3	6.4	5.3	5.2	6.7	5.4	5.4	6.2	5.4	5.8	5.6	5.0	2.6	4.3	3.8
46.0	4.4	6.2	5.1	4.4	6.3	5.2	4.5	6.0	5.2	4.9	5.4	4.8	2.3	4.1	3.6
48.0	3.6	5.4	5.0	3.5	5.4	5.1	3.7	5.6	5.1	4.0	5.2	4.6	2.1	3.9	3.4
50.0	2.9	4.5	5.0	2.8	4.5	5.0	2.9	4.7	5.0	3.3	5.0	4.4	1.8	3.6	3.3
54.0	1.6	2.9	4.0		3.0	4.1		3.2	4.4		3.6	4.0		3.2	3.0
58.0		1.6	2.3		1.6	2.5			2.8			3.3			2.7
θ(°)	41~ 83	44~ 84.5	49~ 84.5	50~ 83	50~ 84.5	55~ 84.5	54~ 83	58~ 84.5	59~ 84.5	57~ 83	61~ 84.5	63~ 84.5	59~ 83	63~ 84.5	65~ 84.5
標準フック	35t									12.2t					
フック重量	950kg									440kg					
標準巻掛本数	2									1					

カウンタウエイト 58t、アウトリガ張出幅 8.0m

PS+ブーム+2.0m+35.5m油圧チルトジブ

単位:t

ブーム長さ(m) 作業半径 (m)	40.4			45.4			50.5			55.6			60.0		
	オフセット			オフセット			オフセット			オフセット			オフセット		
	0°	20°	40°	0°	20°	40°	0°	20°	40°	0°	20°	40°	0°	20°	40°
14.0	14.1														
16.0	14.1			12.2											
18.0	14.1			12.2			8.8								
20.0	14.1			12.2			8.8			6.1				4.4	
22.0	14.1			12.2			8.8			6.1				4.2	
24.0	13.9			12.2			8.8			6.1				3.8	
26.0	13.0	7.9		12.2			8.8			6.0				3.5	
28.0	12.0	7.5		12.2	7.7		8.8			5.8				3.2	
30.0	11.1	7.1		11.8	7.3		8.8	7.4		5.7				2.9	
32.0	10.3	6.7		11.1	6.9		8.8	7.1		5.5	6.5			2.6	5.4
34.0	9.6	6.4		10.3	6.6		8.8	6.8		5.3	6.2			2.2	5.0
36.0	8.9	6.1	4.5	9.7	6.3		8.3	6.5		5.2	5.9			1.9	4.7
38.0	8.4	5.8	4.3	8.9	6.0	4.4	7.9	6.2		5.0	5.6			1.6	4.4
40.0	7.8	5.5	4.2	7.7	5.7	4.2	7.5	6.0	4.5	4.8	5.4				4.1
42.0	6.8	5.3	4.0	6.6	5.5	4.1	6.9	5.7	4.4	4.6	5.1	4.4			3.9
44.0	5.8	5.0	3.9	5.6	5.3	4.0	5.9	5.5	4.3	4.3	4.9	4.2			3.6
46.0	4.9	4.8	3.8	4.7	5.0	3.9	5.0	5.3	4.1	4.1	4.6	4.0			3.4
48.0	4.1	4.6	3.7	3.9	4.8	3.7	4.2	5.1	4.0	3.9	4.3	3.8			3.2
50.0	3.3	4.4	3.6	3.2	4.7	3.7	3.5	4.9	3.9	3.5	4.1	3.6			3.0
54.0	2.0	3.7	3.4		3.7	3.5		4.0	3.7		3.7	3.2			2.6
58.0		2.4	3.3		2.3	3.3		2.7	3.6		2.8	2.9			2.0
62.0			2.1			2.2			2.6			2.6			
θ(°)	47~ 83	52~ 84.5	53~ 84.5	54~ 83	56~ 84.5	58~ 84.5	57~ 83	59~ 84.5	62~ 84.5	60~ 83	62~ 84.5	65~ 84.5	70~ 83	67~ 84.5	70~ 84.5
標準フック	35t									12.2t					
フック重量	950kg									440kg					
標準巻掛本数	2									1					

カウンタウエイト 58t、アウトリガ張出幅 6.8m

PS+ブーム+2.0m+3.5m油圧チルトジブ

単位:t

ブーム長さ(m) 作業半径 (m)	40.4			45.4			50.5			55.6			60.0		
	オフセット			オフセット			オフセット			オフセット			オフセット		
	0°	20°	40°	0°	20°	40°	0°	20°	40°	0°	20°	40°	0°	20°	40°
8.0	58.6														
9.0	58.6	58.6		52.9											
10.0	58.6	58.6	53.9	52.0	48.4		34.9								
11.0	58.6	57.7	52.9	50.7	47.2	45.0	33.7	30.3		28.3					
12.0	55.5	56.5	51.9	49.5	46.2	44.1	32.6	29.4	27.4	27.3	25.1		26.0		
14.0	42.6	43.7	44.5	43.1	44.2	42.5	30.6	27.8	26.1	25.5	23.6	22.4	24.3	22.5	21.4
16.0	33.8	34.7	35.4	34.3	35.2	35.8	28.9	26.4	24.9	23.9	22.2	21.2	22.8	21.3	20.3
18.0	27.5	28.2	28.7	27.9	28.7	29.2	27.4	25.2	23.9	22.5	21.1	20.1	21.5	20.2	19.3
20.0	22.6	23.3	23.7	23.1	23.7	24.2	23.9	24.1	22.9	21.3	20.0	19.2	20.4	19.2	18.4
22.0	18.8	19.4	19.7	19.3	19.8	20.2	20.0	20.6	20.9	20.2	19.1	18.4	19.4	18.3	17.6
24.0	15.8	16.2	16.5	16.2	16.7	17.0	17.0	17.4	17.7	17.6	18.1	17.6	17.8	17.5	16.9
26.0	13.3	13.7	13.9	13.7	14.1	14.4	14.4	14.8	15.1	15.1	15.5	15.7	15.2	15.6	15.9
28.0	11.0	11.5	11.7	11.6	12.0	12.2	12.3	12.7	12.9	12.9	13.3	13.5	13.1	13.5	13.7
30.0	9.0	9.4	9.5	9.6	10.0	10.2	10.4	10.8	11.0	11.1	11.5	11.7	11.3	11.6	11.8
32.0	7.2	7.5	7.7	7.8	8.1	8.3	8.7	9.0	9.2	9.4	9.8	10.0	9.6	10.0	10.2
34.0	5.7	6.0	6.0	6.3	6.6	6.7	7.1	7.5	7.6	7.9	8.2	8.4	8.1	8.4	8.6
36.0	4.4	4.6		4.9	5.2	5.3	5.8	6.1	6.2	6.6	6.8	7.0	6.7	7.0	7.2
38.0	3.2	3.3		3.8	4.0	4.0	4.6	4.9	5.0	5.4	5.6	5.8	5.5	5.8	5.9
40.0				2.7	2.9		3.6	3.8	3.8	4.3	4.5	4.6	4.4	4.7	4.8
42.0							2.6	2.8	2.8	3.3	3.5	3.6	3.5	3.7	3.8
44.0							1.8	1.9		2.5	2.7	2.7	2.6	2.8	2.9
46.0										1.7	1.9	1.9	1.8	2.0	2.1
θ (°)	32~ 84.5	33~ 84.5	43~ 84.5	37~ 84.5	38~ 84.5	42~ 84.5	38~ 84.5	38~ 84.5	42~ 84.5	41~ 84.5	42~ 84.5	42~ 84.5	46~ 84.5	47~ 84.5	48~ 84.5
標準フック	80t						35t								
フック重量	1550kg						950kg								
標準巻掛本数	5						3								

カウンタウエイト 58t、アウトリガ張出幅 6.8m

PS+ブーム+2.0m+11.5m油圧チルトジブ

単位:t

ブーム長さ(m) 作業半径 (m)	40.4			45.4			50.5			55.6			60.0		
	オフセット			オフセット			オフセット			オフセット			オフセット		
	0°	20°	40°	0°	20°	40°	0°	20°	40°	0°	20°	40°	0°	20°	40°
10.0	45.4														
11.0	45.4			36.6											
12.0	44.8			36.6			27.9								
14.0	42.2	32.1		36.6	30.8		25.8			22.3			19.5		
16.0	34.8	30.6	24.5	35.2	29.6		24.0	19.0		20.7	17.0		19.5		
18.0	28.5	29.3	23.9	28.8	28.4	24.2	22.5	18.0	15.5	19.3	16.0		18.4	15.4	
20.0	23.6	25.8	23.3	24.0	26.2	23.5	21.1	17.1	14.9	18.1	15.2	13.5	17.3	14.6	
22.0	19.8	21.8	22.8	20.2	22.1	22.8	19.9	16.4	14.3	17.0	14.4	12.9	16.3	13.9	12.4
24.0	16.8	18.5	19.8	17.1	18.8	20.2	17.5	15.7	13.8	16.1	13.7	12.4	15.4	13.2	11.9
26.0	14.3	15.8	17.0	14.6	16.1	17.3	15.0	15.0	13.4	15.2	13.1	11.9	14.6	12.6	11.4
28.0	12.2	13.5	14.5	12.5	13.8	14.9	12.9	14.2	12.9	13.3	12.6	11.4	13.2	12.1	11.0
30.0	10.3	11.6	12.5	10.6	11.9	12.8	11.1	12.3	12.5	11.5	12.0	11.0	11.4	11.6	10.6
32.0	8.5	9.9	10.7	8.9	10.2	11.1	9.4	10.6	11.5	9.9	11.1	10.6	9.8	11.0	10.3
34.0	7.0	8.2	9.1	7.4	8.6	9.5	7.8	9.1	9.9	8.4	9.6	10.3	8.3	9.6	9.9
36.0	5.7	6.7	7.5	6.0	7.2	8.0	6.5	7.7	8.5	7.1	8.2	9.0	6.9	8.1	9.0
38.0	4.5	5.4	6.1	4.8	5.9	6.6	5.3	6.4	7.1	5.9	6.9	7.7	5.8	6.9	7.7
40.0	3.4	4.3	4.8	3.8	4.7	5.3	4.3	5.2	5.9	4.8	5.8	6.5	4.7	5.7	6.5
42.0	2.5	3.2	3.6	2.8	3.7	4.2	3.3	4.2	4.8	3.9	4.7	5.4	3.7	4.7	5.4
44.0					2.7	3.1	2.5	3.3	3.8	3.0	3.8	4.4	2.9	3.8	4.4
46.0							1.7	2.4	2.8	2.2	3.0	3.4		2.9	3.4
48.0								1.6	2.0		2.2	2.6		2.1	2.6
50.0												1.8			
θ (°)	37~ 83	42~ 84.5	44~ 84.5	44~ 83	45~ 84.5	47~ 84.5	44~ 83	45~ 84.5	46~ 84.5	48~ 83	50~ 84.5	49~ 84.5	54~ 83	53~ 84.5	55~ 84.5
標準フック	80t						35t								
フック重量	1550kg						950kg								
標準巻掛本数	4						3								

PS+油圧チルトジブ

カウンタウエイト 58t、アウトリガ張出幅 6.8m

PS+ブーム+2.0m+17.5m油圧チルトジブ

単位:t

ブーム長さ(m) 作業半径 (m)	40.4			45.4			50.5			55.6			60.0					
	オフセット			オフセット			オフセット			オフセット			オフセット					
	0°	20°	40°	0°	20°	40°	0°	20°	40°	0°	20°	40°	0°	20°	40°			
11.0	32.6																	
12.0	32.6			28.2														
14.0	32.6			28.2			21.7											
16.0	31.2	21.3		28.2			21.0			16.9				14.4				
18.0	29.3	20.2		28.1	20.7		19.6	14.9		16.9				14.0				
20.0	24.5	19.2		24.5	19.8		18.3	14.1		15.9	12.7			13.6				
22.0	20.6	18.3	14.0	20.7	18.9		17.2	13.4		14.9	12.1			13.1	11.6			
24.0	17.5	17.5	13.6	17.6	18.0	13.8	16.2	12.8	11.0	14.0	11.5			12.7	11.1			
26.0	15.0	16.7	13.3	15.1	17.3	13.5	15.3	12.3	10.6	13.2	10.9	9.6		12.1	10.6	9.3		
28.0	12.9	14.9	12.9	12.9	15.0	13.1	13.4	11.8	10.2	12.5	10.4	9.2		11.6	10.1	8.9		
30.0	11.1	12.9	12.7	11.1	13.0	12.9	11.6	11.3	9.9	11.8	10.0	8.9		11.1	9.7	8.6		
32.0	9.4	11.1	12.4	9.4	11.2	12.6	9.9	10.9	9.6	10.2	9.6	8.6		10.0	9.3	8.3		
34.0	7.8	9.6	10.8	7.9	9.7	11.0	8.4	10.1	9.3	8.7	9.2	8.3		8.5	8.9	8.0		
36.0	6.5	8.2	9.4	6.6	8.3	9.5	7.1	8.8	9.1	7.3	8.8	8.0		7.2	8.4	7.6		
38.0	5.3	6.8	8.0	5.4	7.0	8.2	5.9	7.5	8.7	6.1	7.8	7.8		6.0	7.6	7.3		
40.0	4.2	5.6	6.6	4.3	5.8	6.9	4.8	6.3	7.4	5.1	6.6	7.5		4.9	6.5	7.0		
42.0	3.3	4.5	5.4	3.4	4.7	5.7	3.8	5.2	6.2	4.1	5.5	6.6		3.9	5.4	6.5		
44.0	2.4	3.5	4.3	2.5	3.7	4.6	3.0	4.2	5.2	3.3	4.5	5.5		3.1	4.4	5.4		
46.0		2.6	3.2	1.7	2.8	3.6	2.2	3.4	4.2	2.5	3.7	4.5			3.6	4.5		
48.0					2.0	2.7		2.5	3.3		2.9	3.6			2.8	3.6		
50.0						1.8		1.8	2.4		2.1	2.8				2.8		
θ(°)	42~ 83	45~ 84.5	48~ 84.5	45~ 83	48~ 84.5	48~ 84.5	49~ 83	50~ 84.5	53~ 84.5	53~ 83	54~ 84.5	57~ 84.5	58~ 83	59~ 84.5	60~ 84.5			
標準フック	35t						35t											
フック重量	950kg						950kg											
標準巻掛本数	3						2											

カウンタウエイト 58t、アウトリガ張出幅 6.8m

PS+ブーム+2.0m+23.5m油圧チルトジブ

単位:t

ブーム長さ(m) 作業半径 (m)	40.4			45.4			50.5			55.6			60.0					
	オフセット			オフセット			オフセット			オフセット			オフセット					
	0°	20°	40°	0°	20°	40°	0°	20°	40°	0°	20°	40°	0°	20°	40°			
12.0	24.7																	
14.0	24.7			21.4			16.6											
16.0	24.7			21.4			16.6			12.7								
18.0	24.3			21.4			16.6			12.7				10.4				
20.0	23.0	14.4		21.4			16.1			12.7				10.0				
22.0	21.3	13.6		21.1	14.0		15.1	11.3		12.7				9.6				
24.0	18.2	12.9		18.2	13.3		14.1	10.8		12.4	9.8			9.2				
26.0	15.6	12.3	9.3	15.6	12.7		13.3	10.3		11.7	9.4			8.8	9.0			
28.0	13.5	11.7	9.0	13.5	12.1	9.1	12.6	9.9		11.0	8.9			8.3	8.6			
30.0	11.6	11.2	8.7	11.6	11.6	8.9	11.8	9.5	8.1	10.4	8.5	7.4		7.9	8.2			
32.0	10.0	10.7	8.5	10.0	11.2	8.6	10.2	9.1	7.8	9.9	8.1	7.1		7.4	7.7	6.5		
34.0	8.5	10.3	8.3	8.5	10.7	8.4	8.7	7.6	8.9	7.8	6.9	7.0		7.3	6.2			
36.0	7.1	9.3	8.1	7.1	9.3	8.2	7.4	8.4	7.3	7.5	6.6	6.6		6.8	5.9			
38.0	5.9	8.0	7.9	5.9	8.1	8.1	6.2	8.1	7.1	6.3	7.2	6.4		6.1	6.5	5.7		
40.0	4.9	6.8	7.7	4.9	6.8	7.9	5.1	7.1	6.9	5.3	6.9	6.2		5.1	6.1	5.4		
42.0	3.9	5.7	7.0	3.9	5.7	7.2	4.1	6.0	6.7	4.3	6.2	6.0		4.1	5.8	5.1		
44.0	3.0	4.6	5.9	3.0	4.7	6.0	3.3	5.0	6.3	3.4	5.2	5.8		3.2	5.0	4.9		
46.0	2.3	3.7	4.8	2.3	3.8	5.0	2.5	4.1	5.3	2.7	4.3	5.5			4.1	4.7		
48.0	1.5	2.9	3.8		3.0	4.0		3.2	4.4		3.4	4.6			3.3	4.5		
50.0		2.1	2.9		2.2	3.1		2.5	3.5		2.7	3.8				3.7		
θ(°)	43~ 83	47~ 84.5	52~ 84.5	50~ 83	53~ 84.5	57~ 84.5	54~ 83	56~ 84.5	61~ 84.5	57~ 83	60~ 84.5	64~ 84.5	61~ 83	64~ 84.5	66~ 84.5			
標準フック	35t						35t											
フック重量	950kg						950kg											
標準巻掛本数	3						2											

カウンタウエイト 58t、アウトリガ張出幅 6.8m

PS+ブーム+2.0m+29.5m油圧チルトジブ

単位:t

ブーム長さ(m) 作業半径 (m)	40.4			45.4			50.5			55.6			60.0		
	オフセット			オフセット			オフセット			オフセット			オフセット		
	0°	20°	40°	0°	20°	40°	0°	20°	40°	0°	20°	40°	0°	20°	40°
14.0	18.7			16.1											
16.0	18.7			16.1			12.4								
18.0	18.7			16.1			12.4			8.7				7.0	
20.0	18.7			16.1			12.4			8.7				6.7	
22.0	17.8			16.1			12.4			8.7				6.3	
24.0	16.5	10.2		16.1	10.5		12.4			8.7				6.0	
26.0	15.2	9.6		15.7	9.9		11.8	8.9		8.6				5.6	
28.0	13.8	9.1		13.7	9.4		11.1	8.5		8.4	8.0			5.3	
30.0	11.9	8.7		11.9	9.0		10.5	8.1		8.3	7.6			4.9	6.7
32.0	10.4	8.3	6.2	10.3	8.6	6.3	10.0	7.8		8.1	7.3			4.6	6.3
34.0	8.8	7.9	6.0	8.7	8.2	6.1	8.9	7.5	6.2	7.9	6.9			4.2	5.9
36.0	7.5	7.6	5.9	7.4	7.9	6.0	7.5	7.2	6.0	7.7	6.6	5.8		3.9	5.5
38.0	6.3	7.2	5.7	6.2	7.5	5.8	6.3	6.9	5.9	6.7	6.4	5.6	3.5	5.2	4.4
40.0	5.2	6.9	5.5	5.1	7.2	5.6	5.2	6.6	5.7	5.6	6.1	5.4	3.2	4.9	4.2
42.0	4.2	6.4	5.4	4.1	6.4	5.5	4.3	6.4	5.6	4.7	5.8	5.2	2.9	4.6	4.0
44.0	3.4	5.4	5.3	3.3	5.4	5.4	3.4	5.5	5.4	3.8	5.6	5.0		4.3	3.8
46.0	2.6	4.5	5.1	2.5	4.5	5.2		4.6	5.2		5.0	4.8		4.1	3.6
48.0	1.9	3.6	5.0		3.6	5.1		3.8	5.1		4.2	4.6		3.9	3.4
50.0		2.8	4.1		2.8	4.2		3.0	4.4		3.4	4.4			3.3
54.0			2.4			2.6			2.8			3.3			
θ(°)	48~ 83	55~ 84.5	55~ 84.5	54~ 83	58~ 84.5	60~ 84.5	59~ 83	61~ 84.5	63~ 84.5	62~ 83	64~ 84.5	66~ 84.5	65~ 83	68~ 84.5	72~ 84.5
標準フック	35t											12.2t			
フック重量	950kg											440kg			
標準巻掛本数	2											1			

カウンタウエイト 58t、アウトリガ張出幅 6.8m

PS+ブーム+2.0m+35.5m油圧チルトジブ

単位:t

ブーム長さ(m) 作業半径 (m)	40.4			45.4			50.5			55.6			60.0		
	オフセット			オフセット			オフセット			オフセット			オフセット		
	0°	20°	40°	0°	20°	40°	0°	20°	40°	0°	20°	40°	0°	20°	40°
14.0	14.1														
16.0	14.1			12.2											
18.0	14.1			12.2			8.8								
20.0	14.1			12.2			8.8			6.1				4.4	
22.0	14.1			12.2			8.8			6.1				4.2	
24.0	13.9			12.2			8.8			6.1				3.8	
26.0	13.0	7.9		12.2			8.8			6.0				3.5	
28.0	12.0	7.5		12.2	7.7		8.8			5.8				3.2	
30.0	11.1	7.1		11.8	7.3		8.8	7.4		5.7				2.9	
32.0	10.3	6.7		10.6	6.9		8.8	7.1		5.5	6.5			2.6	5.4
34.0	9.3	6.4		9.1	6.6		8.8	6.8		5.3	6.2			2.2	5.0
36.0	7.9	6.1	4.5	7.7	6.3		8.1	6.5		5.2	5.9			1.9	4.7
38.0	6.7	5.8	4.3	6.5	6.0	4.4	6.9	6.2		5.0	5.6			1.6	4.4
40.0	5.6	5.5	4.2	5.5	5.7	4.2	5.8	6.0	4.5	4.8	5.4				4.1
42.0	4.7	5.3	4.0	4.5	5.5	4.1	4.8	5.7	4.4	4.6	5.1	4.4		3.9	3.3
44.0	3.8	5.0	3.9	3.6	5.3	4.0	4.0	5.5	4.3	4.0	4.9	4.2		3.6	3.1
46.0	3.0	4.8	3.8	2.8	5.0	3.9	3.2	5.3	4.1		4.6	4.0		3.4	2.9
48.0	2.3	4.4	3.7		4.3	3.7		4.7	4.0		4.3	3.8		3.2	2.7
50.0		3.6	3.6		3.5	3.7		3.9	3.9		4.0	3.6		3.0	2.6
54.0		2.2	3.4			3.5			3.7			3.2			2.3
θ(°)	53~ 83	56~ 84.5	63~ 84.5	58~ 83	63~ 84.5	66~ 84.5	60~ 83	66~ 84.5	69~ 84.5	64~ 83	68~ 84.5	72~ 84.5	70~ 83	70~ 84.5	73~ 84.5
標準フック	35t											12.2t			
フック重量	950kg											440kg			
標準巻掛本数	2											1			

PS+油圧チルトジブ

カウンタウエイト 47t、アウトリガ張出幅 8.5m

PS+ブーム+2.0m+3.5m油圧チルトジブ

単位:t

ブーム長さ(m) 作業半径 (m)	40.4			45.4			50.5			55.6			60.0		
	オフセット			オフセット			オフセット			オフセット			オフセット		
	0°	20°	40°	0°	20°	40°	0°	20°	40°	0°	20°	40°	0°	20°	40°
8.0	58.6														
9.0	58.6	58.6		52.9											
10.0	58.6	58.6	53.9	52.0	48.4		34.9								
11.0	58.6	57.7	52.9	50.7	47.2	45.0	33.7	30.3		28.3					
12.0	58.6	56.5	51.9	49.5	46.2	44.1	32.6	29.4	27.4	27.3	25.1		26.0		
14.0	47.2	48.4	49.2	47.3	44.4	42.5	30.6	27.8	26.1	25.5	23.6	22.4	24.3	22.5	21.4
16.0	37.5	38.5	39.1	38.0	38.9	39.6	28.9	26.4	24.9	23.9	22.2	21.2	22.8	21.3	20.3
18.0	30.5	31.3	31.8	31.0	31.7	32.3	27.4	25.2	23.9	22.5	21.1	20.1	21.5	20.2	19.3
20.0	25.0	25.7	26.1	25.5	26.1	26.6	26.1	24.1	22.9	21.3	20.0	19.2	20.4	19.2	18.4
22.0	20.7	21.3	21.7	21.2	21.8	22.2	22.0	22.6	22.1	20.2	19.1	18.4	19.4	18.3	17.6
24.0	17.4	17.8	18.1	17.8	18.3	18.6	18.6	19.1	19.4	19.3	18.2	17.6	18.5	17.5	16.9
26.0	14.6	15.0	15.3	15.1	15.5	15.8	15.8	16.2	16.5	16.5	16.9	16.9	16.6	16.8	16.2
28.0	12.3	12.7	12.8	12.8	13.1	13.4	13.5	13.9	14.1	14.2	14.5	14.8	14.3	14.7	14.9
30.0	10.2	10.6	10.7	10.8	11.1	11.3	11.6	11.9	12.1	12.2	12.5	12.7	12.3	12.7	12.9
32.0	8.3	8.6	8.7	8.9	9.2	9.4	9.8	10.1	10.3	10.5	10.8	11.0	10.7	11.0	11.2
34.0	6.6	6.9	7.0	7.2	7.5	7.7	8.1	8.5	8.6	8.9	9.2	9.4	9.1	9.4	9.6
36.0	5.2	5.4		5.8	6.1	6.2	6.7	7.0	7.1	7.5	7.8	7.9	7.6	7.9	8.1
38.0	4.0	4.1		4.5	4.8	4.8	5.4	5.7	5.8	6.2	6.4	6.6	6.3	6.6	6.8
40.0	2.8	2.9		3.4	3.6		4.3	4.5	4.6	5.0	5.3	5.4	5.2	5.4	5.6
42.0				2.4	2.6		3.3	3.5	3.5	4.0	4.2	4.3	4.2	4.4	4.5
44.0							2.4	2.5		3.1	3.3	3.4	3.2	3.4	3.5
46.0							1.6	1.7		2.3	2.4	2.5	2.4	2.6	2.7
48.0										1.5	1.7		1.7	1.8	1.9
θ(°)	26~ 84.5	27~ 84.5	43~ 84.5	33~ 84.5	34~ 84.5	42~ 84.5	34~ 84.5	35~ 84.5	42~ 84.5	38~ 84.5	39~ 84.5	42~ 84.5	44~ 84.5	44~ 84.5	45~ 84.5
標準フック	80t						35t								
フック重量	1550kg						950kg								
標準巻掛本数	5						3								

カウンタウエイト 47t、アウトリガ張出幅 8.5m

PS+ブーム+2.0m+11.5m油圧チルトジブ

単位:t

ブーム長さ(m) 作業半径 (m)	40.4			45.4			50.5			55.6			60.0		
	オフセット			オフセット			オフセット			オフセット			オフセット		
	0°	20°	40°	0°	20°	40°	0°	20°	40°	0°	20°	40°	0°	20°	40°
10.0	45.4														
11.0	45.4			36.6											
12.0	44.8			36.6			27.9								
14.0	42.2	32.1		36.6	30.8		25.8			22.3			19.5		
16.0	38.6	30.6	24.5	36.6	29.6		24.0	19.0		20.7	17.0		19.5		
18.0	31.6	29.3	23.9	31.9	28.4	24.2	22.5	18.0	15.5	19.3	16.0		18.4	15.4	
20.0	26.1	28.1	23.3	26.5	27.4	23.5	21.1	17.1	14.9	18.1	15.2	13.5	17.3	14.6	
22.0	21.8	23.8	22.8	22.2	24.2	22.8	19.9	16.4	14.3	17.0	14.4	12.9	16.3	13.9	12.4
24.0	18.4	20.2	21.6	18.8	20.6	22.0	18.8	15.7	13.8	16.1	13.7	12.4	15.4	13.2	11.9
26.0	15.7	17.2	18.5	16.0	17.6	18.8	16.4	15.0	13.4	15.2	13.1	11.9	14.6	12.6	11.4
28.0	13.4	14.8	15.8	13.7	15.1	16.2	14.1	14.4	12.9	14.4	12.6	11.4	13.9	12.1	11.0
30.0	11.4	12.7	13.6	11.8	13.0	14.0	12.2	13.4	12.5	12.6	12.0	11.0	12.5	11.6	10.6
32.0	9.6	10.9	11.7	10.0	11.2	12.1	10.5	11.6	12.2	11.0	11.6	10.6	10.9	11.1	10.3
34.0	8.0	9.2	10.0	8.4	9.7	10.4	8.9	10.1	10.8	9.4	10.5	10.3	9.3	10.5	9.9
36.0	6.6	7.7	8.4	6.9	8.1	8.9	7.4	8.6	9.4	8.0	9.2	9.9	7.9	9.1	9.5
38.0	5.3	6.3	6.9	5.7	6.7	7.4	6.2	7.2	8.0	6.7	7.8	8.6	6.6	7.7	8.6
40.0	4.2	5.1	5.6	4.5	5.5	6.1	5.0	6.0	6.7	5.6	6.6	7.3	5.5	6.5	7.3
42.0	3.2	3.9	4.3	3.5	4.4	4.9	4.0	4.9	5.5	4.6	5.5	6.1	4.5	5.4	6.1
44.0		2.9		2.6	3.4	3.8	3.1	3.9	4.4	3.7	4.5	5.1	3.5	4.4	5.0
46.0					2.5	2.8	2.3	3.0	3.5	2.8	3.6	4.1	2.7	3.5	4.1
48.0							1.6	2.2	2.6	2.1	2.8	3.2	2.7	3.2	3.7
50.0								1.5	1.7		2.0	2.4		2.0	2.4
θ(°)	37~ 83	38~ 84.5	44~ 84.5	41~ 83	42~ 84.5	44~ 84.5	41~ 83	42~ 84.5	43~ 84.5	46~ 83	47~ 84.5	49~ 84.5	52~ 83	51~ 84.5	53~ 84.5
標準フック	80t						35t								
フック重量	1550kg						950kg								
標準巻掛本数	4						3								

カウンタウエイト 47t、アウトリガ張出幅 8.5m

PS+ブーム+2.0m+17.5m油圧チルトジブ

単位:t

ブーム長さ(m) 作業半径 (m)	40.4			45.4			50.5			55.6			60.0		
	オフセット			オフセット			オフセット			オフセット			オフセット		
	0°	20°	40°	0°	20°	40°	0°	20°	40°	0°	20°	40°	0°	20°	40°
11.0	32.6														
12.0	32.6			28.2											
14.0	32.6			28.2			21.7								
16.0	31.2	21.3		28.2			21.0			16.9			14.4		
18.0	29.4	20.2		28.1	20.7		19.6	14.9		16.9			14.0		
20.0	27.0	19.2		26.9	19.8		18.3	14.1		15.9	12.7		13.6		
22.0	22.7	18.3	14.0	22.8	18.9		17.2	13.4		14.9	12.1		13.1	11.6	
24.0	19.3	17.5	13.6	19.3	18.0	13.8	16.2	12.8		11.0	14.0	11.5	12.7	11.1	
26.0	16.5	16.7	13.3	16.5	17.3	13.5	15.3	12.3	10.6	13.2	10.9	9.6	12.1	10.6	9.3
28.0	14.1	16.1	12.9	14.2	16.3	13.1	14.5	11.8	10.2	12.5	10.4	9.2	11.6	10.1	8.9
30.0	12.2	14.0	12.7	12.2	14.1	12.9	12.7	11.3	9.9	11.9	10.0	8.9	11.1	9.7	8.6
32.0	10.5	12.2	12.4	10.6	12.3	12.6	11.0	10.9	9.6	11.2	9.6	8.6	10.6	9.3	8.3
34.0	8.9	10.6	11.8	9.0	10.7	11.9	9.5	10.5	9.3	9.7	9.2	8.3	9.6	8.9	8.0
36.0	7.4	9.1	10.2	7.5	9.3	10.4	8.0	9.7	9.1	8.3	8.8	8.0	8.1	8.4	7.6
38.0	6.2	7.7	8.8	6.2	7.9	9.0	6.7	8.4	8.8	7.0	8.5	7.8	6.8	7.8	7.3
40.0	5.0	6.4	7.5	5.1	6.6	7.7	5.6	7.1	8.2	5.9	7.4	7.5	5.7	7.3	7.0
42.0	4.0	5.3	6.2	4.1	5.5	6.5	4.6	6.0	7.0	4.9	6.3	7.3	4.7	6.2	6.7
44.0	3.1	4.2	5.0	3.2	4.4	5.3	3.7	4.9	5.9	3.9	5.3	6.2	3.8	5.1	6.2
46.0		3.3	3.9	2.4	3.5	4.3	2.8	4.0	4.8	3.1	4.3	5.2	2.9	4.2	5.2
48.0		2.4	2.9	1.6	2.6	3.3	2.1	3.2	3.9	2.4	3.5	4.3		3.4	4.2
50.0					1.9	2.4		2.4	3.0		2.7	3.4		2.6	3.4
θ(°)	42~ 83	42~ 84.5	44~ 84.5	42~ 83	45~ 84.5	48~ 84.5	47~ 83	50~ 84.5	53~ 84.5	51~ 83	54~ 84.5	57~ 84.5	56~ 83	57~ 84.5	60~ 84.5
標準フック	35t						35t								
フック重量	950kg						950kg								
標準巻掛本数	3						2								

カウンタウエイト 47t、アウトリガ張出幅 8.5m

PS+ブーム+2.0m+23.5m油圧チルトジブ

単位:t

ブーム長さ(m) 作業半径 (m)	40.4			45.4			50.5			55.6			60.0		
	オフセット			オフセット			オフセット			オフセット			オフセット		
	0°	20°	40°	0°	20°	40°	0°	20°	40°	0°	20°	40°	0°	20°	40°
12.0	24.7														
14.0	24.7			21.4			16.6								
16.0	24.7			21.4			16.6			12.7					
18.0	24.3			21.4			16.6			12.7			10.4		
20.0	23.0	14.4		21.4			16.1			12.7			10.0		
22.0	21.7	13.6		21.1	14.0		15.1	11.3		12.7			9.6		
24.0	19.9	12.9		19.9	13.3		14.1	10.8		12.4	9.8		9.2		
26.0	17.1	12.3	9.3	17.1	12.7		13.3	10.3		11.7	9.4		8.8	9.0	
28.0	14.8	11.7	9.0	14.8	12.1	9.1	12.6	9.9		11.0	8.9		8.3	8.6	
30.0	12.8	11.2	8.7	12.8	11.6	8.9	12.0	9.5	8.1	10.4	8.5	7.4	7.9	8.2	
32.0	11.1	10.7	8.5	11.1	11.2	8.6	11.3	9.1	7.8	9.9	8.1	7.1	7.4	7.7	6.5
34.0	9.6	10.3	8.3	9.6	10.7	8.4	9.8	8.7	7.6	9.4	7.8	6.9	7.0	7.3	6.2
36.0	8.1	9.9	8.1	8.1	10.2	8.2	8.3	8.4	7.3	8.5	7.5	6.6	6.6	6.8	5.9
38.0	6.8	8.9	7.9	6.8	8.9	8.1	7.0	8.1	7.1	7.2	7.2	6.4	6.1	6.5	5.7
40.0	5.7	7.6	7.7	5.7	7.7	7.9	5.9	7.8	6.9	6.1	6.9	6.2	5.8	6.1	5.4
42.0	4.7	6.4	7.6	4.7	6.5	7.7	4.9	6.7	6.7	5.1	6.7	6.0	4.9	5.8	5.1
44.0	3.7	5.4	6.6	3.7	5.4	6.8	4.0	5.7	6.6	4.2	5.9	5.8	3.9	5.5	4.9
46.0	2.9	4.4	5.5	2.9	4.5	5.7	3.1	4.7	6.0	3.3	5.0	5.6	3.1	4.8	4.7
48.0	2.2	3.5	4.5	2.2	3.6	4.7	2.4	3.9	5.0	2.6	4.1	5.3		3.9	4.5
50.0	1.5	2.7	3.5		2.8	3.7		3.1	4.1		3.3	4.4		3.1	4.3
54.0			1.7			2.1			2.5				2.8		
θ(°)	40~ 83	47~ 84.5	45~ 84.5	48~ 83	53~ 84.5	52~ 84.5	52~ 83	56~ 84.5	56~ 84.5	55~ 83	60~ 84.5	60~ 84.5	59~ 83	62~ 84.5	66~ 84.5
標準フック	35t						35t								
フック重量	950kg						950kg								
標準巻掛本数	3						2								

PS+油圧チルトジブ

カウンタウエイト 47t、アウトリガ張出幅 8.5m

PS+ブーム+2.0m+29.5m油圧チルトジブ

単位:t

ブーム長さ(m) 作業半径 (m)	40.4			45.4			50.5			55.6			60.0		
	オフセット			オフセット			オフセット			オフセット			オフセット		
	0°	20°	40°	0°	20°	40°	0°	20°	40°	0°	20°	40°	0°	20°	40°
14.0	18.7			16.1											
16.0	18.7			16.1			12.4								
18.0	18.7			16.1			12.4							7.0	
20.0	18.7			16.1			12.4			8.7				6.7	
22.0	17.8			16.1			12.4			8.7				6.3	
24.0	16.5	10.2		16.1	10.5		12.4			8.7				6.0	
26.0	15.2	9.6		15.7	9.9		11.8	8.9		8.6				5.6	
28.0	14.1	9.1		15.0	9.4		11.1	8.5		8.4	8.0			5.3	
30.0	13.1	8.7		13.0	9.0		10.5	8.1		8.3	7.6			4.9	6.7
32.0	11.4	8.3	6.2	11.3	8.6	6.3	10.0	7.8		8.1	7.3			4.6	6.3
34.0	9.9	7.9	6.0	9.8	8.2	6.1	9.5	7.5	6.2	7.9	6.9			4.2	5.9
36.0	8.5	7.6	5.9	8.4	7.9	6.0	8.5	7.2	6.0	7.7	6.6	5.8		3.9	5.5
38.0	7.2	7.2	5.7	7.1	7.5	5.8	7.2	6.9	5.9	7.5	6.4	5.6	3.5	5.2	4.4
40.0	6.1	6.9	5.5	6.0	7.2	5.6	6.1	6.6	5.7	6.5	6.1	5.4	3.2	4.9	4.2
42.0	5.0	6.7	5.4	4.9	7.0	5.5	5.1	6.4	5.6	5.5	5.8	5.2	2.9	4.6	4.0
44.0	4.1	6.2	5.3	4.0	6.1	5.4	4.1	6.2	5.4	4.5	5.6	5.0	2.6	4.3	3.8
46.0	3.3	5.2	5.1	3.2	5.2	5.2	3.3	5.3	5.2	3.7	5.4	4.8	2.3	4.1	3.6
48.0	2.5	4.3	5.0	2.4	4.3	5.1		4.4	5.1	2.9	4.8	4.6		3.9	3.4
50.0	1.8	3.4	4.7		3.4	4.8		3.6	5.0		4.0	4.4		3.6	3.3
54.0		1.9	3.0			3.1			3.4			3.8			3.0
θ(°)	46~ 83	50~ 84.5	55~ 84.5	52~ 83	58~ 84.5	60~ 84.5	57~ 83	61~ 84.5	63~ 84.5	59~ 83	64~ 84.5	66~ 84.5	62~ 83	66~ 84.5	68~ 84.5
標準フック	35t											12.2t			
フック重量	950kg											440kg			
標準巻掛本数	2											1			

カウンタウエイト 47t、アウトリガ張出幅 8.5m

PS+ブーム+2.0m+35.5m油圧チルトジブ

単位:t

ブーム長さ(m) 作業半径 (m)	40.4			45.4			50.5			55.6			60.0		
	オフセット			オフセット			オフセット			オフセット			オフセット		
	0°	20°	40°	0°	20°	40°	0°	20°	40°	0°	20°	40°	0°	20°	40°
14.0	14.1														
16.0	14.1			12.2											
18.0	14.1			12.2			8.8								
20.0	14.1			12.2			8.8			6.1				4.4	
22.0	14.1			12.2			8.8			6.1				4.2	
24.0	13.9			12.2			8.8			6.1				3.8	
26.0	13.0	7.9		12.2			8.8			6.0				3.5	
28.0	12.0	7.5		12.2	7.7		8.8			5.8				3.2	
30.0	11.1	7.1		11.8	7.3		8.8	7.4		5.7				2.9	
32.0	10.3	6.7		11.1	6.9		8.8	7.1		5.5	6.5			2.6	5.4
34.0	9.6	6.4		10.2	6.6		8.8	6.8		5.3	6.2			2.2	5.0
36.0	8.9	6.1	4.5	8.8	6.3		8.3	6.5		5.2	5.9			1.9	4.7
38.0	7.6	5.8	4.3	7.5	6.0	4.4	7.8	6.2		5.0	5.6			1.6	4.4
40.0	6.5	5.5	4.2	6.3	5.7	4.2	6.7	6.0	4.5	4.8	5.4				4.1
42.0	5.5	5.3	4.0	5.3	5.5	4.1	5.6	5.7	4.4	4.6	5.1	4.4			3.9
44.0	4.5	5.0	3.9	4.4	5.3	4.0	4.7	5.5	4.3	4.3	4.9	4.2			3.6
46.0	3.7	4.8	3.8	3.5	5.0	3.9	3.9	5.3	4.1	3.9	4.6	4.0			3.4
48.0	2.9	4.6	3.7	2.8	4.8	3.7	3.1	5.1	4.0		4.3	3.8			3.2
50.0	2.2	4.2	3.6		4.2	3.7		4.5	3.9		4.1	3.6			3.0
54.0		2.7	3.4		2.7	3.5		3.0	3.7		3.1	3.2			2.3
58.0			2.6			2.7			3.1			2.9			
θ(°)	51~ 83	56~ 84.5	58~ 84.5	56~ 83	60~ 84.5	62~ 84.5	59~ 83	63~ 84.5	66~ 84.5	63~ 83	65~ 84.5	69~ 84.5	70~ 83	70~ 84.5	73~ 84.5
標準フック	35t											12.2t			
フック重量	950kg											440kg			
標準巻掛本数	2											1			

カウンタウエイト 47t、アウトリガ張出幅 8.0m

PS+ブーム+2.0m+3.5m油圧チルトジブ

単位:t

ブーム長さ(m) 作業半径 (m)	40.4			45.4			50.5			55.6			60.0		
	オフセット			オフセット			オフセット			オフセット			オフセット		
	0°	20°	40°	0°	20°	40°	0°	20°	40°	0°	20°	40°	0°	20°	40°
8.0	58.6														
9.0	58.6	58.6		52.9											
10.0	58.6	58.6	53.9	52.0	48.4		34.9								
11.0	58.6	57.7	52.9	50.7	47.2	45.0	33.7	30.3		28.3					
12.0	58.6	56.5	51.9	49.5	46.2	44.1	32.6	29.4	27.4	27.3	25.1		26.0		
14.0	44.5	45.6	46.5	45.0	44.4	42.5	30.6	27.8	26.1	25.5	23.6	22.4	24.3	22.5	21.4
16.0	34.9	35.9	36.6	35.4	36.4	37.1	28.9	26.4	24.9	23.9	22.2	21.2	22.8	21.3	20.3
18.0	28.1	28.9	29.5	28.6	29.4	30.0	27.4	25.2	23.9	22.5	21.1	20.1	21.5	20.2	19.3
20.0	23.0	23.7	24.1	23.5	24.2	24.6	24.3	24.1	22.9	21.3	20.0	19.2	20.4	19.2	18.4
22.0	19.1	19.6	20.0	19.5	20.1	20.5	20.3	20.9	21.3	20.2	19.1	18.4	19.4	18.3	17.6
24.0	15.9	16.4	16.7	16.4	16.8	17.2	17.1	17.6	17.9	17.8	18.2	17.6	18.0	17.5	16.9
26.0	13.3	13.7	14.0	13.8	14.2	14.4	14.5	14.9	15.2	15.2	15.6	15.9	15.3	15.7	16.0
28.0	11.1	11.5	11.7	11.6	12.0	12.2	12.3	12.7	12.9	13.0	13.3	13.6	13.1	13.5	13.8
30.0	9.0	9.4	9.5	9.6	10.0	10.2	10.5	10.8	11.0	11.1	11.5	11.7	11.3	11.6	11.8
32.0	7.2	7.5	7.6	7.8	8.1	8.3	8.7	9.0	9.2	9.4	9.8	10.0	9.6	10.0	10.2
34.0	5.6	5.9	6.0	6.2	6.5	6.7	7.1	7.4	7.6	7.9	8.2	8.4	8.0	8.4	8.6
36.0	4.3	4.5		4.9	5.1	5.2	5.7	6.0	6.2	6.5	6.8	7.0	6.6	7.0	7.1
38.0	3.1	3.2		3.7	3.9	3.9	4.5	4.8	4.9	5.3	5.6	5.7	5.4	5.7	5.9
40.0				2.6	2.8		3.5	3.7	3.8	4.2	4.4	4.6	4.3	4.6	4.7
42.0							2.5	2.7	2.7	3.2	3.5	3.5	3.4	3.6	3.7
44.0							1.7	1.8		2.4	2.6	2.6	2.5	2.7	2.8
46.0										1.6	1.8	1.8	1.7	1.9	2.0
θ(°)	32~ 84.5	33~ 84.5	43~ 84.5	37~ 84.5	38~ 84.5	42~ 84.5	38~ 84.5	38~ 84.5	42~ 84.5	41~ 84.5	42~ 84.5	42~ 84.5	46~ 84.5	47~ 84.5	48~ 84.5
標準フック	80t						35t								
フック重量	1550kg						950kg								
標準巻掛本数	5						3								

カウンタウエイト 47t、アウトリガ張出幅 8.0m

PS+ブーム+2.0m+11.5m油圧チルトジブ

単位:t

ブーム長さ(m) 作業半径 (m)	40.4			45.4			50.5			55.6			60.0		
	オフセット			オフセット			オフセット			オフセット			オフセット		
	0°	20°	40°	0°	20°	40°	0°	20°	40°	0°	20°	40°	0°	20°	40°
10.0	45.4														
11.0	45.4			36.6											
12.0	44.8			36.6			27.9								
14.0	42.2	32.1		36.6	30.8		25.8			22.3			19.5		
16.0	36.0	30.6	24.5	36.5	29.6		24.0	19.0		20.7	17.0		19.5		
18.0	29.2	29.3	23.9	29.6	28.4	24.2	22.5	18.0	15.5	19.3	16.0		18.4	15.4	
20.0	24.1	26.4	23.3	24.5	26.8	23.5	21.1	17.1	14.9	18.1	15.2	13.5	17.3	14.6	
22.0	20.1	22.1	22.8	20.5	22.5	22.8	19.9	16.4	14.3	17.0	14.4	12.9	16.3	13.9	12.4
24.0	17.0	18.7	20.1	17.3	19.1	20.5	17.7	15.7	13.8	16.1	13.7	12.4	15.4	13.2	11.9
26.0	14.4	15.9	17.1	14.7	16.2	17.5	15.1	15.0	13.4	15.2	13.1	11.9	14.6	12.6	11.4
28.0	12.2	13.6	14.6	12.5	13.9	15.0	12.9	14.3	12.9	13.4	12.6	11.4	13.3	12.1	11.0
30.0	10.3	11.6	12.5	10.7	11.9	12.9	11.1	12.3	12.5	11.6	12.0	11.0	11.5	11.6	10.6
32.0	8.5	9.9	10.7	8.9	10.2	11.1	9.4	10.6	11.5	10.0	11.1	10.6	9.8	11.0	10.3
34.0	7.0	8.2	9.1	7.3	8.6	9.5	7.8	9.1	9.9	8.4	9.6	10.3	8.3	9.5	9.9
36.0	5.6	6.7	7.5	6.0	7.1	8.0	6.5	7.6	8.5	7.0	8.2	9.0	6.9	8.1	9.0
38.0	4.4	5.4	6.0	4.8	5.8	6.5	5.3	6.3	7.1	5.8	6.9	7.7	5.7	6.8	7.7
40.0	3.4	4.2	4.7	3.7	4.7	5.3	4.2	5.2	5.8	4.7	5.7	6.4	4.6	5.7	6.4
42.0	2.4	3.2	3.5	2.8	3.6	4.1	3.2	4.1	4.7	3.8	4.7	5.3	3.7	4.6	5.3
44.0					2.7	3.1	2.4	3.2	3.7	2.9	3.8	4.3	2.8	3.7	4.3
46.0							1.6	2.3	2.8	2.1	2.9	3.4		2.8	3.4
48.0								1.6	1.9		2.1	2.5			2.5
50.0												1.8			
θ(°)	37~ 83	42~ 84.5	44~ 84.5	44~ 83	45~ 84.5	47~ 84.5	44~ 83	45~ 84.5	46~ 84.5	48~ 83	50~ 84.5	49~ 84.5	54~ 83	55~ 84.5	55~ 84.5
標準フック	80t						35t								
フック重量	1550kg						950kg								
標準巻掛本数	4						3								

PS+油圧チルトジブ

カウンタウエイト 47t、アウトリガ張出幅 8.0m

PS+ブーム+2.0m+17.5m油圧チルトジブ

単位:t

ブーム長さ(m) 作業半径 (m)	40.4			45.4			50.5			55.6			60.0		
	オフセット			オフセット			オフセット			オフセット			オフセット		
	0°	20°	40°	0°	20°	40°	0°	20°	40°	0°	20°	40°	0°	20°	40°
11.0	32.6														
12.0	32.6			28.2											
14.0	32.6			28.2			21.7								
16.0	31.2	21.3		28.2			21.0			16.9				14.4	
18.0	29.4	20.2		28.1	20.7		19.6	14.9		16.9				14.0	
20.0	25.0	19.2		25.1	19.8		18.3	14.1		15.9	12.7			13.6	
22.0	21.0	18.3	14.0	21.1	18.9		17.2	13.4		14.9	12.1			13.1	11.6
24.0	17.8	17.5	13.6	17.8	18.0	13.8	16.2	12.8	11.0	14.0	11.5			12.7	11.1
26.0	15.1	16.7	13.3	15.2	17.3	13.5	15.3	12.3	10.6	13.2	10.9	9.6		12.1	10.6
28.0	12.9	15.0	12.9	13.0	15.1	13.1	13.5	11.8	10.2	12.5	10.4	9.2		11.6	10.1
30.0	11.1	12.9	12.7	11.2	13.0	12.9	11.6	11.3	9.9	11.8	10.0	8.9		11.1	9.7
32.0	9.4	11.2	12.4	9.5	11.3	12.6	10.0	10.9	9.6	10.2	9.6	8.6		10.1	9.3
34.0	7.8	9.6	10.8	7.9	9.7	11.0	8.4	10.2	9.3	8.7	9.2	8.3		8.5	8.9
36.0	6.5	8.2	9.3	6.6	8.3	9.5	7.0	8.8	9.1	7.3	8.8	8.0		7.1	8.4
38.0	5.3	6.8	8.0	5.3	7.0	8.2	5.8	7.5	8.6	6.1	7.8	7.8		5.9	7.6
40.0	4.2	5.6	6.6	4.3	5.8	6.9	4.8	6.3	7.4	5.0	6.6	7.5		4.9	6.4
42.0	3.2	4.5	5.4	3.3	4.7	5.7	3.8	5.2	6.2	4.1	5.5	6.5		3.9	5.4
44.0	2.4	3.5	4.2	2.4	3.7	4.6	2.9	4.2	5.1	3.2	4.5	5.5		3.0	4.4
46.0		2.6	3.2	1.7	2.8	3.5	2.1	3.3	4.1	2.4	3.6	4.5		3.5	4.4
48.0					2.0	2.6		2.5	3.2		2.8	3.6			3.5
50.0						1.7			2.4			2.8			2.7
θ(°)	42~ 83	45~ 84.5	48~ 84.5	45~ 83	48~ 84.5	48~ 84.5	49~ 83	52~ 84.5	53~ 84.5	53~ 83	56~ 84.5	57~ 84.5	58~ 83	61~ 84.5	60~ 84.5
標準フック	35t						35t								
フック重量	950kg						950kg								
標準巻掛本数	3						2								

カウンタウエイト 47t、アウトリガ張出幅 8.0m

PS+ブーム+2.0m+23.5m油圧チルトジブ

単位:t

ブーム長さ(m) 作業半径 (m)	40.4			45.4			50.5			55.6			60.0		
	オフセット			オフセット			オフセット			オフセット			オフセット		
	0°	20°	40°	0°	20°	40°	0°	20°	40°	0°	20°	40°	0°	20°	40°
12.0	24.7														
14.0	24.7			21.4			16.6								
16.0	24.7			21.4			16.6			12.7					
18.0	24.3			21.4			16.6			12.7				10.4	
20.0	23.0	14.4		21.4			16.1			12.7				10.0	
22.0	21.7	13.6		21.1	14.0		15.1	11.3		12.7				9.6	
24.0	18.4	12.9		18.4	13.3		14.1	10.8		12.4	9.8			9.2	
26.0	15.8	12.3	9.3	15.8	12.7		13.3	10.3		11.7	9.4			8.8	9.0
28.0	13.6	11.7	9.0	13.6	12.1	9.1	12.6	9.9		11.0	8.9			8.3	8.6
30.0	11.7	11.2	8.7	11.7	11.6	8.9	11.9	9.5	8.1	10.4	8.5	7.4		7.9	8.2
32.0	10.1	10.7	8.5	10.1	11.2	8.6	10.3	9.1	7.8	9.9	8.1	7.1		7.4	7.7
34.0	8.5	10.3	8.3	8.5	10.7	8.4	8.7	7.6	8.9	7.8	6.9	7.0		7.3	6.2
36.0	7.2	9.3	8.1	7.1	9.3	8.2	7.4	8.4	7.3	7.5	6.6	6.6		6.8	5.9
38.0	5.9	8.0	7.9	5.9	8.1	8.1	6.1	8.1	7.1	6.3	7.2	6.4		6.1	5.7
40.0	4.8	6.8	7.7	4.8	6.8	7.9	5.1	7.1	6.9	5.2	6.9	6.2		5.0	6.1
42.0	3.9	5.6	7.0	3.9	5.7	7.2	4.1	5.9	6.7	4.3	6.1	6.0		4.1	5.8
44.0	3.0	4.6	5.8	3.0	4.7	6.0	3.2	4.9	6.3	3.4	5.1	5.8		5.0	4.9
46.0	2.2	3.7	4.8	2.2	3.8	5.0	2.4	4.0	5.3		4.2	5.5		4.1	4.7
48.0	1.5	2.8	3.8		2.9	4.0		3.2	4.3		3.4	4.6		3.3	4.5
50.0		2.0	2.8		2.1	3.1		2.4	3.4		2.6	3.7			3.6
θ(°)	43~ 83	47~ 84.5	52~ 84.5	50~ 83	53~ 84.5	57~ 84.5	54~ 83	56~ 84.5	61~ 84.5	59~ 83	60~ 84.5	64~ 84.5	62~ 83	64~ 84.5	66~ 84.5
標準フック	35t						35t								
フック重量	950kg						950kg								
標準巻掛本数	3						2								

カウンタウエイト 47t、アウトリガ張出幅 8.0m
PS+ブーム+2.0m+29.5m油圧チルトジブ

単位:t

ブーム長さ(m) 作業半径 (m)	40.4			45.4			50.5			55.6			60.0			
	オフセット			オフセット			オフセット			オフセット			オフセット			
	0°	20°	40°	0°	20°	40°	0°	20°	40°	0°	20°	40°	0°	20°	40°	
14.0	18.7			16.1												
16.0	18.7			16.1			12.4									
18.0	18.7			16.1			12.4			8.7				7.0		
20.0	18.7			16.1			12.4			8.7				6.7		
22.0	17.8			16.1			12.4			8.7				6.3		
24.0	16.5	10.2		16.1	10.5		12.4			8.7				6.0		
26.0	15.2	9.6		15.7	9.9		11.8	8.9		8.6				5.6		
28.0	13.9	9.1		13.8	9.4		11.1	8.5		8.4	8.0			5.3		
30.0	12.0	8.7		11.9	9.0		10.5	8.1		8.3	7.6			4.9	6.7	
32.0	10.4	8.3	6.2	10.3	8.6	6.3	10.0	7.8		8.1	7.3			4.6	6.3	
34.0	8.9	7.9	6.0	8.8	8.2	6.1	8.9	7.5	6.2	7.9	6.9			4.2	5.9	
36.0	7.5	7.6	5.9	7.4	7.9	6.0	7.5	7.2	6.0	7.7	6.6	5.8		3.9	5.5	
38.0	6.3	7.2	5.7	6.2	7.5	5.8	6.3	6.9	5.9	6.7	6.4	5.6	3.5	5.2	4.4	
40.0	5.2	6.9	5.5	5.1	7.2	5.6	5.2	6.6	5.7	5.6	6.1	5.4	3.2	4.9	4.2	
42.0	4.2	6.4	5.4	4.1	6.4	5.5	4.3	6.4	5.6	4.6	5.8	5.2	2.9	4.6	4.0	
44.0	3.3	5.4	5.3	3.2	5.4	5.4	3.4	5.5	5.4	3.8	5.6	5.0		4.3	3.8	
46.0	2.5	4.4	5.1		4.4	5.2		4.6	5.2		5.0	4.8		4.1	3.6	
48.0		3.6	5.0		3.6	5.1		3.7	5.1		4.1	4.6		3.9	3.4	
50.0		2.8	4.1		2.8	4.2		3.0	4.4		3.4	4.4			3.3	
54.0			2.4			2.5			2.8			3.2				
θ(°)	51~ 83	55~ 84.5	55~ 84.5	56~ 83	58~ 84.5	60~ 84.5	59~ 83	61~ 84.5	63~ 84.5	62~ 83	64~ 84.5	66~ 84.5	65~ 83	68~ 84.5	72~ 84.5	
標準フック							35t							12.2t		
フック重量							950kg							440kg		
標準巻掛本数							2							1		

PS+油圧チルトジブ

カウンタウエイト 47t、アウトリガ張出幅 6.8m

PS+ブーム+2.0m+3.5m油圧チルトジブ

単位:t

ブーム長さ(m) 作業半径 (m)	40.4			45.4			50.5			55.6			60.0		
	オフセット			オフセット			オフセット			オフセット			オフセット		
	0°	20°	40°	0°	20°	40°	0°	20°	40°	0°	20°	40°	0°	20°	40°
8.0	58.6														
9.0	58.6	58.6		52.9											
10.0	58.6	58.6	53.9	52.0	48.4		34.9								
11.0	55.7	57.3	52.9	50.7	47.2	45.0	33.7	30.3		28.3					
12.0	47.7	49.1	50.2	48.2	46.2	44.1	32.6	29.4	27.4	27.3	25.1		26.0		
14.0	36.3	37.4	38.3	36.8	37.9	38.7	30.6	27.8	26.1	25.5	23.6	22.4	24.3	22.5	21.4
16.0	28.6	29.5	30.1	29.0	29.9	30.6	28.9	26.4	24.9	23.9	22.2	21.2	22.8	21.3	20.3
18.0	22.9	23.7	24.2	23.4	24.1	24.6	24.2	24.9	23.9	22.5	21.1	20.1	21.5	20.2	19.3
20.0	18.6	19.3	19.7	19.1	19.7	20.2	19.9	20.5	20.9	20.5	20.0	19.2	20.4	19.2	18.4
22.0	15.3	15.8	16.1	15.7	16.3	16.6	16.5	17.0	17.4	17.1	17.6	18.0	17.3	17.8	17.6
24.0	12.6	13.0	13.3	13.0	13.5	13.8	13.7	14.2	14.5	14.4	14.8	15.2	14.5	15.0	15.3
26.0	10.1	10.7	10.9	10.7	11.2	11.4	11.5	11.9	12.2	12.1	12.5	12.8	12.3	12.7	13.0
28.0	8.0	8.4	8.7	8.6	9.0	9.3	9.5	9.9	10.2	10.2	10.6	10.8	10.4	10.8	11.0
30.0	6.2	6.6	6.7	6.8	7.2	7.4	7.7	8.1	8.3	8.4	8.8	9.1	8.6	9.0	9.3
32.0	4.6	5.0	5.1	5.2	5.6	5.7	6.1	6.4	6.7	6.9	7.2	7.4	7.0	7.4	7.6
34.0	3.3	3.5	3.6	3.9	4.2	4.3	4.7	5.0	5.2	5.5	5.8	6.0	5.6	6.0	6.2
36.0				2.7	2.9	3.0	3.5	3.8	3.9	4.3	4.6	4.7	4.4	4.7	4.9
38.0							2.5	2.7	2.8	3.2	3.5	3.6	3.4	3.6	3.8
40.0								1.7	1.8	2.3	2.5	2.6	2.4	2.7	2.8
θ(°)	41~ 84.5	42~ 84.5	43~ 84.5	45~ 84.5	46~ 84.5	46~ 84.5	47~ 84.5	45~ 84.5	46~ 84.5	50~ 84.5	51~ 84.5	51~ 84.5	53~ 84.5	54~ 84.5	55~ 84.5
標準フック	80t						35t								
フック重量	1550kg						950kg								
標準巻掛本数	5						3								

カウンタウエイト 47t、アウトリガ張出幅 6.8m

PS+ブーム+2.0m+11.5m油圧チルトジブ

単位:t

ブーム長さ(m) 作業半径 (m)	40.4			45.4			50.5			55.6			60.0		
	オフセット			オフセット			オフセット			オフセット			オフセット		
	0°	20°	40°	0°	20°	40°	0°	20°	40°	0°	20°	40°	0°	20°	40°
10.0	45.4														
11.0	45.4			36.6											
12.0	44.8			36.6			27.9								
14.0	37.3	32.1		36.6	30.8		25.8			22.3			19.5		
16.0	29.6	30.6	24.5	29.9	29.6		24.0	19.0		20.7	17.0		19.5		
18.0	23.9	26.5	23.9	24.3	26.8	24.2	22.5	18.0	15.5	19.3	16.0		18.4	15.4	
20.0	19.6	21.8	23.3	20.0	22.2	23.5	20.4	17.1	14.9	18.1	15.2	13.5	17.3	14.6	
22.0	16.3	18.2	19.8	16.6	18.5	20.1	17.0	16.4	14.3	17.0	14.4	12.9	16.3	13.9	12.4
24.0	13.5	15.2	16.6	13.9	15.6	17.0	14.3	15.7	13.8	14.8	13.7	12.4	14.7	13.2	11.9
26.0	11.3	12.8	14.0	11.6	13.2	14.4	12.0	13.5	13.4	12.5	13.1	11.9	12.4	12.6	11.4
28.0	9.3	10.8	11.8	9.6	11.1	12.2	10.1	11.5	12.6	10.6	12.0	11.4	10.5	11.9	11.0
30.0	7.5	9.0	10.0	7.9	9.4	10.3	8.3	9.8	10.7	8.9	10.2	11.0	8.8	10.2	10.6
32.0	5.9	7.3	8.3	6.3	7.7	8.7	6.8	8.2	9.1	7.3	8.7	9.6	7.2	8.6	9.6
34.0	4.6	5.8	6.6	4.9	6.2	7.1	5.4	6.7	7.6	6.0	7.2	8.2	5.9	7.2	8.1
36.0	3.4	4.5	5.2	3.7	4.9	5.7	4.2	5.4	6.2	4.8	5.9	6.8	4.7	5.9	6.8
38.0		3.3	3.9	2.7	3.7	4.4	3.2	4.2	5.0	3.7	4.8	5.6	3.6	4.7	5.5
40.0				2.7		3.3	2.2	3.2	3.9	2.8	3.8	4.5		3.7	4.4
42.0								2.3	2.8		2.8	3.4			3.4
44.0												2.5			
θ(°)	48~ 83	49~ 84.5	48~ 83	50~ 84.5	51~ 84.5	53~ 84.5	51~ 83	53~ 84.5	55~ 84.5	55~ 83	57~ 84.5	56~ 84.5	60~ 83	61~ 84.5	62~ 84.5
標準フック	80t						35t								
フック重量	1550kg						950kg								
標準巻掛本数	4						3								

カウンタウエイト 47t、アウトリガ張出幅 6.8m

PS+ブーム+2.0m+17.5m油圧チルトジブ

単位:t

ブーム長さ(m) 作業半径 (m)	40.4			45.4			50.5			55.6			60.0		
	オフセット			オフセット			オフセット			オフセット			オフセット		
	0°	20°	40°	0°	20°	40°	0°	20°	40°	0°	20°	40°	0°	20°	40°
11.0	32.6														
12.0	32.6			28.2											
14.0	32.6			28.2			21.7								
16.0	30.5	21.3		28.2			21.0			16.9			14.4		
18.0	24.8	20.2		24.9	20.7		19.6	14.9		16.9			14.0		
20.0	20.4	19.2		20.5	19.8		18.3	14.1		15.9	12.7		13.6		
22.0	17.0	18.3	14.0	17.1	18.9		17.2	13.4		14.9	12.1		13.1	11.6	
24.0	14.3	16.8	13.6	14.4	16.9	13.8	14.8	12.8	11.0	14.0	11.5		12.7	11.1	
26.0	12.1	14.3	13.3	12.1	14.4	13.5	12.6	12.3	10.6	12.8	10.9	9.6	12.1	10.6	9.3
28.0	10.1	12.2	12.9	10.2	12.3	13.1	10.7	11.8	10.2	10.9	10.4	9.2	10.7	10.1	8.9
30.0	8.3	10.4	11.8	8.4	10.5	12.0	8.9	10.9	9.9	9.2	10.0	8.9	9.0	9.7	8.6
32.0	6.8	8.8	10.1	6.9	8.9	10.3	7.3	9.3	9.6	7.6	9.5	8.6	7.4	9.3	8.3
34.0	5.4	7.3	8.6	5.5	7.4	8.8	6.0	7.9	9.2	6.3	8.1	8.3	6.1	8.0	8.0
36.0	4.2	5.9	7.2	4.3	6.0	7.4	4.8	6.5	7.9	5.1	6.8	8.0	4.9	6.7	7.6
38.0	3.1	4.7	5.8	3.2	4.8	6.1	3.7	5.3	6.6	4.0	5.6	6.9	3.8	5.5	6.8
40.0		3.6	4.6		3.8	4.9	2.8	4.3	5.4	3.0	4.6	5.7		4.4	5.6
42.0		2.6	3.5		2.8	3.8		3.3	4.3		3.6	4.6		3.5	4.6
44.0					2.8				3.3			3.7			3.6
46.0												2.8			
θ(°)	51~ 83	51~ 84.5	55~ 84.5	55~ 83	56~ 84.5	57~ 84.5	56~ 83	59~ 84.5	60~ 84.5	59~ 83	62~ 84.5	62~ 84.5	63~ 83	64~ 84.5	66~ 84.5
標準フック	35t						35t								
フック重量	950kg						950kg								
標準巻掛本数	3						2								

カウンタウエイト 47t、アウトリガ張出幅 6.8m

PS+ブーム+2.0m+23.5m油圧チルトジブ

単位:t

ブーム長さ(m) 作業半径 (m)	40.4			45.4			50.5			55.6			60.0		
	オフセット			オフセット			オフセット			オフセット			オフセット		
	0°	20°	40°	0°	20°	40°	0°	20°	40°	0°	20°	40°	0°	20°	40°
12.0	24.7														
14.0	24.7			21.4			16.6								
16.0	24.7			21.4			16.6			12.7					
18.0	24.3			21.4			16.6			12.7			10.4		
20.0	21.1	14.4		21.1			16.1			12.7			10.0		
22.0	17.7	13.6		17.7	14.0		15.1	11.3		12.7			9.6		
24.0	14.9	12.9		14.9	13.3		14.1	10.8		12.4	9.8		9.2		
26.0	12.7	12.3	9.3	12.7	12.7		12.8	10.3		11.7	9.4		8.8	9.0	
28.0	10.8	11.7	9.0	10.8	12.1	9.1	10.9	9.9		11.0	8.9		8.3	8.6	
30.0	9.0	11.2	8.7	9.0	11.5	8.9	9.2	9.5	8.1	9.4	8.5	7.4	7.9	8.2	
32.0	7.4	9.9	8.5	7.4	9.9	8.6	7.6	9.1	7.8	7.8	8.1	7.1	7.4	7.7	6.5
34.0	6.1	8.5	8.3	6.1	8.5	8.4	6.3	8.7	7.6	6.5	7.8	6.9	6.2	7.3	6.2
36.0	4.9	7.1	8.1	4.9	7.1	8.2	5.1	7.4	7.3	5.3	7.5	6.6	5.0	6.8	5.9
38.0	3.8	5.9	7.5	3.8	5.9	7.6	4.0	6.1	7.1	4.2	6.3	6.4		6.2	5.7
40.0	2.8	4.7	6.3	2.8	4.8	6.4		5.0	6.6		5.2	6.2		5.1	5.4
42.0		3.7	5.1		3.8	5.2		4.0	5.5		4.2	5.7		4.1	5.1
44.0		2.8	4.0		2.9	4.2		3.1	4.5		3.3	4.7			4.6
46.0			3.1			3.2			3.6			3.8			
48.0			2.1												
θ(°)	53~ 83	55~ 84.5	55~ 84.5	57~ 83	59~ 84.5	62~ 84.5	61~ 83	62~ 84.5	65~ 84.5	64~ 83	65~ 84.5	68~ 84.5	67~ 83	69~ 84.5	72~ 84.5
標準フック	35t						35t								
フック重量	950kg						950kg								
標準巻掛本数	3						2								

PS+油圧チルトジブ

カウンタウエイト 25t、アウトリガ張出幅 8.5m

PS+ブーム+2.0m+3.5m油圧チルトジブ

単位:t

ブーム長さ(m) 作業半径 (m)	40.4			45.4			50.5			55.6			60.0		
	オフセット			オフセット			オフセット			オフセット			オフセット		
	0°	20°	40°	0°	20°	40°	0°	20°	40°	0°	20°	40°	0°	20°	40°
8.0	58.6														
9.0	58.6	58.6		52.9											
10.0	58.6	58.6	53.9	52.0	48.4		34.9								
11.0	53.4	55.1	52.9	50.7	47.2	45.0	33.7	30.3		28.3					
12.0	45.2	46.8	48.0	45.8	46.2	44.1	32.6	29.4	27.4	27.3	25.1		26.0		
14.0	33.4	34.5	35.4	33.9	35.1	35.9	30.6	27.8	26.1	25.5	23.6	22.4	24.3	22.5	21.4
16.0	25.5	26.5	27.2	26.0	27.0	27.7	26.9	26.4	24.9	23.9	22.2	21.2	22.8	21.3	20.3
18.0	20.0	20.8	21.3	20.5	21.2	21.8	21.3	22.1	22.6	22.0	21.1	20.1	21.5	20.2	19.3
20.0	15.8	16.5	16.9	16.3	17.0	17.4	17.1	17.8	18.2	17.8	18.5	18.9	18.0	18.6	18.4
22.0	12.6	13.2	13.5	13.1	13.7	14.0	13.9	14.4	14.8	14.6	15.1	15.5	14.7	15.3	15.7
24.0	10.0	10.5	10.8	10.5	11.0	11.3	11.3	11.8	12.1	12.0	12.4	12.8	12.1	12.6	13.0
26.0	7.6	8.1	8.4	8.2	8.7	9.0	9.1	9.6	9.9	9.8	10.3	10.5	10.0	10.4	10.7
28.0	5.6	6.1	6.3	6.2	6.7	6.9	7.1	7.6	7.9	7.9	8.4	8.7	8.1	8.5	8.9
30.0	3.9	4.3	4.5	4.5	4.9	5.1	5.4	5.8	6.1	6.2	6.6	6.9	6.4	6.8	7.1
32.0		2.8	2.9		3.4	3.6	4.0	4.3	4.6	4.8	5.1	5.4	4.9	5.3	5.5
34.0								3.0	3.2	3.5	3.8	4.0	3.6	4.0	4.2
θ(°)	49~ 84.5	46~ 84.5	47~ 84.5	54~ 84.5	52~ 84.5	53~ 84.5	56~ 84.5	54~ 84.5	55~ 84.5	57~ 84.5	58~ 84.5	58~ 84.5	60~ 84.5	61~ 84.5	62~ 84.5
標準フック	80t						35t								
フック重量	1550kg						950kg								
標準巻掛本数	5						3								

カウンタウエイト 25t、アウトリガ張出幅 8.5m

PS+ブーム+2.0m+11.5m油圧チルトジブ

単位:t

ブーム長さ(m) 作業半径 (m)	40.4			45.4			50.5			55.6			60.0		
	オフセット			オフセット			オフセット			オフセット			オフセット		
	0°	20°	40°	0°	20°	40°	0°	20°	40°	0°	20°	40°	0°	20°	40°
10.0	45.4														
11.0	45.4			36.6											
12.0	44.8			36.6			27.9								
14.0	34.5	32.1		35.0	30.8		25.8			22.3			19.5		
16.0	26.7	29.9	24.5	27.1	29.6		24.0	19.0		20.7	17.0		19.5		
18.0	21.1	23.8	23.9	21.5	24.2	24.2	21.9	18.0	15.5	19.3	16.0		18.4	15.4	
20.0	16.9	19.2	21.2	17.3	19.6	21.5	17.7	17.1	14.9	18.1	15.2	13.5	17.3	14.6	
22.0	13.7	15.7	17.4	14.1	16.1	17.7	14.5	16.4	14.3	15.0	14.4	12.9	14.9	13.9	12.4
24.0	11.1	12.9	14.3	11.5	13.3	14.7	11.9	13.6	13.8	12.4	13.7	12.4	12.3	13.2	11.9
26.0	8.9	10.6	11.8	9.3	10.9	12.2	9.8	11.3	12.6	10.3	11.8	11.9	10.2	11.7	11.4
28.0	6.9	8.7	9.8	7.3	9.0	10.1	7.8	9.4	10.5	8.4	9.9	11.0	8.3	9.8	11.0
30.0	5.3	6.8	8.0	5.6	7.2	8.4	6.1	7.7	8.8	6.7	8.3	9.3	6.6	8.2	9.2
32.0	3.8	5.2	6.2	4.2	5.6	6.7	4.7	6.1	7.2	5.3	6.7	7.8	5.2	6.6	7.7
34.0		3.8	4.7		4.3	5.2	3.5	4.7	5.7	4.0	5.3	6.3		5.2	6.2
36.0			3.4			3.9		3.5	4.4		4.1	5.0			4.9
38.0									3.2			3.8			
θ(°)	53~ 83	55~ 84.5	55~ 84.5	57~ 83	59~ 84.5	59~ 84.5	58~ 83	60~ 84.5	60~ 84.5	61~ 83	63~ 84.5	63~ 84.5	65~ 83	67~ 84.5	68~ 84.5
標準フック	80t						35t								
フック重量	1550kg						950kg								
標準巻掛本数	4						3								

カウンタウエイト 25t、アウトリガ張出幅 8.5m
PS+ブーム+2.0m+17.5m油圧チルトジブ

単位:t

ブーム長さ(m) 作業半径 (m)	40.4			45.4			50.5			55.6			60.0		
	オフセット			オフセット			オフセット			オフセット			オフセット		
	0°	20°	40°	0°	20°	40°	0°	20°	40°	0°	20°	40°	0°	20°	40°
11.0	32.6														
12.0	32.6			28.2											
14.0	32.6			28.2			21.7								
16.0	27.7	21.3		27.8			21.0			16.9			14.4		
18.0	22.0	20.2		22.1	20.7		19.6	14.9		16.9			14.0		
20.0	17.8	19.2		17.9	19.8		18.3	14.1		15.9	12.7		13.6		
22.0	14.6	17.5	14.0	14.6	17.6		15.1	13.4		14.9	12.1		13.1	11.6	
24.0	12.0	14.5	13.6	12.0	14.6	13.8	12.5	12.8	11.0	12.7	11.5		12.6	11.1	
26.0	9.8	12.1	13.3	9.9	12.2	13.5	10.4	12.3	10.6	10.6	10.9	9.6	10.4	10.6	9.3
28.0	7.9	10.1	11.9	7.9	10.2	12.0	8.5	10.6	10.2	8.8	10.4	9.2	8.6	10.1	8.9
30.0	6.2	8.4	10.0	6.2	8.5	10.1	6.8	8.9	9.9	7.0	9.2	8.9	6.9	9.1	8.6
32.0	4.7	6.8	8.3	4.8	6.9	8.5	5.3	7.4	8.9	5.6	7.7	8.6	5.4	7.6	8.3
34.0		5.4	6.9	3.6	5.5	7.1	4.0	6.0	7.5	4.3	6.3	7.7		6.1	7.7
36.0		4.1	5.4		4.2	5.6		4.7	6.1		5.0	6.4		4.9	6.4
38.0			4.1			4.4		3.6	4.9			5.2			5.1
40.0						3.2			3.8			4.1			
θ (°)	58~ 83	59~ 84.5	61~ 84.5	59~ 83	62~ 84.5	62~ 84.5	62~ 83	63~ 84.5	65~ 84.5	64~ 83	68~ 84.5	68~ 84.5	68~ 83	69~ 84.5	71~ 84.5
標準フック	35t						35t								
フック重量	950kg						950kg								
標準巻掛本数	3						2								

PS+油圧チルトジブ

カウンタウエイト 25t、アウトリガ張出幅 8.0m

PS+ブーム+2.0m+3.5m油圧チルトジブ

単位:t

ブーム長さ(m) 作業半径 (m)	40.4			45.4			50.5			55.6			60.0		
	オフセット			オフセット			オフセット			オフセット			オフセット		
	0°	20°	40°	0°	20°	40°	0°	20°	40°	0°	20°	40°	0°	20°	40°
8.0	58.6														
9.0	58.6	58.6		52.9											
10.0	58.6	58.6	53.9	52.0	48.4		34.9								
11.0	48.9	50.7	52.0	49.5	47.2	45.0	33.7	30.3		28.3					
12.0	41.2	42.7	43.9	41.8	43.3	44.1	32.6	29.4	27.4	27.3	25.1		26.0		
14.0	30.5	31.6	32.5	31.0	32.1	33.0	30.6	27.8	26.1	25.5	23.6	22.4	24.3	22.5	21.4
16.0	23.3	24.2	24.9	23.8	24.7	25.4	24.6	25.5	24.9	23.9	22.2	21.2	22.8	21.3	20.3
18.0	18.1	18.9	19.5	18.6	19.4	19.9	19.4	20.2	20.7	20.2	20.9	20.1	20.4	20.2	19.3
20.0	14.3	14.9	15.4	14.8	15.4	15.9	15.6	16.2	16.7	16.3	16.9	17.3	16.4	17.1	17.5
22.0	11.3	11.9	12.2	11.8	12.3	12.7	12.5	13.1	13.5	13.2	13.8	14.1	13.4	13.9	14.3
24.0	8.7	9.3	9.6	9.2	9.8	10.2	10.1	10.6	10.9	10.8	11.3	11.6	10.9	11.4	11.8
26.0	6.4	6.9	7.2	7.0	7.5	7.8	7.9	8.4	8.8	8.7	9.2	9.5	8.9	9.4	9.7
28.0	4.6	5.0	5.2	5.1	5.6	5.9	6.0	6.5	6.8	6.8	7.3	7.6	7.0	7.5	7.8
30.0		3.4	3.5		4.0	4.2	4.5	4.9	5.1	5.2	5.7	5.9	5.4	5.8	6.1
32.0								3.5	3.7	3.9	4.2	4.5	4.0	4.4	4.6
θ(°)	52~ 84.5	50~ 84.5	50~ 84.5	57~ 84.5	55~ 84.5	56~ 84.5	58~ 84.5	57~ 84.5	57~ 84.5	59~ 84.5	60~ 84.5	61~ 84.5	62~ 84.5	63~ 84.5	64~ 84.5
標準フック	80t						35t								
フック重量	1550kg						950kg								
標準巻掛本数	5						3								

カウンタウエイト 25t、アウトリガ張出幅 8.0m

PS+ブーム+2.0m+11.5m油圧チルトジブ

単位:t

ブーム長さ(m) 作業半径 (m)	40.4			45.4			50.5			55.6			60.0		
	オフセット			オフセット			オフセット			オフセット			オフセット		
	0°	20°	40°	0°	20°	40°	0°	20°	40°	0°	20°	40°	0°	20°	40°
10.0	45.4														
11.0	45.4			36.6											
12.0	42.4			36.6			27.9								
14.0	31.6	32.1		32.0	30.8		25.8			22.3			19.5		
16.0	24.4	27.5	24.5	24.8	27.9		24.0	19.0		20.7	17.0		19.5		
18.0	19.2	21.9	23.9	19.6	22.2	24.2	20.0	18.0	15.5	19.3	16.0		18.4	15.4	
20.0	15.4	17.6	19.5	15.7	18.0	19.9	16.2	17.1	14.9	16.7	15.2	13.5	16.6	14.6	
22.0	12.4	14.3	16.0	12.7	14.7	16.3	13.1	15.1	14.3	13.7	14.4	12.9	13.6	13.9	12.4
24.0	9.9	11.7	13.1	10.3	12.0	13.5	10.7	12.4	13.8	11.2	12.9	12.4	11.1	12.8	11.9
26.0	7.7	9.5	10.8	8.1	9.9	11.1	8.6	10.3	11.5	9.2	10.7	11.9	9.1	10.7	11.4
28.0	5.9	7.6	8.8	6.2	8.0	9.2	6.7	8.4	9.5	7.3	8.9	10.0	7.2	8.9	10.0
30.0	4.3	5.8	7.0	4.7	6.2	7.4	5.2	6.7	7.9	5.7	7.3	8.4	5.6	7.2	8.3
32.0		4.3	5.3		4.7	5.8	3.8	5.2	6.3	4.4	5.8	6.8		5.7	6.8
34.0			3.9			4.3		3.9	4.9		4.5	5.4			5.4
36.0								3.6			4.2				
θ(°)	56~ 83	58~ 84.5	58~ 84.5	60~ 83	61~ 84.5	62~ 84.5	60~ 83	62~ 84.5	62~ 84.5	63~ 83	65~ 84.5	65~ 84.5	67~ 83	69~ 84.5	70~ 84.5
標準フック	80t						35t								
フック重量	1550kg						950kg								
標準巻掛本数	4						3								

カウンタウエイト 25t、アウトリガ張出幅 8.0m
 PS+ブーム+2.0m+17.5m油圧チルトジブ

単位:t

ブーム長さ(m) 作業半径 (m)	40.4			45.4			50.5			55.6			60.0		
	オフセット			オフセット			オフセット			オフセット			オフセット		
	0°	20°	40°	0°	20°	40°	0°	20°	40°	0°	20°	40°	0°	20°	40°
11.0	32.6														
12.0	32.6			28.2											
14.0	32.6			28.2			21.7								
16.0	25.4	21.3		25.5			21.0			16.9			14.4		
18.0	20.2	20.2		20.2	20.7		19.6	14.9		16.9			14.0		
20.0	16.2	19.2		16.3	19.6		16.8	14.1		15.9	12.7		13.6		
22.0	13.2	16.1	14.0	13.3	16.2		13.7	13.4		14.0	12.1		13.1	11.6	
24.0	10.8	13.3	13.6	10.8	13.4	13.8	11.3	12.8	11.0	11.5	11.5		11.4	11.1	
26.0	8.7	11.0	13.0	8.7	11.1	13.1	9.3	11.5	10.6	9.5	10.9	9.6	9.4	10.6	9.3
28.0	6.8	9.1	10.9	6.9	9.2	11.0	7.4	9.7	10.2	7.7	9.9	9.2	7.5	9.8	8.9
30.0	5.2	7.5	9.1	5.3	7.6	9.2	5.8	8.0	9.6	6.1	8.3	8.9	5.9	8.2	8.6
32.0		5.9	7.5	3.9	6.0	7.7	4.4	6.5	8.1		6.8	8.3		6.6	8.2
34.0		4.5	6.0		4.6	6.2		5.1	6.7		5.4	7.0		5.3	6.9
36.0			4.6			4.8		3.9	5.3			5.6			5.5
38.0						3.6			4.1			4.4			
θ (°)	60~ 83	62~ 84.5	63~ 84.5	61~ 83	65~ 84.5	64~ 84.5	64~ 83	65~ 84.5	67~ 84.5	68~ 83	69~ 84.5	69~ 84.5	70~ 83	71~ 84.5	73~ 84.5
標準フック	35t						35t								
フック重量	950kg						950kg								
標準巻掛本数	3						2								

PS+油圧チルトジブ

カウンタウエイト 25t、アウトリガ張出幅 6.8m

PS+ブーム+2.0m+3.5m油圧チルトジブ

単位:t

ブーム長さ(m) 作業半径 (m)	40.4			45.4			50.5			55.6			60.0			
	オフセット			オフセット			オフセット			オフセット			オフセット			
	0°	20°	40°	0°	20°	40°	0°	20°	40°	0°	20°	40°	0°	20°	40°	
8.0	58.6															
9.0	56.9	58.6		52.9												
10.0	46.3	48.2	49.6	46.9	48.4		34.9									
11.0	38.6	40.2	41.4	39.1	40.6	41.9	33.7	30.3		28.3						
12.0	32.6	34.0	35.1	33.1	34.5	35.5	32.6	29.4	27.4	27.3	25.1		26.0			
14.0	24.1	25.2	26.0	24.6	25.6	26.4	25.4	26.4	26.1	25.5	23.6	22.4	24.3	22.5	21.4	
16.0	18.2	19.1	19.8	18.7	19.6	20.2	19.5	20.4	21.0	20.3	21.1	21.2	20.4	21.3	20.3	
18.0	14.0	14.7	15.3	14.5	15.2	15.7	15.3	16.0	16.5	16.0	16.7	17.2	16.1	16.8	17.4	
20.0	10.8	11.4	11.8	11.2	11.9	12.3	12.0	12.6	13.1	12.7	13.3	13.7	12.9	13.5	13.9	
22.0	7.9	8.6	9.1	8.5	9.2	9.6	9.4	10.0	10.4	10.1	10.7	11.0	10.3	10.8	11.2	
24.0	5.6	6.2	6.6	6.2	6.8	7.2	7.1	7.7	8.1	7.9	8.5	8.8	8.1	8.6	9.0	
26.0		4.2	4.5		4.8	5.1	5.2	5.7	6.0	6.0	6.5	6.8	6.1	6.6	7.0	
28.0								4.0	4.3		4.8	5.1		5.0	5.3	
θ(°)	58~ 84.5	57~ 84.5	57~ 84.5	62~ 84.5	61~ 84.5	62~ 84.5	63~ 84.5	62~ 84.5	62~ 84.5	62~ 84.5	66~ 84.5	65~ 84.5	65~ 84.5	68~ 84.5	67~ 84.5	68~ 84.5
標準フック	80t						35t									
フック重量	1550kg						950kg									
標準巻掛本数	5						3									

カウンタウエイト 25t、アウトリガ張出幅 6.8m

PS+ブーム+2.0m+11.5m油圧チルトジブ

単位:t

ブーム長さ(m) 作業半径 (m)	40.4			45.4			50.5			55.6			60.0			
	オフセット			オフセット			オフセット			オフセット			オフセット			
	0°	20°	40°	0°	20°	40°	0°	20°	40°	0°	20°	40°	0°	20°	40°	
10.0	45.4															
11.0	39.6			36.6												
12.0	33.6			34.1			27.9									
14.0	25.1	28.7		25.5	29.0		25.8			22.3			19.5			
16.0	19.2	22.2	24.5	19.6	22.6		20.1	19.0		20.6	17.0		19.5			
18.0	15.0	17.5	19.7	15.4	17.9	20.0	15.8	18.0	15.5	16.3	16.0		16.2	15.4		
20.0	11.8	14.0	15.8	12.1	14.3	16.2	12.5	14.7	14.9	13.1	15.2	13.5	13.0	14.6		
22.0	9.2	11.2	12.8	9.6	11.5	13.1	10.0	11.9	13.4	10.5	12.4	12.9	10.4	12.3	12.4	
24.0	6.9	8.9	10.3	7.2	9.3	10.6	7.7	9.6	11.0	8.3	10.1	11.4	8.2	10.0	11.4	
26.0	5.0	6.8	8.3		7.2	8.6	5.8	7.7	9.0	6.4	8.2	9.4	6.3	8.1	9.4	
28.0		5.0	6.3		5.4	6.8		5.9	7.2		6.5	7.7		6.4	7.7	
30.0			4.7			5.1			5.6		4.9	6.1			6.1	
32.0											4.7					
θ(°)	61~ 83	63~ 84.5	64~ 84.5	66~ 83	66~ 84.5	67~ 84.5	66~ 83	68~ 84.5	69~ 84.5	69~ 83	69~ 84.5	69~ 84.5	70~ 83	72~ 84.5	73~ 84.5	
標準フック	80t						35t									
フック重量	1550kg						950kg									
標準巻掛本数	4						3									

ラフィングジブ

■ ラフィングジブ(LJ)の構成

2.5m+20.3mジブ

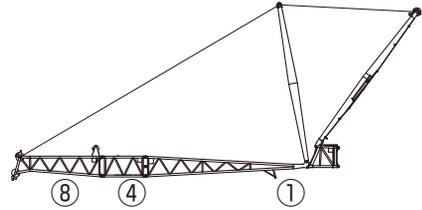

2.5m+32.3mジブ

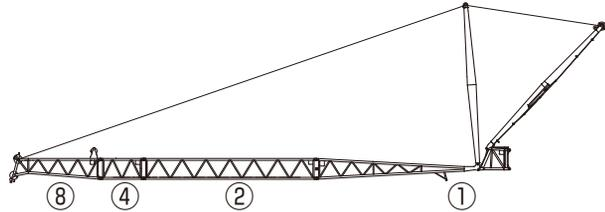

2.5m+34mジブ

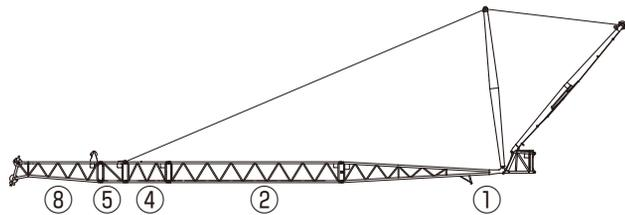

2.5m+40mジブ

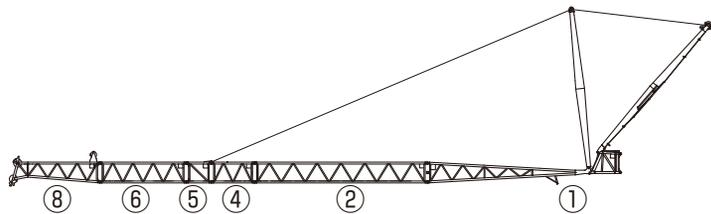

2.5m+46mジブ(ヘビー)

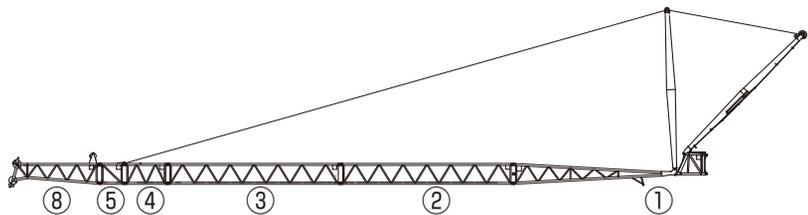

2.5m+52mジブ(ヘビー)

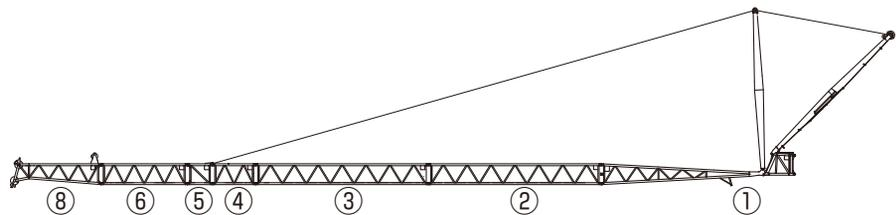

2.5m+58mジブ(ヘビー)

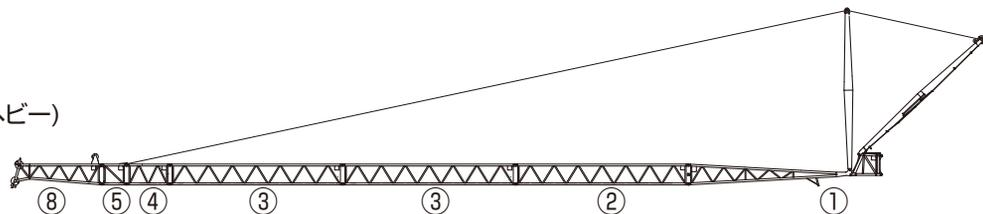

2.5m+64mジブ(ヘビー)

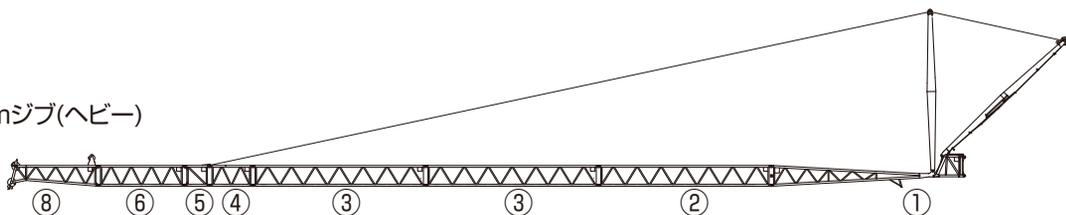

記号	名称	長さ
①	ベースジブ	11.3 m
②	ミドルAジブ	12.0 m
③	ミドルBジブ	12.0 m
④	レデューサジブ	3.0 m
⑤	ペンダントコネクタジブ	1.7 m
⑥	ミドルCジブ	6.0 m
⑦	ミドルDジブ	12.0 m
⑧	トップジブ	6.0 m

2.5m+70mジブ

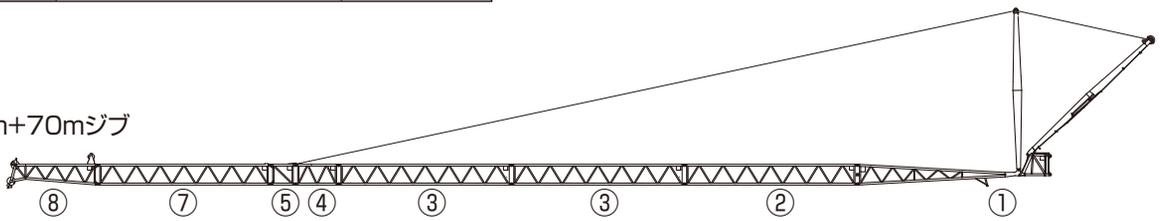

2.5m+76mジブ

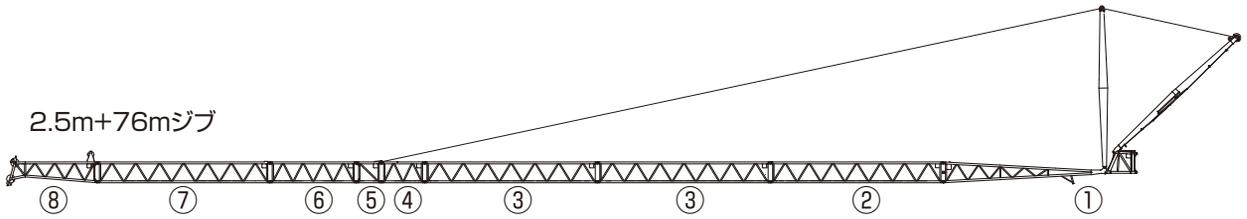

2.5m+46mジブ(ライト)

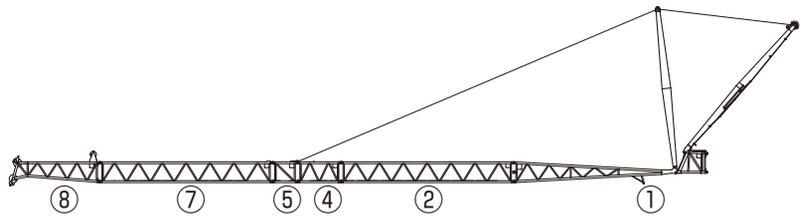

2.5m+52mジブ(ライト)

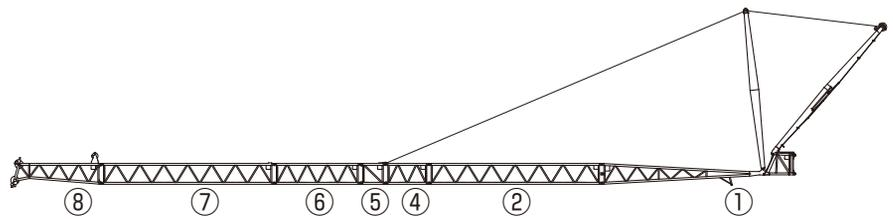

2.5m+58mジブ(ライト)

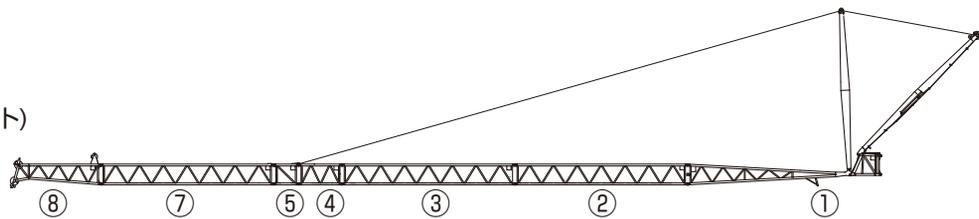

2.5m+64mジブ(ライト)

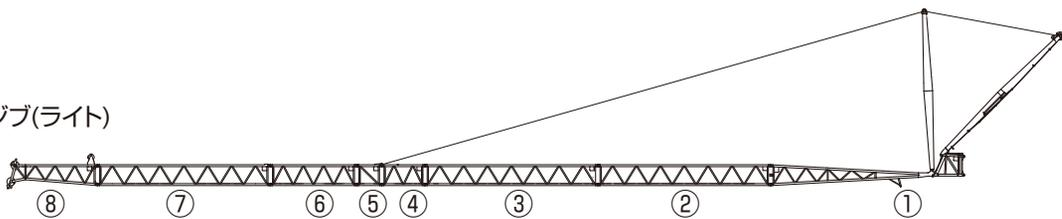

3

ラフィングジブ

ブーム+ラフィングジブ(LJ)作業半径-揚程図

ブーム+ラフィングジブ

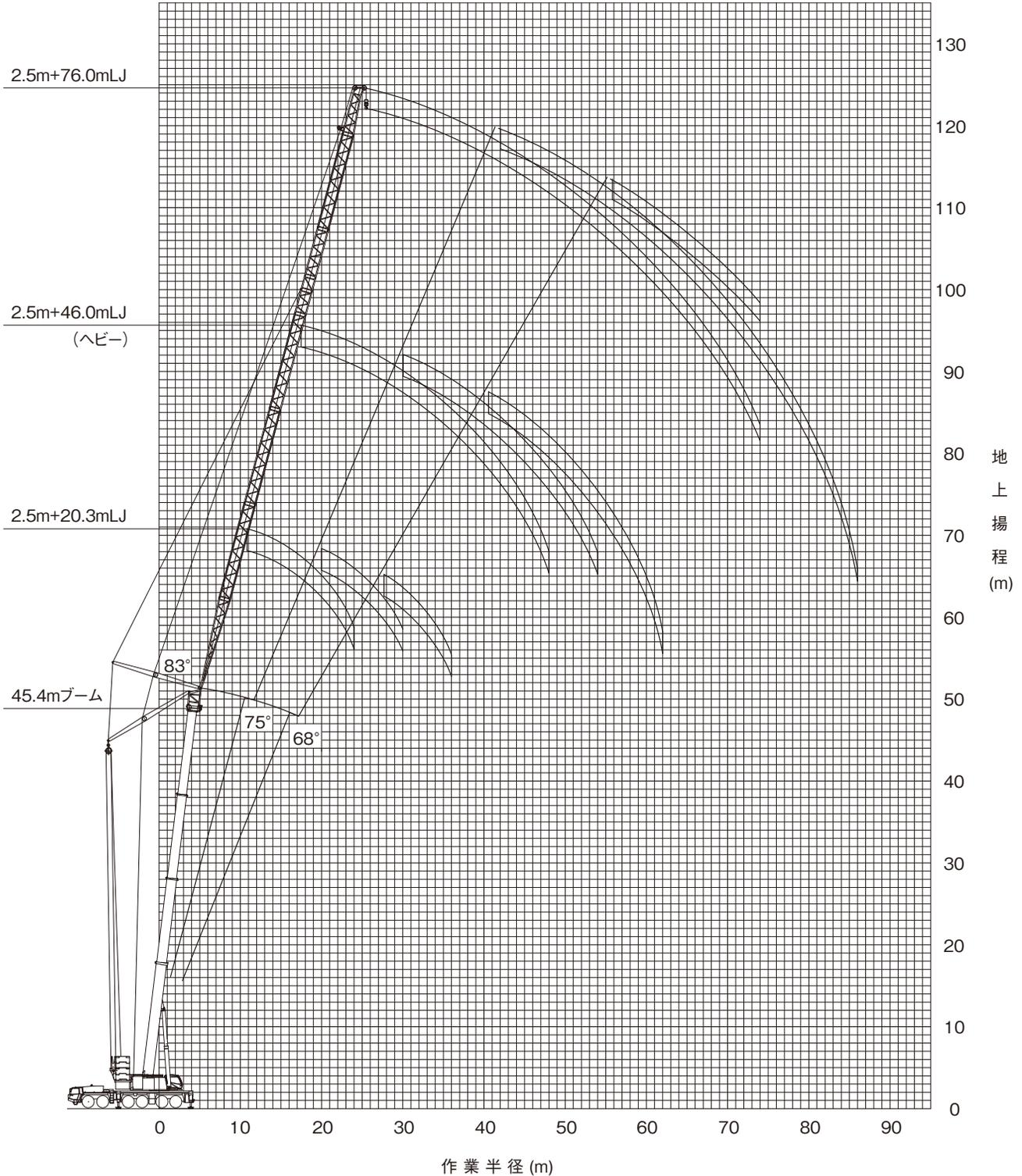

(注意)

- ◆ 上図はブームおよびジブのたわみを含んでいません。
- ◆ カウンタウエイト138t、アウトリガ張出幅8.5mの性能を図示しています。

ブーム+ラフィングジブ(LJ)定格総荷重表

■ 定格総荷重表注意事項

◆性能設定のあるカウンタウエイトとアウトリガ張出幅の組合せを、下表に○印で示します。

アウトリガ張出幅 \ カウンタウエイト	138 t	118 t	98 t	78 t	58 t	47 t
8.5 m	○	○	○	○	○	○
8.0 m	○	○	○	○	○	○
6.8 m	○	○	○	○	○	○

◆定格総荷重は、つり具質量とフック質量(80トンフック: 1,550kg、35トンフック:950kg、12.2トンフック:440kg)を含んだ値を示します。

◆定格総荷重は、ブームのたわみを含んだ実際の作業半径に基づいています。

◆各ブーム長さにおける各伸縮ブームの伸長状態(伸長割合%)は、下表のとおりです。

ブーム長さ	15.0 m	20.1 m	25.1 m	30.2 m	35.3 m	40.4 m	45.4 m	50.5 m	55.6 m
伸縮ブーム1	0	45	90	90	90	90	90	90	90
伸縮ブーム2	0	0	0	45	90	90	90	90	90
伸縮ブーム3	0	0	0	0	0	45	90	90	90
伸縮ブーム4	0	0	0	0	0	0	0	45	90

◆Bピン(ブーム固定ピン)を挿入していない状態では使用できません。

◆定格総荷重表中の標準巻掛本数よりも少ない本数で使用する場合、最大荷重の上限は下表のとおりです。

巻掛本数	5本	4本	3本	2本	1本
最大荷重	58.6t	47.4t	35.9t	24.1t	12.2t

◆定格総荷重は、アウトリガを水平堅土上に設置したときの値です。

◆定格総荷重表は、風による影響を含んでいません。瞬間最大風速が10m/s以上の風速では、クレーン作業を中止してください。

定格総荷重表中の線、および用語説明

◆太線より上側はクレーンの強度に、下側はクレーンの安定に基づいています。

◆「オフセット」は、ブームの中心線とジブの中心線とのなす角度を示します。

◆「 θ (°)」は、無負荷状態で作動可能なジブオフセット角度範囲を示します。

ラフィングジブ

カウンタウエイト 138t、アウトリガ張出幅 8.5m
 ブーム+2.5m+20.3mLJ

ブーム長さ ブーム起伏角 作業半径 (m)	15.0m			20.1m			25.1m			30.2m			35.3m			40.4m			45.4m		
	75°	68°	75°	68°	83°	75°	68°	83°	75°	68°	83°	75°	68°	83°	75°	68°	83°	75°	68°		
14.0					58.6																
16.0	65.0				57.0				53.7												
18.0	58.8				52.0				49.1					45.7			39.0				
20.0	53.7	54.4	50.4		47.1	47.2			45.2				41.6			36.5			30.5		
22.0	49.5	50.0	46.5			43.5			41.9	38.6			38.4			33.6			28.1		
24.0		46.3	43.2		41.8				40.3				35.5			31.9			24.1		
26.0				39.0		37.7			35.3				33.1			29.4					
28.0									32.9					28.4		27.4					
30.0														23.8			21.4		17.7		
32.0																19.6					
34.0																		16.3			
36.0																			13.8		
θ(°)	18~51	18~44	18~57	18~45	18~53	18~66	18~46	18~63	18~52	18~47	18~58	18~57	18~47	18~54	18~67	18~48	18~64	18~52	18~49		
標準フック	80t																				
フック質量	1550kg																				
標準巻掛本数	6			5						4						3					

カウンタウエイト 138t、アウトリガ張出幅 8.5m
 ブーム+2.5m+32.3mLJ

ブーム長さ ブーム起伏角 作業半径 (m)	15.0m			20.1m			25.1m			30.2m			35.3m			40.4m			45.4m			50.5m		
	83°	75°	68°	83°	75°	68°	83°	75°	68°	83°	75°	68°	83°	75°	68°	83°	75°	68°	83°	75°	68°			
12.0	58.6																							
14.0	58.6				47.4			43.5																
16.0	55.2				47.4			42.6				38.1												
18.0	50.3				46.8			41.8				37.5			32.4									
20.0	46.3	47.0			43.6	43.6		41.0				36.8			31.9			22.5						
22.0	42.8	43.5			40.4	40.4		38.1	37.2			35.8			31.5			22.1			17.8			
24.0	39.8	40.4	40.7		37.7	37.6		35.5	34.7			33.5	32.1		30.9			21.7			17.7			
26.0	37.2	37.7	37.9		35.3	35.1	34.7		33.3	32.5			31.4	30.1		29.1			21.3			17.4		
28.0	34.4	35.4	35.6		33.2	33.0	32.5		31.4	30.5			29.6	28.3		27.5	25.7		21.0			17.1		
30.0	28.6	33.3	33.5	31.3	31.1	30.6	29.6		28.7	27.9	28.0	26.7			26.0	22.4		20.7	19.6			16.9		
32.0		31.5	31.6	24.9	29.4	28.9	28.1		27.2	26.3	26.6	23.4	21.6		22.7	20.3		19.6	18.1			16.1		
34.0		24.9	29.9		27.9	27.4			25.8	23.8		21.3	20.0		21.2	19.0	17.8		18.5	16.9				
36.0			28.4		26.5	26.0			23.0	21.7		20.0	18.7		17.7	16.5		15.7				13.2		
38.0					23.0				22.2	20.4		19.0	17.5		16.7	15.4		14.7	13.5			12.3		
40.0										19.3			16.4		15.8	14.4		13.8	12.6			11.5		
42.0													15.5		14.4	13.5		13.0	11.8			10.8		
44.0															12.7			11.0				9.6		
46.0																		10.4				9.0		
48.0																						8.4		
50.0																						7.6		
θ(°)	8~56	8~56	8~49	8~63	8~61	8~50	8~60	8~68	8~51	8~57	8~57	8~51	8~64	8~61	8~52	8~60	8~69	8~53	8~58	8~57	8~53	8~65		
標準フック	80t																							
フック質量	1550kg																							
標準巻掛本数	5			4						3			2											

カウンタウエイト 138t、アウトリガ張出幅 8.5m
 ブーム+2.5m+34.0mLJ

ブーム長さ ブーム起伏角 作業半径 (m)	15.0m			20.1m			25.1m			30.2m			35.3m			40.4m			45.4m			50.5m			55.6m		
	83°	75°	68°	83°	75°	68°	83°	75°	68°	83°	75°	68°	83°	75°	68°	83°	75°	68°	83°	75°	68°						
14.0	40.8				40.7																						
16.0	40.8				40.7			40.1				35.0															
18.0	40.8				40.7			39.4				35.0			29.5												
20.0	40.6	40.8			40.7			38.6				34.6			29.1			21.3									
22.0	37.6	40.8			37.9	39.3		37.0				34.0			28.7			20.9			17.0						
24.0	34.4	38.0			35.4	36.6		34.6	33.7			32.7			28.4			20.5			16.5	13.0					
26.0	31.4	35.0	37.1		32.3	34.2		32.4	31.6			30.7	29.3		27.7			20.2			16.2	12.8					
28.0	28.9	31.9	34.8		29.6	32.1	31.7		30.4	29.6			28.9	27.6		25.3	22.1		19.9		16.1	12.7					
30.0	26.7	29.3	31.9		27.3	30.3	29.8		28.0	28.0	27.1		27.3	24.9		21.6	20.4		19.6	19.5	15.9	12.6					
32.0	24.2	27.1	29.3		25.4	28.5	28.2		26.0	26.4	25.4		25.9	21.5	19.8	20.4	19.0		19.2	18.0	15.8	15.1					
34.0		25.2	27.1		21.2	26.4	26.1		22.5	23.3	21.9		23.1	20.1	18.4	19.4	17.7		18.4	16.8	15.2	14.0					
36.0		21.2	25.1		24.6	22.9		22.0	20.5			18.9	17.1	18.7	16.5	15.7		17.4	15.7		14.1	11.9					
38.0			22.9		21.4	21.7		20.9	19.2			17.9	16.0		15.5	14.6		14.7	13.4		12.2	10.0					
40.0					20.8				18.1			17.0	15.0		14.6	13.6		13.8	12.5		11.4	9.3					
42.0									17.3				14.2		13.9	12.7		13.0	11.7		10.7	10.1					
44.0													13.4			11.9			11.0		10.1	9.5					
46.0															11.2			10.3		9.9	9.1	7.5					
48.0																		9.7		8.9	8.1	7.0					
50.0																			8.3		7.8	6.5					
52.0																				7.8		6.1					
54.0																						5.0					
θ(°)	8~58	8~58	8~51	8~65	8~63	8~52	8~62	8~55	8~53	8~59	8~59	8~53	8~66	8~64	8~54	8~62	8~55	8~55	8~59	8~59	8~56	8~63					
標準フック	80t																										
フック質量	1550kg																										
標準巻掛本数	4			3						3			2			2			1								

カウンタウエイト 138t、アウトリガ張出幅 8.5m
 ブーム+2.5m+40.0mLJ

ブーム長さ ブーム起伏角 作業半径 (m)	15.0m			20.1m			25.1m			30.2m			35.3m			40.4m			45.4m			50.5m			55.6m		
	83°	75°	68°	83°	75°	68°	83°	75°	68°	83°	75°	68°	83°	75°	68°	83°	75°	68°	83°	75°	68°						
14.0	36.7																										
16.0	33.2				33.2																						
18.0	30.3				30.4			30.3																			
20.0	27.5				28.0			28.2				20.6			21.8												
22.0	24.4	27.5			25.1			26.0				20.3			21.4												
24.0	22.1	24.3			22.3	26.0		23.1				19.8			21.0												
26.0	20.3	22.3			20.7	23.2		21.0	24.9			19.0			20.4												
28.0	18.8	20.6			19.2	21.4		19.5	22.2			18.0	19.7		19.6												
30.0	17.5	19.0	20.5		17.8	19.9		18.1	20.7			17.0	19.2		18.5	20.4		16.4									
32.0	16.3	17.7	19.0		16.6	18.4	20.2		16.9	19.2			16.0	18.2		17.4	19.9		16.2								
34.0	15.2	16.5	17.6		15.5	17.2	18.8		15.8	17.9	19.9		15.1	17.2		16.4	19.0		15.8	16.4							
36.0	14.3	15.4	16.4		14.5	16.0	17.5		14.8	16.7	18.6	14.2	16.2		17.9	15.4	17.9		15.2	15.8							
38.0	13.4	14.4	15.4		13.6	15.0	16.3		13.9	15.7	17.3	13.5	15.3		16.9	14.5	16.8		14.5	14.8							
40.0		13.5	14.4		14.1	15.3	13.1		14.7	16.2	12.7	14.4	16.0		13.7	15.8	14.5		13.7	13.9							
42.0					13.2	14.3			13.8	15.2			13.7	15.1		14.9	13.6		13.1	11.8							
44.0					12.5	13.5			13.0	14.3			12.9	14.3		14.1	12.8		12.4	11.1							
46.0						12.7																					

ラフィングジブ

カウンタウエイト 138t、アウトリガ張出幅 8.5m
 ブーム+2.5m+70.0mLJ

ブーム長さ ブーム起伏角 作業半径 (m)	15.0m			20.1m			25.1m			30.2m			35.3m			40.4m			45.4m			50.5m				
	83°	75°	68°	83°	75°	68°	83°	75°	68°	83°	75°	68°	83°	75°	68°	83°	75°	68°	83°	75°	68°	83°	75°	68°		
26.0	15.9			14.9																						
28.0	15.7			14.8					13.8																	
30.0	15.2			14.6					13.6			12.2														
32.0	14.3			14.5					13.5			12.2			10.6			8.4								
34.0	13.6			13.8					13.4			12.1			10.5			8.4			6.3					
36.0	12.9	13.7		13.1					13.3			12.0			10.4			8.3			6.3			4.5		
38.0	12.2	13.0		12.4	13.2				12.6			11.9			10.4			8.3			6.2			4.5		
40.0	11.6	12.3		11.8	12.7				12.0	12.3					10.3			8.2			6.2			4.4		
42.0	11.1	11.7		11.2	12.1				11.4	11.8					10.2			8.1			6.1			4.3		
44.0	10.6	11.2		10.7	11.5				10.9	11.3					10.1			8.1			6.1			4.3		
46.0	10.1	10.7	11.2	10.2	11.0				10.4	10.8					10.1	8.6		8.0			6.1			4.3		
48.0	9.7	10.2	10.7	9.8	10.5	10.3			9.9	10.4					9.7	8.2		8.0	7.0		6.1			4.2		
50.0	9.3	9.8	10.2	9.4	10.0	9.9	9.5	10.0	9.1	9.2	9.2				9.3	7.9		8.0	6.7		6.1	6.1		4.2		
54.0	8.5	9.0	9.4	8.6	9.2	9.2	8.8	9.3	8.4	8.5	8.5	7.4			8.6	7.3		7.9	6.2		6.0	5.9		4.1	4.2	
58.0	7.9	8.3	8.6	8.0	8.5	8.6	8.1	8.6	7.8	7.9	7.9	6.8	8.0	6.7	5.5	7.3	5.7				6.0	5.4		4.0	3.9	
62.0	7.4	7.7	8.0	7.5	7.9	8.1	7.6	8.1	7.2	7.3	7.3	6.3	7.4	6.2	5.0	6.9	5.2	3.9			6.0	4.9	3.4	4.0	3.4	
66.0	7.0	7.3	7.5	7.1	7.4	7.6	7.1	7.6	6.7	6.9	6.8	5.8	7.0	5.8	4.6	6.4	4.8	3.5	5.6	4.5	3.0	4.0	2.9	2.0		2.0
70.0		6.9	7.1		7.0	7.3		7.1	6.3		6.3	5.4	6.6	5.4	4.2	6.1	4.5	3.2	5.1	4.0	2.7	3.6	2.5	1.6		
74.0						6.8			6.8	5.9		6.0	5.0		5.0	3.9		4.1	2.9		3.6	2.4		2.1		
78.0												4.5				3.4		3.9	2.5		3.2	2.0		1.8		
82.0															2.9			2.0			1.5					
θ (°)	8~61	8~57	8~45	8~60	8~54	8~50	8~58	8~61	8~46	8~57	8~57	8~51	8~65	8~54	8~59	8~63	8~61	8~51	8~62	8~57	8~47	8~60	8~54	8~25		
標準フック	35t												12.2t													
フック質量	950kg												440kg													
標準巻掛本数	2												1													

カウンタウエイト 138t、アウトリガ張出幅 8.5m
 ブーム+2.5m+76.0mLJ

ブーム長さ ブーム起伏角 作業半径 (m)	15.0m			20.1m			25.1m			30.2m			35.3m			40.4m			45.4m									
	83°	75°	68°	83°	75°	68°	83°	75°	68°	83°	75°	68°	83°	75°	68°	83°	75°	68°	83°	75°	68°							
28.0	12.8								11.5																			
30.0	12.7			12.1					11.4																			
32.0	12.5			12.0					11.4			10.3																
34.0	12.2			11.7					11.2			10.2			8.9													
36.0	11.9			11.4					10.9			10.1			8.8			6.9					5.1					
38.0	11.5			11.1					10.7			10.0			8.8			6.9					5.0					
40.0	11.1	11.6		10.7					10.4			9.9			8.7			6.8					5.0					
42.0	10.6	11.1		10.2	10.5				10.1			9.7			8.6			6.8					5.0					
44.0	10.1	10.7		9.7	10.1				9.8	9.7		9.5			8.6			6.7					5.0					
46.0	9.6	10.2		9.3	9.8				9.4	9.3		9.2	8.3		8.5			6.7					5.0					
48.0	9.2	9.7		8.9	9.4				9.0	9.0		9.0	8.0		8.3	6.7		6.7					4.9					
50.0	8.8	9.3	9.6	8.5	9.1				8.6	8.6		8.7	7.7		8.0	6.4		6.6	5.5				4.9					
54.0	8.0	8.5	8.8	7.8	8.3	7.9			7.9	8.0		8.0	7.1		7.4	5.9		6.5	5.0				4.8	4.8				
58.0	7.4	7.8	8.1	7.2	7.6	7.3	7.3		7.5	6.6	7.3	6.5	5.5		6.9	5.4		6.3	4.6				4.7	4.3				
62.0	6.8	7.2	7.5	6.6	7.1	6.9	6.7	7.0	6.1	6.8	6.1	5.0	6.5	5.0	3.8	5.8	4.2					4.7	3.9					
66.0	6.4	6.6	6.9	6.2	6.5	6.5	6.2	6.5	5.7	6.3	5.6	4.6	6.1	4.6	3.4	5.5	3.8	2.5				4.7	3.6	2.1				
70.0	6.0	6.2	6.4	5.8	6.1	6.1	5.9	6.1	5.3	5.9	5.3	4.3	5.7	4.2	3.1	5.1	3.5	2.2				4.7	3.2	1.8				
74.0		5.9	6.0		5.8	5.8	5.6	5.8	4.9	5.6	4.9	3.9	5.4	3.9	2.8	4.8	3.2	2.0				4.3	2.9	1.5				
78.0				5.8				5.5				4.6	3.6		3.7	2.5		3.0	1.7				2.6					
82.0									3.9			4.3	3.0		3.4	2.0		2.7					2.4					
86.0															1.5								2.0					
θ (°)	8~58	8~53	8~51	8~57	8~60	8~46	8~64	8~56	8~51	8~62	8~64	8~47	8~61	8~60	8~52	8~60	8~56	8~34	8~59	8~65	8~47	8~60	8~54	8~27				
標準フック	35t												12.2t															
フック質量	950kg												440kg															
標準巻掛本数	2												1															



カウンタウエイト 138t、アウトリガ張出幅 8.5m
ブーム+2.5m+46.0m(ライト)LJ

ブーム長さ		15.0m			20.1m			25.1m			30.2m			35.3m			40.4m			45.4m			50.5m			55.6m			単位:t													
ブーム起伏角 作業半径(m)	83°	75°	68°	83°	75°	68°	83°	75°	68°	83°	75°	68°	83°	75°	68°	83°	75°	68°	83°	75°	68°	83°	75°	68°	83°	75°	68°															
16.0	25.8																																									
18.0	22.8				23.1																																					
20.0	20.6				20.6				20.5																																	
22.0	18.9				19.0				19.1																																	
24.0	17.4	19.1			17.5				17.7																																	
26.0	16.0	17.6			16.2	18.1			16.4																																	
28.0	14.8	16.2			15.0	16.8			15.2																																	
30.0	13.8	15.0			13.9	15.6			14.2	16.1																																
32.0	12.8	13.9	14.9		13.0	14.4			13.2	15.0																																
34.0	12.0	12.9	13.8	12.1	13.5	14.7			12.6	14.0																																
36.0	11.2	12.1	12.9	11.4	12.5	13.6	11.5	13.1	11.8	13.6																																
38.0	10.5	11.3	12.0	10.7	11.7	12.8	10.9	12.2	13.5	11.1	12.7																															
40.0	9.8	10.6	11.3	10.0	11.0	11.9	10.2	11.4	12.7	10.4	11.9	13.4																														
42.0	9.3	9.9	10.6	9.4	10.3	11.2	9.6	10.8	11.8	9.8	11.2	12.6	10.3	12.1																												
44.0	8.7	9.4	9.9	8.9	9.7	10.5	9.1	10.1	11.1	9.2	10.5	11.8	9.7	11.4	12.9																											
46.0		8.8	9.3		9.2	9.9	8.6	9.5	10.5	8.7	9.9	11.1	9.1	10.7	12.2	9.5	11.3	10.5	9.6	9.5																						
48.0		8.3	8.8		8.6	9.3		9.0	9.8		9.4	10.4		10.1	11.5		10.7	9.9	9.2	9.0	8.2																					
50.0						8.8		8.5	9.3		8.8	9.8		9.5	10.8		10.1	9.3		8.5	7.7																					
54.0									8.3			8.8		8.5	9.6		9.1	8.3		7.6	6.9				5.9	5.1		4.3	3.7													
58.0															8.6				7.5		6.1			5.3	4.5		3.8	3.2														
62.0																					5.5			3.9				2.7														
66.0																								6.6		5.7		4.9	2.3													
θ(°)	8~62	8~61	8~46	8~60	8~55	8~46	8~65	8~58	8~55	8~62	8~53	8~47	8~60	8~66	8~56	8~58	8~58	8~47	8~63	8~53	8~58	8~61	8~66	8~48	8~66	8~58	8~59															
標準フック																						35t																		12.2t		
フック質量																						950kg																		440kg		
標準巻掛本数	3									2												1																				

カウンタウエイト 138t、アウトリガ張出幅 8.5m
ブーム+2.5m+52.0m(ライト)LJ

ブーム長さ		15.0m			20.1m			25.1m			30.2m			35.3m			40.4m			45.4m			50.5m			55.6m			単位:t													
ブーム起伏角 作業半径(m)	83°	75°	68°	83°	75°	68°	83°	75°	68°	83°	75°	68°	83°	75°	68°	83°	75°	68°	83°	75°	68°	83°	75°	68°	83°	75°	68°															
18.0	18.8																																									
20.0	17.2				17.1																																					
22.0	15.8				15.8				15.8																																	
24.0	14.6				14.6				14.7																																	
26.0	13.5				13.5				13.7																																	
28.0	12.5	13.6			12.6				12.7																																	
30.0	11.6	12.6			11.7	13.0			11.9																																	
32.0	10.8	11.7			10.9	12.1			11.1	12.5																																
34.0	10.1	10.8			10.2	11.3			10.3	11.6																																
36.0	9.4	10.2	10.8		9.5	10.5			9.7	10.9																																
38.0	8.8	9.5	10.1		8.9	9.8	10.7		9.1	10.2																																
40.0	8.3	8.9	9.5		8.4	9.2	10.0		8.5	9.6	10.5																															
42.0	7.8	8.3	8.9		7.9	8.6	9.3		8.0	9.0	9.9	8.2	9.3																													
44.0	7.3	7.8	8.3		7.4	8.1	8.8		7.6	8.4	9.3	7.7	8.8	9.8																												
46.0	6.9	7.4	7.8		7.0	7.6	8.2		7.1	7.9	8.7	7.3	8.2	9.2	7.8	9.1	10.4																									
48.0	6.5	7.0	7.4		6.6	7.2	7.8		6.7	7.5	8.2	6.9	7.8	8.7	7.3	8.6	9.8																									
50.0	6.2	6.6	6.9		6.3	6.8	7.3		6.4	7.1	7.7	6.5	7.3	8.2	6.9	8.1	9.2	7.1																								
54.0		5.9	6.2			6.1	6.5			6.3	6.9		6.6	7.3		7.2	8.2																									
58.0										6.2			5.9	6.5		6.4	7.3																									
62.0													5.9			6.5																										
66.0																																										
70.0																																										
θ(°)	8~63	8~62	8~47	8~61	8~56	8~42	8~59	8~52	8~48	8~58	8~62	8~56	8~56	8~56	8~48	8~55	8~52	8~58	8~64	8~62	8~49	8~62	8~57	8~59	8~60	8~52	8~50															
標準フック																						35t																		12.2t		
フック質量																						950kg																		440kg		
標準巻掛本数										2												1																				

カウンタウエイト 138t、アウトリガ張出幅 8.5m
ブーム+2.5m+58.0m(ライト)LJ

ブーム長さ		15.0m			20.1m			25.1m			30.2m			35.3m			40.4m			45.4m			50.5m			55.6m			単位:t
ブーム起伏角 作業半径(m)	83°	75°	68°	83°	75°	68°	83°	75°	68°	83°	75°	68°	83°	75°	68°	83°	75°	68°	83°	75°	68°	83°	75°	68°	83°	75°	68°		
22.0	20.9				19.1																								
24.0	19.9				18.8				16.8																				
26.0	18.8				18.1				16.6																				
28.0	17.6				17.3				16.3																				
30.0	16.7				16.4				16.1																				
32.0	15.7	16.8			15.6				15.4																				
34.0	14.8	15.8			14.8	16.0			14.7																				
36.0	14.0	15.0			14.0	15.2			14.0	15.1																			
38.0	13.3	14.1			13.3	14.4			13.3	14.5																			
40.0	12.6	13.4	14.1		12.7	13.7			12.7	13.9																			
42.0	12.0	12.7	13.4	12.0	13.0	13.8			12.1	13.2																			
44.0	11.4	12.1	12.7	11.5	12.3	13.1			11.5	12.6	12.9																		
46.0	10.8	11.5	12.0	10.9	11.7	12.5			11.0	12.0	12.4																		
48.0	10.3	10.9	11.4	10.4	11.2	11.9			10.5	11.5	11.9	10.8																	
50.0	9.8	10.4	10.9	9.9	10.7	11.3			10.0	10.9	11.5	10.3																	
54.0	9.0	9.5	9.9	9.1	9.7	10.3			9.2	10.0	10.7	9.4																	
58.0		8.7	9.1		8.9	9.4			9.1	9.8		9.6	8.8		8.8	8.9	7.4												
62.0																													

ラフィングジブ

カウンタウエイト 118t、アウトリガ張出幅 8.5m
 ブーム+2.5m+70.0mLJ

ブーム長さ ブーム起伏角 作業半径 (m)	15.0m			20.1m			25.1m			30.2m			35.3m			40.4m			45.4m			50.5m		単位 : t					
	83°	75°	68°	83°	75°	68°	83°	75°	68°	83°	75°	68°	83°	75°	68°	83°	75°	68°	83°	75°	68°	83°	75°						
26.0	15.9			14.9																									
28.0	15.7			14.8					13.8																				
30.0	15.2			14.6					13.6				12.2																
32.0	14.3			14.5					13.5				12.2			10.6			8.4										
34.0	13.6			13.8					13.4				12.1			10.5			8.4										
36.0	12.9	13.7		13.1					13.3				12.0			10.4			8.3			6.3				4.5			
38.0	12.2	13.0		12.4	13.2				12.6				11.9			10.4			8.3			6.2				4.5			
40.0	11.6	12.3		11.8	12.7				12.0	12.3			11.5			10.3			8.2			6.2				4.4			
42.0	11.1	11.7		11.2	12.1				11.4	11.8			11.0	10.8		10.2			8.1			6.1				4.3			
44.0	10.6	11.2		10.7	11.5				10.9	11.3			10.5	10.4		10.1			8.1			6.1				4.3			
46.0	10.1	10.7	11.2	10.2	11.0				10.4	10.8			10.0	10.0		10.1	8.6		8.0			6.1				4.3			
48.0	9.7	10.2	10.7	9.8	10.5	10.3			9.9	10.4			9.6	9.6		9.7	8.2		8.0	7.0		6.1				4.2			
50.0	9.3	9.8	10.2	9.4	10.0	9.9			9.5	10.0	9.1			9.2	9.2		9.3	7.9		8.0	6.7		6.1	6.1		4.2			
54.0	8.5	9.0	9.4	8.6	9.2	9.2			8.8	9.3	8.4			8.5	8.5	7.4	8.6	7.3		7.9	6.2		6.0	5.9		4.1	4.2		
58.0	7.9	8.3	8.6	8.0	8.5	8.6			8.1	8.6	7.8	7.9	7.9	8.8	8.0	6.7	5.5	7.3	5.7		6.0	5.4		6.0	5.4		4.0	3.9	
62.0	7.4	7.7	8.0	7.5	7.9	8.1			7.6	8.1	7.2	7.3	7.3	8.2	7.4	6.2	4.8	6.9	5.2	3.5	6.0	4.9	2.9	4.0	3.4		4.0	3.4	
66.0	7.0	7.3	7.5	7.1	7.4	7.5	7.1		7.6	8.1	7.2	7.3	7.3	8.2	7.4	6.2	4.8	6.9	5.2	3.5	6.0	4.9	2.9	4.0	3.4		4.0	3.4	
70.0		6.9	7.1		7.0	6.6			6.8	5.5		6.1	4.6	6.6	5.1	3.3	6.1	4.1	2.2	5.1	3.7	1.6	3.6	2.5		3.6	2.5		
74.0						5.8			5.9	4.7			5.3	3.9		4.3	2.7		3.5	1.7		3.1				2.1		2.1	
78.0																			2.2			2.5					1.8		1.8
82.0																			1.7										
θ (°)	8~61	8~57	8~45	8~60	8~54	8~50	8~58	8~61	8~46	8~57	8~57	8~51	8~65	8~54	8~59	8~63	8~61	8~35	8~62	8~57	8~27	8~60	8~54						
標準フック					35t															12.2t									
フック質量					950kg															440kg									
標準巻掛本数					2															1									



カウンタウエイト 118t、アウトリガ張出幅 8.0m
 ブーム+2.5m+46.0m(ヘビー)LJ

ブーム長さ ブーム起伏角 作業半径(m)	15.0m			20.1m			25.1m			30.2m			35.3m			40.4m			45.4m			50.5m			55.6m		
	83°	75°	68°	83°	75°	68°	83°	75°	68°	83°	75°	68°	83°	75°	68°	83°	75°	68°	83°	75°	68°	83°	75°	68°	83°	75°	68°
16.0	36.7																										
18.0	35.8																										
20.0	35.1																										
22.0	34.3																										
24.0	33.2																										
26.0	31.2	31.4																									
28.0	29.4	29.5																									
30.0	27.8	27.9																									
32.0	26.4	26.4	26.3																								
34.0	25.1	25.1	25.0	23.4	23.1	22.5																					
36.0	23.9	23.9	23.8	22.5	22.0	21.4																					
38.0	22.1	22.8	22.7	21.6	21.0	20.4																					
40.0	19.7	21.8	21.7	20.7	20.1	19.5																					
42.0	17.0	20.8	20.5	19.3	19.2	18.7																					
44.0	14.4	19.1	19.3	16.7	18.4	17.8																					
46.0		16.8	18.1		17.7	16.7																					
48.0			13.9	17.1		16.8	15.7																				
50.0						14.8																					
54.0							14.9	13.5																			
58.0								12.0																			
62.0																											
66.0																											
θ(°)	8~62	8~61	8~46	8~60	8~55	8~46	8~65	8~58	8~55	8~62	8~53	8~47	8~60	8~66	8~56	8~58	8~58	8~47	8~63	8~53	8~58	8~61	8~66	8~48	8~66	8~58	8~59
標準フック	80t									35t												12.2t					
フック質量	1550kg									950kg												440kg					
標準巻掛本数	4			3						2									1								

カウンタウエイト 118t、アウトリガ張出幅 8.0m
 ブーム+2.5m+52.0m(ヘビー)LJ

ブーム長さ ブーム起伏角 作業半径(m)	15.0m			20.1m			25.1m			30.2m			35.3m			40.4m			45.4m			50.5m			55.6m		
	83°	75°	68°	83°	75°	68°	83°	75°	68°	83°	75°	68°	83°	75°	68°	83°	75°	68°	83°	75°	68°	83°	75°	68°	83°	75°	68°
18.0	29.8																										
20.0	29.2																										
22.0	27.8																										
24.0	26.4																										
26.0	23.5																										
28.0	22.2	24.5																									
30.0	21.0	22.3																									
32.0	19.8	21.1																									
34.0	18.8	19.9																									
36.0	17.8	18.9	19.8																								
38.0	16.9	17.9	18.8	16.9	18.1	18.6																					
40.0	16.1	17.0	17.9	16.1	17.2	17.8																					
42.0	15.3	16.2	17.0	15.3	16.4	17.0																					
44.0	14.6	15.4	16.1	14.6	15.7	16.3																					
46.0	13.9	14.7	15.4	14.0	15.0	15.7																					
48.0	13.2	14.0	14.7	13.4	14.3	15.1																					
50.0	11.8	13.4	14.0	12.8	13.7	14.3																					
54.0		11.6	12.8		12.6	12.8																					
58.0																											
62.0																											
66.0																											
70.0																											
θ(°)	8~63	8~62	8~47	8~61	8~56	8~42	8~59	8~52	8~48	8~58	8~62	8~56	8~56	8~56	8~48	8~55	8~52	8~58	8~64	8~62	8~49	8~62	8~57	8~59	8~60	8~52	8~39
標準フック	35t									950kg												12.2t					
フック質量	1550kg									950kg												440kg					
標準巻掛本数	3			2						2									1								

カウンタウエイト 118t、アウトリガ張出幅 8.0m
 ブーム+2.5m+58.0m(ヘビー)LJ

ブーム長さ ブーム起伏角 作業半径(m)	15.0m			20.1m			25.1m			30.2m			35.3m			40.4m			45.4m			50.5m			55.6m		
	83°	75°	68°	83°	75°	68°	83°	75°	68°	83°	75°	68°	83°	75°	68°	83°	75°	68°	83°	75°	68°	83°	75°	68°	83°	75°	68°
20.0	21.8																										
22.0	20.4																										
24.0	19.1																										
26.0	18.0																										
28.0	16.9																										
30.0	16.0	17.1																									
32.0	15.2	16.2																									
34.0	14.4	15.3																									
36.0	13.7	14.6																									
38.0	13.1	13.9																									
40.0	12.5	13.2	13.9																								
42.0	12.0	12.7	13.2	12.2	13.0	13.8																					
44.0	11.5	12.1	12.7	11.7	12.5	13.2																					
46.0	11.1	11.6	12.1	11.2	12.0	12.6																					
48.0	10.7	11.2	11.6	10.8	11.5	12.1																					
50.0	10.3	10.8	11.2	10.4	11.0	11.6																					
54.0	9.8	10.1	10.4	9.8	10.3	10.8																					
58.0		9.6	9.9		9.8	10.1																					
62.0						9.5																					
66.0							9.4	8.0																			
70.0									5.9																		
74.0																											
θ(°)	8~59	8~55	8~43	8~57	8~52	8~48	8~56	8~60	8~43	8~55	8~55	8~49	8~63	8~52	8~58	8~61	8~60	8~50	8~59	8~56	8~59	8~58	8~67	8~40	8~57	8~60	
標準フック	35t									950kg												12.2t					
フック質量	1550kg									950kg												440kg					
標準巻掛本数	2			2						2									1								

カウンタウエイト 118t、アウトリガ張出幅 8.0m
 ブーム+2.5m+64.0m(ヘビー)LJ

ブーム長さ ブーム起伏角 作業半径(m)	15.0m			20.1m			25.1m			30.2m			35.3m			40.4m			45.4m			5		
----------------------------	-------	--	--	-------	--	--	-------	--	--	-------	--	--	-------	--	--	-------	--	--	-------	--	--	---	--	--

ラフィングジブ

カウンタウエイト 118t、アウトリガ張出幅 8.0m
 ブーム+2.5m+70.0mLJ

ブーム長さ 作業半径(m)	15.0m			20.1m			25.1m			30.2m			35.3m			40.4m			45.4m			50.5m		単位:t	
	83°	75°	68°	83°	75°	68°	83°	75°	68°	83°	75°	68°	83°	75°	68°	83°	75°	68°	83°	75°	68°	83°	75°		
26.0	15.9			14.9																					
28.0	15.7			14.8			13.8																		
30.0	15.2			14.6			13.6			12.2															
32.0	14.3			14.5			13.5			12.2			10.6				8.4								
34.0	13.6			13.8			13.4			12.1			10.5				8.4			6.3					
36.0	12.9	13.7		13.1			13.3			12.0			10.4				8.3			6.3				4.5	
38.0	12.2	13.0		12.4	13.2		12.5			11.9			10.4				8.3			6.2				4.5	
40.0	11.6	12.3		11.8	12.7		12.0	12.3		11.5			10.3				8.2			6.2				4.4	
42.0	11.1	11.7		11.2	12.1		11.4	11.8		11.0	10.8						8.1			6.1				4.3	
44.0	10.6	11.2		10.7	11.5		10.9	11.3		10.5	10.4						8.1			6.1				4.3	
46.0	10.1	10.7	11.2	10.2	11.0		10.4	10.8		10.0	10.0			10.1	8.6		8.0			6.1				4.3	
48.0	9.7	10.2	10.7	9.8	10.5	10.3	9.9	10.4		9.6	9.6			9.7	8.2		8.0	7.0		6.1				4.2	
50.0	9.3	9.8	10.2	9.4	10.0	9.9	9.5	10.0	9.1	9.2	9.2			9.3	7.9		8.0	6.7		6.1	6.1			4.2	
54.0	8.5	9.0	9.4	8.6	9.2	9.2	8.8	9.3	8.4	8.5	8.5	7.4		8.6	7.3		7.9	6.2		6.0	5.9			4.1	4.2
58.0	7.9	8.3	8.6	8.0	8.5	8.6	8.1	8.6	7.8	7.9	7.9	6.8	8.0	6.7	5.4		7.3	5.7		6.0	5.4			4.0	3.9
62.0	7.4	7.7	8.0	7.5	7.9	8.1	7.6	8.1	6.9	7.3	7.3	5.9	7.4	6.2	4.5		6.9	5.2	3.2	6.0	4.9	2.5		4.0	3.4
66.0	7.0	7.3	7.5	7.1	7.4	7.2	7.1	7.3	6.0	6.9	6.6	5.0	7.0	5.5	3.7		6.4	4.5	2.5	5.6	4.1	1.8		4.0	2.9
70.0			6.9	7.1		7.0	6.3			6.4	5.2		5.8	4.2	6.6	4.7	3.0	6.1	3.8	1.9	5.1			3.6	2.5
74.0							5.5			5.7	4.5		5.0	3.6		4.0	2.4		3.2						2.1
78.0													3.0			1.9			2.6						1.6
θ(°)	8~61	8~57	8~45	8~60	8~54	8~50	8~58	8~61	8~46	8~57	8~57	8~51	8~65	8~54	8~46	8~63	8~61	8~30	8~62	8~57	8~22	8~60	8~54		
標準フック	35t											12.2t													
フック質量	950kg											440kg													
標準巻掛本数	2											1													



カウンタウエイト 118t、アウトリガ張出幅 8.0m
ブーム+2.5m+46.0m(ライト)LJ

ブーム長さ 作業半径(m)	15.0m			20.1m			25.1m			30.2m			35.3m			40.4m			45.4m			50.5m			55.6m											
	83°	75°	68°	83°	75°	68°	83°	75°	68°	83°	75°	68°	83°	75°	68°	83°	75°	68°	83°	75°	68°	83°	75°	68°	83°	75°	68°									
16.0	25.8																																			
18.0	22.8																																			
20.0	20.6																																			
22.0	18.9																																			
24.0	17.4	19.1																																		
26.0	16.0	17.6																																		
28.0	14.8	16.2																																		
30.0	13.8	15.0																																		
32.0	12.8	13.9	14.9																																	
34.0	12.0	12.9	13.8	12.1																																
36.0	11.2	12.1	12.9	11.4	12.5																															
38.0	10.5	11.3	12.0	10.7	11.7	12.8																														
40.0	9.8	10.6	11.3	10.0	11.0	11.9	10.2	11.4	12.7	10.4	11.9	13.4	10.9	12.8																						
42.0	9.3	9.9	10.6	9.4	10.3	11.2	9.6	10.8	11.8	9.8	11.2	12.6	10.3	12.1																						
44.0	8.7	9.4	9.9	8.9	9.7	10.5	9.1	10.1	11.1	9.2	10.5	11.8	9.7	11.4	12.9	10.1	12.0																			
46.0		8.8	9.3		9.2	9.9	8.6	9.5	10.5	8.7	9.9	11.1	9.1	10.7	12.2	9.5	11.3	10.5																		
48.0					8.6	9.3			9.0	9.8				9.4	10.4		10.1	11.5																		
50.0						8.8			8.5	9.3				8.8	9.8		9.5	10.8																		
54.0										9.3				8.8			8.5	9.6																		
58.0																		8.6																		
62.0																																				
66.0																																				
θ(°)	8~62	8~61	8~46	8~60	8~55	8~46	8~65	8~58	8~55	8~62	8~53	8~47	8~60	8~66	8~56	8~58	8~58	8~47	8~63	8~53	8~58	8~61	8~66	8~48	8~66	8~58	8~59									
標準フック	35t																																			
フック質量	950kg																																			
標準巻掛本数	3												2												1											

カウンタウエイト 118t、アウトリガ張出幅 8.0m
ブーム+2.5m+52.0m(ライト)LJ

ブーム長さ 作業半径(m)	15.0m			20.1m			25.1m			30.2m			35.3m			40.4m			45.4m			50.5m			55.6m			
	83°	75°	68°	83°	75°	68°	83°	75°	68°	83°	75°	68°	83°	75°	68°	83°	75°	68°	83°	75°	68°	83°	75°	68°	83°	75°	68°	
18.0	18.8																											
20.0	17.2																											
22.0	15.8																											
24.0	14.6																											
26.0	13.5																											
28.0	12.5	13.6																										
30.0	11.6	12.6																										
32.0	10.8	11.7																										
34.0	10.1	10.8																										
36.0	9.4	10.2	10.8	9.5	10.5																							
38.0	8.8	9.5	10.1	8.9	9.8	10.7	9.1	10.2																				
40.0	8.3	8.9	9.5	8.4	9.2	10.0	8.5	9.6	10.5	8.7	9.9	9.3	11.0	9.4	10.9													
42.0	7.8	8.3	8.9	7.9	8.6	9.3	8.0	9.0	9.9	8.2	9.3	8.7	10.3	8.8	10.4													
44.0	7.3	7.8	8.3	7.4	8.1	8.8	7.6	8.4	9.3	7.7	8.8	8.2	9.7	8.4	9.9													
46.0	6.9	7.4	7.8	7.0	7.6	8.2	7.1	7.9	8.7	7.3	8.2	9.2	7.8	9.1	10.4	7.9	9.4											
48.0	6.5	7.0	7.4	6.6	7.2	7.8	6.7	7.5	8.2	6.9	7.8	8.7	7.3	8.6	9.8	7.5	8.9											
50.0	6.2	6.6	6.9	6.3	6.8	7.3	6.4	7.1	7.7	6.5	7.3	8.2	6.9	8.1	9.2	7.1	8.4	8.8										
54.0																												
58.0																												
62.0																												
66.0																												
70.0																												
θ(°)	8~63	8~62	8~47	8~61	8~56	8~42	8~59	8~52	8~48	8~58	8~62	8~56	8~56	8~56	8~48	8~55	8~52	8~58	8~64	8~62	8~49	8~62	8~57	8~58	8~59	8~60	8~50	
標準フック	35t																											
フック質量	950kg																											
標準巻掛本数	2												1															

カウンタウエイト 118t、アウトリガ張出幅 8.0m
ブーム+2.5m+58.0m(ライト)LJ

ブーム長さ 作業半径(m)	15.0m			20.1m			25.1m			30.2m			35.3m			40.4m			45.4m			50.5m			55.6m			
	83°	75°	68°	83°	75°	68°	83°	75°	68°	83°	75°	68°	83°	75°	68°	83°	75°	68°	83°	75°	68°	83°	75°	68°	83°	75°	68°	
22.0	20.9																											
24.0	19.9																											
26.0	18.8																											
28.0	17.6																											
30.0	16.7																											
32.0	15.7	16.8																										
34.0	14.8	15.8																										
36.0	14.0	15.0																										
38.0	13.3	14.1																										
40.0	12.6	13.4	14.1																									
42.0	12.0	12.7	13.4	12.0	13.0	13.8	12.1	13.2																				
44.0	11.4	12.1	12.7	11.5	12.3	13.1	11.5	12.6	12.9	11.8	12.6	11.7	12.2	10.9	11.3													
46.0	10.8	11.5	12.0	10.9	11.7	12.5	11.0	12.0	12.4	11.3	12.1	11.3	11.7	10.6	11.0													
48.0	10.3	10.9	11.4	10.4	11.2	11.9	10.5	11.5	11.9	10.8	11.7	10.6	10.8	11.2	10.4	10.5												
50.0	9.8	10.4	10.9	9.9	10.7	11.3	10.0	10.9	11.5	10.3	11.2	10.2	10.4	10.8	9.4	10.1	10.1											
54.0	9.0	9.5	9.9	9.1	9.7	10.3	9.2	10.0	10.7	9.4	10.4	9.5	9.6	9.8	7.4	8.3	7.7											
58.0																												
62.0																												
66.0																												
70.0																												
74.0																												
θ(°)	8~59	8~55	8~43	8~57	8~52	8~48	8~56	8~60	8~43	8~55	8~55	8~49	8~63	8~52	8~58	8~61	8~60	8~50	8~59	8~56	8~59	8~58	8~67	8~50	8~57	8~60	8~23	
標準フック	35t																											
フック質量	950kg																											
標準巻掛本数	2												1															

カウンタウエイト 98t、アウトリガ張出幅 8.0m
 ブーム+2.5m+20.3mLJ

ブーム長さ ブーム起伏角 作業半径(m)	15.0m			20.1m			25.1m			30.2m			35.3m			40.4m			45.4m									
	83°	75°	68°	83°	75°	68°	83°	75°	68°	83°	75°	68°	83°	75°	68°	83°	75°	68°	83°	75°	68°							
12.0	69.7																											
14.0	69.7			67.0				58.6																				
16.0	63.5	65.0		60.2				57.0			53.7																	
18.0	57.6	58.8		54.7	55.1			52.0			49.1			45.7			39.0											
20.0	42.2	52.0	50.6	44.8	49.9			47.1	47.2		45.2			41.6			36.5			30.5								
22.0		45.9	44.6		44.0				42.2		41.9	38.6			38.4			33.6			28.1							
24.0			40.2		39.4	37.8			37.9			35.5			31.9					24.1								
26.0						34.0			34.2	31.8		32.8						25.8										
28.0										28.9				27.1		27.4		22.1			17.7							
30.0														23.8			21.4											
32.0																	19.6											
34.0																			16.3									
36.0																					13.8							
θ(°)	18~62	18~51	18~44	18~57	18~57	18~45	18~53	18~66	18~46	18~63	18~52	18~47	18~58	18~57	18~47	18~54	18~67	18~48	18~64	18~52	18~49							
標準フック	80t																											
フック質量	1550kg																											
標準巻掛本数	6							5							4							3						

カウンタウエイト 98t、アウトリガ張出幅 8.0m
 ブーム+2.5m+32.3mLJ

ブーム長さ ブーム起伏角 作業半径(m)	15.0m			20.1m			25.1m			30.2m			35.3m			40.4m			45.4m			50.5m						
	83°	75°	68°	83°	75°	68°	83°	75°	68°	83°	75°	68°	83°	75°	68°	83°	75°	68°	83°	75°	68°	83°	75°	68°				
12.0	58.6																											
14.0	58.6			47.4				43.5																				
16.0	55.2			47.4				42.6			38.1																	
18.0	50.3			46.8				41.8			37.5			32.4														
20.0	46.3	47.0		43.6	43.6			41.0			36.8			31.9			22.5											
22.0	42.8	43.5		40.4	40.4			38.1	37.2		35.8			31.5			22.1			17.8				13.7				
24.0	39.8	39.6	38.4	37.7	37.6			35.5	34.7		33.9	32.1				30.9			21.7					13.7				
26.0	36.9	35.6	34.5	35.3	34.0	32.3	33.3	32.3			31.4	30.1				29.1			21.3					13.7				
28.0	33.6	32.3	31.3	32.7	30.8	29.3	31.4	29.3			29.6	27.8				27.5	25.7		21.0					13.5				
30.0	28.6	29.6	28.7	29.9	28.2	26.8	28.9	26.8	24.5	28.0	25.4				26.0	22.4		20.7	19.6					13.3				
32.0		27.2	26.5	24.9	25.9	24.6	26.6	24.6	22.5	25.8	23.3	20.8			22.7	20.3		19.6	18.1			16.1	15.3	13.2				
34.0		24.9	24.5		23.9	22.7			22.7	20.8					21.2	19.0	17.6		18.5	16.9		15.1	14.2	12.9	11.7			
36.0			22.7		22.3	21.0			21.0	19.2					17.7	16.2		15.7				13.2	11.7	10.9	9.4			
38.0						19.5			19.5	17.9					16.7	15.1		14.7	13.5			12.3	11.0	10.1	8.8			
40.0										16.6					15.3	14.0		13.8	12.6			11.5	11.0	9.4	7.6			
42.0															14.3	13.1		13.0	11.7			10.8	10.2	8.8	7.1			
44.0																		12.2				10.9	9.5	8.2	6.6			
46.0																						10.1	8.8	7.1	5.5			
48.0																							8.1	6.6	4.7			
50.0																								6.1	4.0			
θ(°)	8~56	8~56	8~49	8~63	8~61	8~50	8~60	8~68	8~51	8~57	8~57	8~51	8~64	8~61	8~52	8~60	8~69	8~53	8~58	8~57	8~53	8~65	8~62	8~54				
標準フック	80t																											
フック質量	1550kg																											
標準巻掛本数	5							4							3							2						

カウンタウエイト 98t、アウトリガ張出幅 8.0m
 ブーム+2.5m+34.0mLJ

ブーム長さ ブーム起伏角 作業半径(m)	15.0m			20.1m			25.1m			30.2m			35.3m			40.4m			45.4m			50.5m			55.6m			
	83°	75°	68°	83°	75°	68°	83°	75°	68°	83°	75°	68°	83°	75°	68°	83°	75°	68°	83°	75°	68°	83°	75°	68°	83°	75°	68°	
14.0	40.8																											
16.0	40.8							40.1			35.0																	
18.0	40.8							39.4			35.0					29.5												
20.0	40.6	40.8						38.6			34.6					29.1			21.3									
22.0	37.6	40.8						37.9	39.3		34.0					28.7			20.9			17.0						
24.0	34.4	38.0						34.6	33.7		32.7					28.4			20.5			16.5			13.0		9.2	
26.0	31.4	35.0	34.5	32.3	33.6			32.4	31.6		30.7	29.3				27.7			20.2			16.2			12.8		9.0	
28.0	28.9	31.9	31.2	29.6	30.5	28.9	30.4	29.0			28.9	27.6				25.3	22.1		19.9			15.9			12.7		8.7	
30.0	26.7	29.3	28.6	27.3	27.9	26.4	28.0	26.4	24.2	27.3	24.9				21.6	20.4		19.6	19.5		16.1			12.6		8.6		
32.0	24.2	27.0	26.3	25.4	25.6	24.2	26.0	24.2	22.2	25.6	21.5	19.8			20.4	19.0		19.2	18.0		15.8	15.1		12.6		8.5		
34.0		24.9	24.3	21.2	23.6	22.4	22.5	22.4	20.4	23.1	20.1	18.4			19.4	17.7		18.4	16.8		15.2	14.0		12.5	11.6	8.5		
36.0		21.2	22.5		21.9	20.7			20.7	18.9					18.7	16.5	15.7		17.4	15.7		14.1	13.1		11.9	10.7	8.5	
38.0			20.9		20.5	19.2			19.2	17.5					15.5	14.6					14.7	13.2		12.2		10.0	8.5	8.0
40.0						17.9				16.3					14.6	13.6					13.8	12.2		11.4		9.3		7.4
42.0										15.2					14.1						13.0	11.3		10.7		9.7		6.9
44.0															13.2						13.0	11.3		10.7		9.7		6.4
46.0																					10.5			10.1		9.0		6.4
48.0																					9.7			10.1		8.3		6.0
50.0																					9.0			10.1		7.7		5.5
54.0																								7.1		6.5		4.7
θ(°)	8~58	8~58	8~51	8~65	8~63	8~52	8~62	8~55	8~53	8~59	8~59	8~53	8~66	8~64	8~54	8~62	8~55	8~55	8~59	8~59	8~56	8~57	8~64	8~45	8~63	8~55	8~58	
標準フック	80t																											
フック質量	1550kg																											
標準巻掛本数	4							3							2							1						

カウンタウエイト 98t、アウトリガ張出幅 8.0m
 ブーム+2.5m+40.0mLJ

ブーム長さ ブーム起伏角 作業半径(m)	15.0m			20.1m			25.1m			30.2m			35.3m			40.4m			45.4m			50.5m			55.6m			
	83°	75°	68°	83°	75°	68°	83°	75°	68°	83°	75°	68°	83°	75°	68°	83°	75°	68°	83°	75°	68°	83°	75°	68°	83°	75°	68°	
14.0	36.7																											
16.0	33.2																											
18.0	30.3							30.3																				
20.0	27.5							28.2																				
22.0	24.4	27.5						26.0																				
24.0	22.1	24.3						23.1																				
26.0	20.3	22.3						21.0	24.9																			
28.0	18.8	20.6	22.2					19.5	22.2																			
30.0	17.5	19.0	20.5	17.8	19.9			18.1	20.7																			
32.0	16.3	17.7	19.0	16.6	18																							

ラフィングジブ

カウンタウエイト 98t、アウトリガ張出幅 8.0m
 ブーム+2.5m+46.0m(ヘビー)LJ

ブーム長さ ブーム起伏角 作業半径(m)	15.0m			20.1m			25.1m			30.2m			35.3m			40.4m			45.4m			50.5m			55.6m								
	83°	75°	68°	83°	75°	68°	83°	75°	68°	83°	75°	68°	83°	75°	68°	83°	75°	68°	83°	75°	68°	83°	75°	68°	83°	75°	68°						
16.0	36.7																																
18.0	35.8				30.8																												
20.0	35.1				30.2				23.7																								
22.0	34.3				29.7				23.2				18.5		17.9																		
24.0	33.2				29.2				22.8				18.2		17.6																		
26.0	31.2	31.4			28.7				22.4				17.9		17.4			14.9			12.9			10.1									
28.0	29.4	29.5			27.6	27.1			22.0				17.7		17.1			14.8			12.8			10.0									
30.0	27.8	27.9			26.1	25.6			21.7	21.8			17.4		16.9			14.6			12.7			9.9			7.5						
32.0	26.4	25.7	24.8		24.8	24.0			21.4	21.5			17.2	17.3			16.6			14.4			12.5				7.5						
34.0	24.7	23.6	22.8		23.4	22.4	20.8		21.1	20.9			17.0	17.1			16.4	16.6		14.3			12.3				7.4						
36.0	22.9	21.8	21.1		22.1	20.7	19.2		20.8	19.3			16.8	16.9			16.2	16.2		14.2	14.2		12.2				7.3						
38.0	21.3	20.3	19.6		20.5	19.2	17.8		19.7	17.9			16.1	16.6	16.3			15.2		14.1	13.6		12.2	11.8			7.2						
40.0	19.7	18.9	18.2		19.1	17.9	16.6		18.4	16.7			14.9	16.4	15.1			14.0	12.6		11.9	11.1		9.5	8.7		7.1						
42.0	17.0	17.7	17.0		17.8	16.7	15.5		17.2	15.5			13.9	16.2	14.1			13.5	12.2		11.4	10.4		9.1	8.1		6.9						
44.0	14.4	16.6	15.9		16.7	15.6	14.4		16.1	14.5	13.0	15.1		13.1	11.2			14.7	12.3	9.8	13.5	10.8		10.8	9.7		8.7						
46.0		15.6	15.0		14.7	13.5	15.1		13.6	12.1	14.3	12.3		10.4	13.8	11.5	9.0	12.9	10.0		7.2	10.3	9.2		8.2	7.1		6.1					
48.0			13.9	14.1		13.8	12.7		12.8	11.4		11.5	9.6		10.7	8.3			9.2	6.6	9.8	8.5	5.6		7.7	6.7		5.7					
50.0						11.9			12.0	10.6		10.8	8.9		10.0	7.7			8.6	6.0		7.9	5.1			6.3	5.0		5.4				
54.0										9.4			7.7			8.7	6.6			7.4	5.1		6.8	4.2			5.5	4.1		4.0			
58.0																											4.9	3.4		3.5			
62.0																												2.7		1.7			
θ(°)	8~62	8~61	8~46		8~60	8~55	8~46		8~65	8~58	8~55	8~62	8~53	8~47	8~60	8~66	8~56		8~58	8~58	8~47	8~63	8~53	8~58		8~61	8~66	8~48	8~66	8~58	8~42		
標準フック	80t			35t			950kg			35t			950kg			35t			950kg			35t			950kg			35t			950kg		
フック質量	1550kg			950kg			950kg			950kg			950kg			950kg			950kg			950kg			950kg			950kg			950kg		
標準巻掛本数	4			3			2			2			2			2			2			2			2			2			2		

カウンタウエイト 98t、アウトリガ張出幅 8.0m
 ブーム+2.5m+52.0m(ヘビー)LJ

ブーム長さ ブーム起伏角 作業半径(m)	15.0m			20.1m			25.1m			30.2m			35.3m			40.4m			45.4m			50.5m			55.6m								
	83°	75°	68°	83°	75°	68°	83°	75°	68°	83°	75°	68°	83°	75°	68°	83°	75°	68°	83°	75°	68°	83°	75°	68°	83°	75°	68°						
18.0	29.8																																
20.0	29.2				22.3																												
22.0	27.8				21.9				19.6																								
24.0	25.4				21.5				19.3																								
26.0	23.5				21.1				18.9																								
28.0	22.2	24.5			20.7				18.6																								
30.0	21.0	22.3			20.4	20.4			18.4																								
32.0	19.8	21.1			19.5	20.1			18.1	18.1																							
34.0	18.8	19.9			18.6	19.5			17.9	17.9																							
36.0	17.8	18.9	19.8		17.7	19.0			17.5	17.6																							
38.0	16.9	17.9	18.8		16.9	18.1	17.2		16.8	17.2																							
40.0	16.1	17.0	17.7		16.1	17.2	16.0		16.0	16.1																							
42.0	15.3	16.2	16.5		15.3	16.2	14.9		15.3	14.9	13.2	14.2	13.7																				
44.0	14.6	15.4	15.5		14.6	15.2	13.9		14.7	13.9	12.3	14.1	12.7	10.6	14.0	11.5																	
46.0	13.9	14.7	14.5		14.0	14.2	13.0		14.1	13.0	11.5	13.6	11.9	9.8	13.2	10.7	8.1																
48.0	13.2	14.0	13.6		13.4	13.3	12.2		13.5	12.2	10.7	13.0	11.1	9.1	12.4	9.9	7.4																
50.0		11.8	13.4	12.8	12.8	12.5	11.5		12.8	11.4	10.0	12.3	10.4	8.4	11.6	9.2	6.8	10.8															
54.0			11.6	11.4		11.1	10.1		10.1		8.7		9.1	7.2		7.9	5.8																
58.0											7.5		7.9	6.2		6.9	4.9																
62.0														5.3			4.1																
66.0																																	
θ(°)	8~63	8~62	8~47		8~61	8~56	8~42		8~59	8~52	8~48	8~58	8~62	8~56	8~56	8~56	8~48		8~55	8~52	8~48	8~58	8~49		8~62	8~57	8~34	8~60	8~52	8~24			
標準フック	80t			35t			950kg			35t			950kg			35t			950kg			35t			950kg			35t			950kg		
フック質量	1550kg			950kg			950kg			950kg			950kg			950kg			950kg			950kg			950kg			950kg			950kg		
標準巻掛本数	3			2			2			2			2			2			2			2			2			2			2		

カウンタウエイト 98t、アウトリガ張出幅 8.0m
 ブーム+2.5m+58.0m(ヘビー)LJ

ブーム長さ ブーム起伏角 作業半径(m)	15.0m			20.1m			25.1m			30.2m			35.3m			40.4m			45.4m			50.5m			55.6m			
	83°	75°	68°	83°	75°	68°	83°	75°	68°	83°	75°	68°	83°	75°	68°	83°	75°	68°	83°	75°	68°	83°	75°	68°	83°	75°	68°	
20.0	21.8																											
22.0	20.4				19.9																							
24.0	19.1				19.5				17.5																			
26.0	18.0				18.3				17.3																			
28.0	16.9				17.2				17.1																			
30.0	16.0	17.1			16.3				16.6																			
32.0	15.2	16.2			15.4	16.8			15.7																			
34.0	14.4	15.3			14.6	15.9			14.9																			
36.0	13.7	14.6			13.9	15.1			14.2	15.6																		
38.0	13.1	13.9			13.3	14.3			13.5	14.8																		
40.0	12.5	13.2	13.9		12.7	13.6			12.9	14.1																		
42.0	12.0	12.7	13.2		12.2	13.0	13.8		12.3	13.4																		
44.0	11.5	12.1	12.7		11.7	12.5	13.0		11.8	12.8																		
46.0	11.1	11.6	12.1		11.2	12.0	12.1		11.4	12.0	10.2	11.5	10.9															
48.0	10.7	11.2	11.6		10.8	11.5	11.3		10.9	11.2	9.4	11.1	10.1															
50.0	10.3	10.8	11.2		10.4	11.0	10.5		10.6																			



カウンタウエイト 98t、アウトリガ張出幅 8.0m
ブーム+2.5m+46.0m(ライト)LJ

ブーム長さ ブーム起伏角 作業半径(m)	15.0m			20.1m			25.1m			30.2m			35.3m			40.4m			45.4m			50.5m			55.6m																	
	83°	75°	68°	83°	75°	68°	83°	75°	68°	83°	75°	68°	83°	75°	68°	83°	75°	68°	83°	75°	68°	83°	75°	68°	83°	75°	68°															
16.0	25.8																																									
18.0	22.8			23.1																																						
20.0	20.6			20.6			20.5																																			
22.0	18.9			19.0			19.1			18.9			18.2																													
24.0	17.4	19.1		17.5			17.7			17.7			17.8																													
26.0	16.0	17.6		16.2	18.1		16.4			16.5			16.9			15.1			12.7				10.2																			
28.0	14.8	16.2		15.0	16.8		15.2			15.4			15.9			14.8			12.6				10.1																			
30.0	13.8	15.0		13.9	15.6		14.2	16.1		14.4			15.0			14.4			12.5				10.0																			
32.0	12.8	13.9	14.9	13.0	14.4		13.2	15.0		13.5	15.5		14.0			13.8			12.4				9.8																			
34.0	12.0	12.9	13.8	12.1	13.5	14.7	12.4	14.0		12.6	14.5		13.2	15.4		13.2			12.2				9.7																			
36.0	11.2	12.1	12.9	11.4	12.5	13.6	11.5	13.1		11.8	13.6		12.4	14.5		12.6	14.4		12.0				9.6																			
38.0	10.5	11.3	12.0	10.7	11.7	12.8	10.9	12.2	13.5		11.1	12.7		11.6	13.7		11.9	13.9		11.5	12.2		9.6																			
40.0	9.8	10.6	11.3	10.0	11.0	11.9	10.2	11.4	12.7	10.4	11.9	13.4	10.9	12.8		11.3	13.2		11.1	11.4		9.5	9.0																			
42.0	9.3	9.9	10.6	9.4	10.3	11.2	9.6	10.8	11.8	9.8	11.2	12.6	10.3	12.1		10.6	12.3		10.6	10.7		9.3	8.4																			
44.0	8.7	9.4	9.9	8.9	9.7	10.5	9.1	10.1	11.1	9.2	10.5	11.8	9.7	11.4	10.4	10.1	11.4		10.1	10.1		9.0	7.9																			
46.0		8.8	9.3		9.2	9.9	8.6	9.5	10.5	8.7	9.9	11.1	9.1	10.7	9.6	9.5	10.6	7.8	9.6	9.5		8.5	7.4																			
48.0		8.3	8.8		8.6	9.3		9.0	9.8		9.4	10.4		10.1	9.0		9.9	7.2	9.2	9.0	6.3	8.1	7.0																			
50.0					8.8			8.5	9.3		8.8	9.8		9.5	8.3		9.2	6.7		8.5	5.8		6.6																			
54.0									8.3			8.6		8.5	7.2		8.0	5.7		7.5	4.9		5.9	4.7																		
58.0															6.3					4.2			5.3	3.9																		
62.0																				3.5			3.3																			
66.0																							3.3																			
θ(°)	8~82	8~61	8~46	8~60	8~55	8~46	8~65	8~58	8~55	8~62	8~53	8~47	8~60	8~66	8~56	8~58	8~58	8~47	8~63	8~53	8~58	8~61	8~66	8~48	8~66	8~58	8~59															
標準フック																						35t																		12.2t		
フック質量																						950kg																		440kg		
標準巻掛本数	3									2												1																				

カウンタウエイト 98t、アウトリガ張出幅 8.0m
ブーム+2.5m+52.0m(ライト)LJ

ブーム長さ ブーム起伏角 作業半径(m)	15.0m			20.1m			25.1m			30.2m			35.3m			40.4m			45.4m			50.5m			55.6m																	
	83°	75°	68°	83°	75°	68°	83°	75°	68°	83°	75°	68°	83°	75°	68°	83°	75°	68°	83°	75°	68°	83°	75°	68°	83°	75°	68°															
18.0	18.8																																									
20.0	17.2			17.1																																						
22.0	15.8			15.8			15.8																																			
24.0	14.6			14.6			14.7					14.6																														
26.0	13.5			13.5			13.7					13.7				13.9		12.8																								
28.0	12.5	13.6		12.6			12.7					12.8				13.2		12.5				10.8																				
30.0	11.6	12.6		11.7	13.0		11.9					12.0				12.5		12.0				10.7																				
32.0	10.8	11.7		10.9	12.1		11.1	12.5				11.2				11.9		11.5				10.4																				
34.0	10.1	10.8		10.2	11.3		10.3	11.6				10.5	12.0			11.2		11.0				10.2																				
36.0	9.4	10.2	10.8	9.5	10.5		9.7	10.9				9.8	11.3			10.5		10.4				9.8																				
38.0	8.8	9.5	10.1	8.9	9.8		10.7	9.1	10.2			9.2	10.6			9.9	11.0				9.5																					
40.0	8.3	8.9	9.5	8.4	9.2	10.0	8.5	9.6	10.5	8.7	9.9		9.3	11.6			9.4	10.9			9.1	10.2																				
42.0	7.8	8.3	8.9	7.9	8.6	9.3	8.0	9.0	9.9	8.2	9.3		8.7	10.3			8.8	10.4			8.7	9.9																				
44.0	7.3	7.8	8.3	7.4	8.1	8.8	7.6	8.4	9.3	7.7	8.8		8.8	9.8			8.4	9.9			8.3	9.6																				
46.0	6.9	7.4	7.8	7.0	7.6	8.2	7.1	7.9	8.7	7.3	8.2	9.2	7.8	9.1	8.6		7.9	9.4			7.9	9.2																				
48.0	6.5	7.0	7.4	6.6	7.2	7.8	6.7	7.5	8.2	6.9	7.8	8.7	7.3	8.6	7.9	7.5	8.9				7.6	8.9																				
50.0	6.2	6.6	6.9	6.3	6.8	7.3	6.4	7.1	7.7	6.5	7.3	8.2	6.9	8.1	7.3	7.1	8.4	6.0	7.2	8.4		7.0	6.5																			
54.0		5.9	6.2		6.1	6.5		6.3	6.9		6.6	7.3		7.2	6.3		7.4	5.0	6.5	7.4	4.7	6.5	5.8	3.7																		
58.0								6.2			5.9	6.5		6.4	5.4		6.4	4.2		6.4	4.0		5.2	3.0																		
62.0											5.9			5.9			3.5		5.5	3.3		4.6	2.4																			
66.0																	2.9		2.7			1.8																				
θ(°)	8~63	8~62	8~47	8~61	8~56	8~42	8~59	8~52	8~48	8~58	8~62	8~56	8~56	8~48	8~55	8~52	8~58	8~64	8~62	8~49	8~62	8~57	8~43	8~60	8~52	8~30																
標準フック																						35t																		12.2t		
フック質量																						950kg																		440kg		
標準巻掛本数										2												1																				

カウンタウエイト 98t、アウトリガ張出幅 8.0m
ブーム+2.5m+58.0m(ライト)LJ

ブーム長さ ブーム起伏角 作業半径(m)	15.0m			20.1m			25.1m			30.2m			35.3m			40.4m			45.4m			50.5m			55.6m			
	83°	75°	68°	83°	75°	68°	83°	75°	68°	83°	75°	68°	83°	75°	68°	83°	75°	68°	83°	75°	68°	83°	75°	68°	83°	75°	68°	
22.0	20.9			19.1																								
24.0	19.9			18.8			16.8																					
26.0	18.8			18.1			16.6					16.4			14.5													
28.0	17.6			17.3			16.3					16.1			14.4			11.8										
30.0	16.7			16.4			16.1					15.7			14.2			11.7				9.4						
32.0	15.7	16.8		15.6			15.4					15.3			14.1			11.7				9.3						
34.0	14.8	15.8		14.8	16.0		14.7					14.7			13.8			11.6				9.3						
36.0	14.0	15.0		14.0	15.2		14.0	15.1				14.1			13.5			11.5				9.2						
38.0	13.3	14.1		13.3	14.4		13.3	14.5				13.5	14.3			13.1	13.9				11.4							
40.0	12.6	13.4	14.1	12.7	13.7		12.7	13.9				12.9	13.7			12.6	13.3			11.3	11.4							
42.0	12.0	12.7	13.4	12.0	13.0	13.8	12.1	13.2				12.4	13.1			12.2	12.4			11.1	11.4							
44.0	11.4	12.1	12.7	11.5	12.3	13.1	11.5	12.6	11.6	11.8	12.2		11.7	11.4			10.9	10.6			9.0	8.9						
46.0	10.8	11.5	12.0	10.9	11.7	12.5	11.0	12.0	10.8	11.3	11.4		11.3	10.6			10.6	9.8			8.9	8.3						
48.0	10.3	10.9	11.4	10.4	11.2																							

ラフィングジブ

カウンタウエイト 98t、アウトリガ張出幅 6.8m
 ブーム+2.5m+20.3mLJ

ブーム長さ ブーム起伏角 作業半径 (m)	15.0m			20.1m			25.1m			30.2m			35.3m			40.4m			45.4m		
	75°	68°	75°	68°	83°	75°	68°	83°	75°	68°	83°	75°	68°	83°	75°	68°	83°	75°	68°	83°	75°
14.0					58.6																
16.0	60.2				57.0				53.7												
18.0	51.6			49.3	50.7			49.1			45.7				39.0						
20.0	45.0	43.6	43.0		44.2	41.0		43.2			41.6			36.5			30.5				
22.0	39.9	38.6	38.1			36.3		38.2	34.8		37.2			33.6			28.1				
24.0		34.9	34.1		32.5	32.6			31.2		29.5						24.1				
26.0					29.3	29.5		27.2		28.1	26.7				25.2						
28.0						24.7				23.0	24.2				22.1						17.7
30.0									21.0					19.4							
32.0														17.9							
34.0																	15.1				
36.0																					12.8
θ (°)	18~51	18~44	18~57	18~45	18~53	18~66	18~46	18~63	18~52	18~47	18~58	18~57	18~47	18~54	18~67	18~48	18~64	18~52	18~49		
標準フック	80t																				
フック質量	1550kg										950kg										35t
標準巻掛本数	6			5						4						3					

カウンタウエイト 98t、アウトリガ張出幅 6.8m
 ブーム+2.5m+32.3mLJ

ブーム長さ ブーム起伏角 作業半径 (m)	15.0m			20.1m			25.1m			30.2m			35.3m			40.4m			45.4m			50.5m		
	83°	75°	68°	83°	75°	68°	83°	75°	68°	83°	75°	68°	83°	75°	68°	83°	75°	68°	83°	75°	68°	83°	75°	68°
12.0	58.6																							
14.0	58.6			47.4			43.5																	
16.0	55.2			47.4			42.6				38.1													
18.0	50.3			46.8			41.8				37.5				32.4									
20.0	45.0	43.4		43.6	41.2		41.0				36.8			31.9			22.5							
22.0	39.8	38.3		38.7	36.4		37.4	34.4			35.8			31.5			22.1							
24.0	35.6	34.2	33.1	34.6	32.5		33.4	30.7			32.4	28.9			30.9			21.7						
26.0	32.2	30.9	29.8	31.2	29.3	27.6	30.1	27.6			29.2	26.0			28.2			21.3						
28.0	29.3	28.1	27.1	28.4	26.6	25.1	27.4	25.1			26.5	23.6			25.6	22.0		21.0						
30.0	26.8	25.7	24.8	26.0	24.3	22.9	25.0	22.9	20.7	24.2	21.6			23.4	20.1		20.7	18.7						
32.0		23.6	22.9	23.9	22.3	21.0	23.0	21.0	19.0	22.3	19.8	17.4		21.5	18.4		19.6	17.1			16.1	15.3		
34.0		21.8	21.2	20.6	19.4		19.4	17.5			18.2	16.0		19.8	17.0	14.4	18.5	15.8			15.1	14.2		
36.0			19.6		19.3	18.0		18.0	16.2		16.9	14.8			15.7	13.3		14.6				13.2		
38.0					16.7			16.7	15.0		15.7	13.7			14.6	12.3		13.5	10.6			12.3		
40.0								14.0			12.7				13.5	11.3		12.5	9.7			11.5	8.2	
42.0											11.8					10.5		11.7	9.0			10.6	7.5	
44.0																9.7			8.3			6.9	8.2	6.2
46.0																			7.6			6.3	5.6	
48.0																						5.8	5.2	
50.0																							4.7	
θ (°)	8~56	8~56	8~49	8~63	8~61	8~50	8~60	8~68	8~51	8~57	8~57	8~51	8~64	8~61	8~52	8~60	8~69	8~53	8~58	8~57	8~53	8~65	8~62	8~54
標準フック	80t																							
フック質量	1550kg										950kg										35t			
標準巻掛本数	5			4						3						2								

カウンタウエイト 98t、アウトリガ張出幅 6.8m
 ブーム+2.5m+34.0mLJ

ブーム長さ ブーム起伏角 作業半径 (m)	15.0m			20.1m			25.1m			30.2m			35.3m			40.4m			45.4m			50.5m			55.6m		
	83°	75°	68°	83°	75°	68°	83°	75°	68°	83°	75°	68°	83°	75°	68°	83°	75°	68°	83°	75°	68°	83°	75°	68°	83°	75°	68°
14.0	40.8			40.7																							
16.0	40.8			40.7			40.1				35.0																
18.0	40.8			40.7			39.4				35.0				29.5												
20.0	40.6	40.8		40.7			38.6				34.6				29.1			21.3									
22.0	37.6	38.1		37.9	36.0		37.0				34.0				28.7			20.9				17.0					
24.0	34.4	34.0		34.3	32.1		33.1	30.3			32.2				28.4			20.5				16.5			13.0	9.2	
26.0	31.4	30.7	29.8	30.9	28.9		29.8	27.3			29.0	25.8			27.7			20.2				16.2			12.8	9.0	
28.0	28.9	27.9	26.9	28.1	26.2	24.7	27.0	24.7			26.3	23.4			25.1	21.6		19.9				16.1			12.7	8.7	
30.0	26.6	25.5	24.7	25.7	24.0	22.5	24.7	22.6	20.3	24.0	21.3			21.6	19.7		19.6	18.3			15.9			12.6	8.6		
32.0	24.2	23.4	22.7	23.6	22.0	20.7	22.7	20.7	18.6	22.0	19.5	17.1		20.4	18.0		19.2	16.7			15.8	15.1			12.6	8.5	
34.0		21.6	20.9	21.2	20.3	19.1	21.0	19.1	17.2	20.3	18.0	15.7		19.4	16.6		18.4	15.4			15.2	14.0			12.5	11.6	
36.0		20.1	19.4		18.9	17.7		17.7	15.9		16.6	14.5		18.0	15.3	12.8	17.4	14.2			14.1	13.0			11.9	10.7	
38.0			18.0		17.7	16.4		16.4	14.7		15.4	13.4		14.2	11.7		13.1	10.1			13.1	11.9			10.0	8.5	
40.0					15.3			13.7			14.4	12.5		13.2	10.8		12.2	9.3			11.0				9.3	7.4	
42.0								12.7			12.7	11.6		11.6	12.3	10.0		11.3	8.5			10.1	7.0			8.7	6.9
44.0											10.8			9.2				7.8			9.4	6.4				8.1	5.3
46.0														8.5				7.2				5.8				7.6	4.8
48.0																		6.6				5.3				6.4	6.0
50.0																						4.9				4.4	4.1
54.0																							4.9			4.0	3.0
θ (°)	8~58	8~58	8~51	8~65	8~63	8~52	8~62	8~55	8~53	8~59	8~59	8~53	8~66	8~64	8~54	8~62	8~55	8~55	8~59	8~59	8~56	8~57	8~64	8~45	8~63	8~55	8~58
標準フック	80t																										
フック質量	1550kg										950kg										35t						
標準巻掛本数	4			3						3						2			1								

カウンタウエイト 98t、アウトリガ張出幅 6.8m
 ブーム+2.5m+40.0mLJ

ブーム長さ ブーム起伏角 作業半径 (m)	15.0m			20.1m			25.1m			30.2m			35.3m			40.4m			45.4m			50.5m			55.6m		
	83°	75°	68°	83°	75°	68°	83°	75°	68°	83°	75°	68°	83°	75°	68°	83°	75°	68°	83°	75°	68°	83°	75°	68°	83°	75°	68°
14.0	36.7																										
16.0	33.2			33.2																							
18.0	30.3			30.4			30.3																				
20.0	27.5			28.0			28.2				20.6				21.8												
22.0	24.4	27.5		25.1			26.0				20.3				21.4												
24.0	22.1	24.3		22.3	26.0		23.1				19.8				21.0												
26.0	20.3	22.3		20.7	23.2		21.0	24.9			19.0				20.4												
28.0	18.8	20.6	22.2	19.2	21.4		19.5	22.2			18.0	19.7			19.6												
30.0	17.5	19.0	20.5	17.8	19.9		18.1	20.7			17.0	19.2			18.5	19.0		16.4									
32.0	16.3	17.7	19.0	16.6	18.4	20.2	16.9	19.2			16.0	18.2			17.4	17.4											

ラフィングジブ

カウンタウエイト 78t、アウトリガ張出幅 8.0m
 ブーム+2.5m+20.3mLJ

ブーム長さ ブーム起伏角 作業半径 (m)	15.0m			20.1m			25.1m			30.2m			35.3m			40.4m			45.4m			単位:t			
	83°	75°	68°	83°	75°	68°	83°	75°	68°	83°	75°	68°	83°	75°	68°	83°	75°	68°	83°	75°	68°				
12.0	69.7																								
14.0	69.7																								
16.0	61.4	59.4			59.8																				
18.0	52.3	50.5			51.0	48.1																			
20.0	42.2	43.8	42.4		44.2	41.8																			
22.0		38.7	37.4			36.8																			
24.0			33.7			32.9	31.3																		
26.0							28.1																		
28.0																									
30.0																									
32.0																									
34.0																									
36.0																									
θ(°)	18~62	18~51	18~44	18~57	18~57	18~45	18~53	18~68	18~46	18~63	18~52	18~47	18~58	18~57	18~47	18~54	18~67	18~48	18~64	18~52	18~49				
標準フック	80t						80t						35t						35t						
フック質量	1550kg						1550kg						950kg						950kg						
標準巻掛本数	6						5						4						3						

カウンタウエイト 78t、アウトリガ張出幅 8.0m
 ブーム+2.5m+32.3mLJ

ブーム長さ ブーム起伏角 作業半径 (m)	15.0m			20.1m			25.1m			30.2m			35.3m			40.4m			45.4m			50.5m			単位:t
	83°	75°	68°	83°	75°	68°	83°	75°	68°	83°	75°	68°	83°	75°	68°	83°	75°	68°	83°	75°	68°	83°	75°	68°	
12.0	58.6																								
14.0	58.6																								
16.0	55.2																								
18.0	50.3																								
20.0	43.9	42.3																							
22.0	38.6	37.1																							
24.0	34.4	33.0	31.9																						
26.0	31.0	29.7	28.6																						
28.0	28.2	26.9	25.9																						
30.0	25.7	24.6	23.6																						
32.0		22.5	21.8																						
34.0			20.8																						
36.0																									
38.0																									
40.0																									
42.0																									
44.0																									
46.0																									
48.0																									
50.0																									
θ(°)	8~56	8~56	8~49	8~63	8~61	8~50	8~60	8~68	8~51	8~57	8~57	8~51	8~64	8~61	8~52	8~60	8~69	8~53	8~58	8~57	8~53	8~65	8~62	8~54	
標準フック	80t						80t						35t						35t						
フック質量	1550kg						1550kg						950kg						950kg						
標準巻掛本数	5						4						3						2						

カウンタウエイト 78t、アウトリガ張出幅 8.0m
 ブーム+2.5m+34.0mLJ

ブーム長さ ブーム起伏角 作業半径 (m)	15.0m			20.1m			25.1m			30.2m			35.3m			40.4m			45.4m			50.5m			55.6m			単位:t
	83°	75°	68°	83°	75°	68°	83°	75°	68°	83°	75°	68°	83°	75°	68°	83°	75°	68°	83°	75°	68°	83°	75°	68°	83°	75°	68°	
14.0	40.8																											
16.0	40.8																											
18.0	40.8																											
20.0	40.6	40.8																										
22.0	37.6	36.9																										
24.0	34.2	32.8																										
26.0	30.8	29.5	28.6																									
28.0	28.0	26.7	25.7																									
30.0	25.5	24.4	23.6																									
32.0	23.4	22.3	21.6																									
34.0		20.6	19.9																									
36.0			19.1																									
38.0																												
40.0																												
42.0																												
44.0																												
46.0																												
48.0																												
50.0																												
54.0																												
θ(°)	8~58	8~58	8~51	8~65	8~63	8~52	8~62	8~55	8~53	8~59	8~59	8~53	8~66	8~64	8~54	8~62	8~55	8~55	8~59	8~59	8~56	8~57	8~64	8~45	8~63	8~55	8~58	
標準フック	80t						80t						35t						35t									
フック質量	1550kg						1550kg						950kg						950kg									
標準巻掛本数	4						3						2						1									

カウンタウエイト 78t、アウトリガ張出幅 8.0m
 ブーム+2.5m+40.0mLJ

ブーム長さ ブーム起伏角 作業半径 (m)	15.0m			20.1m			25.1m			30.2m			35.3m			40.4m			45.4m			50.5m			55.6m			単位:t
	83°	75°	68°	83°	75°	68°	83°	75°	68°	83°	75°	68°	83°	75°	68°	83°	75°	68°	83°	75°	68°	83°	75°	68°	83°	75°	68°	
14.0	36.7																											
16.0	33.2																											
18.0	30.3																											
20.0	27.5																											
22.0	24.4	27.5																										
24.0	22.1	24.3																										
26.0	20.3	22.3																										
28.0	18.8	20.6	22.2																									
30.0	17.5	19.0	20.5																									
32.0	16.3	17.7	19.0																									
34.0	15.2	16.5	17.6																									
36.0	14.3	15.4	16.4																									
38.0	13.4	14.4	15.4																									
40.0		13.5	14.4																									
42.0			12.8																									
44.0																												
46.0																												
48.0																												
50.0																												
54.0																												
θ(°)	8~60	8~60	8~44</																									

カウンタウエイト 78t、アウトリガ張出幅 6.8m
 ブーム+2.5m+46.0m(ヘビー)LJ

ブーム長さ ブーム起伏角 作業半径(m)	15.0m			20.1m			25.1m			30.2m			35.3m			40.4m			45.4m			50.5m		55.6m		単位:t
	83°	75°	68°	83°	75°	68°	83°	75°	68°	83°	75°	68°	83°	75°	68°	83°	75°	68°	83°	75°	83°	75°	83°	75°		
16.0	36.7																									
18.0	35.8																									
20.0	35.1																									
22.0	31.6																									
24.0	28.1																									
26.0	25.2	23.8																								
28.0	22.8	21.5																								
30.0	20.7	19.5																								
32.0	19.0	17.8	17.0	18.1	16.5																					
34.0	17.4	16.3	15.5	16.6	15.1	13.6	15.7	13.7																		
36.0	16.1	15.1	14.3	15.3	13.9	12.5	14.5	12.6																		
38.0	14.9	13.9	13.2	14.1	12.8	11.5	13.4	11.6	9.6	12.3	9.8															
40.0	13.8	12.9	12.2	13.1	11.9	10.6	12.4	10.7	8.7	11.4	9.0	6.4	10.9	7.8												
42.0	12.9	12.0	11.3	12.2	11.0	9.8	11.5	9.9	8.0	10.5	8.2	5.8	10.1	7.1	4.3	9.0	5.4									
44.0	12.0	11.2	10.5	11.4	10.3	9.1	10.7	9.2	7.3	9.8	7.5	5.2	9.4	6.4	3.8	8.2	4.8									
46.0		10.5	9.8		9.5	8.4	10.0	8.5	6.6	9.2	6.8	4.7	8.7	5.8	3.3	7.6	4.3	1.5								
48.0		9.8	9.2		8.9	7.7		7.8	6.1		6.3	4.2		5.3	2.9											
50.0						7.1		7.2	5.5		5.7	3.8		4.8	2.5											
54.0									4.6			3.0		3.9	1.8											
58.0																										
θ(°)	8~62	8~61	8~46	8~60	8~55	8~46	8~65	8~58	8~55	8~62	8~53	8~47	8~60	8~66	8~41	8~58	8~58	8~20	8~63	8~53	8~61	8~66	8~66	8~66	8~36	
標準フック	80t									35t												12.2t				
フック質量	1550kg									950kg												440kg				
標準巻掛本数	4			3						2												1				

カウンタウエイト 78t、アウトリガ張出幅 6.8m
 ブーム+2.5m+46.0m(ライト)LJ

ブーム長さ ブーム起伏角 作業半径(m)	15.0m			20.1m			25.1m			30.2m			35.3m			40.4m			45.4m			50.5m		55.6m		単位:t
	83°	75°	68°	83°	75°	68°	83°	75°	68°	83°	75°	68°	83°	75°	68°	83°	75°	68°	83°	75°	83°	75°	83°	75°		
16.0	25.8																									
18.0	22.8																									
20.0	20.6																									
22.0	18.9																									
24.0	17.4	19.1																								
26.0	16.0	17.6																								
28.0	14.8	16.2																								
30.0	13.8	15.0																								
32.0	12.8	13.9	14.9	13.0	14.4																					
34.0	12.0	12.9	13.8	12.1	13.5	14.6	12.4	14.0																		
36.0	11.2	12.1	12.9	11.4	12.5	13.5	11.6	13.1																		
38.0	10.5	11.3	12.0	10.7	11.7	12.5	10.9	12.1	10.3	11.1	10.8															
40.0	9.8	10.6	11.3	10.0	11.0	11.5	10.2	11.2	9.4	10.4	10.0	7.5	10.9	8.4												
42.0	9.3	9.9	10.6	9.4	10.3	10.7	9.6	10.4	8.6	9.8	9.2	6.8	10.3	7.7												
44.0	8.7	9.4	9.9	8.9	9.7	10.0	9.1	9.7	7.9	9.2	8.5	6.2	9.7	7.0	4.4	8.8	5.4									
46.0		8.8	9.3		9.2	9.3	8.6	9.0	7.3	8.7	7.8	5.7	9.1	6.4	4.0	8.2	4.9	2.2	7.9	4.3	8.1	4.3	6.4	3.3		
48.0		8.3	8.8		8.6	8.7		8.4	6.7		7.2	5.2		5.9	3.6											
50.0					8.1			7.9	6.2		6.6	4.7		5.4	3.2											
54.0									5.3			3.9		4.5	2.5											
58.0														1.9												
θ(°)	8~62	8~61	8~46	8~60	8~55	8~46	8~65	8~58	8~55	8~62	8~53	8~47	8~60	8~66	8~56	8~58	8~58	8~27	8~63	8~53	8~61	8~66	8~66	8~66	8~45	
標準フック	80t									35t												12.2t				
フック質量	1550kg									950kg												440kg				
標準巻掛本数	3			3						2												1				

ラフィングジブ

カウンタウエイト 58t、アウトリガ張出幅 8.5m
 ブーム+2.5m+20.3mLJ

ブーム長さ ブーム起伏角 作業半径 (m)	15.0m			20.1m			25.1m			30.2m			35.3m			40.4m			45.4m			
	83°	75°	68°	83°	75°	68°	83°	75°	68°	83°	75°	68°	83°	75°	68°	83°	75°	68°	83°	75°	68°	
12.0	69.7																					
14.0	62.8																					
16.0	52.3	50.3			61.0				58.6													
18.0	44.7	42.9			50.8				49.3													
20.0	38.9	37.3	35.9		43.4	40.6			42.0													
22.0		33.0	31.7		36.6	33.2			33.2													
24.0			28.6		27.8	26.2			26.3													
26.0					23.6	23.7			23.7	21.4												
28.0										19.3												
30.0																						
32.0																						
34.0																						
36.0																						
θ (°)	18~62	18~51	18~44	18~57	18~57	18~45	18~53	18~68	18~46	18~63	18~52	18~47	18~58	18~57	18~47	18~54	18~67	18~48	18~64	18~52	18~49	
標準フック	80t																					
フック質量	1550kg																					
標準巻掛本数	6							5							4							

カウンタウエイト 58t、アウトリガ張出幅 8.5m
 ブーム+2.5m+32.3mLJ

ブーム長さ ブーム起伏角 作業半径 (m)	15.0m			20.1m			25.1m			30.2m			35.3m			40.4m			45.4m			50.5m										
	83°	75°	68°	83°	75°	68°	83°	75°	68°	83°	75°	68°	83°	75°	68°	83°	75°	68°	83°	75°	68°	83°	75°	68°								
12.0	58.6																															
14.0	58.6				47.4				43.5																							
16.0	50.6				47.4				42.6																							
18.0	43.1				41.7				40.0																							
20.0	37.4	35.7			36.1	33.6			34.7																							
22.0	32.9	31.4			31.8	29.5			30.5	27.5																						
24.0	29.3	28.0	26.8		28.3	26.2			27.1	24.4																						
26.0	26.4	25.1	24.0		25.5	23.5			24.4	21.9																						
28.0	24.0	22.7	21.8		23.1	21.3			22.1	19.8																						
30.0	21.9	20.7	19.8		21.0	19.4			20.1	18.0																						
32.0	19.0	18.3	17.3		17.7	16.4			18.4	16.4																						
34.0		17.5	16.8		16.3	15.0			15.0	13.1																						
36.0			15.5		15.2	13.8			13.8	12.0																						
38.0					12.8				12.8	11.1																						
40.0									10.2																							
42.0										8.8																						
44.0										8.1																						
46.0																																
48.0																																
θ (°)	8~56	8~56	8~49	8~63	8~61	8~50	8~60	8~68	8~51	8~57	8~57	8~51	8~64	8~61	8~52	8~60	8~69	8~53	8~58	8~57	8~53	8~65	8~62	8~43								
標準フック	80t																															
フック質量	1550kg																															
標準巻掛本数	5								4								3								2							

カウンタウエイト 58t、アウトリガ張出幅 8.5m
 ブーム+2.5m+34.0mLJ

ブーム長さ ブーム起伏角 作業半径 (m)	15.0m			20.1m			25.1m			30.2m			35.3m			40.4m			45.4m			50.5m			55.6m	
	83°	75°	68°	83°	75°	68°	83°	75°	68°	83°	75°	68°	83°	75°	68°	83°	75°	68°	83°	75°	68°	83°	75°	83°	75°	
14.0	40.8								40.7																	
16.0	40.8								40.7																	
18.0	40.8								40.7																	
20.0	37.2	35.5			35.8				34.3																	
22.0	32.7	31.2			31.5	29.1			30.1																	
24.0	29.2	27.8			28.0	25.8			26.8	24.0																
26.0	26.2	24.9	24.0		25.2	23.2			24.0	21.5																
28.0	23.8	22.5	21.6		22.8	20.9			19.4	17.4																
30.0	21.7	20.5	19.8		20.7	19.0			17.6	15.3																
32.0	19.9	18.8	18.1		19.0	17.4			16.1	14.1																
34.0		17.3	16.6		17.5	16.0			14.7	12.7																
36.0		16.0	15.3		14.7	13.5			13.5	11.7																
38.0			14.1		13.8	12.5			12.5	10.8																
40.0					11.5				9.9	8.5																
42.0									9.2	7.8																
44.0										7.1																
46.0																										
48.0																										
50.0																										
θ (°)	8~58	8~58	8~51	8~65	8~63	8~52	8~62	8~55	8~53	8~59	8~59	8~53	8~66	8~64	8~54	8~62	8~55	8~55	8~59	8~59	8~56	8~57	8~64	8~63	8~55	
標準フック	80t																									
フック質量	1550kg																									
標準巻掛本数	4								3								2								1	

カウンタウエイト 58t、アウトリガ張出幅 8.5m
 ブーム+2.5m+40.0mLJ

ブーム長さ ブーム起伏角 作業半径 (m)	15.0m			20.1m			25.1m			30.2m			35.3m			40.4m			45.4m			50.5m			55.6m	
	83°	75°	68°	83°	75°	68°	83°	75°	68°	83°	75°	68°	83°	75°	68°	83°	75°	68°	83°	75°	68°	83°	75°	83°	75°	
14.0	36.7																									
16.0	33.2																									
18.0	30.3																									
20.0	27.5																									
22.0	24.4	27.5																								
24.0	22.1	24.3																								
26.0	20.3	22.3																								
28.0	18.8	20.6	21.2		19.2	20.6			19.5	18.7																
30.0	17.5	19.0	19.3		17.8	18.7			18.1	17.0																
32.0	16.3	17.7	17.6		16.6	17.1			16.9	15.5																
34.0	15.2	16.5	16.2		15.5	15.7			15.8	14.2																
36.0	14.3	15.4	15.1		14.5	14.4			14.8	13.0																
38.0	13.4	14.4	13.9		13.6	13.3			13.7	12.0																
40.0		13.5	12.9		12.4	11.2			12.7	11.1																
42.0		12.6	12.0		11.6	10.4			10.3	8.6																
44.0					10.8	9.7			9.5	7.9																
46.0						9.0				7.3																
48.0										6.7																
50.0																										
θ (°)	8~60	8~60	8~44	8~58	8~64	8~53	8~63	8~56	8~54	8~61	8~60	8~55	8~59	8~65	8~45	8~64	8~57	8~39	8~61</							

カウンタウエイト 58t、アウトリガ張出幅 8.5m
ブーム+2.5m+46.0m(ライト)LJ

単位:t

ブーム長さ ブーム起伏角 作業半径(m)	15.0m			20.1m			25.1m			30.2m			35.3m			40.4m			45.4m			50.5m			55.6m		
	83°	75°	68°	83°	75°	68°	83°	75°	68°	83°	75°	68°	83°	75°	68°	83°	75°	68°	83°	75°	83°	75°	83°	75°			
16.0	25.8																										
18.0	22.8			23.1																							
20.0	20.6			20.6			20.5																				
22.0	18.9			19.0			19.1			18.9			18.2														
24.0	17.4	19.1		17.5			17.7			17.7			17.8														
26.0	16.0	17.6		16.2	18.1		16.4			16.5			16.9			15.1			12.7			10.2					
28.0	14.8	16.2		15.0	16.8		15.2			15.4			15.9			14.8			12.6			10.1			7.8		
30.0	13.8	15.0		13.9	15.6		14.2	16.1		14.4			15.0			14.4			12.5			10.0			7.7		
32.0	12.8	13.9	14.9	13.0	14.4		13.2	15.0		13.5	13.5		14.0			13.8			12.4			9.8			7.6		
34.0	12.0	12.9	13.8	12.1	13.5	14.2	12.4	13.8		12.6	12.3		13.2	10.6		12.8			12.2			9.8			7.5		
36.0	11.2	12.1	12.9	11.4	12.5	13.1	11.6	12.7		11.8	11.3		12.4	9.6		11.7	7.6		11.4			9.7			7.4		
38.0	10.5	11.3	12.0	10.7	11.7	12.1	10.9	11.7		9.8	11.1	10.3		11.6	8.7		10.7	6.8			10.4	6.0	9.6		7.4		
40.0	9.8	10.6	11.3	10.0	11.0	11.1	10.2	10.8	9.0	10.4	9.5	7.0	10.9	7.9		9.9	6.1				9.6	5.4	9.5	5.3	7.3		
42.0	9.3	9.9	10.6	9.4	10.3	10.3	9.6	10.0	8.2	9.8	8.8	6.4	10.2	7.2		9.1	5.5				8.8	4.8	9.1	4.8	7.2		
44.0	8.7	9.4	9.9	8.9	9.7	9.6	9.1	9.3	7.5	9.2	8.1	5.8	9.4	6.6	4.0	8.4	5.0				8.1	4.3	8.4	4.3	6.8	3.2	
46.0		8.8	9.3		9.2	8.9	8.6	8.6	6.9	8.7	7.4	5.2	8.8	6.0	3.5	7.8	4.5	1.7			7.5	3.8	7.7	3.8	6.4	2.8	
48.0		8.3	8.8		8.6	8.3		8.0	6.3		6.8	4.7		5.5	3.1		4.0				6.9	3.4	7.1	3.4	6.1	2.4	
50.0					7.8			7.5	5.8		6.3	4.3		5.0	2.7		3.6				3.0		3.0	5.7	2.1		
54.0									4.9			3.5		4.1	2.1		2.9				2.3			2.3		1.5	
58.0															1.5									1.7			
θ(°)	8~62	8~61	8~46	8~60	8~55	8~46	8~65	8~58	8~55	8~62	8~53	8~47	8~60	8~66	8~56	8~58	8~58	8~20	8~63	8~53	8~61	8~66	8~66	8~45			
標準フック	35t																							12.2t			
フック質量	950kg																							440kg			
標準巻掛本数	3			2																1							

ラフィングジブ

カウンタウエイト 58t、アウトリガ張出幅 8.0m
 ブーム+2.5m+20.3mLJ

ブーム長さ ブーム起伏角 作業半径 (m)	15.0m			20.1m			25.1m			30.2m			35.3m			40.4m			45.4m			単位:t	
	83°	75°	68°	83°	75°	68°	83°	75°	68°	83°	75°	68°	83°	75°	68°	83°	75°	68°	83°	75°	68°		
12.0	69.7																						
14.0	60.9																						
16.0	50.4	48.4			59.1			57.2															
18.0	42.9	41.1			41.6	38.7		47.3			45.9												
20.0	37.2	35.6	34.2		36.0	33.5		40.2			38.9			37.5			36.0						
22.0		31.4	30.1		29.5	29.5		34.8	31.5		33.7			32.5			31.2			30.2			
24.0			27.1		26.3	24.7		29.4	27.6		29.6	26.2		28.6			27.4			26.6			
26.0					22.1	22.3		22.3	19.9		20.9			21.6			19.4			17.8			
28.0									18.0					16.2			17.5			16.1			
30.0														14.7					13.1	14.6			
32.0																			11.9				
34.0																					9.3		
36.0																						7.0	
θ(°)	18~62	18~51	18~44	18~57	18~57	18~45	18~53	18~68	18~46	18~63	18~52	18~47	18~58	18~57	18~47	18~54	18~67	18~48	18~64	18~52	18~49		
標準フック	80t																						
フック質量	1550kg																						
標準巻掛本数	6						5						4						3				

カウンタウエイト 58t、アウトリガ張出幅 8.0m
 ブーム+2.5m+32.3mLJ

ブーム長さ ブーム起伏角 作業半径 (m)	15.0m			20.1m			25.1m			30.2m			35.3m			40.4m			45.4m			50.5m		単位:t
	83°	75°	68°	83°	75°	68°	83°	75°	68°	83°	75°	68°	83°	75°	68°	83°	75°	68°	83°	75°	68°	83°	75°	
12.0	58.6																							
14.0	48.7				47.4			43.5																
16.0	41.3				47.1			42.6			38.1													
18.0	35.7	34.0			39.8	34.4		38.2			36.8			32.4			22.5							
20.0	31.3	29.8			30.2	27.9		28.9	25.8		27.7			26.5			22.1			17.8				
22.0	27.8	26.5	25.3		26.8	24.7		25.6	22.9		24.6	21.0		23.4			21.7			17.7				
24.0	25.0	23.7	22.6		24.1	22.1	20.4		23.0	20.4	22.0	18.8		21.0			20.0			17.4				
26.0	22.7	21.4	20.4		21.8	19.9	18.4		20.7	18.4	19.8	16.9		18.9	15.3		18.0			17.0				
28.0	20.7	19.5	18.6		19.8	18.1	16.7		18.8	16.7	14.5	18.0	15.3		17.1	13.8		16.4	12.4	15.4				
30.0	17.8	17.2	16.1		16.5	15.2	17.2		15.2	13.2	16.5	14.0	11.5		15.6	12.6		14.9	11.2	14.0	9.5			
32.0	16.4	15.7	14.5		15.2	14.0			14.0	12.0	14.0	10.4	8.4		14.3	11.5	8.4		13.7	10.1	12.8	8.6		
34.0					14.1	12.8			12.8	11.0	11.7	9.5		10.5	7.5		9.2			7.7				
36.0						11.8			11.8	10.2	10.8	8.6		9.7	6.8		8.4	5.1		7.0				
38.0									9.4		7.9			8.9	6.2		7.6	4.5		6.3	2.9			
40.0											7.2			5.6			6.9	4.1		5.7	2.5			
42.0														5.0			3.6			2.2				
44.0																	3.2			1.8				
46.0																				1.5				
48.0																								
θ(°)	8~56	8~56	8~49	8~63	8~61	8~50	8~60	8~68	8~51	8~57	8~57	8~51	8~64	8~61	8~52	8~60	8~69	8~53	8~58	8~57	8~53	8~65	8~62	
標準フック	80t																							
フック質量	1550kg																							
標準巻掛本数	5					4					3					2								

カウンタウエイト 58t、アウトリガ張出幅 8.0m
 ブーム+2.5m+34.0mLJ

ブーム長さ ブーム起伏角 作業半径 (m)	15.0m			20.1m			25.1m			30.2m			35.3m			40.4m			45.4m			50.5m		55.6m		単位:t		
	83°	75°	68°	83°	75°	68°	83°	75°	68°	83°	75°	68°	83°	75°	68°	83°	75°	68°	83°	75°	68°	83°	75°	68°	83°		75°	
14.0	40.8				40.7																							
16.0	40.8				40.7			40.1			35.0																	
18.0	40.8				39.5			37.7			35.0			29.5														
20.0	35.5	33.8			34.1			32.6			31.4			29.1			21.3											
22.0	31.1	29.6			29.9	27.5		28.5			27.5			26.0			20.9			17.0								
24.0	27.7	26.3			26.5	24.3		25.3	22.5		24.3			23.0			20.5			16.5					13.0	9.2		
26.0	24.8	23.5	22.6		23.8	21.7		22.6	20.1		21.8	18.5		20.5			19.6			16.2					12.8	9.0		
28.0	22.5	21.2	20.3		21.5	19.6	18.0		20.4	18.1	19.6	16.7		18.5	14.8		17.6			16.1					12.7	8.7		
30.0	20.5	19.3	18.6		19.5	17.8	16.3		18.5	16.4	14.1	17.8	15.1		16.7	13.4		16.0	11.9	15.0					12.6	8.6		
32.0	18.7	17.6	16.9		17.8	16.2	14.9		16.9	14.9	12.8	16.2	13.7	11.2	15.3	12.2		14.6	10.7	13.6	8.9				12.6	8.5		
34.0	16.2	15.5	14.4		16.4	14.9	13.6		15.5	13.6	11.7	14.9	12.5	10.1	14.0	11.1		13.3	9.6	12.4	8.0				11.9	6.9	8.5	
36.0		15.0	14.3		13.7	12.5		12.5	10.7		11.5	9.2	12.8	10.1	7.0		12.2	8.7	11.4	7.2					10.9	6.2	8.5	
38.0			13.2		12.8	11.5		11.5	9.8		10.6	8.3		9.3	6.3		7.9	4.6		6.5					9.5	5.5	8.5	5.3
40.0						10.7			9.1		9.7	7.6		8.4	5.7		7.2	4.1		5.8					8.9	4.9	4.8	
42.0									8.3			6.9		7.7	5.1		6.5	3.6		5.2	2.0				8.4	4.4	4.3	
44.0												6.3					4.6			3.2	4.7	1.7			8.3	3.9	3.8	
46.0																	4.1			2.8					8.2	3.5	3.4	
48.0																			2.4						8.1	3.4	3.4	
θ(°)	8~58	8~58	8~51	8~65	8~63	8~52	8~62	8~55	8~53	8~59	8~59	8~53	8~66	8~64	8~54	8~62	8~55	8~55	8~59	8~59	8~31	8~57	8~64	8~63	8~55	8~63	8~55	
標準フック	80t																											
フック質量	1550kg																											
標準巻掛本数	4				3				3				2				2					1						

カウンタウエイト 58t、アウトリガ張出幅 8.0m
 ブーム+2.5m+40.0mLJ

ブーム長さ ブーム起伏角 作業半径 (m)	15.0m			20.1m			25.1m			30.2m			35.3m			40.4m			45.4m			50.5m		55.6m		単位:t	
	83°	75°	68°	83°	75°	68°	83°	75°	68°	83°	75°	68°	83°	75°	68°	83°	75°	68°	83°	75°	68°	83°	75°	68°	83°		75°
14.0	36.7																										
16.0	33.2				33.2																						
18.0	30.3				30.4			30.3																			
20.0	27.5				28.0			28.2			20.6			21.8													
22.0	24.4	27.5			25.1			26.0			20.3			21.4													
24.0	22.1	24.3			22.3			23.1			19.8			21.0													
26.0	20.3	22.3			20.7	21.4		21.0	19.4		19.0			19.9													
28.0	18.8	20.6			19.9	19.2		19.5	17.4		18.0	15.8		17.9													
30.0	17.5	19.0	18.1		17.8	17.5		18.0	15.7		17.0	14.3		16.2	12.7		14.8										
32.0	16.3	17.4	16.5		16.6	15.9	14.5		16.4	14.3		15.7	13.0		14.7	11.5		13.5									
34.0	15.2	15.9	15.1		15.5	14.6	13.3		15.1																		

カウンタウエイト 47t、アウトリガ張出幅 8.5m
ブーム+2.5m+20.3mLJ

ブーム長さ ブーム起伏角 作業半径(m)	15.0m			20.1m			25.1m			30.2m			35.3m			40.4m			45.4m		
	83°	75°	68°	83°	75°	68°	83°	75°	68°	83°	75°	68°	83°	75°	68°	83°	75°	68°	83°	75°	68°
12.0	69.7																				
14.0	56.2																				
16.0	46.7	44.8			54.4			52.6													
18.0	39.9	38.1			45.2			43.7			42.3										
20.0	34.7	33.1	31.7		38.6	35.8		37.3			36.0			34.7			33.2				
22.0		29.2	27.9		31.9	27.3		32.3	29.0		31.3			30.1			28.7			27.8	
24.0			25.2		24.3	22.7		22.8	25.4		27.4			26.3			25.1			24.3	
26.0					20.3	20.4		18.0	20.4		19.0			19.6			15.9			21.6	
28.0								16.2						17.5			14.3				
30.0												14.5		15.7			12.9			11.8	
32.0															11.5						
34.0															10.4					7.7	
36.0																					5.5
θ(°)	18~62	18~51	18~44	18~57	18~57	18~45	18~53	18~66	18~46	18~63	18~52	18~47	18~58	18~57	18~47	18~54	18~67	18~48	18~64	18~52	18~48
標準フック	80t						35t						35t								
フック質量	1550kg						950kg						950kg								
標準巻掛本数	6			5			4			3			3			2					

カウンタウエイト 47t、アウトリガ張出幅 8.5m
ブーム+2.5m+32.3mLJ

ブーム長さ ブーム起伏角 作業半径(m)	15.0m			20.1m			25.1m			30.2m			35.3m			40.4m			45.4m			50.5m	
	83°	75°	68°	83°	75°	68°	83°	75°	68°	83°	75°	68°	83°	75°	68°	83°	75°	68°	83°	75°	68°	83°	75°
12.0	58.6																						
14.0	45.1				47.4			43.5															
16.0	38.3				43.4			41.5			38.1												
18.0	33.1	31.5			36.9			35.2			33.9			32.3									
20.0	29.2	27.7			31.9	29.4		30.5			29.2			27.8			22.5						
22.0	25.9	24.5	23.3		28.0	25.7		26.7	23.6		25.6			24.3			22.1			17.8		13.7	
24.0	23.2	21.9	20.8		24.8	22.7		23.6	20.9		22.6	19.0		21.4			20.4			17.7		13.7	
26.0	21.0	19.7	18.7		21.1	18.6		21.1	18.6		20.1	16.9		19.1			18.2			17.0		13.7	
28.0	19.1	17.9	17.0		20.1	18.2		19.0	16.7		18.1	15.2		17.2	13.6		16.3			15.3		13.5	
30.0	16.4	15.7	14.4		18.2	16.5		17.2	15.1	12.8	16.4	13.7		15.5	12.2		14.8	10.6		13.8		13.3	
32.0	15.0	14.4	13.2		16.6	15.0	13.7	15.7	13.7	11.7	15.0	12.4	9.8	14.1	11.1		13.4	9.5		12.5	7.8	12.3	
34.0	13.7	13.0	12.0		15.0	13.5	12.5	14.7	12.6	10.6	14.7	12.2	9.5	12.9	10.1	6.8	12.2	8.5		11.4	7.0	11.2	
36.0	12.4	11.6	10.6		14.1	12.6	11.5	13.4	11.5	9.7	13.4	11.1	8.0	11.8	9.2	6.0	11.1	7.7		10.2	6.2	10.2	
38.0	11.6	10.3	9.5		13.0	11.6	10.6	12.2	10.6	8.9	12.2	10.3	7.2	11.5	8.3	5.4	10.9	7.2		9.5	5.6	9.5	
40.0	10.3	9.5	8.8		12.0	11.2	10.3	11.2	10.3	8.6	11.2	9.4	6.5	10.9	8.0	5.5	10.9	7.2		8.5	5.1	8.5	
42.0	9.5	8.8	8.1		11.0	10.3	9.5	10.3	9.5	7.8	10.3	8.6	5.9	10.9	7.9	4.9	10.9	7.2		7.7	4.6	8.5	
44.0	8.8	8.1	7.4		10.3	9.5	8.8	10.3	9.5	7.1	9.5	7.8	5.1	10.9	7.1	4.3	10.9	7.2		7.0	4.1	8.5	
46.0	8.1	7.4	6.7		9.5	8.8	8.1	9.5	8.8	6.4	9.5	7.8	4.8	10.9	6.4	3.8	10.9	7.2		6.5	3.2	8.5	
θ(°)	8~56	8~56	8~49	8~63	8~61	8~50	8~60	8~68	8~51	8~57	8~57	8~51	8~64	8~61	8~52	8~60	8~69	8~53	8~58	8~57	8~23	8~65	8~62
標準フック	80t						35t						35t										
フック質量	1550kg						950kg						950kg										
標準巻掛本数	5			4			3			3			2			2							

カウンタウエイト 47t、アウトリガ張出幅 8.5m
ブーム+2.5m+34.0mLJ

ブーム長さ ブーム起伏角 作業半径(m)	15.0m			20.1m			25.1m			30.2m			35.3m			40.4m			45.4m			50.5m		55.6m	
	83°	75°	68°	83°	75°	68°	83°	75°	68°	83°	75°	68°	83°	75°	68°	83°	75°	68°	83°	75°	68°	83°	75°	83°	75°
14.0	40.8				40.7																				
16.0	38.1				40.7			40.1			35.0														
18.0	33.1	31.5			36.5			34.8			33.6			29.5											
20.0	29.2	27.5			31.6			30.1			29.0			27.3			21.3								
22.0	25.9	24.3			27.7	25.3		26.3			25.3			23.8			20.9			17.0					
24.0	23.0	21.7			24.5	22.3		23.3	20.5		22.3			21.0			19.9			16.5			13.0	9.2	
26.0	20.8	19.5	18.6		21.9	19.9		20.8	18.2		19.9	16.7		18.7			17.7			16.2			12.8	9.0	
28.0	18.9	17.7	17.0		19.8	17.9		18.7	16.3		17.9	14.9		16.7	13.1		15.9			14.8			12.7	8.7	
30.0	17.2	16.2	15.5		17.9	16.2	14.7	16.9	14.8	12.5	16.2	13.5		15.1	11.8		14.4	10.0		13.3			12.6	8.6	
32.0	15.0	14.4	13.2		16.3	14.7	13.4	15.4	13.4	11.3	14.7	12.2	9.5	13.7	10.6		13.0	9.0		12.1	7.2	11.5	8.5		
34.0	13.7	13.0	12.0		15.0	13.5	12.2	14.1	12.2	10.3	13.5	11.1	8.5	12.6	9.6		11.9	8.0		11.0	6.4	10.4	5.3	8.5	
36.0	12.4	11.6	10.6		14.1	12.6	11.5	13.4	11.5	9.4	12.2	9.4	6.5	11.5	8.7	5.5	10.9	7.2		10.0	5.7	9.5	4.6	8.5	
38.0	11.6	10.3	9.5		13.0	11.6	10.6	12.2	10.6	8.9	11.2	8.6	5.9	10.9	7.9	4.9	10.9	7.2		9.5	5.1	4.1	8.5	3.9	
40.0	10.3	9.5	8.8		12.0	11.2	10.3	11.2	10.3	8.6	11.2	8.6	5.9	10.9	7.9	4.9	10.9	7.2		8.5	4.6	4.1	8.5	3.9	
42.0	9.5	8.8	8.1		11.0	10.3	9.5	10.3	9.5	7.8	10.3	8.6	5.9	10.9	7.9	4.9	10.9	7.2		7.7	4.5	3.6	8.5	3.4	
44.0	8.8	8.1	7.4		10.3	9.5	8.8	10.3	9.5	7.1	9.5	7.8	5.1	10.9	7.1	4.3	10.9	7.2		7.0	4.1	3.6	8.5	3.0	
46.0	8.1	7.4	6.7		9.5	8.8	8.1	9.5	8.8	6.4	9.5	7.8	5.1	10.9	6.4	3.8	10.9	7.2		6.5	3.2	4.0	8.5	2.6	
θ(°)	8~58	8~58	8~51	8~65	8~63	8~52	8~62	8~55	8~53	8~59	8~59	8~53	8~66	8~64	8~54	8~62	8~55	8~44	8~59	8~59	8~57	8~64	8~63	8~55	
標準フック	80t						35t						35t												
フック質量	1550kg						950kg						950kg												
標準巻掛本数	4			4			3			3			2			2			1						

カウンタウエイト 47t、アウトリガ張出幅 8.5m
ブーム+2.5m+40.0mLJ

ブーム長さ ブーム起伏角 作業半径(m)	15.0m			20.1m			25.1m			30.2m			35.3m			40.4m			45.4m			50.5m		55.6m	
	83°	75°	68°	83°	75°	68°	83°	75°	68°	83°	75°	68°	83°	75°	68°	83°	75°	68°	83°	75°	68°	83°	75°	83°	75°
14.0	36.7																								
16.0	33.2				33.2																				
18.0	30.3				30.4			30.3																	
20.0	27.5				28.0			28.2																	
22.0	24.4	27.2			25.1			25.7			20.6			21.8											
24.0	22.1	24.0			22.3	22.0		22.7			20.3			21.4			17.5			14.5					
26.0	20.3	21.4			20.7	19.6		20.2	17.5		19.0			18.1			16.4			14.3			11.7	9.4	
28.0	18.8	19.3	18.2		19.2	17.6		18.1	15.7		17.3	14.1		16.2			14.7			14.1			11.2	9.3	
30.0	17.5	17.4	16.5		17.6	15.9		16.4	14.1		15.6	12.7		14.6	11.0		13.2			12.7			10.9	9.2	
32.0	16.3	15.9	15.0		16.1	14.4	13.0	14.9	12.8		14.2	11.5		13.2	9.8		12.0			11.5			10.9	9.1	
34.0	15.2	14.5	13.7		1																				

ラフィングジブ

カウンタウエイト 47t、アウトリガ張出幅 8.0m
 ブーム+2.5m+20.3mLJ

ブーム長さ ブーム起伏角 作業半径 (m)	15.0m			20.1m			25.1m			30.2m			35.3m			40.4m			45.4m			単位 : t
	83°	75°	68°	83°	75°	68°	83°	75°	68°	83°	75°	68°	83°	75°	68°	83°	75°	68°	83°	75°	68°	
12.0	67.7																					
14.0	53.7			51.9			50.0															
16.0	44.4	42.4		42.9			41.3			39.9												
18.0	37.8	36.0		36.5	33.6		35.1			33.8			32.4			30.9						
20.0	32.7	31.1	29.7	31.6	29.1		30.3	27.0		29.2			28.0			26.7					25.8	
22.0		27.4	26.1		25.5			23.7		25.6	22.2			24.6			23.4				22.6	
24.0			23.6		22.7	21.1		21.2		19.7				18.0							20.0	
26.0						18.9		19.0	16.6		17.6			16.1							14.6	
28.0									15.0				13.3		14.5						13.1	
30.0													12.0								11.8	
32.0																10.3						10.7
34.0																						
36.0																					6.6	
θ (°)	18~62	18~51	18~44	18~57	18~57	18~45	18~53	18~68	18~46	18~63	18~52	18~47	18~58	18~57	18~47	18~54	18~67	18~48	18~64	18~52	18~49	
標準フック	80t											35t										
フック質量	1550kg											950kg										
標準巻掛本数	6			5			4			3			2			1						

カウンタウエイト 47t、アウトリガ張出幅 8.0m
 ブーム+2.5m+32.3mLJ

ブーム長さ ブーム起伏角 作業半径 (m)	15.0m			20.1m			25.1m			30.2m			35.3m			40.4m			45.4m			50.5m		単位 : t
	83°	75°	68°	83°	75°	68°	83°	75°	68°	83°	75°	68°	83°	75°	68°	83°	75°	68°	83°	75°	83°	75°		
12.0	58.6																							
14.0	52.1			47.4			43.5																	
16.0	42.8			41.1			39.2			37.6														
18.0	36.1			34.7			33.1			31.7			30.0											
20.0	31.2	29.6		29.9	27.4		28.5			27.2			25.8			22.5								
22.0	27.3	25.9		26.2	23.9		24.9	21.8		23.8			22.5			21.3					17.8	13.7		
24.0	24.3	22.9	21.7	23.2	21.1		22.0	19.3		21.0	17.5		19.9			18.8					17.5	13.7		
26.0	21.8	20.5	19.4	20.8	18.8		17.1	19.7	17.2		18.7	15.5		17.7			16.8				15.6	13.7		
28.0	19.7	18.4	17.5	18.8	16.9	15.4	17.7	15.4		16.8	13.9		15.9	12.3		15.1					14.0	13.5		
30.0	17.9	16.7	15.8	17.0	15.3	13.9	16.1	14.0	11.7	15.3	12.6		14.4	11.1		13.6	9.3				12.6	12.4		
32.0		15.3	14.6	15.6	14.0	12.7	14.7	12.7	10.6	13.9	11.4	8.7	13.1	10.0		12.4	8.3				11.5	6.6	11.2	
34.0			14.0	13.4	12.8	11.6		11.6	9.6		10.4	7.8	11.9	9.0	5.7	11.3	7.5				10.4	5.9	10.2	5.2
36.0				12.3		11.9	10.6		10.6	8.8		9.5	7.0		8.2	5.0		6.7				5.2	9.3	4.6
38.0							9.7		9.7	8.0		8.7	6.3		7.4	4.5		6.0	2.7			4.6		4.1
40.0										7.3			5.7		6.7	3.9		5.4	2.3			4.1		3.6
42.0													5.1			3.5		4.8	1.9			3.6		3.1
44.0																3.0			1.6					2.7
θ (°)	8~56	8~56	8~49	8~63	8~61	8~50	8~60	8~68	8~51	8~57	8~57	8~51	8~64	8~61	8~52	8~60	8~69	8~42	8~58	8~57	8~65	8~62		
標準フック	80t											35t												
フック質量	1550kg											950kg												
標準巻掛本数	5			4			4			3			2			1								

PS+ラフィングジブ

PS+ブーム+ラフィングジブ(LJ)作業半径-揚程図

PS+ブーム+ラフィングジブ

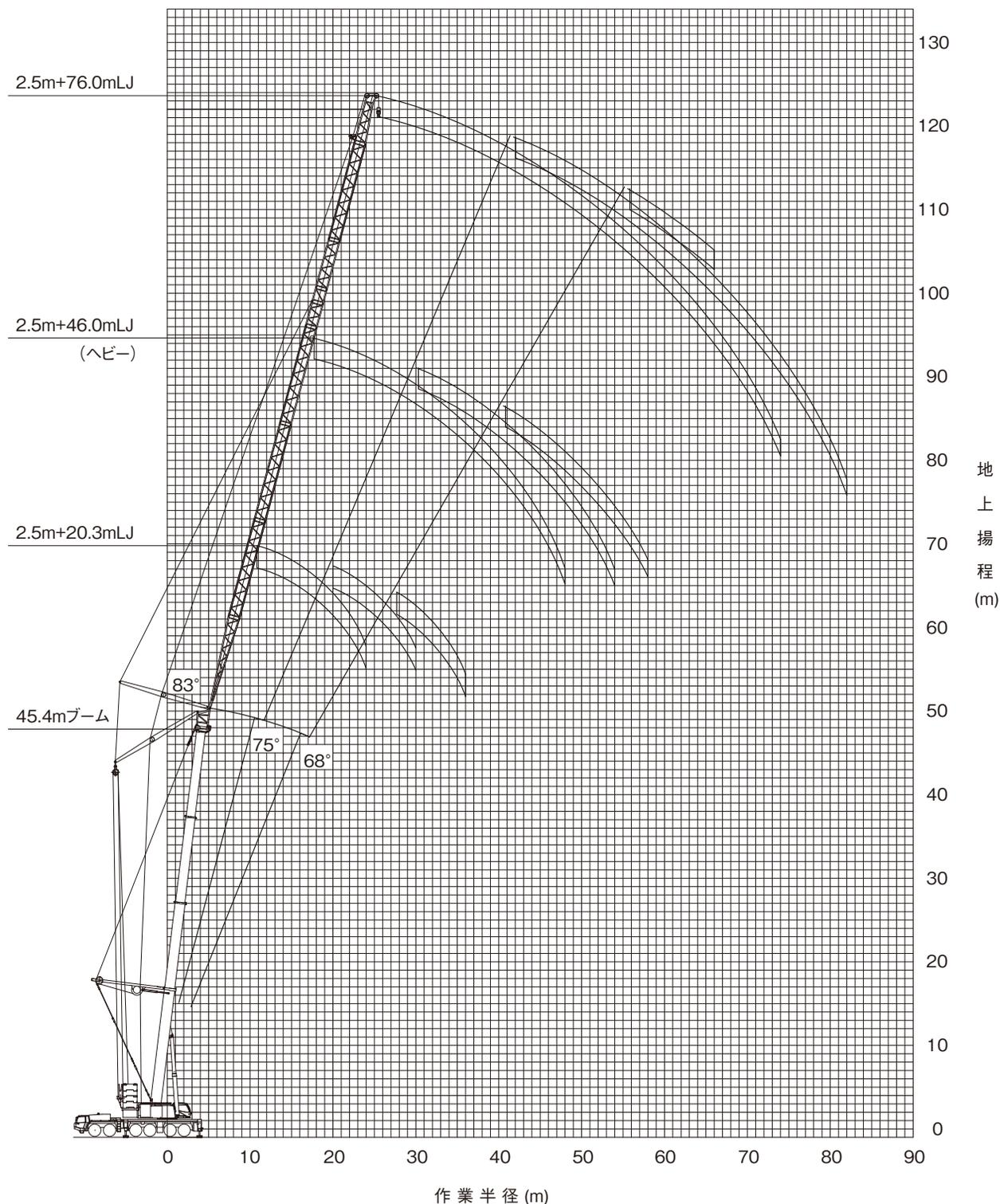

(注意)

- ◆ 上図はブームおよびジブのたわみを含んでいません。
- ◆ カウンタウエイト138t、アウトリガ張出幅8.5mの性能を図示しています。

PS+ブーム+ラフィングジブ(LJ)定格総荷重表

■ 定格総荷重表注意事項

◆性能設定のあるカウンタウエイトとアウトリガ張出幅の組合せを、下表に○印で示します。

アウトリガ張出幅 \ カウンタウエイト	138 t	118 t	98 t	78 t	58 t	47 t
8.5 m	○	○	○	○	○	○
8.0 m	○	○	○	○	○	○
6.8 m	○	○	○	○	○	○

◆定格総荷重は、つり具質量とフック質量(80トンフック: 1,550kg、35トンフック: 950kg、12.2トンフック: 440kg)を含んだ値を示します。

◆定格総荷重は、ブームのたわみを含んだ実際の作業半径に基づいています。

◆各ブーム長さにおける各伸縮ブームの伸長状態(伸長割合%)は、下表のとおりです。

ブーム長さ	35.3 m	40.4 m	45.4 m	50.5 m	55.6 m
伸縮ブーム1	90	90	90	90	90
伸縮ブーム2	90	90	90	90	90
伸縮ブーム3	0	45	90	90	90
伸縮ブーム4	0	0	0	45	90

◆ブーム長さ35.3m未満での性能設定はありません。また、Bピン(ブーム固定ピン)を挿入していない状態では使用できません。

◆定格総荷重表中の標準巻掛本数よりも少ない本数で使用する場合、最大荷重の上限は下表のとおりです。

巻掛本数	3本	2本	1本
最大荷重	35.9t	24.1t	12.2t

◆定格総荷重は、アウトリガを水平堅土上に設置したときの値です。

◆定格総荷重表は、風による影響を含んでいません。瞬間最大風速が10m/s以上の風速では、クレーン作業を中止してください。

定格総荷重表中の線、および用語説明

◆太線より上側はクレーンの強度に、下側はクレーンの安定に基づいています。

◆「オフセット」はブームの中心線とジブの中心線とのなす角度を示します。

◆「 θ (°)」は、無負荷状態で作動可能なジブオフセット角度範囲を示します。

PS+ラフィングジブ

カウンタウエイト 138t、アウトリガ張出幅 8.5m
PS+ブーム+2.5m+20.3mLJ

単位 : t

ブーム長さ	35.3m			40.4m			45.4m		
ブーム起伏角 作業半径 (m)	83°	75°	68°	83°	75°	68°	83°	75°	68°
16.0	39.8								
18.0	35.5			31.1					
20.0	31.7			27.6			26.7		
22.0	28.0			22.0			21.5		
24.0		30.1					18.5		
26.0		27.2			21.4				
28.0		21.3			19.0				
30.0			22.8		16.5			16.4	
32.0			20.3						
34.0					15.9				
36.0									14.0
θ(°)	18~58	18~57	18~47	18~54	18~67	18~48	18~64	18~52	18~49
標準フック	80t			35t					
フック質量	1550kg			950kg					
標準巻掛本数	4			3					

カウンタウエイト 138t、アウトリガ張出幅 8.5m
PS+ブーム+2.5m+32.3mLJ

単位 : t

ブーム長さ	35.3m			40.4m			45.4m			50.5m		
ブーム起伏角 作業半径 (m)	83°	75°	68°	83°	75°	68°	83°	75°	68°	83°	75°	68°
18.0	30.8											
20.0	30.3			20.8								
22.0	29.4			20.3			16.5			12.5		
24.0	26.9			19.9			16.1			12.1		
26.0	22.4			19.0			15.8			11.9		
28.0	20.4	22.8		17.5			15.6			11.7		
30.0	18.6	20.9		16.0	17.7		15.3			11.6		
32.0	16.9	19.3		14.5	16.2		13.9	15.1		11.3		
34.0	15.2	17.8	19.2	13.1	15.0		12.5	14.2		11.0	11.5	
36.0		16.3	17.8		13.8			13.0		11.0	11.2	
38.0		14.9	16.5		12.6	13.7		12.0			10.9	
40.0		13.4	15.3		11.5	12.7		11.0	11.9		10.7	
42.0			14.1		10.3	11.7		9.9	11.0		10.2	
44.0			12.9			10.8			10.2		9.1	10.6
46.0						9.9			9.4			9.4
48.0									8.6			8.6
50.0												7.9
θ(°)	8~64	8~61	8~52	8~60	8~69	8~53	8~58	8~57	8~53	8~65	8~62	8~54
標準フック							35t					
フック質量							950kg					
標準巻掛本数	3						2					

カウンタウエイト 138t、アウトリガ張出幅 8.5m
PS+ブーム+2.5m+34.0mLJ

単位 : t

ブーム長さ	35.3m			40.4m			45.4m			50.5m			55.6m		
ブーム起伏角 作業半径 (m)	83°	75°	68°	83°	75°	68°	83°	75°	68°	83°	75°	68°	83°	75°	68°
18.0	27.8														
20.0	24.4			19.8											
22.0	22.8			19.3			15.6								
24.0	21.2			18.9			15.2			11.5				7.9	
26.0	19.4			18.4			15.0			11.4				7.7	
28.0	17.7	21.2		17.6			14.7			11.4				7.7	
30.0	16.1	19.5		16.1	17.5		14.4			11.1				7.7	
32.0	14.6	18.0		14.6	16.3		13.8	14.4		11.0				7.7	
34.0	12.9	16.6		13.3	15.0		12.7	14.1		10.7	11.1			7.7	
36.0		15.3	17.5	12.0	13.8		11.4	13.2		10.6	10.8			7.5	7.2
38.0		14.0	16.2		12.7	13.6		12.0			10.5			7.2	7.2
40.0		12.8	15.0		11.7	12.6		11.0			10.5			7.0	7.0
42.0		11.4	13.9		10.6	11.7		10.1	11.0					7.0	7.0
44.0			12.9			10.8		9.1	10.1		9.3	10.3		7.0	7.0
46.0			11.8			10.0			9.4		8.3	9.3		6.6	6.9
48.0						9.1			8.6			8.6			6.7
50.0									7.8			7.9			6.4
54.0															6.4
θ(°)	8~56	8~64	8~54	8~62	8~55	8~55	8~59	8~59	8~56	8~57	8~64	8~45	8~63	8~55	8~58
標準フック							35t								
フック質量							950kg						440kg		
標準巻掛本数	3						2						1		

カウンタウエイト 138t、アウトリガ張出幅 8.5m
PS+ブーム+2.5m+40.0mLJ

単位 : t

ブーム長さ	35.3m			40.4m			45.4m			50.5m			55.6m		
ブーム起伏角 作業半径 (m)	83°	75°	68°	83°	75°	68°	83°	75°	68°	83°	75°	68°	83°	75°	68°
20.0	20.8														
22.0	20.4			17.2											
24.0	20.0			16.8			13.4								
26.0	19.6			16.5			13.2			10.3				8.2	
28.0	18.7			16.2			13.1			10.3				8.0	
30.0	17.7	19.1		15.9			13.0			10.2				7.8	
32.0	16.7	18.8		15.6			12.8			10.0				7.7	
34.0	15.7	18.1		15.0	15.4		12.7			9.8				7.5	
36.0	14.8	17.0		14.1	15.0		12.4	12.6		9.7				7.3	
38.0	14.0	15.8		13.0	14.2		11.3	12.1		9.6	9.7			7.2	7.3
40.0	12.9	14.7	15.3	11.9	13.2		10.3	11.4		9.4	9.5			7.0	7.1
42.0		13.6	14.6	10.8	12.3	12.7	9.3	10.5		9.2	9.4			6.9	6.9
44.0		12.6	13.7		11.5	12.1		9.7	10.2		9.2			6.7	6.8
46.0		11.5	12.8		10.6	11.4		9.0	9.5		8.8			6.6	6.6
48.0		10.4	11.9		9.8	10.7		8.3	8.9		8.3	8.8		6.5	6.5
50.0			11.0			10.0		7.5	8.3		7.6	8.1		6.3	6.3
54.0									7.1			7.0			6.0
58.0												5.9			5.8
θ(°)	8~59	8~65	8~45	8~64	8~57	8~39	8~61	8~60	8~46	8~59	8~54	8~58	8~65	8~49	8~47
標準フック							35t						12.2t		
フック質量							950kg						440kg		
標準巻掛本数							2						1		

カウンタウエイト 138t、アウトリガ張出幅 8.5m

PS+ブーム+2.5m+46.0m(ヘビー)LJ

単位:t

ブーム長さ ブーム起伏角 作業半径(m)	35.3m			40.4m			45.4m			50.5m			55.6m		
	83°	75°	68°	83°	75°	68°	83°	75°	68°	83°	75°	68°	83°	75°	68°
22.0	17.1														
24.0	16.8			14.0											
26.0	16.5			13.8			12.0			9.2					
28.0	16.2			13.7			11.8			9.0			6.6		
30.0	16.0			13.5			11.6			8.9			6.5		
32.0	15.7			13.3			11.5			8.7			6.3		
34.0	15.4	15.4		13.2			11.4			8.6			6.2		
36.0	14.8	15.2		13.0	13.1		11.2			8.5			6.1		
38.0	13.7	14.4		12.2	12.9		11.0	11.2		8.3			6.0		
40.0	12.7	13.5		11.3	12.0		10.6	10.9		8.2	8.2		5.9		
42.0	11.8	12.6	12.7	10.5	11.2		9.7	10.2		8.1	8.1		5.8	5.7	
44.0	10.9	11.8	12.1	9.6	10.4		8.9	9.5		7.9	7.9		5.7	5.6	
46.0	9.9	11.0	11.5	8.8	9.7	9.9	8.2	8.9		7.8	7.8		5.6	5.5	
48.0		10.2	10.7		9.0	9.4	7.5	8.3	8.5	7.5	7.7		5.5	5.4	
50.0		9.5	10.1		8.4	8.8		7.7	7.9		7.5	7.5	5.3	5.3	
54.0			8.8		7.1	7.7		6.6	6.9		6.5	6.7		5.0	5.0
58.0						6.6			6.0		5.4	5.8		4.8	4.8
62.0												5.0			4.6
66.0															4.2
θ(°)	8~60	8~49	8~41	8~58	8~58	8~47	8~63	8~53	8~41	8~61	8~66	8~48	8~66	8~58	8~59
標準フック	35t						12.2t								
フック質量	950kg						440kg								
標準巻掛本数	2						1								

カウンタウエイト 138t、アウトリガ張出幅 8.5m

PS+ブーム+2.5m+52.0m(ヘビー)LJ

単位:t

ブーム長さ ブーム起伏角 作業半径(m)	35.3m			40.4m			45.4m			50.5m			55.6m		
	83°	75°	68°	83°	75°	68°	83°	75°	68°	83°	75°	68°	83°	75°	68°
24.0	15.5														
26.0	15.3														
28.0	15.1			12.9			10.5			7.8					
30.0	14.9			12.7			10.3			7.7			5.4		
32.0	14.8			12.5			10.2			7.5			5.4		
34.0	14.6			12.4			10.1			7.4			5.3		
36.0	14.5	14.5		12.3			10.0			7.3			5.2		
38.0	14.4	13.9		12.0			9.9			7.2			5.1		
40.0	14.1	13.3		11.7	11.4		9.7	9.8		7.1			5.0		
42.0	13.2	12.8		10.9	10.9		9.6	9.7		7.0	7.0		4.9		
44.0	12.3	12.2		10.1	10.4		9.4	9.4		7.0	6.9		4.9	4.8	
46.0	11.5	11.7	10.3	9.4	9.9		8.7	9.0		6.9	6.8		4.8	4.7	
48.0	10.6	11.3	9.8	8.7	9.3		8.1	8.4		6.8	6.7		4.7	4.6	
50.0	9.8	10.8	9.4	8.1	8.7	7.7	7.4	7.9		6.7	6.6		4.7	4.5	
54.0		9.5	8.7		7.6	7.1	6.2	6.8	7.0	6.3	6.4	6.1	4.5	4.4	
58.0		8.1	8.1		6.5	6.5		5.9	6.1		5.8	5.5		4.2	4.1
62.0			7.5			6.0		5.0	5.3		4.9	5.1		4.0	3.9
66.0									4.6			4.4			3.8
70.0															3.6
θ(°)	8~56	8~56	8~48	8~55	8~52	8~43	8~64	8~62	8~49	8~62	8~57	8~43	8~60	8~52	8~50
標準フック	35t						12.2t								
フック質量	950kg						440kg								
標準巻掛本数	2						1								

カウンタウエイト 138t、アウトリガ張出幅 8.5m

PS+ブーム+2.5m+58.0m(ヘビー)LJ

単位:t

ブーム長さ ブーム起伏角 作業半径(m)	35.3m			40.4m			45.4m			50.5m			55.6m		
	83°	75°	68°	83°	75°	68°	83°	75°	68°	83°	75°	68°	83°	75°	68°
26.0	14.1														
28.0	13.9			11.2											
30.0	13.8			11.1			8.7								
32.0	13.6			11.0			8.6			6.1			4.1		
34.0	13.4			10.8			8.5			6.0			4.0		
36.0	13.3			10.7			8.3			6.0			3.9		
38.0	13.2	13.2		10.6			8.3			5.9			3.8		
40.0	12.8	12.7		10.5			8.2			5.8			3.8		
42.0	12.1	12.1		10.2	10.3		8.1			5.7			3.7		
44.0	11.4	11.5		10.0	10.1		8.0	8.0		5.7			3.7		
46.0	10.7	11.0		9.3	9.5		7.9	7.9		5.6	5.5		3.6		
48.0	10.0	10.3	9.1	8.7	8.9		7.8	7.7		5.5	5.5		3.6	3.5	
50.0	9.3	9.7	8.7	8.1	8.3		7.4	7.6		5.5	5.4		3.6	3.4	
54.0	8.0	8.5	7.9	7.0	7.3	6.6	6.3	6.5		5.4	5.2		3.4	3.3	
58.0	6.8	7.5	7.2	5.9	6.4	6.1	5.4	5.7	5.0	5.2	5.1	4.1	3.4	3.2	
62.0		6.4	6.7		5.5	5.5		4.9	4.5		4.8	3.7		3.1	3.0
66.0			5.9		4.6	5.0		4.1	4.1		4.0	3.3		3.0	2.6
70.0						4.2			3.7			2.9		2.9	2.3
74.0												2.6			1.9
θ(°)	8~63	8~52	8~44	8~61	8~60	8~50	8~59	8~56	8~44	8~58	8~52	8~50	8~57	8~60	8~45
標準フック	35t						12.2t								
フック質量	950kg						440kg								
標準巻掛本数	2						1								

カウンタウエイト 138t、アウトリガ張出幅 8.5m

PS+ブーム+2.5m+64.0m(ヘビー)LJ

単位:t

ブーム長さ ブーム起伏角 作業半径(m)	35.3m			40.4m			45.4m			50.5m			55.6m		
	83°	75°	68°	83°	75°	68°	83°	75°	68°	83°	75°	68°	83°	75°	68°
28.0	12.3														
30.0	12.1			9.6											
32.0	12.0			9.5			7.4			5.1					
34.0	11.9			9.4			7.3			5.0			3.1		
36.0	11.7			9.3			7.2			5.0			3.1		
38.0	11.6			9.2			7.1			4.9			3.0		
40.0	11.5			9.1			7.0			4.8			3.0		
42.0	11.4	10.4		9.0			7.0			4.8			2.9		
44.0	11.3	10.0		8.9	8.6		6.9			4.7			2.9		
46.0	11.0	9.5		8.8	8.2		6.8	6.8		4.7			2.9		
48.0	10.6	9.1		8.7	7.9		6.8	6.7		4.6	4.5		2.8		
50.0	10.1	8.7		8.3	7.5		6.7	6.5		4.6	4.5		2.8	2.6	
54.0	9.1	8.0	6.6	7.2	6.9		6.4	6.0		4.5	4.4		2.7	2.5	
58.0	7.9	7.4	6.0	6.3	6.4	4.9	5.7	5.5		4.4	4.3		2.6	2.5	
62.0	6.8	6.9	5.5	5.3	5.7	4.4	4.8	5.0	3.4	4.4	4.2	2.9	2.6	2.4	
66.0		6.4	5.1		4.9	4.0		4.3	3.0	4.0	4.1	2.6	2.6	2.3	1.9
70.0		5.6	4.7		4.2	3.6		3.6	2.7		3.5	2.2		2.3	1.6
74.0			4.2			3.3		3.0	2.4		2.9	1.9			2.3
78.0												1.9			
θ(°)	8~59	8~58	8~50	8~58	8~55	8~45	8~56	8~64	8~51	8~64	8~59	8~38	8~63	8~55	8~28
標準フック	35t						12.2t								
フック質量	950kg						440kg								
標準巻掛本数	2						1								

PS+ラフィングジブ

カウンタウエイト 138t、アウトリガ張出幅 8.5m
PS+ブーム+70.0mLJ

単位:t

ブーム長さ ブーム起伏角 作業半径(m)	35.3m			40.4m			45.4m			50.5m		
	83°	75°	68°	83°	75°	68°	83°	75°	68°	83°	75°	68°
32.0	10.3											
34.0	10.2			8.0			6.1					
36.0	10.1			8.0			6.0			3.9		
38.0	10.0			7.9			5.9			3.8		
40.0	9.9			7.8			5.8			3.8		
42.0	9.8			7.8			5.8			3.8		
44.0	9.7			7.7			5.8			3.8		
46.0	9.7	8.4		7.6			5.7			3.8		
48.0	9.6	8.0		7.6	6.7		5.6			3.7		
50.0	9.3	7.7		7.5	6.4		5.6	5.6		3.7		
54.0	8.6	7.1		7.1	5.9		5.5	5.4		3.6	3.5	
58.0	8.0	6.5	5.2	6.4	5.4		5.4	5.0		3.6	3.4	
62.0	7.1	6.0	4.7	5.5	4.9	3.5	5.0	4.5	2.9	3.5	3.3	
66.0	6.2	5.6	4.3	4.7	4.5	3.1	4.2	4.1	2.6	3.5	3.3	1.7
70.0	5.2	5.2	3.9	4.0	4.2	2.8	3.5	3.6	2.2	3.4	3.1	
74.0		4.8	3.6		3.6	2.5		3.1	2.0		2.8	
78.0			3.1		3.0	2.1		2.6	1.5		2.4	
82.0						1.6						
θ(°)	8~65	8~54	8~46	8~63	8~61	8~51	8~62	8~57	8~39	8~60	8~54	8~20
標準フック	12.2t											
フック質量	440kg											
標準巻掛本数	1											

カウンタウエイト 138t、アウトリガ張出幅 8.5m
PS+ブーム+2.5m+76.0mLJ

単位:t

ブーム長さ ブーム起伏角 作業半径(m)	35.3m			40.4m			45.4m		
	83°	75°	68°	83°	75°	68°	83°	75°	68°
34.0	8.6								
36.0	8.6			6.6			4.8		
38.0	8.5			6.5			4.8		
40.0	8.4			6.5			4.8		
42.0	8.3			6.4			4.7		
44.0	8.3			6.4			4.7		
46.0	8.2			6.3			4.6		
48.0	8.1	6.4		6.3			4.6		
50.0	7.9	6.2		6.3	5.2		4.6		
54.0	7.3	5.6		6.2	4.8		4.5	4.3	
58.0	6.8	5.2		6.0	4.3		4.4	3.9	
62.0	6.4	4.8	3.4	5.4	4.0		4.3	3.5	
66.0	6.0	4.4	3.1	4.7	3.6	2.2	4.1	3.2	1.6
70.0	5.4	4.0	2.8	4.0	3.3	1.9	3.5	2.8	
74.0	4.6	3.7	2.5	3.4	3.0	1.6	3.0	2.6	
78.0		3.5	2.2		2.7			2.3	
82.0		3.2	1.7		2.5			2.1	
θ(°)	8~61	8~60	8~43	8~60	8~56	8~29	8~59	8~53	8~18
標準フック	12.2t								
フック質量	440kg								
標準巻掛本数	1								

カウンタウエイト 138t、アウトリガ張出幅 8.5m
PS+ブーム+2.5m+46.0m(ライト)LJ

ブーム長さ ブーム起伏角 作業半径 (m)	35.3m			40.4m			45.4m			50.5m			55.6m		
	83°	75°	68°	83°	75°	68°	83°	75°	68°	83°	75°	68°	83°	75°	68°
22.0	17.7														
24.0	17.1														
26.0	16.4			14.2			12.6			9.3					
28.0	15.5			13.9			12.5			9.1			6.8		
30.0	14.5			13.7			12.3			9.0			6.7		
32.0	13.7			13.2			12.1			8.8			6.5		
34.0	12.8	14.9		12.6			11.9			8.7			6.4		
36.0	12.0	14.1		12.0	13.3		11.5			8.6			6.3		
38.0	11.3	13.2		11.3	13.0		11.1			8.4			6.2		
40.0	10.7	12.4		10.7	12.3		10.6	11.7		8.3	8.4		6.1		
42.0	10.1	11.7	13.2	10.1	11.6		10.2	11.4		8.2	8.2		6.0	5.9	
44.0	9.5	11.0	12.5	9.6	10.8		9.7	10.8		8.1	8.1		5.9	5.8	
46.0	9.0	10.4	11.8	9.1	10.1	10.2	9.1	10.1		7.9	8.0		5.7	5.7	
48.0		9.8	11.1		9.4	9.7	8.4	9.4	9.2	7.7	7.8		5.6	5.6	
50.0		9.3	10.5		8.7	9.2		8.8	8.8		7.7	7.7	5.5	5.5	
54.0			9.3		7.4	8.1		7.6	8.1		6.8	7.1		5.3	5.2
58.0						7.0			7.2		5.6	6.2		5.0	5.0
62.0												5.3			4.8
66.0															4.4
θ(°)	8~60	8~49	8~41	8~58	8~58	8~47	8~63	8~53	8~41	8~61	8~66	8~48	8~66	8~58	8~59
標準フック	35t						12.2t						12.2t		
フック質量	950kg						440kg						440kg		
標準巻掛本数	2						1						1		

カウンタウエイト 138t、アウトリガ張出幅 8.5m
PS+ブーム+2.5m+52.0m(ライト)LJ

ブーム長さ ブーム起伏角 作業半径 (m)	35.3m			40.4m			45.4m			50.5m			55.6m		
	83°	75°	68°	83°	75°	68°	83°	75°	68°	83°	75°	68°	83°	75°	68°
26.0	14.0						10.2			7.8					
28.0	13.3			12.0			10.1			7.6			5.6		
30.0	12.7			11.6			9.8			7.5			5.5		
32.0	12.0			11.1			9.6			7.4			5.4		
34.0	11.4			10.5			9.2			7.3			5.3		
36.0	10.7			10.0			8.9			7.2			5.2		
38.0	10.1	11.7		9.5			8.5	9.4		7.1			5.1		
40.0	9.5	11.0		9.0	10.4		8.2	9.2		7.1	7.0		5.1		
42.0	9.0	10.4		8.5	9.9		7.8	8.8		6.9	7.0		5.0	4.9	
44.0	8.5	9.8		8.0	9.4		7.4	8.5		6.7	6.9		4.9	4.8	
46.0	8.0	9.3	10.4	7.6	8.9		7.1	8.2		6.5	6.8		4.9	4.8	
48.0	7.6	8.7	9.9	7.2	8.4		6.8	7.8		6.3	6.7		4.8	4.7	
50.0	7.2	8.3	9.3	6.8	8.0	8.1	6.1	7.1	7.3	5.8	6.5	6.5	4.6	4.5	
54.0		7.4	8.3		7.2	7.5	6.1	7.1	7.3	5.8	6.5	6.5	4.4	4.3	
58.0		6.7	7.5		6.4	7.0		6.2	6.4	6.0	6.1	6.1	4.4	4.3	
62.0			6.7			6.3		5.2	5.6	5.2	5.5	5.5	4.2	4.1	
66.0								4.9				4.7		4.0	
70.0														3.8	
θ(°)	8~56	8~56	8~48	8~55	8~52	8~43	8~64	8~62	8~49	8~62	8~57	8~43	8~60	8~52	8~50
標準フック	35t						12.2t						12.2t		
フック質量	950kg						440kg						440kg		
標準巻掛本数	2						1						1		

カウンタウエイト 138t、アウトリガ張出幅 8.5m
PS+ブーム+2.5m+58.0m(ライト)LJ

ブーム長さ ブーム起伏角 作業半径 (m)	35.3m			40.4m			45.4m			50.5m			55.6m		
	83°	75°	68°	83°	75°	68°	83°	75°	68°	83°	75°	68°	83°	75°	68°
28.0	14.1														
30.0	13.9			11.3											
32.0	13.8			11.2			8.8								
34.0	13.6			11.1			8.7			6.4			4.4		
36.0	13.4			11.0			8.6			6.3			4.3		
38.0	13.1			10.8			8.5			6.2			4.2		
40.0	12.7	13.3		10.7			8.5			6.1			4.1		
42.0	12.2	13.0		10.6			8.4			6.1			4.1		
44.0	11.8	12.5		10.5	10.5		8.3			6.0			4.0		
46.0	11.4	12.0		10.3	10.4		8.2	8.2		5.9			4.0		
48.0	10.9	11.4		9.7	10.0		8.1	8.1		5.8	5.8		3.9		
50.0	10.3	10.7		9.0	9.3		8.1	8.0		5.8	5.7		3.9	3.7	
54.0	9.6	10.1	9.1	8.4	8.7		7.7	7.9		5.7	5.7		3.8	3.7	
58.0	8.4	8.9	8.4	7.3	7.7	7.2	6.7	6.9		5.6	5.5		3.7	3.6	
62.0	7.1	7.8	7.7	6.2	6.7	6.6	5.7	6.0	5.6	5.5	5.4	4.6	3.7	3.5	
66.0		6.8	7.1		5.8	6.0		5.2	5.1	5.1	4.2		3.4	3.2	
70.0			6.3		4.9	5.3		4.5	4.6	4.4	3.8		3.3	3.2	
74.0					4.6				4.0		3.5		3.2	2.9	
θ(°)	8~63	8~52	8~44	8~61	8~80	8~50	8~59	8~56	8~44	8~58	8~52	8~50	8~57	8~60	8~45
標準フック	35t						12.2t						12.2t		
フック質量	950kg						440kg						440kg		
標準巻掛本数	2						1						1		

カウンタウエイト 138t、アウトリガ張出幅 8.5m
PS+ブーム+2.5m+64.0m(ライト)LJ

ブーム長さ ブーム起伏角 作業半径 (m)	35.3m			40.4m			45.4m			50.5m			55.6m		
	83°	75°	68°	83°	75°	68°	83°	75°	68°	83°	75°	68°	83°	75°	68°
28.0	12.2														
30.0	12.1			9.5											
32.0	11.7			9.5			7.4								
34.0	11.4			9.4			7.3			5.1			3.4		
36.0	11.0			9.3			7.3			5.0			3.3		
38.0	10.6			9.2			7.2			5.0			3.3		
40.0	10.2			9.0			7.1			5.0			3.2		
42.0	9.8	10.8		8.8			7.1			5.0			3.2		
44.0	9.4	10.4		8.6	9.0		7.0			4.9			3.2		
46.0	9.0	10.0		8.3	8.8		6.9	6.9		4.8			3.1		
48.0	8.6	9.6		8.1	8.4		6.9	6.8		4.8	4.7		3.1		
50.0	8.3	9.2		7.8	8.1		6.8	6.8		4.7	4.7		3.1	2.9	
54.0	7.6	8.5	7.2	7.3	7.4		6.6	6.5		4.7	4.6		2.9	2.8	
58.0	7.0	7.8	6.6	6.6	6.8	5.4	6.0	6.0		4.6	4.5		2.9	2.7	
62.0	6.4	7.1	6.1	5.6	6.0	5.0	5.1	5.3	4.0	4.6	4.4	3.3	2.9	2.7	
66.0		6.6	5.6		5.2	4.5		4.6	3.6	4.3	4.3	3.0	2.8	2.6	2.4
70.0		6.1	5.2		4.5	4.2		4.0	3.2	3.8	2.6		2.6	2.1	
74.0			4.9			3.8		3.3	2.9		2.4		2.5	1.8	
78.0									2.6		2.0			1.5	
θ(°)	8~59	8~58	8~50	8~58	8~55	8~45	8~56	8~64	8~51	8~64	8~59	8~46	8~63	8~55	8~42
標準フック	35t						12.2t						12.2t		
フック質量	950kg						440kg						440kg		
標準巻掛本数	2						1						1		

PS+ラフィングジブ

カウンタウエイト 118t、アウトリガ張出幅 8.5m

PS+ブーム+2.5m+20.3mLJ

単位:t

ブーム長さ ブーム起伏角 作業半径 (m)	35.3m			40.4m			45.4m		
	83°	75°	68°	83°	75°	68°	83°	75°	68°
16.0	39.8								
18.0	35.5			31.1					
20.0	31.7			27.6			26.7		
22.0	28.0			22.0			21.5		
24.0		30.1					18.5		
26.0		27.2			21.4				
28.0		21.3			19.0				
30.0			22.8		16.5			16.4	
32.0			20.3						
34.0					15.9				
36.0									14.0
θ(°)	18~58	18~57	18~47	18~54	18~67	18~48	18~64	18~52	18~49
標準フック	80t			35t					
フック質量	1550kg			950kg					
標準巻掛本数	4			3					

カウンタウエイト 118t、アウトリガ張出幅 8.5m

PS+ブーム+2.5m+32.3mLJ

単位:t

ブーム長さ ブーム起伏角 作業半径 (m)	35.3m			40.4m			45.4m			50.5m		
	83°	75°	68°	83°	75°	68°	83°	75°	68°	83°	75°	68°
18.0	30.8											
20.0	30.3			20.8								
22.0	29.4			20.3			16.5			12.5		
24.0	26.9			19.9			16.1			12.1		
26.0	22.4			19.0			15.8			11.9		
28.0	20.4	22.8		17.5			15.6			11.7		
30.0	18.6	20.9		16.0	17.7		15.3			11.6		
32.0	16.9	19.3		14.5	16.2		13.9	15.1		11.3		
34.0	15.2	17.8	19.2	13.1	15.0		12.5	14.2		11.0	11.5	
36.0		16.3	17.8		13.8		13.0			11.0	11.2	
38.0		14.9	16.5		12.6	13.7		12.0			10.9	
40.0		13.4	15.3		11.5	12.7		11.0	11.9		10.7	
42.0			14.1		10.3	11.7		9.9	11.0		10.2	
44.0			12.9			10.8			10.2		9.1	10.6
46.0						9.9			9.4			9.4
48.0									8.6			8.6
50.0												7.9
θ(°)	8~64	8~61	8~52	8~60	8~69	8~53	8~58	8~57	8~53	8~65	8~62	8~54
標準フック				35t								
フック質量				950kg								
標準巻掛本数	3						2					

カウンタウエイト 118t、アウトリガ張出幅 8.5m

PS+ブーム+2.5m+34.0mLJ

単位:t

ブーム長さ ブーム起伏角 作業半径 (m)	35.3m			40.4m			45.4m			50.5m			55.6m		
	83°	75°	68°	83°	75°	68°	83°	75°	68°	83°	75°	68°	83°	75°	68°
18.0	27.8														
20.0	24.4			19.8											
22.0	22.8			19.3			15.6								
24.0	21.2			18.9			15.2			11.5				7.9	
26.0	19.4			18.4			15.0			11.4				7.7	
28.0	17.7	21.2		17.6			14.7			11.4				7.7	
30.0	16.1	19.5		16.1	17.5		14.4			11.1				7.7	
32.0	14.6	18.0		14.6	16.3		13.8	14.4		11.0				7.7	
34.0	12.9	16.6		13.3	15.0		12.7	14.1		10.7	11.1			7.7	
36.0		15.3	17.5	12.0	13.8		11.4	13.2		10.6	10.8			7.5	7.2
38.0		14.0	16.2		12.7	13.6		12.0			10.5			7.2	7.2
40.0		12.8	15.0		11.7	12.6		11.0			10.5			7.0	
42.0		11.4	13.9		10.6	11.7		10.1	11.0		10.1			7.0	
44.0			12.9			10.8		9.1	10.1		9.3	10.3		7.0	
46.0			11.8			10.0			9.4		8.3	9.3		6.6	6.9
48.0						9.1			8.6			8.6			6.7
50.0									7.8			7.9			6.4
54.0															6.4
θ(°)	8~56	8~64	8~54	8~62	8~55	8~55	8~59	8~59	8~56	8~57	8~64	8~45	8~63	8~55	8~58
標準フック				35t						12.2t					
フック質量				950kg						440kg					
標準巻掛本数	3						2						1		

カウンタウエイト 118t、アウトリガ張出幅 8.5m

PS+ブーム+2.5m+40.0mLJ

単位:t

ブーム長さ ブーム起伏角 作業半径 (m)	35.3m			40.4m			45.4m			50.5m			55.6m		
	83°	75°	68°	83°	75°	68°	83°	75°	68°	83°	75°	68°	83°	75°	68°
20.0	20.8														
22.0	20.4			17.2											
24.0	20.0			16.8			13.4								
26.0	19.6			16.5			13.2			10.3				8.2	
28.0	18.7			16.2			13.1			10.3				8.0	
30.0	17.7	19.1		15.9			13.0			10.2				7.8	
32.0	16.7	18.8		15.6			12.8			10.0				7.7	
34.0	15.7	18.1		15.0	15.4		12.7			9.8				7.5	
36.0	14.8	17.0		14.1	15.0		12.4	12.6		9.7				7.3	
38.0	14.0	15.8		13.0	14.2		11.3	12.1		9.6	9.7			7.2	7.3
40.0	12.9	14.7	15.3	11.9	13.2		10.3	11.4		9.4	9.5			7.0	7.1
42.0		13.6	14.6	10.8	12.3	12.7	9.3	10.5		9.2	9.4			6.9	6.9
44.0		12.6	13.7		11.5	12.1		9.7	10.2		9.2			6.7	6.8
46.0		11.5	12.8		10.6	11.4		9.0	9.5		8.8			6.6	
48.0		10.4	11.9		9.8	10.7		8.3	8.9		8.3	8.8		6.5	
50.0			11.0			10.0		7.5	8.3		7.6	8.1		6.3	6.3
54.0									7.1			7.0			6.0
58.0												5.9			5.8
θ(°)	8~59	8~65	8~45	8~64	8~57	8~39	8~61	8~60	8~46	8~59	8~54	8~58	8~65	8~49	8~47
標準フック				35t						12.2t					
フック質量				950kg						440kg					
標準巻掛本数				2									1		

カウンタウエイト 118t、アウトリガ張出幅 8.5m

PS+ブーム+2.5m+46.0m(ヘビー)LJ

単位:t

ブーム長さ ブーム起伏角 作業半径(m)	35.3m			40.4m			45.4m			50.5m			55.6m		
	83°	75°	68°	83°	75°	68°	83°	75°	68°	83°	75°	68°	83°	75°	68°
22.0	17.1														
24.0	16.8			14.0											
26.0	16.5			13.8			12.0			9.2					
28.0	16.2			13.7			11.8			9.0			6.6		
30.0	16.0			13.5			11.6			8.9			6.5		
32.0	15.7			13.3			11.5			8.7			6.3		
34.0	15.4	15.4		13.2			11.4			8.6			6.2		
36.0	14.8	15.2		13.0	13.1		11.2			8.5			6.1		
38.0	13.7	14.4		12.2	12.9		11.0	11.2		8.3			6.0		
40.0	12.7	13.5		11.3	12.0		10.6	10.9		8.2	8.2		5.9		
42.0	11.8	12.6	12.7	10.5	11.2		9.7	10.2		8.1	8.1		5.8	5.7	
44.0	10.9	11.8	12.1	9.6	10.4		8.9	9.5		7.9	7.9		5.7	5.6	
46.0	9.9	11.0	11.5	8.8	9.7	9.9	8.2	8.9		7.8	7.8		5.6	5.5	
48.0		10.2	10.7		9.0	9.4	7.5	8.3	8.5	7.5	7.7		5.5	5.4	
50.0		9.5	10.1		8.4	8.8		7.7	7.9		7.5	7.5	5.3	5.3	
54.0			8.8		7.1	7.7		6.6	6.9		6.5	6.7	5.0	5.0	
58.0								6.6	6.0		5.4	5.8		4.8	4.8
62.0												5.0			4.6
66.0															3.9
θ(°)	8~60	8~49	8~41	8~58	8~58	8~47	8~63	8~53	8~41	8~61	8~66	8~48	8~66	8~58	8~59
標準フック	35t						12.2t								
フック質量	950kg						440kg								
標準巻掛本数	2						1								

カウンタウエイト 118t、アウトリガ張出幅 8.5m

PS+ブーム+2.5m+52.0m(ヘビー)LJ

単位:t

ブーム長さ ブーム起伏角 作業半径(m)	35.3m			40.4m			45.4m			50.5m			55.6m		
	83°	75°	68°	83°	75°	68°	83°	75°	68°	83°	75°	68°	83°	75°	68°
24.0	15.5														
26.0	15.3														
28.0	15.1			12.9			10.5			7.8					
30.0	14.9			12.7			10.3			7.7			5.4		
32.0	14.8			12.6			10.2			7.5			5.4		
34.0	14.6			12.4			10.1			7.4			5.3		
36.0	14.5	14.5		12.3			10.0			7.3			5.2		
38.0	14.4	13.9		12.0			9.9			7.2			5.1		
40.0	14.1	13.3		11.7	11.4		9.7	9.8		7.1			5.0		
42.0	13.2	12.8		10.9	10.9		9.6	9.7		7.0	7.0		4.9		
44.0	12.3	12.2		10.1	10.4		9.4	9.4		7.0	6.9		4.9	4.8	
46.0	11.5	11.7	10.3	9.4	9.9		8.7	9.0		6.9	6.8		4.8	4.7	
48.0	10.6	11.3	9.8	8.7	9.3		8.1	8.4		6.8	6.7		4.7	4.6	
50.0	9.8	10.8	9.4	8.1	8.7	7.7	7.4	7.9		6.7	6.6		4.7	4.5	
54.0		9.5	8.7		7.6	7.1	6.2	6.8	7.0	6.3	6.4	6.1	4.5	4.4	
58.0		8.1	8.0		6.5	6.5		5.9	6.1		5.8	5.4		4.2	4.1
62.0			7.0			5.8		5.0	5.3		4.9	4.6		4.0	3.9
66.0									4.6			3.9			3.4
70.0															2.8
θ(°)	8~56	8~56	8~48	8~55	8~52	8~43	8~64	8~62	8~49	8~62	8~57	8~43	8~60	8~52	8~50
標準フック	35t						12.2t								
フック質量	950kg						440kg								
標準巻掛本数	2						1								

カウンタウエイト 118t、アウトリガ張出幅 8.5m

PS+ブーム+2.5m+58.0m(ヘビー)LJ

単位:t

ブーム長さ ブーム起伏角 作業半径(m)	35.3m			40.4m			45.4m			50.5m			55.6m		
	83°	75°	68°	83°	75°	68°	83°	75°	68°	83°	75°	68°	83°	75°	68°
26.0	14.1														
28.0	13.9			11.2											
30.0	13.8			11.1			8.7								
32.0	13.6			11.0			8.6			6.1			4.1		
34.0	13.4			10.8			8.5			6.0			4.0		
36.0	13.3			10.7			8.3			6.0			3.9		
38.0	13.2	13.2		10.6			8.3			5.9			3.8		
40.0	12.8	12.7		10.5			8.2			5.8			3.8		
42.0	12.1	12.1		10.2	10.3		8.1			5.7			3.7		
44.0	11.4	11.5		10.0	10.1		8.0	8.0		5.7			3.7		
46.0	10.7	11.0		9.3	9.5		7.9	7.9		5.6	5.5		3.6		
48.0	10.0	10.3	9.1	8.7	8.9		7.8	7.7		5.5	5.5		3.6	3.5	
50.0	9.3	9.7	8.7	8.1	8.3		7.4	7.6		5.5	5.4		3.6	3.4	
54.0	8.0	8.5	7.9	7.0	7.3	6.6	6.3	6.5		5.4	5.2		3.4	3.3	
58.0	6.8	7.5	7.1	5.9	6.4	6.1	5.4	5.7		5.0	5.2	4.0	3.4	3.2	
62.0		6.4	6.2		5.5	5.3		4.9	4.2		4.8	3.2		3.1	2.4
66.0			5.4		4.6	4.5		4.1	3.4		4.0	2.6		3.0	1.8
70.0					3.8				2.8			2.0		2.9	
θ(°)	8~63	8~52	8~44	8~61	8~60	8~50	8~59	8~56	8~44	8~58	8~52	8~40	8~57	8~60	8~29
標準フック	35t						12.2t								
フック質量	950kg						440kg								
標準巻掛本数	2						1								

カウンタウエイト 118t、アウトリガ張出幅 8.5m

PS+ブーム+2.5m+64.0m(ヘビー)LJ

単位:t

ブーム長さ ブーム起伏角 作業半径(m)	35.3m			40.4m			45.4m			50.5m			55.6m		
	83°	75°	68°	83°	75°	68°	83°	75°	68°	83°	75°	68°	83°	75°	
28.0	12.3														
30.0	12.1			9.6											
32.0	12.0			9.5			7.4			5.1					
34.0	11.9			9.4			7.3			5.0			3.1		
36.0	11.7			9.3			7.2			5.0			3.1		
38.0	11.6			9.2			7.1			4.9			3.0		
40.0	11.5			9.1			7.0			4.8			3.0		
42.0	11.4	10.4		9.0			7.0			4.8			2.9		
44.0	11.3	10.0		8.9	8.6		6.9			4.7			2.9		
46.0	11.0	9.5		8.8	8.2		6.8	6.8		4.7			2.9		
48.0	10.6	9.1		8.7	7.9		6.8	6.7		4.6	4.5		2.8		
50.0	10.1	8.7		8.3	7.5		6.7	6.5		4.6	4.5		2.8	2.6	
54.0	9.1	8.0	6.6	7.2	6.9		6.4	6.0		4.5	4.4		2.7	2.5	
58.0	7.9	7.4	6.0	6.3	6.4	4.9	5.7	5.5		4.4	4.2		2.6	2.5	
62.0	6.8	6.9	5.3	5.3	5.7	4.3	4.8	5.0	3.1	4.4	4.2	2.5	2.6	2.4	
66.0		6.4	4.5		4.9	3.5		4.3	2.5	4.0	4.1	1.9	2.6	2.3	
70.0		5.6	3.9		4.2	2.9		3.6	1.9		3.5		2.3	2.3	
74.0			3.2			2.3		3.0			2.9			2.3	
θ(°)	8~59	8~58	8~50	8~58	8~55	8~45	8~56	8~64	8~44	8~64	8~59	8~25	8~63	8~55	
標準フック	35t						12.2t								
フック質量	950kg						440kg								
標準巻掛本数	2						1								

PS+ラフィングジブ

カウンタウエイト 118t、アウトリガ張出幅 8.5m

PS+ブーム+2.5m+70.0mLJ

単位:t

ブーム長さ ブーム起伏角 作業半径(m)	35.3m			40.4m			45.4m			50.5m	
	83°	75°	68°	83°	75°	68°	83°	75°	68°	83°	75°
32.0	10.3			8.0			6.1				
34.0	10.2			8.0			6.0			3.9	
36.0	10.1			7.9			5.9			3.8	
38.0	10.0			7.8			5.8			3.8	
40.0	9.9			7.8			5.8			3.8	
42.0	9.8			7.7			5.8			3.8	
44.0	9.7			7.6			5.7			3.8	
46.0	9.7	8.4		7.6	6.7		5.6			3.7	
48.0	9.6	8.0		7.5	6.4		5.6	5.6		3.7	
50.0	9.3	7.7		7.1	5.9		5.5	5.4		3.6	3.5
54.0	8.6	7.1		6.4	5.4		5.4	5.0		3.6	3.4
58.0	8.0	6.5	5.2	5.5	4.9	3.5	5.0	4.5	2.7	3.5	3.3
62.0	7.1	6.0	4.7	4.7	4.5	2.8	4.2	4.1	2.1	3.5	3.3
66.0	6.2	5.6	4.0	4.0	4.2	2.2	3.5	3.6	1.5	3.4	3.0
70.0	5.2	5.2	3.4								
74.0		4.5	2.8		3.6	1.6					2.4
78.0			2.2		3.0			2.5			1.9
θ(°)	8~65	8~54	8~46	8~63	8~61	8~35	8~62	8~57	8~27	8~60	8~54
標準フック	12.2t										
フック質量	440kg										
標準巻掛本数	1										

カウンタウエイト 118t、アウトリガ張出幅 8.5m

PS+ブーム+2.5m+46.0m(ライト)LJ

単位:t

ブーム長さ ブーム起伏角 作業半径(m)	35.3m			40.4m			45.4m			50.5m			55.6m		
	83°	75°	68°	83°	75°	68°	83°	75°	68°	83°	75°	68°	83°	75°	68°
22.0	17.7														
24.0	17.1														
26.0	16.4			14.2			12.6			9.3					
28.0	15.5			13.9			12.5			9.1			6.8		
30.0	14.5			13.7			12.3			9.0			6.7		
32.0	13.7			13.2			12.1			8.8			6.5		
34.0	12.8	14.9		12.6			11.9			8.7			6.4		
36.0	12.0	14.1		12.0	13.3		11.5			8.6			6.3		
38.0	11.3	13.2		11.3	13.0		11.1	11.9		8.4			6.2		
40.0	10.7	12.4		10.7	12.3		10.6	11.7		8.3	8.4		6.1		
42.0	10.1	11.7	13.2	10.1	11.6		10.2	11.4		8.2	8.2		6.0	5.9	
44.0	9.5	11.0	12.5	9.6	10.8		9.7	10.8		8.1	8.1		5.9	5.8	
46.0	9.0	10.4	11.8	9.1	10.1	10.2	9.1	10.1		7.9	8.0		5.7	5.7	
48.0		9.8	11.1		9.4	9.7	8.4	9.4	9.2	7.7	7.8		5.6	5.6	
50.0		9.3	10.5		8.7	9.2		8.8	8.8		7.7	7.7	5.5	5.5	
54.0			9.3		7.4	8.1		7.6	8.1		6.8	7.1	5.3	5.2	
58.0					7.0				7.2		5.6	6.2	5.0	5.0	
62.0												5.3			4.8
66.0															4.4
θ(°)	8~60	8~49	8~41	8~58	8~58	8~47	8~63	8~53	8~41	8~61	8~66	8~48	8~66	8~58	8~59
標準フック	35t						12.2t								
フック質量	950kg						440kg								
標準巻掛本数	2						1								

カウンタウエイト 118t、アウトリガ張出幅 8.5m

PS+ブーム+2.5m+52.0m(ライト)LJ

単位:t

ブーム長さ ブーム起伏角 作業半径(m)	35.3m			40.4m			45.4m			50.5m			55.6m		
	83°	75°	68°	83°	75°	68°	83°	75°	68°	83°	75°	68°	83°	75°	68°
26.0	14.0						10.2			7.8					
28.0	13.3			12.0			10.2			7.8					
30.0	12.7			11.6			10.1			7.6			5.6		
32.0	12.0			11.1			9.8			7.5			5.5		
34.0	11.4			10.5			9.6			7.4			5.4		
36.0	10.7			10.0			9.2			7.3			5.3		
38.0	10.1	11.7		9.5			8.9			7.2			5.2		
40.0	9.5	11.0		9.0	10.4		8.5	9.4		7.1			5.1		
42.0	9.0	10.4		8.5	9.9		8.2	9.2		7.1	7.0		5.1		
44.0	8.5	9.8		8.0	9.4		7.8	8.8		6.9	7.0		5.0	4.9	
46.0	8.0	9.3	10.4	7.6	8.9		7.4	8.5		6.7	6.9		4.9	4.8	
48.0	7.6	8.7	9.9	7.2	8.4		7.1	8.2		6.5	6.8		4.9	4.8	
50.0	7.2	8.3	9.3	6.8	8.0	8.1	6.8	7.8		6.3	6.7		4.8	4.7	
54.0		7.4	8.3		7.2	7.5	6.1	7.1	7.3	5.8	6.5	6.5	4.6	4.5	
58.0		6.7	7.5		6.4	7.0		6.2	6.4	6.0	6.1		4.4	4.3	
62.0			6.7		6.3			5.2	5.6	5.2	5.3		4.2	4.1	
66.0								4.9			4.6				4.0
70.0															3.5
θ(°)	8~56	8~56	8~48	8~55	8~52	8~43	8~64	8~62	8~49	8~62	8~57	8~43	8~60	8~52	8~50
標準フック	35t						12.2t								
フック質量	950kg						440kg								
標準巻掛本数	2						1								

カウンタウエイト 118t、アウトリガ張出幅 8.5m

PS+ブーム+2.5m+58.0m(ライト)LJ

単位:t

ブーム長さ ブーム起伏角 作業半径(m)	35.3m			40.4m			45.4m			50.5m			55.6m		
	83°	75°	68°	83°	75°	68°	83°	75°	68°	83°	75°	68°	83°	75°	68°
28.0	14.1														
28.0	13.9			11.3											
30.0	13.8			11.2			8.8								
32.0	13.6			11.1			8.7			6.4			4.4		
34.0	13.4			11.0			8.6			6.3			4.3		
36.0	13.1			10.8			8.5			6.2			4.2		
38.0	12.7	13.3		10.7			8.5			6.1			4.1		
40.0	12.2	13.0		10.6			8.4			6.1			4.1		
42.0	11.8	12.5		10.5	10.5		8.3			6.0			4.0		
44.0	11.4	12.0		10.3	10.4		8.2	8.2		5.9			4.0		
46.0	10.9	11.4		9.7	10.0		8.1	8.1		5.8	5.8		3.9		
48.0	10.3	10.7		9.0	9.3		8.1	8.0		5.8	5.7		3.9	3.7	
50.0	9.6	10.1	9.1	8.4	8.7		7.7	7.9		5.7	5.7		3.8	3.7	
54.0	8.4	8.9	8.4	7.3	7.7	7.2	6.7	6.9		5.6	5.5		3.7	3.6	
58.0	7.1	7.8	7.7	6.2	6.7	6.6	5.7	6.0	5.6	5.5	5.4	4.6	3.7	3.5	
62.0		6.8	6.9		5.8	5.9		5.2	4.9		5.1	3.9		3.4	3.2
66.0			6.1		4.9	5.1		4.5	4.1		4.4	3.2		3.3	2.5
74.0						4.4			3.5			2.6		3.2	2.0
θ(°)	8~63	8~52	8~44	8~61	8~60	8~50	8~59	8~56	8~44	8~58	8~52	8~50	8~57	8~60	8~45
標準フック	35t						12.2t								
フック質量	950kg						440kg								
標準巻掛本数	2						1								

カウンタウエイト 118t、アウトリガ張出幅 8.5m

PS+ブーム+2.5m+64.0m(ライト)LJ

単位:t

ブーム長さ ブーム起伏角 作業半径(m)	35.3m			40.4m			45.4m			50.5m			55.6m		
	83°	75°	68°	83°	75°	68°	83°	75°	68°	83°	75°	68°	83°	75°	68°
28.0	12.2														
30.0	12.1			9.5											
32.0	11.7			9.5			7.4								
34.0	11.4			9.4			7.3			5.1			3.4		
36.0	11.0			9.3			7.3			5.0			3.3		
38.0	10.6			9.2			7.2			5.0			3.3		
40.0	10.2			9.0			7.1			5.0			3.2		
42.0	9.8	10.8		8.8			7.1			5.0			3.2		
44.0	9.4	10.4		8.6	9.0		7.0			4.9			3.2		
46.0	9.0	10.0		8.3	8.8		6.9	6.9		4.8	4.7		3.1		
48.0	8.6	9.6		8.1	8.4		6.9	6.8		4.8	4.7		3.1		
50.0	8.3	9.2		7.8	8.1		6.8	6.8		4.7	4.7		3.1	2.9	
54.0	7.6	8.5	7.2	7.3	7.4		6.6	6.5		4.7	4.6		2.9	2.8	
58.0	7.0	7.8	6.6	6.6	6.8	5.4	6.0	6.0		4.6	4.5		2.9	2.7	
62.0	6.4	7.1	6.1	5.6	6.0	5.0	5.3	3.8	4.6	4.4	3.0		2.9	2.7	
66.0		6.6	5.3		5.2	4.2		4.6	3.2	4.3	4.3	2.4	2.8	2.6	1.7
70.0		6.1	4.6		4.5	3.6		4.0	2.5	4.6	3.8	1.9	2.6	2.6	
74.0			4.0			3.0		3.3	2.0		3.2			2.5	
78.0									1.5						
θ(°)	8~59	8~58	8~50	8~58	8~55	8~45	8~56	8~64	8~51	8~64	8~59	8~31	8~63	8~55	8~23
標準フック	35t						12.2t								
フック質量	950kg						440kg								
標準巻掛本数	2						1								

PS+ラフィングジブ

カウンタウエイト 118t、アウトリガ張出幅 8.0m
PS+ブーム+2.5m+20.3mLJ

ブーム長さ ブーム起伏角 作業半径 (m)	35.3m			40.4m			45.4m		
	83°	75°	68°	83°	75°	68°	83°	75°	68°
16.0	39.8								
18.0	35.5			31.1					
20.0	31.7			27.6			26.7		
22.0	28.0			22.0			21.5		
24.0		30.1					18.5		
26.0		27.2			21.4				
28.0		21.3			19.0				
30.0			22.8		16.5			16.4	
32.0			20.3						
34.0					15.9				
36.0									14.0
θ (°)	18~58	18~57	18~47	18~54	18~67	18~48	18~64	18~52	18~49
標準フック	80t			35t					
フック質量	1550kg			950kg					
標準巻掛本数	4			3					

カウンタウエイト 118t、アウトリガ張出幅 8.0m
PS+ブーム+2.5m+32.3mLJ

ブーム長さ ブーム起伏角 作業半径 (m)	35.3m			40.4m			45.4m			50.5m		
	83°	75°	68°	83°	75°	68°	83°	75°	68°	83°	75°	68°
18.0	30.8											
20.0	30.3			20.8								
22.0	29.4			20.3			16.5			12.5		
24.0	26.9			19.9			16.1			12.1		
26.0	22.4			19.0			15.8			11.9		
28.0	20.4	22.8		17.5			15.6			11.7		
30.0	18.6	20.9		16.0	17.7		15.3			11.6		
32.0	16.9	19.3		14.5	16.2		13.9	15.1		11.3		
34.0	15.2	17.8	19.2	13.1	15.0		12.5	14.2		11.0	11.5	
36.0		16.3	17.8		13.8		13.0			11.0	11.2	
38.0		14.9	16.5		12.6	13.7		12.0			10.9	
40.0		13.4	15.3		11.5	12.7		11.0	11.9		10.7	
42.0			14.1		10.3	11.7		9.9	11.0		10.2	
44.0			12.9			10.8			10.2		9.1	10.6
46.0						9.9			9.4			9.4
48.0									8.6			8.6
50.0												7.9
θ (°)	8~64	8~61	8~52	8~60	8~69	8~53	8~58	8~57	8~53	8~65	8~62	8~54
θ (°)性能表示範囲	8~61	8~58	8~49	8~58	8~63	8~49	8~56	8~54	8~50	8~62	8~58	8~51
標準フック				35t								
フック質量				950kg								
標準巻掛本数	3						2					

カウンタウエイト 118t、アウトリガ張出幅 8.0m
PS+ブーム+2.5m+34.0mLJ

ブーム長さ ブーム起伏角 作業半径 (m)	35.3m			40.4m			45.4m			50.5m			55.6m		
	83°	75°	68°	83°	75°	68°	83°	75°	68°	83°	75°	68°	83°	75°	68°
18.0	27.8														
20.0	24.4			19.8											
22.0	22.8			19.3			15.6								
24.0	21.2			18.9			15.2			11.5				7.9	
26.0	19.4			18.4			15.0			11.4				7.7	
28.0	17.7	21.2		17.6			14.7			11.4				7.7	
30.0	16.1	19.5		16.1	17.5		14.4			11.1				7.7	
32.0	14.6	18.0		14.6	16.3		13.8	14.4		11.0				7.7	
34.0	12.9	16.6		13.3	15.0		12.7	14.1		10.7	11.1			7.7	
36.0		15.3	17.5	12.0	13.8		11.4	13.2		10.6	10.8			7.5	7.2
38.0		14.0	16.2		12.7	13.6		12.0			10.5			7.2	7.2
40.0		12.8	15.0		11.7	12.6		11.0			10.5			7.0	
42.0		11.4	13.9		10.6	11.7		10.1	11.0		10.1			7.0	
44.0			12.9			10.8		9.1	10.1		9.3	10.3		7.0	
46.0			11.8			10.0			9.4		8.3	9.3		6.6	6.9
48.0						9.1			8.6			8.6			6.7
50.0									7.8			7.9			6.4
54.0															6.4
θ (°)	8~56	8~64	8~54	8~62	8~55	8~55	8~59	8~59	8~56	8~57	8~64	8~45	8~63	8~55	8~58
θ (°)性能表示範囲															
標準フック				35t						12.2t					
フック質量				950kg						440kg					
標準巻掛本数	3						2			1					

カウンタウエイト 118t、アウトリガ張出幅 8.0m
PS+ブーム+2.5m+40.0mLJ

ブーム長さ ブーム起伏角 作業半径 (m)	35.3m			40.4m			45.4m			50.5m			55.6m		
	83°	75°	68°	83°	75°	68°	83°	75°	68°	83°	75°	68°	83°	75°	68°
20.0	20.8														
22.0	20.4			17.2											
24.0	20.0			16.8			13.4								
26.0	19.6			16.5			13.2			10.3				8.2	
28.0	18.7			16.2			13.1			10.3				8.0	
30.0	17.7	19.1		15.9			13.0			10.2				7.8	
32.0	16.7	18.8		15.6			12.8			10.0				7.7	
34.0	15.7	18.1		15.0	15.4		12.7			9.8				7.5	
36.0	14.8	17.0		14.1	15.0		12.4	12.6		9.7				7.3	
38.0	14.0	15.8		13.0	14.2		11.3	12.1		9.6	9.7			7.2	7.3
40.0	12.9	14.7	15.3	11.9	13.2		10.3	11.4		9.4	9.5			7.0	7.1
42.0		13.6	14.6	10.8	12.3	12.7	9.3	10.5		9.2	9.4			6.9	6.9
44.0		12.6	13.7		11.5	12.1		9.7	10.2		9.2			6.7	6.8
46.0		11.5	12.8		10.6	11.4		9.0	9.5		8.8			6.6	
48.0		10.4	11.9		9.8	10.7		8.3	8.9		8.3	8.8		6.5	
50.0			11.0			10.0		7.5	8.3		7.6	8.1		6.3	6.3
54.0									7.1			7.0			6.0
58.0												5.9			5.8
θ (°)	8~59	8~65	8~45	8~64	8~57	8~39	8~61	8~60	8~46	8~59	8~54	8~58	8~65	8~49	8~47
θ (°)性能表示範囲	8~57	8~61	8~44	8~62	8~55	8~38	8~59	8~58	8~44	8~57	8~52	8~54	8~62	8~48	8~45
標準フック				35t						12.2t					
フック質量				950kg						440kg					
標準巻掛本数				2						1					

カウンタウエイト 118t、アウトリガ張出幅 8.0m

PS+ブーム+2.5m+46.0m(ヘビー)LJ

単位:t

ブーム長さ ブーム起伏角 作業半径(m)	35.3m			40.4m			45.4m			50.5m			55.6m		
	83°	75°	68°	83°	75°	68°	83°	75°	68°	83°	75°	68°	83°	75°	68°
22.0	17.1														
24.0	16.8			14.0											
26.0	16.5			13.8			12.0			9.2					
28.0	16.2			13.7			11.8			9.0			6.6		
30.0	16.0			13.5			11.6			8.9			6.5		
32.0	15.7			13.3			11.5			8.7			6.3		
34.0	15.4	15.4		13.2			11.4			8.6			6.2		
36.0	14.8	15.2		13.0	13.1		11.2			8.5			6.1		
38.0	13.7	14.4		12.2	12.9		11.0	11.2		8.3			6.0		
40.0	12.7	13.5		11.3	12.0		10.6	10.9		8.2	8.2		5.9		
42.0	11.8	12.6	12.7	10.5	11.2		9.7	10.2		8.1	8.1		5.8	5.7	
44.0	10.9	11.8	12.1	9.6	10.4		8.9	9.5		7.9	7.9		5.7	5.6	
46.0	9.9	11.0	11.5	8.8	9.7	9.9	8.2	8.9		7.8	7.8		5.6	5.5	
48.0		10.2	10.7		9.0	9.4	7.5	8.3	8.5	7.5	7.7		5.5	5.4	
50.0		9.5	10.1		8.4	8.8		7.7	7.9		7.5	7.5	5.3	5.3	
54.0			8.8		7.1	7.7		6.6	6.9		6.5	6.7	5.0	5.0	
58.0								6.6	6.0		5.4	5.8	4.8	4.8	
62.0												5.0			4.3
66.0															3.6
θ(°)	8~60	8~49	8~41	8~58	8~58	8~47	8~63	8~53	8~41	8~61	8~66	8~48	8~66	8~58	8~59
標準フック	35t						12.2t								
フック質量	950kg						440kg								
標準巻掛本数	2						1								

カウンタウエイト 118t、アウトリガ張出幅 8.0m

PS+ブーム+2.5m+52.0m(ヘビー)LJ

単位:t

ブーム長さ ブーム起伏角 作業半径(m)	35.3m			40.4m			45.4m			50.5m			55.6m		
	83°	75°	68°	83°	75°	68°	83°	75°	68°	83°	75°	68°	83°	75°	68°
24.0	15.5														
26.0	15.3														
28.0	15.1			12.9			10.5			7.8					
30.0	14.9			12.7			10.3			7.7			5.4		
32.0	14.8			12.6			10.2			7.5			5.4		
34.0	14.6			12.4			10.1			7.4			5.3		
36.0	14.5	14.5		12.3			10.0			7.3			5.2		
38.0	14.4	13.9		12.0			9.9			7.2			5.1		
40.0	14.1	13.3		11.7	11.4		9.7	9.8		7.1			5.0		
42.0	13.2	12.8		10.9	10.9		9.6	9.7		7.0	7.0		4.9		
44.0	12.3	12.2		10.1	10.4		9.4	9.4		7.0	6.9		4.9	4.8	
46.0	11.5	11.7	10.3	9.4	9.9		8.7	9.0		6.9	6.8		4.8	4.7	
48.0	10.6	11.3	9.8	8.7	9.3		8.1	8.4		6.8	6.7		4.7	4.6	
50.0	9.8	10.8	9.4	8.1	8.7	7.7	7.4	7.9		6.7	6.6		4.7	4.5	
54.0		9.5	8.6		7.6	7.1	6.2	6.8	7.0	6.3	6.4	6.0	4.5	4.4	
58.0		8.1	7.6		6.5	6.2		5.9	6.1		5.8	5.1	4.2	4.1	
62.0			6.7			5.4		5.0	5.2		4.9	4.3	4.0	3.8	
66.0									4.5			3.6		3.1	
70.0														2.5	
θ(°)	8~56	8~56	8~48	8~55	8~52	8~43	8~64	8~62	8~49	8~62	8~57	8~43	8~60	8~52	8~50
標準フック	35t						12.2t								
フック質量	950kg						440kg								
標準巻掛本数	2						1								

カウンタウエイト 118t、アウトリガ張出幅 8.0m

PS+ブーム+2.5m+58.0m(ヘビー)LJ

単位:t

ブーム長さ ブーム起伏角 作業半径(m)	35.3m			40.4m			45.4m			50.5m			55.6m		
	83°	75°	68°	83°	75°	68°	83°	75°	68°	83°	75°	68°	83°	75°	68°
26.0	14.1														
28.0	13.9			11.2											
30.0	13.8			11.1			8.7								
32.0	13.6			11.0			8.6			6.1			4.1		
34.0	13.4			10.8			8.5			6.0			4.0		
36.0	13.3			10.7			8.3			6.0			3.9		
38.0	13.2	13.2		10.6			8.3			5.9			3.8		
40.0	12.8	12.7		10.5			8.2			5.8			3.8		
42.0	12.1	12.1		10.2	10.3		8.1			5.7			3.7		
44.0	11.4	11.5		10.0	10.1		8.0	8.0		5.7			3.7		
46.0	10.7	11.0		9.3	9.5		7.9	7.9		5.6	5.5		3.6		
48.0	10.0	10.3	9.1	8.7	8.9		7.8	7.7		5.5	5.5		3.6	3.5	
50.0	9.3	9.7	8.7	8.1	8.3		7.4	7.6		5.5	5.4		3.6	3.4	
54.0	8.0	8.5	7.8	7.0	7.3	6.6	6.3	6.5		5.4	5.2		3.4	3.3	
58.0	6.8	7.5	6.8	5.9	6.4	5.7	5.4	5.7	4.6	5.2	5.1	3.6	3.4	3.2	
62.0		6.4	5.9		5.5	4.9		4.9	3.8		4.8	2.9	3.1	2.1	
66.0			5.1		4.6	4.2		4.1	3.1		4.0	2.2	3.0	1.5	
70.0					3.5				2.5			1.7	2.9		
θ(°)	8~63	8~52	8~44	8~61	8~60	8~50	8~59	8~56	8~44	8~58	8~52	8~40	8~57	8~60	8~29
標準フック	35t						12.2t								
フック質量	950kg						440kg								
標準巻掛本数	2						1								

カウンタウエイト 118t、アウトリガ張出幅 8.0m

PS+ブーム+2.5m+64.0m(ヘビー)LJ

単位:t

ブーム長さ ブーム起伏角 作業半径(m)	35.3m			40.4m			45.4m			50.5m			55.6m	
	83°	75°	68°	83°	75°	68°	83°	75°	68°	83°	75°	68°	83°	75°
28.0	12.3													
30.0	12.1			9.6										
32.0	12.0			9.5			7.4			5.1				
34.0	11.9			9.4			7.3			5.0			3.1	
36.0	11.7			9.3			7.2			5.0			3.1	
38.0	11.6			9.2			7.1			4.9			3.0	
40.0	11.5			9.1			7.0			4.8			3.0	
42.0	11.4	10.4		9.0			7.0			4.8			2.9	
44.0	11.3	10.0		8.9	8.6		6.9			4.7			2.9	
46.0	11.0	9.5		8.8	8.2		6.8	6.8		4.7			2.9	
48.0	10.6	9.1		8.7	7.9		6.8	6.7		4.6	4.5		2.8	
50.0	10.1	8.7		8.3	7.5		6.7	6.5		4.6	4.5		2.8	2.6
54.0	9.1	8.0	6.6	7.2	6.9		6.4	6.0		4.5	4.4		2.7	2.5
58.0	7.9	7.4	5.8	6.3	6.4	4.7	5.7	5.5		4.4	4.3		2.6	2.5
62.0	6.8	6.9	4.9	5.3	5.7	3.9	4.8	5.0	2.8	4.4	4.2	2.2	2.6	2.4
66.0		6.1	4.2		4.9	3.2		4.3	2.1	4.0	4.1	1.6	2.6	2.3
70.0		5.3	3.5		4.2	2.6		3.6	1.6		3.4		2.3	
74.0			2.9			2.0		3.0			2.8			2.2
θ(°)	8~59	8~58	8~50	8~58	8~55	8~45	8~56	8~64	8~34	8~64	8~59	8~25	8~63	8~55
標準フック	35t						12.2t							
フック質量	950kg						440kg							
標準巻掛本数	2						1							

PS+ラフィングジブ

カウンタウエイト 118t、アウトリガ張出幅 8.0m

PS+ブーム+2.5m+70.0mLJ

単位:t

ブーム長さ ブーム起伏角 作業半径(m)	35.3m			40.4m			45.4m			50.5m	
	83°	75°	68°	83°	75°	68°	83°	75°	68°	83°	75°
32.0	10.3			8.0			6.1				
34.0	10.2			8.0			6.0				3.9
36.0	10.1			7.9			5.9				3.8
38.0	10.0			7.8			5.8				3.8
40.0	9.9			7.8			5.8				3.8
42.0	9.8			7.7			5.8				3.8
44.0	9.7			7.6			5.7				3.8
46.0	9.7	8.4		7.6	6.7		5.6				3.7
48.0	9.6	8.0		7.5	6.4		5.5	5.6			3.7
50.0	9.3	7.7		7.1	5.9		5.5	5.4			3.6
54.0	8.6	7.1		6.4	5.4		5.4	5.0			3.6
58.0	8.0	6.5	5.2	5.5	4.9	3.1	5.0	4.5	2.4		3.5
62.0	7.1	6.0	4.4	4.7	4.5	2.5	4.2	4.1	1.8		3.5
66.0	6.2	5.6	3.7	4.0	3.9	1.9	3.5	3.4			3.4
70.0	5.2	4.8	3.1	3.3				2.8			2.7
74.0		4.2	2.5					2.7			2.2
78.0			1.9					2.3			1.6
θ(°)	8~65	8~54	8~46	8~63	8~61	8~30	8~62	8~57	8~22	8~60	8~54
標準フック	12.2t										
フック質量	440kg										
標準巻掛本数	1										

カウンタウエイト 118t、アウトリガ張出幅 8.0m

PS+ブーム+2.5m+46.0m(ライト)LJ

単位:t

ブーム長さ ブーム起伏角 作業半径(m)	35.3m			40.4m			45.4m			50.5m			55.6m		
	83°	75°	68°	83°	75°	68°	83°	75°	68°	83°	75°	68°	83°	75°	68°
22.0	17.7														
24.0	17.1														
26.0	16.4			14.2			12.6			9.3					
28.0	15.5			13.9			12.5			9.1			6.8		
30.0	14.5			13.7			12.3			9.0			6.7		
32.0	13.7			13.2			12.1			8.8			6.5		
34.0	12.8	14.9		12.6			11.9			8.7			6.4		
36.0	12.0	14.1		12.0	13.3		11.5			8.6			6.3		
38.0	11.3	13.2		11.3	13.0		11.1	11.9		8.4			6.2		
40.0	10.7	12.4		10.7	12.3		10.6	11.7		8.3	8.4		6.1		
42.0	10.1	11.7	13.2	10.1	11.6		10.2	11.4		8.2	8.2		6.0	5.9	
44.0	9.5	11.0	12.5	9.6	10.8		9.7	10.8		8.1	8.1		5.9	5.8	
46.0	9.0	10.4	11.8	9.1	10.1	10.2	9.1	10.1		7.9	8.0		5.7	5.7	
48.0		9.8	11.1		9.4	9.7	8.4	9.4	9.2	7.7	7.8		5.6	5.6	
50.0		9.3	10.5		8.7	9.2		8.8	8.8		7.7	7.7	5.5	5.5	
54.0			9.3		7.4	8.1		7.6	8.0		6.8	7.1	5.3	5.2	
58.0					7.0				7.1		5.6	6.2	5.0	5.0	
62.0											5.3				4.8
66.0															4.3
θ(°)	8~60	8~49	8~41	8~58	8~58	8~47	8~63	8~53	8~41	8~61	8~66	8~48	8~66	8~58	8~59
標準フック	35t												12.2t		
フック質量	950kg												440kg		
標準巻掛本数	2												1		

カウンタウエイト 118t、アウトリガ張出幅 8.0m

PS+ブーム+2.5m+52.0m(ライト)LJ

単位:t

ブーム長さ ブーム起伏角 作業半径(m)	35.3m			40.4m			45.4m			50.5m			55.6m		
	83°	75°	68°	83°	75°	68°	83°	75°	68°	83°	75°	68°	83°	75°	68°
26.0	14.0						10.2			7.8					
28.0	13.3			12.0			10.1			7.6			5.6		
30.0	12.7			11.6			9.8			7.5			5.5		
32.0	12.0			11.1			9.6			7.4			5.4		
34.0	11.4			10.5			9.6			7.3			5.3		
36.0	10.7			10.0			9.2			7.3			5.3		
38.0	10.1	11.7		9.5			8.9			7.2			5.2		
40.0	9.5	11.0		9.0	10.4		8.5	9.4		7.1			5.1		
42.0	9.0	10.4		8.5	9.9		8.2	9.2		7.1	7.0		5.1		
44.0	8.5	9.8		8.0	9.4		7.8	8.8		6.9	7.0		5.0	4.9	
46.0	8.0	9.3	10.4	7.6	8.9		7.4	8.5		6.7	6.9		4.9	4.8	
48.0	7.6	8.7	9.9	7.2	8.4		7.1	8.2		6.5	6.8		4.9	4.8	
50.0	7.2	8.3	9.3	6.8	8.0	8.1	6.8	7.8		6.3	6.7		4.8	4.7	
54.0		7.4	8.3		7.2	7.5	6.1	7.1	7.3	5.8	6.5	6.5	4.6	4.5	
58.0		6.7	7.5		6.4	6.8		6.2	6.4	6.0	5.8		4.4	4.3	
62.0			6.7		6.0			5.2	5.6	5.2	5.0		4.2	4.1	
66.0								4.9			4.3				3.7
70.0															3.2
θ(°)	8~56	8~56	8~48	8~55	8~52	8~43	8~64	8~62	8~49	8~62	8~57	8~43	8~60	8~52	8~50
標準フック	35t												12.2t		
フック質量	950kg												440kg		
標準巻掛本数	2												1		

カウンタウエイト 118t、アウトリガ張出幅 8.0m

PS+ブーム+2.5m+58.0m(ライト)LJ

単位:t

ブーム長さ ブーム起伏角 作業半径(m)	35.3m			40.4m			45.4m			50.5m			55.6m		
	83°	75°	68°	83°	75°	68°	83°	75°	68°	83°	75°	68°	83°	75°	68°
28.0	14.1														
28.0	13.9			11.3											
30.0	13.8			11.2			8.8								
32.0	13.6			11.1			8.7			6.4			4.4		
34.0	13.4			11.0			8.6			6.3			4.3		
36.0	13.1			10.8			8.5			6.2			4.2		
38.0	12.7	13.3		10.7			8.5			6.1			4.1		
40.0	12.2	13.0		10.6			8.4			6.1			4.1		
42.0	11.8	12.5		10.5	10.5		8.3			6.0			4.0		
44.0	11.4	12.0		10.3	10.4		8.2	8.2		5.9			4.0		
46.0	10.9	11.4		9.7	10.0		8.1	8.1		5.8	5.8		3.9		
48.0	10.3	10.7		9.0	9.3		8.1	8.0		5.8	5.7		3.9	3.7	
50.0	9.6	10.1	9.1	8.4	8.7		7.7	7.9		5.7	5.7		3.8	3.7	
54.0	8.4	8.9	8.4	7.3	7.7	7.2	6.7	6.9		5.6	5.5		3.7	3.6	
58.0	7.1	7.8	7.4	6.2	6.7	6.4	5.7	6.0	5.3	5.5	5.4	4.3	3.7	3.5	
62.0		6.8	6.5		5.8	5.6		5.2	4.5		5.1	3.5		3.4	2.8
66.0			5.7		4.9	4.8		4.5	3.8		4.4	2.9		3.3	2.2
70.0					4.1				3.2			2.3		3.2	1.7
74.0												1.8			
θ(°)	8~63	8~52	8~44	8~61	8~60	8~50	8~59	8~56	8~44	8~58	8~52	8~50	8~57	8~60	8~36
標準フック	35t												12.2t		
フック質量	950kg												440kg		
標準巻掛本数	2												1		

カウンタウエイト 118t、アウトリガ張出幅 8.0m

PS+ブーム+2.5m+64.0m(ライト)LJ

単位:t

ブーム長さ ブーム起伏角 作業半径(m)	35.3m			40.4m			45.4m			50.5m			55.6m	
	83°	75°	68°	83°	75°	68°	83°	75°	68°	83°	75°	68°	83°	75°
28.0	12.2													
30.0	12.1			9.5										
32.0	11.7			9.5			7.4							
34.0	11.4			9.4			7.3			5.1			3.4	
36.0	11.0			9.3			7.3			5.0			3.3	
38.0	10.6			9.2			7.2			5.0			3.3	
40.0	10.2			9.0			7.1			5.0			3.2	
42.0	9.8	10.8		8.8			7.1			5.0			3.2	
44.0	9.4	10.4		8.6	9.0		7.0			4.9			3.2	
46.0	9.0	10.0		8.3	8.8		6.9	6.9		4.8	4.7		3.1	
48.0	8.6	9.6		8.1	8.4		6.9	6.8		4.8	4.7		3.1	
50.0	8.3	9.2		7.8	8.1		6.8	6.8		4.7	4.7		3.1	2.9
54.0	7.6	8.5	7.2	7.3	7.4		6.6	6.5		4.7	4.6		2.9	2.8
58.0	7.0	7.8	6.6	6.6	6.8	5.4	6.0	6.0		4.6	4.5		2.9	2.7
62.0	6.4	7.1	5.7	5.6	6.0	4.6	5.3	3.5	3.5	4.6	4.4	2.7	2.9	2.7
66.0		6.6	5.0		5.2	3.9		4.6	2.8	4.3	4.3	2.1	2.8	2.6
70.0		6.0	4.3		4.5	3.3		4.0	2.2		3.8	1.6		2.6
74.0			3.7			2.7		3.3	1.7		3.2			2.5
θ(°)	8~59	8~58	8~50	8~58	8~55	8~45	8~56	8~64	8~41	8~64	8~59	8~31	8~63	8~55
標準フック	12.2t													
フック質量	440kg													
標準巻掛本数	1													

PS+ラフィングジブ

カウンタウエイト 98t、アウトリガ張出幅 8.5m
PS+ブーム+2.5m+20.3mLJ

ブーム長さ ブーム起伏角 作業半径 (m)	35.3m			40.4m			45.4m			単位:t	
	83°	75°	68°	83°	75°	68°	83°	75°	68°		
16.0	39.8										
18.0	35.5			31.1							
20.0	31.7			27.6			26.7				
22.0	28.0			22.0			21.5				
24.0		30.1					18.5				
26.0		27.2			21.4						
28.0		21.3			19.0						
30.0			22.8		16.5			16.4			
32.0			20.3								
34.0						15.9					
36.0									14.0		
θ(°)	18~58	18~57	18~47	18~54	18~67	18~48	18~64	18~52	18~49		
標準フック	80t			35t							
フック質量	1550kg			950kg							
標準巻掛本数	4			3							

カウンタウエイト 98t、アウトリガ張出幅 8.5m
PS+ブーム+2.5m+32.3mLJ

ブーム長さ ブーム起伏角 作業半径 (m)	35.3m			40.4m			45.4m			50.5m			単位:t
	83°	75°	68°	83°	75°	68°	83°	75°	68°	83°	75°	68°	
18.0	30.8												
20.0	30.3			20.8									
22.0	29.4			20.3			16.5			12.5			
24.0	26.9			19.9			16.1			12.1			
26.0	22.4			19.0			15.8			11.9			
28.0	20.4	22.8		17.5			15.6			11.7			
30.0	18.6	20.9		16.0	17.7		15.3			11.6			
32.0	16.9	19.3		14.5	16.2		13.9	15.1		11.3			
34.0	15.2	17.8	18.6	13.1	15.0		12.5	14.2		11.0	11.5		
36.0		16.3	17.2		13.8			13.0		11.0	11.2		
38.0		14.9	16.0		12.6	13.7		12.0			10.9		
40.0		13.4	14.9		11.5	12.7		11.0	11.9		10.7		
42.0			13.9		10.3	11.7		9.9	11.0		10.2		
44.0			12.9			10.8			10.2		9.1	9.1	
46.0						9.9			9.4			8.4	
48.0									8.6			7.8	
50.0												7.3	
θ(°)	8~64	8~61	8~52	8~60	8~69	8~53	8~58	8~57	8~53	8~65	8~62	8~54	
θ(°)性能表示範囲	8~61	8~58	8~49	8~58	8~63	8~49	8~56	8~54	8~50	8~62	8~58	8~51	
標準フック				35t									
フック質量				950kg									
標準巻掛本数	3			2									

カウンタウエイト 98t、アウトリガ張出幅 8.5m
PS+ブーム+2.5m+34.0mLJ

ブーム長さ ブーム起伏角 作業半径 (m)	35.3m			40.4m			45.4m			50.5m			55.6m			単位:t
	83°	75°	68°	83°	75°	68°	83°	75°	68°	83°	75°	68°	83°	75°	68°	
18.0	27.8															
20.0	24.4			19.8												
22.0	22.8			19.3			15.6									
24.0	21.2			18.9			15.2			11.5				7.9		
26.0	19.4			18.4			15.0			11.4				7.7		
28.0	17.7	21.2		17.6			14.7			11.4				7.7		
30.0	16.1	19.5		16.1	17.5		14.4			11.1				7.7		
32.0	14.6	18.0		14.6	16.3		13.8	14.4		11.0				7.7		
34.0	12.9	16.6		13.3	15.0		12.7	14.1		10.7	11.1			7.7		
36.0		15.3	16.8	12.0	13.8		11.4	13.2		10.6	10.8			7.5	7.2	
38.0		14.0	15.6		12.7	13.6		12.0		10.5				7.2	7.2	
40.0		12.8	14.5		11.7	12.6		11.0		10.5				7.0		
42.0		11.4	13.5		10.6	11.7		10.1	10.5	10.1				7.0		
44.0		12.7			10.8	9.1		9.7		9.3	8.8			7.0		
46.0			11.8			10.0			9.0	8.3	8.1			6.6	6.9	
48.0						9.1			8.4	7.5				6.7		
50.0									7.8		7.0			6.3		
54.0														5.3		
θ(°)	8~56	8~64	8~54	8~62	8~55	8~59	8~59	8~56	8~57	8~64	8~45	8~63	8~55	8~58		
標準フック				35t						12.2t						
フック質量				950kg						440kg						
標準巻掛本数	3			2						1						

カウンタウエイト 98t、アウトリガ張出幅 8.5m
PS+ブーム+2.5m+40.0mLJ

ブーム長さ ブーム起伏角 作業半径 (m)	35.3m			40.4m			45.4m			50.5m			55.6m			単位:t
	83°	75°	68°	83°	75°	68°	83°	75°	68°	83°	75°	68°	83°	75°	68°	
20.0	20.8															
22.0	20.4			17.2												
24.0	20.0			16.8			13.4									
26.0	19.6			16.5			13.2			10.3				8.2		
28.0	18.7			16.2			13.1			10.3				8.0		
30.0	17.7	19.1		15.9			13.0			10.2				7.8		
32.0	16.7	18.8		15.6			12.8			10.0				7.7		
34.0	15.7	18.1		15.0	15.4		12.7			9.8				7.5		
36.0	14.8	17.0		14.1	15.0		12.4	12.6		9.7				7.3		
38.0	14.0	15.8		13.0	14.2		11.3	12.1		9.6	9.7			7.2	7.3	
40.0	12.9	14.7	13.9	11.9	13.2		10.3	11.4		9.4	9.5			7.0	7.1	
42.0		13.6	13.0	10.8	12.3	11.2	9.3	10.5		9.2	9.4			6.9	6.9	
44.0		12.6	12.1		11.5	10.3		9.7	9.0		9.2			6.7	6.8	
46.0		11.5	11.2		10.6	9.6		9.0	8.3		8.8			6.6		
48.0		10.4	10.5		9.8	8.9		8.3	7.7		8.3	6.8		6.5		
50.0			9.8			8.3		7.5	7.1		7.6	6.3		6.3	5.9	
54.0								6.1				5.4		5.0		
58.0												4.6		4.2		
θ(°)	8~59	8~65	8~45	8~64	8~57	8~39	8~61	8~60	8~46	8~59	8~54	8~58	8~65	8~49	8~47	
標準フック				35t						12.2t						
フック質量				950kg						440kg						
標準巻掛本数				2						1						

カウンタウエイト 98t、アウトリガ張出幅 8.5m
PS+ブーム+2.5m+46.0m(ヘビー)LJ

ブーム長さ ブーム起伏角 作業半径(m)	35.3m			40.4m			45.4m			50.5m			55.6m			
	83°	75°	68°	83°	75°	68°	83°	75°	68°	83°	75°	68°	83°	75°	68°	
22.0	17.1															
24.0	16.8			14.0												
26.0	16.5			13.8			12.0			9.2						
28.0	16.2			13.7			11.8			9.0				6.6		
30.0	16.0			13.5			11.6			8.9				6.5		
32.0	15.7			13.3			11.5			8.7				6.3		
34.0	15.4	15.4		13.2			11.4			8.6				6.2		
36.0	14.8	15.2		13.0	13.1		11.2			8.5				6.1		
38.0	13.7	14.4		12.2	12.9		11.0	11.2		8.3				6.0		
40.0	12.7	13.5		11.3	12.0		10.6	10.9		8.2	8.2			5.9		
42.0	11.8	12.6		11.5	10.5	11.2	9.7	10.2		8.1	8.1			5.8	5.7	
44.0	10.9	11.8	10.6	9.6	10.4		8.9	9.5		7.9	7.9			5.7	5.6	
46.0	9.9	11.0	9.8	8.8	9.7	8.1	8.2	8.9		7.8	7.8			5.6	5.5	
48.0		10.2	9.1		9.0	7.5	7.5	8.3	6.4	7.5	7.7			5.5	5.4	
50.0			9.5	8.4		8.4	6.9	7.7	5.9	7.5	5.5	5.5		5.3	5.3	
54.0				7.3		7.1	5.9		6.6	4.9	6.5	4.6		5.0	3.5	
58.0							5.0			4.1		5.4	3.9		4.8	
62.0													3.1		2.2	
66.0															1.6	
θ(°)	8~60	8~49	8~41	8~58	8~58	8~47	8~63	8~53	8~41	8~61	8~66	8~48	8~66	8~58	8~59	
標準フック	35t						12.2t									
フック質量	950kg						440kg									
標準巻掛本数	2						1									

カウンタウエイト 98t、アウトリガ張出幅 8.5m
PS+ブーム+2.5m+52.0m(ヘビー)LJ

ブーム長さ ブーム起伏角 作業半径(m)	35.3m			40.4m			45.4m			50.5m			55.6m			
	83°	75°	68°	83°	75°	68°	83°	75°	68°	83°	75°	68°	83°	75°	68°	
24.0	15.5															
26.0	15.3															
28.0	15.1			12.9			10.5			7.8						
30.0	14.9			12.7			10.3			7.7				5.4		
32.0	14.8			12.6			10.2			7.5				5.4		
34.0	14.6			12.4			10.1			7.4				5.3		
36.0	14.5	14.5		12.3			10.0			7.3				5.2		
38.0	14.4	13.9		12.0			9.9			7.2				5.1		
40.0	14.1	13.3		11.7	11.4		9.7	9.8		7.1				5.0		
42.0	13.2	12.8		10.9	10.9		9.6	9.7		7.0	7.0			4.9		
44.0	12.3	12.2		10.1	10.4		9.4	9.4		7.0	6.9			4.9	4.8	
46.0	11.5	11.7	8.9	9.4	9.9		8.7	9.0		6.9	6.8			4.8	4.7	
48.0	10.6	10.8	8.2	8.7	9.3		8.1	8.4		6.8	6.7			4.7	4.6	
50.0	9.8	10.1	7.6	8.1	8.6	5.8	7.4	7.9		6.7	6.6			4.7	4.5	
54.0		8.8	6.5		7.4	4.9	6.2	6.8	4.6	6.3	6.4	3.5		4.5	4.4	
58.0		7.7	5.5		6.4	4.0		5.9	3.8		5.6	2.8		4.2	2.3	
62.0			4.7			3.3		5.0	3.1		4.8	2.2		4.0	1.7	
66.0									2.5			1.6				
θ(°)	8~56	8~56	8~48	8~55	8~52	8~43	8~64	8~62	8~49	8~62	8~57	8~43	8~60	8~52	8~30	
標準フック	35t						12.2t									
フック質量	950kg						440kg									
標準巻掛本数	2						1									

カウンタウエイト 98t、アウトリガ張出幅 8.5m
PS+ブーム+2.5m+58.0m(ヘビー)LJ

ブーム長さ ブーム起伏角 作業半径(m)	35.3m			40.4m			45.4m			50.5m			55.6m	
	83°	75°	68°	83°	75°	68°	83°	75°	68°	83°	75°	83°	75°	
26.0	14.1													
28.0	13.9			11.2										
30.0	13.8			11.1			8.7							
32.0	13.6			11.0			8.6			6.1		4.1		
34.0	13.4			10.8			8.5			6.0		4.0		
36.0	13.3			10.7			8.3			6.0		3.9		
38.0	13.2	13.2		10.6			8.3			5.9		3.8		
40.0	12.8	12.7		10.5			8.2			5.8		3.8		
42.0	12.1	12.1		10.2	10.3		8.1			5.7		3.7		
44.0	11.4	11.5		10.0	10.1		8.0	8.0		5.7		3.7		
46.0	10.7	11.0		9.3	9.5		7.9	7.9		5.6	5.5	3.6		
48.0	10.0	10.1	7.4	8.7	8.9		7.8	7.7		5.5	5.5	3.6	3.5	
50.0	9.3	9.4	6.8	8.1	8.3		7.4	7.2		5.5	5.4	3.6	3.4	
54.0	8.0	8.1	5.7	7.0	7.1	4.4	6.3	6.0		5.4	5.1	3.4	3.3	
58.0	6.8	7.0	4.7	5.9	6.0	3.6	5.4	5.1	2.4	5.2	4.2	3.4	3.2	
62.0		6.0	3.9		5.1	2.8		4.2	1.7		3.5		2.9	
66.0			3.2		4.3	2.2					2.8		2.2	
70.0						1.6							1.6	
θ(°)	8~63	8~52	8~44	8~61	8~60	8~50	8~59	8~56	8~29	8~58	8~52	8~57	8~60	
標準フック	35t						12.2t							
フック質量	950kg						440kg							
標準巻掛本数	2						1							

PS+ラフィングジブ

カウンタウエイト 98t、アウトリガ張出幅 8.5m

PS+ブーム+2.5m+46.0m(ライト)LJ

単位:t

ブーム長さ	35.3m			40.4m			45.4m			50.5m			55.6m		
ブーム起伏角 作業半径(m)	83°	75°	68°	83°	75°	68°	83°	75°	68°	83°	75°	68°	83°	75°	68°
22.0	17.7														
24.0	17.1														
26.0	16.4			14.2			12.6			9.3					
28.0	15.5			13.9			12.5			9.1				6.8	
30.0	14.5			13.7			12.3			9.0				6.7	
32.0	13.7			13.2			12.1			8.8				6.5	
34.0	12.8	14.9		12.6			11.9			8.7				6.4	
36.0	12.0	14.1		12.0	13.3		11.5			8.6				6.3	
38.0	11.3	13.2		11.3	13.0		11.1	11.9		8.4				6.2	
40.0	10.7	12.4		10.7	12.3		10.6	11.7		8.3	8.4			6.1	
42.0	10.1	11.7	12.1	10.1	11.6		10.2	11.4		8.2	8.2			6.0	5.9
44.0	9.5	11.0	11.2	9.6	10.8		9.7	10.8		8.1	8.1			5.9	5.8
46.0	9.0	10.4	10.4	9.1	10.1	8.6	9.1	10.1		7.9	8.0			5.7	5.7
48.0		9.8	9.7		9.4	8.0	8.4	9.4	7.2	7.7	7.8			5.6	5.6
50.0		9.3	9.1		8.7	7.4		8.8	6.6	7.7	7.7	6.2		5.5	5.5
54.0			7.9		7.4	6.4		7.6	5.7	6.8	6.8	5.3		5.3	4.2
58.0						5.5			4.8	5.6	5.6	4.5		5.0	3.5
62.0												3.8			2.9
66.0															2.3
θ(°)	8~60	8~49	8~41	8~58	8~58	8~47	8~63	8~53	8~41	8~61	8~66	8~48	8~66	8~58	8~59
標準フック	35t						12.2t						12.2t		
フック質量	950kg						440kg						440kg		
標準巻掛本数	2						1						1		

カウンタウエイト 98t、アウトリガ張出幅 8.5m

PS+ブーム+2.5m+52.0m(ライト)LJ

単位:t

ブーム長さ	35.3m			40.4m			45.4m			50.5m			55.6m		
ブーム起伏角 作業半径(m)	83°	75°	68°	83°	75°	68°	83°	75°	68°	83°	75°	68°	83°	75°	68°
26.0	14.0									7.8					
28.0	13.3			12.0			10.2			7.8					
30.0	12.7			11.6			10.1			7.6				5.6	
32.0	12.0			11.1			9.8			7.5				5.5	
34.0	11.4			10.5			9.6			7.4				5.4	
36.0	10.7			10.0			9.2			7.3				5.3	
38.0	10.1	11.7		9.5			8.9			7.2				5.2	
40.0	9.5	11.0		9.0	10.4		8.5	9.4		7.1				5.1	
42.0	9.0	10.4		8.5	9.9		8.2	9.2		7.1	7.0			5.1	
44.0	8.5	9.8		8.0	9.4		7.8	8.8		6.9	7.0			5.0	4.9
46.0	8.0	9.3	9.3	7.6	8.9		7.4	8.5		6.7	6.9			4.9	4.8
48.0	7.6	8.7	8.6	7.2	8.4		7.1	8.2		6.5	6.8			4.9	4.8
50.0	7.2	8.3	8.0	6.8	8.0	6.4	6.8	7.5		6.3	6.7			4.8	4.7
54.0		7.4	6.9		7.2	5.5	6.1	7.1	5.3	5.8	6.5	4.2		4.6	4.5
58.0		6.7	6.0		6.4	4.6		6.2	4.5	5.8	6.0	3.5		4.4	2.9
62.0			5.1			3.9		5.2	3.8		5.2	2.9		4.2	2.3
66.0								3.2			2.3				1.8
θ(°)	8~56	8~56	8~48	8~55	8~52	8~43	8~64	8~62	8~49	8~62	8~57	8~43	8~60	8~52	8~39
標準フック	35t						12.2t						12.2t		
フック質量	950kg						440kg						440kg		
標準巻掛本数	2						1						1		

カウンタウエイト 98t、アウトリガ張出幅 8.5m

PS+ブーム+2.5m+58.0m(ライト)LJ

単位:t

ブーム長さ	35.3m			40.4m			45.4m			50.5m			55.6m	
ブーム起伏角 作業半径(m)	83°	75°	68°	83°	75°	68°	83°	75°	68°	83°	75°	68°	83°	75°
26.0	14.1													
28.0	13.9			11.3										
30.0	13.8			11.2			8.8							
32.0	13.6			11.1			8.7			6.4			4.4	
34.0	13.4			11.0			8.6			6.3			4.3	
36.0	13.1			10.8			8.5			6.2			4.2	
38.0	12.7	13.3		10.7			8.5			6.1			4.1	
40.0	12.2	13.0		10.6			8.4			6.1			4.1	
42.0	11.8	12.5		10.5	10.5		8.3			6.0			4.0	
44.0	11.4	12.0		10.3	10.4		8.2	8.2		5.9			4.0	
46.0	10.9	11.4		9.7	10.0		8.1	8.1		5.8	5.8		3.9	
48.0	10.3	10.7		9.0	9.3		8.1	8.0		5.8	5.7		3.9	3.7
50.0	9.6	10.0	7.4	8.4	8.7		7.7	7.8		5.7	5.7		3.8	3.7
54.0	8.4	8.7	6.3	7.3	7.7	5.1	6.7	6.7		5.6	5.5		3.7	3.6
58.0	7.1	7.6	5.4	6.2	6.7	4.2	5.7	5.7	3.1	5.5	4.9	2.0	3.7	3.5
62.0		6.6	4.6		5.7	3.5		4.9	2.4		4.1	1.5		3.4
66.0			3.8		4.9	2.8		4.2	1.8		3.4			2.9
70.0						2.3								2.4
θ(°)	8~63	8~52	8~44	8~61	8~60	8~50	8~59	8~56	8~36	8~58	8~52	8~26	8~57	8~60
標準フック	35t						12.2t						12.2t	
フック質量	950kg						440kg						440kg	
標準巻掛本数	2						1						1	

カウンタウエイト 98t、アウトリガ張出幅 8.5m

PS+ブーム+2.5m+64.0m(ライト)LJ

単位:t

ブーム長さ	35.3m			40.4m			45.4m			50.5m		55.6m		
ブーム起伏角 作業半径(m)	83°	75°	68°	83°	75°	68°	83°	75°	68°	83°	75°	83°	75°	
28.0	12.2													
30.0	12.1			9.5										
32.0	11.7			9.5			7.4							
34.0	11.4			9.4			7.3			5.1		3.4		
36.0	11.0			9.3			7.3			5.0		3.3		
38.0	10.6			9.2			7.2			5.0		3.3		
40.0	10.2			9.0			7.1			5.0		3.2		
42.0	9.8	10.8		8.8			7.1			5.0		3.2		
44.0	9.4	10.4		8.6	9.0		7.0			4.9		3.2		
46.0	9.0	10.0		8.3	8.8		6.9	6.9		4.8		3.1		
48.0	8.6	9.6		8.1	8.4		6.9	6.8		4.8	4.7	3.1		
50.0	8.3	9.1		7.8	7.9		6.8	6.7		4.7	4.7	3.1	2.9	
54.0	7.6	7.9	5.4	7.3	6.7		6.6	5.6		4.7	4.6	2.9	2.8	
58.0	7.0	6.8	4.5	6.6	5.7	3.2	6.0	4.7	4.6	4.1	2.9	2.7	2.7	
62.0	6.4	5.8	3.8	5.6	4.8	2.5	5.1	3.9	4.6	3.3	2.9	2.7	2.7	
66.0		5.0	3.1		4.1	1.9		3.2	4.3	2.7	2.8	2.2	2.2	
70.0		4.3	2.5		3.4			2.5		2.1		1.7		
74.0			1.9					2.1		1.6				
θ(°)	8~59	8~58	8~50	8~58	8~55	8~31	8~56	8~64	8~59	8~63	8~46			
標準フック	35t						12.2t						12.2t	
フック質量	950kg						440kg						440kg	
標準巻掛本数	2						1						1	

カウンタウエイト 98t、アウトリガ張出幅 8.0m

PS+ブーム+2.5m+20.3mLJ

単位:t

ブーム長さ ブーム起伏角 作業半径(m)	35.3m			40.4m			45.4m		
	83°	75°	68°	83°	75°	68°	83°	75°	68°
16.0	39.8								
18.0	35.5			31.1					
20.0	31.7			27.6			26.7		
22.0	28.0			22.0			21.5		
24.0		30.1					18.5		
26.0		27.2			21.4				
28.0		21.3			19.0				
30.0			22.8		16.5			16.4	
32.0			20.3						
34.0					15.9				
36.0									14.0
θ(°)	18~58	18~57	18~47	18~54	18~67	18~48	18~64	18~52	18~49
標準フック	80t			35t					
フック質量	1550kg			950kg					
標準巻掛本数	4			3					

カウンタウエイト 98t、アウトリガ張出幅 8.0m

PS+ブーム+2.5m+32.3mLJ

単位:t

ブーム長さ ブーム起伏角 作業半径(m)	35.3m			40.4m			45.4m			50.5m		
	83°	75°	68°	83°	75°	68°	83°	75°	68°	83°	75°	68°
18.0	30.8											
20.0	30.3			20.8								
22.0	29.4			20.3			16.5			12.5		
24.0	26.9			19.9			16.1			12.1		
26.0	22.4			19.0			15.8			11.9		
28.0	20.4	22.8		17.5			15.6			11.7		
30.0	18.6	20.9		16.0	17.7		15.3			11.6		
32.0	16.9	19.3		14.5	16.2		13.9	15.1		11.3		
34.0	15.2	17.8	17.9	13.1	15.0		12.5	14.2		11.0	11.5	
36.0		16.3	16.6		13.8		13.0			11.0	11.2	
38.0		14.9	15.4		12.6	13.7		12.0			10.9	
40.0		13.4	14.3		11.5	12.7		11.0	11.2		10.7	
42.0			13.3		10.3	11.7		9.9	10.4		10.2	
44.0			12.5			10.8			9.6		9.1	8.5
46.0						9.9			8.9			7.8
48.0									8.3			7.2
50.0												6.7
θ(°)	8~64	8~61	8~52	8~60	8~69	8~53	8~58	8~57	8~53	8~65	8~62	8~54
標準フック				35t								
フック質量				950kg								
標準巻掛本数	3						2					

カウンタウエイト 98t、アウトリガ張出幅 8.0m

PS+ブーム+2.5m+34.0mLJ

単位:t

ブーム長さ ブーム起伏角 作業半径(m)	35.3m			40.4m			45.4m			50.5m			55.6m		
	83°	75°	68°	83°	75°	68°	83°	75°	68°	83°	75°	68°	83°	75°	68°
18.0	27.8														
20.0	24.4			19.8											
22.0	22.8			19.3			15.6								
24.0	21.2			18.9			15.2			11.5				7.9	
26.0	19.4			18.4			15.0			11.4				7.7	
28.0	17.7	21.2		17.6			14.7			11.4				7.7	
30.0	16.1	19.5		16.1	17.5		14.4			11.1				7.7	
32.0	14.6	18.0		14.6	16.3		13.8	14.4		11.0				7.7	
34.0	12.9	16.6		13.3	15.0		12.7	14.1		10.7	11.1			7.7	
36.0		15.3	16.1	12.0	13.8		11.4	13.2		10.6	10.8			7.5	7.2
38.0		14.0	15.0		12.7	13.6		12.0			10.5			7.2	7.2
40.0		12.8	13.9		11.7	12.5		11.0			10.5			7.0	
42.0		11.4	13.0		10.6	11.6		10.1	9.9		10.1			7.0	
44.0			12.1			10.8		9.1	9.1		9.3	8.1		7.0	
46.0			11.3			10.0			8.4		8.3	7.5		6.6	6.7
48.0						9.1			7.8			6.9			6.2
50.0									7.2			6.4			5.7
54.0												6.4			4.8
θ(°)	8~56	8~64	8~54	8~62	8~55	8~55	8~59	8~59	8~56	8~57	8~64	8~45	8~63	8~55	8~58
標準フック				35t									12.2t		
フック質量				950kg									440kg		
標準巻掛本数	3						2						1		

カウンタウエイト 98t、アウトリガ張出幅 8.0m

PS+ブーム+2.5m+40.0mLJ

単位:t

ブーム長さ ブーム起伏角 作業半径(m)	35.3m			40.4m			45.4m			50.5m			55.6m		
	83°	75°	68°	83°	75°	68°	83°	75°	68°	83°	75°	68°	83°	75°	68°
20.0	20.8														
22.0	20.4			17.2											
24.0	20.0			16.8			13.4								
26.0	19.6			16.5			13.2			10.3				8.2	
28.0	18.7			16.2			13.1			10.3				8.0	
30.0	17.7	19.1		15.9			13.0			10.2				7.8	
32.0	16.7	18.8		15.6			12.8			10.0				7.7	
34.0	15.7	18.1		15.0	15.4		12.7			9.8				7.5	
36.0	14.8	17.0		14.1	15.0		12.4	12.6		9.7				7.3	
38.0	14.0	15.8		13.0	14.2		11.3	12.1		9.6	9.7			7.2	7.3
40.0	12.9	14.7	13.3	11.9	13.2		10.3	11.4		9.4	9.5			7.0	7.1
42.0		13.6	12.3	10.8	12.3	10.5	9.3	10.5		9.2	9.4			6.9	6.9
44.0		12.6	11.5		11.5	9.7		9.7	8.4		9.2			6.7	6.8
46.0		11.5	10.7		10.6	9.0		9.0	7.1		8.8			6.6	6.6
48.0		10.4	9.9		9.8	8.4		8.3	7.1		8.3	6.2		6.5	6.5
50.0			9.2			7.8		7.5	6.6		7.6	5.7		6.3	5.3
54.0									5.6			4.9			4.5
58.0												4.1			3.7
θ(°)	8~59	8~65	8~45	8~64	8~57	8~39	8~61	8~60	8~46	8~59	8~54	8~58	8~65	8~49	8~47
標準フック				35t									12.2t		
フック質量				950kg									440kg		
標準巻掛本数				2									1		

PS+ラフィングジブ

カウンタウエイト 98t、アウトリガ張出幅 8.0m
PS+ブーム+2.5m+46.0m(ヘビー)LJ

ブーム長さ ブーム起伏角 作業半径(m)	35.3m			40.4m			45.4m			50.5m			55.6m			単位:t	
	83°	75°	68°	83°	75°	68°	83°	75°	68°	83°	75°	68°	83°	75°	68°		
22.0	17.1																
24.0	16.8			14.0													
26.0	16.5			13.8			12.0			9.2							
28.0	16.2			13.7			11.8			9.0				6.6			
30.0	16.0			13.5			11.6			8.9				6.5			
32.0	15.7			13.3			11.5			8.7				6.3			
34.0	15.4	15.4		13.2			11.4			8.6				6.2			
36.0	14.8	15.2		13.0	13.1		11.2			8.5				6.1			
38.0	13.7	14.4		12.2	12.9		11.0	11.2		8.3				6.0			
40.0	12.7	13.5		11.3	12.0		10.6	10.9		8.2	8.2			5.9			
42.0	11.8	12.6	10.8	10.5	11.2		9.7	10.2		8.1	8.1			5.8	5.7		
44.0	10.9	11.8	10.0	9.6	10.4		8.9	9.5		7.9	7.9			5.7	5.6		
46.0	9.9	11.0	9.2	8.8	9.7	7.5	8.2	8.9		7.8	7.8			5.6	5.5		
48.0		10.2	8.5		9.0	6.9	7.5	8.3	5.8	7.5	7.7			5.5	5.4		
50.0		9.5	7.9		8.4	6.4		7.7	5.3		7.5	4.9		5.3	5.3		
54.0			6.8		7.1	5.4		6.6	4.4		6.5	4.1		5.0	3.0		
58.0						4.5			3.6		5.4	3.3		4.8	2.3		
62.0												2.6			1.7		
θ(°)	8~60	8~49	8~41	8~58	8~58	8~47	8~63	8~53	8~41	8~61	8~66	8~48	8~66	8~58	8~42		
標準フック	35t						12.2t										
フック質量	950kg						440kg										
標準巻掛本数	2						1										

カウンタウエイト 98t、アウトリガ張出幅 8.0m
PS+ブーム+2.5m+52.0m(ヘビー)LJ

ブーム長さ ブーム起伏角 作業半径(m)	35.3m			40.4m			45.4m			50.5m			55.6m			単位:t	
	83°	75°	68°	83°	75°	68°	83°	75°	68°	83°	75°	68°	83°	75°	68°		
24.0	15.5																
26.0	15.3																
28.0	15.1			12.9			10.5			7.8							
30.0	14.9			12.7			10.3			7.7				5.4			
32.0	14.8			12.6			10.2			7.5				5.4			
34.0	14.6			12.4			10.1			7.4				5.3			
36.0	14.5	14.5		12.3			10.0			7.3				5.2			
38.0	14.4	13.9		12.0			9.9			7.2				5.1			
40.0	14.1	13.3		11.7	11.4		9.7	9.8		7.1				5.0			
42.0	13.2	12.8		10.9	10.9		9.6	9.7		7.0	7.0			4.9			
44.0	12.3	12.0		10.1	10.3		9.4	9.4		7.0	6.9			4.9	4.8		
46.0	11.5	11.1	8.3	9.4	9.5		8.7	9.0		6.9	6.8			4.8	4.7		
48.0	10.6	10.3	7.6	8.7	8.8		8.1	8.4		6.8	6.7			4.7	4.6		
50.0	9.8	9.6	7.0	8.1	8.1	5.3	7.4	7.9		6.7	6.6			4.7	4.5		
54.0		8.3	6.0		6.9	4.4	6.2	6.8	4.1	6.3	6.1	3.0		4.5	4.4		
58.0		7.2	5.0		5.9	3.6		5.9	3.3		5.2	2.3		4.2	1.8		
62.0			4.2			2.9		5.0	2.7		4.3	1.7		4.0			
66.0									2.1								
θ(°)	8~56	8~56	8~48	8~55	8~52	8~43	8~64	8~62	8~49	8~62	8~57	8~34	8~60	8~52	8~24		
標準フック	35t						12.2t										
フック質量	950kg						440kg										
標準巻掛本数	2						1										

カウンタウエイト 98t、アウトリガ張出幅 8.0m
PS+ブーム+2.5m+58.0m(ヘビー)LJ

ブーム長さ ブーム起伏角 作業半径(m)	35.3m			40.4m			45.4m			50.5m			55.6m			単位:t	
	83°	75°	68°	83°	75°	68°	83°	75°	68°	83°	75°	68°	83°	75°	68°		
28.0	14.1																
30.0	13.8			11.2													
32.0	13.6			11.1			8.7										
34.0	13.4			11.0			8.6			6.1			4.1				
36.0	13.3			10.8			8.5			6.0			4.0				
38.0	13.2	13.2		10.7			8.3			6.0			3.9				
40.0	12.8	12.7		10.6			8.3			5.9			3.8				
42.0	12.1	12.1		10.5			8.2			5.8			3.8				
44.0	11.4	11.3		10.2	10.3		8.1			5.7			3.7				
46.0	10.7	10.4		10.0	10.0		8.0	8.0		5.7			3.7				
48.0	10.0	9.6	6.9	9.3	9.2		7.9	7.9		5.6	5.5		3.6				
50.0	9.3	8.9	6.3	8.7	8.4		7.8	7.2		5.5	5.5		3.6	3.5			
54.0	8.0	7.6	5.2	8.1	7.8		7.4	6.6		5.5	5.4		3.6	3.4			
58.0	6.8	6.5	4.3	5.9	5.6	3.1	5.4	4.6	1.9	5.2	3.8	3.4	3.1				
62.0		5.6	3.5		4.7	2.4		3.8			3.0		2.4				
66.0			2.8		3.9	1.8		3.1			2.4		1.8				
θ(°)	8~63	8~52	8~44	8~61	8~60	8~40	8~59	8~56	8~23	8~58	8~52	8~57	8~49				
標準フック	35t						12.2t										
フック質量	950kg						440kg										
標準巻掛本数	2						1										

カウンタウエイト 98t、アウトリガ張出幅 8.0m

PS+ブーム+2.5m+46.0m(ライト)LJ

単位:t

ブーム長さ ブーム起伏角 作業半径(m)	35.3m			40.4m			45.4m			50.5m			55.6m		
	83°	75°	68°	83°	75°	68°	83°	75°	68°	83°	75°	68°	83°	75°	68°
22.0	17.7														
24.0	17.1														
26.0	16.4			14.2			12.6			9.3					
28.0	15.5			13.9			12.5			9.1			6.8		
30.0	14.5			13.7			12.3			9.0			6.7		
32.0	13.7			13.2			12.1			8.8			6.5		
34.0	12.8	14.9		12.6			11.9			8.7			6.4		
36.0	12.0	14.1		12.0	13.3		11.5			8.6			6.3		
38.0	11.3	13.2		11.3	13.0		11.1	11.9		8.4			6.2		
40.0	10.7	12.4		10.7	12.3		10.6	11.7		8.3	8.4		6.1	5.9	
42.0	10.1	11.7	11.5	10.1	11.6		10.2	11.4		8.2	8.2		6.0	5.8	
44.0	9.5	11.0	10.6	9.6	10.8		9.7	10.6		8.1	8.1		5.9	5.8	
46.0	9.0	10.4	9.9	9.1	10.1	8.0	9.1	10.1		7.9	8.0		5.7	5.7	
48.0		9.8	9.2		9.4	7.4	8.4	9.4	6.6	7.7	7.8		5.6	5.6	
50.0		9.3	8.5		8.7	6.8		8.8	6.1	7.7	5.7		5.5	5.5	
54.0			7.4		7.4	5.9		7.6	5.1	6.8	4.8		5.3	3.7	
58.0					5.0				4.3	5.6	4.0		5.0	3.0	
62.0											3.4			2.4	
66.0														1.9	
θ(°)	8~60	8~49	8~41	8~58	8~58	8~47	8~63	8~53	8~41	8~61	8~66	8~48	8~66	8~58	8~59
標準フック	35t												12.2t		
フック質量	950kg												440kg		
標準巻掛本数	2												1		

カウンタウエイト 98t、アウトリガ張出幅 8.0m

PS+ブーム+2.5m+52.0m(ライト)LJ

単位:t

ブーム長さ ブーム起伏角 作業半径(m)	35.3m			40.4m			45.4m			50.5m			55.6m		
	83°	75°	68°	83°	75°	68°	83°	75°	68°	83°	75°	68°	83°	75°	68°
26.0	14.0									7.8					
28.0	13.3			12.0			10.2			7.6			5.6		
30.0	12.7			11.6			10.1			7.5			5.5		
32.0	12.0			11.1			9.8			7.4			5.4		
34.0	11.4			10.5			9.6			7.4			5.3		
36.0	10.7			10.0			9.2			7.3			5.2		
38.0	10.1	11.7		9.5			8.9			7.2			5.1		
40.0	9.5	11.0		9.0	10.4		8.5	9.4		7.1			5.0	4.9	
42.0	9.0	10.4		8.5	9.9		8.2	9.2		7.1	7.0		4.9	4.8	
44.0	8.5	9.8		8.0	9.4		7.8	8.8		6.9	7.0		4.8	4.7	
46.0	8.0	9.3	8.7	7.6	8.9		7.4	8.5		6.7	6.9		4.7	4.6	
48.0	7.6	8.7	8.0	7.2	8.4		7.1	8.2		6.5	6.8		4.6	4.5	
50.0	7.2	8.3	7.4	6.8	8.0	5.9	6.8	7.8		6.3	6.7		4.5	4.4	
54.0		7.4	6.4		7.2	4.9	6.1	7.1	4.8	5.8	6.5	3.7	4.4	2.4	
58.0		6.7	5.5		6.4	4.1		6.2	4.0	5.8	3.0		4.2	1.9	
62.0			4.7			3.5		5.2	3.4	5.0	2.4				
66.0									2.7		1.9				
θ(°)	8~56	8~56	8~48	8~55	8~52	8~43	8~64	8~62	8~49	8~62	8~57	8~43	8~60	8~52	8~30
標準フック	35t												12.2t		
フック質量	950kg												440kg		
標準巻掛本数	2												1		

カウンタウエイト 98t、アウトリガ張出幅 8.0m

PS+ブーム+2.5m+58.0m(ライト)LJ

単位:t

ブーム長さ ブーム起伏角 作業半径(m)	35.3m			40.4m			45.4m			50.5m			55.6m	
	83°	75°	68°	83°	75°	68°	83°	75°	68°	83°	75°	68°	83°	75°
28.0	14.1													
28.0	13.9			11.3										
30.0	13.8			11.2			8.8							
32.0	13.6			11.1			8.7			6.4			4.4	
34.0	13.4			11.0			8.6			6.3			4.3	
36.0	13.1			10.8			8.5			6.2			4.2	
38.0	12.7	13.3		10.7			8.5			6.1			4.1	
40.0	12.2	13.0		10.6			8.4			6.1			4.1	
42.0	11.8	12.5		10.5	10.5		8.3			6.0			4.0	
44.0	11.4	11.9		10.3	10.4		8.2	8.2		5.9			4.0	
46.0	10.9	11.0		9.7	9.8		8.1	8.1		5.8	5.8		3.9	
48.0	10.3	10.2		9.0	9.1		8.1	7.9		5.8	5.7		3.9	3.7
50.0	9.6	9.5	6.9	8.4	8.4		7.7	7.3		5.7	5.7		3.8	3.7
54.0	8.4	8.2	5.8	7.3	7.2	4.6	6.7	6.2		5.6	5.3		3.7	3.6
58.0	7.1	7.1	4.9	6.2	6.2	3.8	5.7	5.3	2.6	5.5	4.4	1.5	3.7	3.5
62.0		6.2	4.1		5.3	3.0		4.5	2.0		3.7			3.2
66.0			3.4		4.5	2.4					3.0			2.5
70.0						1.9								2.0
θ(°)	8~63	8~52	8~44	8~61	8~60	8~50	8~59	8~56	8~29	8~58	8~52	8~20	8~57	8~60
標準フック	35t												12.2t	
フック質量	950kg												440kg	
標準巻掛本数	2												1	

カウンタウエイト 98t、アウトリガ張出幅 8.0m

PS+ブーム+2.5m+64.0m(ライト)LJ

単位:t

ブーム長さ ブーム起伏角 作業半径(m)	35.3m			40.4m			45.4m			50.5m		55.6m		
	83°	75°	68°	83°	75°	68°	83°	75°	68°	83°	75°	83°	75°	
28.0	12.2													
30.0	12.1			9.5										
32.0	11.7			9.5			7.4							
34.0	11.4			9.4			7.3			5.1		3.4		
36.0	11.0			9.3			7.3			5.0		3.3		
38.0	10.6			9.2			7.2			5.0		3.3		
40.0	10.2			9.0			7.1			5.0		3.2		
42.0	9.8	10.8		8.8			7.1			5.0		3.2		
44.0	9.4	10.4		8.6	9.0		7.0			4.9		3.2		
46.0	9.0	10.0		8.3	8.7		6.9	6.9		4.8		3.1		
48.0	8.6	9.3		8.1	8.0		6.9	6.7		4.8	4.7	3.1		
50.0	8.3	8.6		7.8	7.3		6.8	6.2		4.7	4.7	3.1	2.9	
54.0	7.6	7.4	4.9	7.3	6.2		6.6	5.1		4.7	4.4	2.9	2.8	
58.0	7.0	6.3	4.1	6.6	5.2	2.8	6.0	4.2		4.6	3.6	2.9	2.7	
62.0	6.4	5.4	3.3	5.6	4.4	2.1	5.1	3.5		4.6	2.9	2.9	2.4	
66.0		4.6	2.7		3.7	1.5		2.8		4.3	2.3	2.8	1.8	
70.0		3.9	2.1		3.0			2.2			1.7			
74.0			1.6					1.7						
θ(°)	8~59	8~58	8~50	8~58	8~55	8~31	8~56	8~64	8~24	8~49	8~63	8~39		
標準フック	12.2t													
フック質量	440kg													
標準巻掛本数	1													

PS+ラフィングジブ

カウンタウエイト 98t、アウトリガ張出幅 6.8m

PS+ブーム+2.5m+20.3mLJ

ブーム長さ ブーム起伏角 作業半径 (m)	35.3m			40.4m			45.4m		
	83°	75°	68°	83°	75°	68°	83°	75°	68°
16.0	39.8								
18.0	35.5			31.1					
20.0	31.7			27.6			26.7		
22.0	28.0			22.0			21.5		
24.0		30.1					18.5		
26.0		27.2			21.4				
28.0		21.3			19.0				
30.0			20.1		16.5			16.4	
32.0			18.4						
34.0					15.5				
36.0									13.0
θ(°)	18~58	18~57	18~47	18~54	18~67	18~48	18~64	18~52	18~48
標準フック	80t			35t					
フック質量	1550kg			950kg					
標準巻掛本数	4			3					

カウンタウエイト 98t、アウトリガ張出幅 6.8m

PS+ブーム+2.5m+32.3mLJ

ブーム長さ ブーム起伏角 作業半径 (m)	35.3m			40.4m			45.4m			50.5m		
	83°	75°	68°	83°	75°	68°	83°	75°	68°	83°	75°	68°
18.0	30.8											
20.0	30.3			20.8								
22.0	29.4			20.3			16.5			12.5		
24.0	26.9			19.9			16.1			12.1		
26.0	22.4			19.0			15.8			11.9		
28.0	20.4	22.7		17.5			15.6			11.7		
30.0	18.6	20.7		16.0	17.7		15.3			11.6		
32.0	16.9	19.0		14.5	16.2		13.9	15.1		11.3		
34.0	15.2	17.5	14.6	13.1	15.0		12.5	14.2		11.0	11.5	
36.0		16.2	13.5		13.8			13.0		11.0	11.2	
38.0		14.9	12.5		12.6	10.8		12.0			10.9	
40.0		13.4	11.6		11.5	10.0		11.0	8.2		10.7	
42.0			10.7		10.3	9.2		9.9	7.6		10.0	
44.0			9.9			8.5			7.0		9.1	5.8
46.0						7.9			6.4			5.3
48.0									5.9			4.8
50.0												4.4
θ(°)	8~64	8~61	8~52	8~60	8~69	8~53	8~58	8~57	8~53	8~65	8~62	8~54
標準フック	35t											
フック質量	950kg											
標準巻掛本数	3						2					

カウンタウエイト 98t、アウトリガ張出幅 6.8m

PS+ブーム+2.5m+34.0mLJ

ブーム長さ ブーム起伏角 作業半径 (m)	35.3m			40.4m			45.4m			50.5m			55.6m		
	83°	75°	68°	83°	75°	68°	83°	75°	68°	83°	75°	68°	83°	75°	68°
18.0	27.8														
20.0	24.4			19.8											
22.0	22.8			19.3			15.6								
24.0	21.2			18.9			15.2			11.5				7.9	
26.0	19.4			18.4			15.0			11.4				7.7	
28.0	17.7	21.2		17.6			14.7			11.4				7.7	
30.0	16.1	19.5		16.1	17.5		14.4			11.1				7.7	
32.0	14.6	18.0		14.6	16.3		13.8	14.4		11.0				7.7	
34.0	12.9	16.6		13.3	15.0		12.7	14.1		10.7	11.1			7.7	
36.0		15.3	13.1	12.0	13.8		11.4	13.2		10.6	10.8			7.5	7.2
38.0		14.0	12.0		12.7	10.4		12.0			10.5			7.2	7.2
40.0		12.8	11.1		11.7	9.5		11.0			10.5			7.0	7.0
42.0		11.4	10.2		10.6	8.8		10.1	7.0		9.7			7.0	7.0
44.0			9.5			8.1		9.1	6.4	9.0	5.5			7.0	7.0
46.0			8.7			7.4			5.9	8.3	5.0			6.6	4.2
48.0						6.9			5.4	4.5				3.8	3.8
50.0									4.9	4.1				3.4	3.4
54.0										4.1				2.7	2.7
θ(°)	8~56	8~64	8~54	8~62	8~55	8~55	8~59	8~59	8~56	8~57	8~64	8~45	8~63	8~55	8~58
標準フック	35t						12.2t								
フック質量	950kg						440kg								
標準巻掛本数	3						2			1					

カウンタウエイト 98t、アウトリガ張出幅 6.8m

PS+ブーム+2.5m+40.0mLJ

ブーム長さ ブーム起伏角 作業半径 (m)	35.3m			40.4m			45.4m			50.5m			55.6m		
	83°	75°	68°	83°	75°	68°	83°	75°	68°	83°	75°	68°	83°	75°	68°
20.0	20.8														
22.0	20.4			17.2											
24.0	20.0			16.8			13.4								
26.0	19.6			16.5			13.2			10.3				8.2	
28.0	18.7			16.2			13.1			10.3				8.0	
30.0	17.7	19.1		15.9			13.0			10.2				7.8	
32.0	16.7	17.9		15.6			12.8			10.0				7.7	
34.0	15.7	16.5		15.0	15.0		12.7			9.8				7.5	
36.0	14.8	15.2		14.1	13.8		12.4	12.6		9.7				7.3	
38.0	14.0	14.1		13.0	12.8		11.3	11.6		9.6	9.7			7.2	7.3
40.0	12.9	13.1	10.3	11.9	11.8		10.3	10.6		9.4	9.5			7.0	7.1
42.0		12.2	9.5	10.8	10.9	7.7	9.3	9.8		9.2	9.0			6.9	6.9
44.0		11.4	8.7		10.1	7.0		9.1	5.7	8.3				6.7	6.8
46.0		10.6	8.1		9.4	6.5		8.4	5.2	7.1				6.6	6.6
48.0		9.9	7.5		8.7	5.9		7.8	4.7	6.6				6.3	6.3
50.0			6.9			5.4		7.2	4.3	6.6				6.3	3.1
54.0									3.5					2.8	2.4
58.0														2.1	1.8
θ(°)	8~59	8~65	8~45	8~64	8~57	8~39	8~61	8~60	8~46	8~59	8~54	8~58	8~65	8~49	8~47
標準フック	35t						12.2t								
フック質量	950kg						440kg								
標準巻掛本数				2						1					

カウンタウエイト 98t、アウトリガ張出幅 6.8m

PS+ブーム+2.5m+46.0m(ヘビー)LJ

単位:t

ブーム長さ	35.3m			40.4m			45.4m			50.5m			55.6m		
ブーム起伏角 作業半径(m)	83°	75°	68°	83°	75°	68°	83°	75°	68°	83°	75°	68°	83°	75°	
22.0	17.1														
24.0	16.8			14.0											
26.0	16.5			13.8			12.0			9.2					
28.0	16.2			13.7			11.8			9.0			6.6		
30.0	16.0			13.5			11.6			8.9			6.5		
32.0	15.7			13.3			11.5			8.7			6.3		
34.0	15.4	15.2		13.2			11.4			8.6			6.2		
36.0	14.8	14.0		13.0	12.3		11.2			8.5			6.1		
38.0	13.7	12.9		12.2	11.2		11.0	10.1		8.3			6.0		
40.0	12.7	11.9		11.3	10.3		10.6	9.2		8.2	8.2		5.9	5.7	
42.0	11.8	11.0	8.0	10.5	9.4		9.7	8.5		8.1	8.1		5.8	5.6	
44.0	10.9	10.1	7.3	9.6	8.7		8.9	7.7		7.9	7.6		5.6	5.5	
46.0	9.9	9.4	6.7	8.8	8.0	5.0	8.2	7.1		7.8	7.0		5.6	5.5	
48.0		8.7	6.1		7.3	4.5	7.5	6.5	3.4	7.5	6.4		5.5	5.4	
50.0		8.0	5.6		6.8	4.0		6.0	3.0		5.9	2.6	5.3	4.9	
54.0			4.6		5.7	3.2		5.0	2.2		4.9	1.9		4.0	
58.0						2.5			1.6		4.1			3.3	
θ(°)	8~60	8~49	8~41	8~58	8~58	8~47	8~63	8~53	8~41	8~61	8~66	8~28	8~66	8~58	
標準フック	35t						12.2t								
フック質量	950kg						440kg								
標準巻掛本数	2						1								

カウンタウエイト 98t、アウトリガ張出幅 6.8m

PS+ブーム+2.5m+52.0m(ヘビー)LJ

単位:t

ブーム長さ	35.3m			40.4m			45.4m			50.5m			55.6m		
ブーム起伏角 作業半径(m)	83°	75°	68°	83°	75°	68°	83°	75°	68°	83°	75°	68°	83°	75°	
24.0	15.5														
26.0	15.3														
28.0	15.1			12.9			10.5			7.8					
30.0	14.9			12.7			10.3			7.7			5.4		
32.0	14.8			12.6			10.2			7.5			5.4		
34.0	14.6			12.4			10.1			7.4			5.3		
36.0	14.5	13.0		12.3			10.0			7.3			5.2		
38.0	14.4	11.9		12.0			9.9			7.2			5.1		
40.0	14.1	10.9		11.7	9.0		9.7	9.1		7.1			5.0		
42.0	13.2	10.0		10.9	8.2		9.6	8.3		7.0	7.0		4.9		
44.0	12.3	9.2		10.1	7.5		9.4	7.6		7.0	6.5	4.9	4.8		
46.0	11.5	8.5	5.7	9.4	6.9		8.7	6.9		6.9	5.9	4.8	4.7		
48.0	10.6	7.8	5.2	8.7	6.3		8.1	6.3		6.8	5.3	4.7	4.6		
50.0	9.8	7.2	4.7	8.1	5.7	3.0	7.4	5.8		6.7	4.8	4.7	4.4		
54.0		6.1	3.8		4.8	2.2	6.2	4.8	2.0	6.3	3.9	4.5	3.6		
58.0		5.2	3.1		4.0	1.6		4.0			3.2		2.9		
62.0			2.4					3.3			2.5		2.2		
θ(°)	8~56	8~56	8~48	8~55	8~52	8~34	8~64	8~62	8~23	8~62	8~57	8~60	8~52		
標準フック	35t						12.2t								
フック質量	950kg						440kg								
標準巻掛本数	2						1								

カウンタウエイト 98t、アウトリガ張出幅 6.8m

PS+ブーム+2.5m+46.0m(ライト)LJ

単位:t

ブーム長さ	35.3m			40.4m			45.4m			50.5m			55.6m		
ブーム起伏角 作業半径(m)	83°	75°	68°	83°	75°	68°	83°	75°	68°	83°	75°	68°	83°	75°	68°
22.0	17.7														
24.0	17.1														
26.0	16.4			14.2			12.6			9.3					
28.0	15.5			13.9			12.5			9.1			6.8		
30.0	14.5			13.7			12.3			9.0			6.7		
32.0	13.7			13.2			12.1			8.8			6.5		
34.0	12.8	14.9		12.6			11.9			8.7			6.4		
36.0	12.0	14.1		12.0	12.6		11.5			8.6			6.3		
38.0	11.3	13.2		11.3	11.6		11.1	10.9		8.4			6.2		
40.0	10.7	12.4		10.7	10.7		10.6	10.1		8.3	8.4		6.1		
42.0	10.1	11.5	8.6	10.1	9.9		10.2	9.3		8.2	8.2		6.0	5.9	
44.0	9.5	10.8	7.9	9.6	9.1		9.7	8.5		8.1	8.1		5.9	5.8	
46.0	9.0	10.0	7.3	9.1	8.4	5.5	9.1	7.9		7.9	7.7		5.7	5.7	
48.0		9.3	6.7		7.8	5.0	8.4	7.3	4.2	7.7	7.1		5.6	5.6	
50.0		8.7	6.2		7.2	4.5		6.7	3.8		6.6	3.4	5.5	5.5	
54.0			5.3		6.2	3.7		5.7	3.0		5.6	2.7	4.8	4.8	1.6
58.0					3.0				2.4		4.8	2.1	4.0	4.0	
62.0												1.5			
θ(°)	8~60	8~49	8~41	8~58	8~58	8~47	8~63	8~53	8~41	8~61	8~66	8~48	8~66	8~58	8~24
標準フック	35t						12.2t								
フック質量	950kg						440kg								
標準巻掛本数	2						1								

カウンタウエイト 98t、アウトリガ張出幅 6.8m

PS+ブーム+2.5m+52.0m(ライト)LJ

単位:t

ブーム長さ	35.3m			40.4m			45.4m			50.5m			55.6m		
ブーム起伏角 作業半径(m)	83°	75°	68°	83°	75°	68°	83°	75°	68°	83°	75°	68°	83°	75°	
26.0	14.0														
28.0	13.3			12.0			10.2			7.8					
30.0	12.7			11.6			10.1			7.6			5.6		
32.0	12.0			11.1			9.8			7.5			5.5		
34.0	11.4			10.5			9.6			7.4			5.4		
36.0	10.7			10.0			9.2			7.3			5.3		
38.0	10.1	11.7		9.5			8.9			7.2			5.2		
40.0	9.5	11.0		9.0	9.6		8.5	9.4		7.1			5.1		
42.0	9.0	10.4		8.5	8.8		8.2	9.0		7.1	7.0		5.1		
44.0	8.5	9.6		8.0	8.1		7.8	8.3		6.9	7.0		5.0	4.9	
46.0	8.0	8.9	6.1	7.6	7.4		7.4	7.6		6.7	6.6		4.9	4.8	
48.0	7.6	8.2	5.6	7.2	6.8		7.1	7.0		6.5	6.0		4.9	4.8	
50.0	7.2	7.6	5.1	6.8	6.3	3.6	6.8	6.5		6.3	5.5		4.8	4.7	
54.0		6.5	4.3		5.3	2.8	6.1	5.5	2.7	5.8	4.6	1.6	4.6	4.2	
58.0		5.6	3.5		4.5	2.2		4.7	1.3		3.9		4.5	3.5	
62.0			2.9			1.6		3.9	1.5		3.2			2.8	
θ(°)	8~56	8~56	8~48	8~55	8~52	8~43	8~64	8~62	8~38	8~62	8~57	8~20	8~60	8~52	
標準フック	35t						12.2t								
フック質量	950kg						440kg								
標準巻掛本数	2						1								

PS+ラフィングジブ

カウンタウエイト 78t、アウトリガ張出幅 8.5m

PS+ブーム+2.5m+20.3mLJ

ブーム長さ ブーム起伏角 作業半径 (m)	35.3m			40.4m			45.4m			単位:t	
	83°	75°	68°	83°	75°	68°	83°	75°	68°		
16.0	39.8										
18.0	35.5			31.1							
20.0	31.7			27.6			26.7				
22.0	28.0			22.0			21.5				
24.0		30.1					18.5				
26.0		27.2			21.4						
28.0		21.3			19.0						
30.0			19.9		16.5			16.4			
32.0			18.3								
34.0					15.3						
36.0										12.8	
θ(°)	18~58	18~57	18~47	18~54	18~67	18~48	18~64	18~52	18~48		
標準フック	80t			35t							
フック質量	1550kg			950kg							
標準巻掛本数	4			3							

カウンタウエイト 78t、アウトリガ張出幅 8.5m

PS+ブーム+2.5m+32.3mLJ

ブーム長さ ブーム起伏角 作業半径 (m)	35.3m			40.4m			45.4m			50.5m			単位:t
	83°	75°	68°	83°	75°	68°	83°	75°	68°	83°	75°	68°	
18.0	30.8												
20.0	30.3			20.8									
22.0	29.4			20.3			16.5			12.5			
24.0	26.9			19.9			16.1			12.1			
26.0	22.4			19.0			15.8			11.9			
28.0	20.4	22.6		17.5			15.6			11.7			
30.0	18.6	20.6		16.0	17.7		15.3			11.6			
32.0	16.9	18.9		14.5	16.2		13.9	15.1		11.3			
34.0	15.2	17.4	14.5	13.1	15.0		12.5	14.2		11.0	11.5		
36.0		16.1	13.4		13.8			13.0		11.0	11.2		
38.0		14.9	12.4		12.6	10.7		12.0			10.9		
40.0		13.4	11.4		11.5	9.8		11.0	8.1		10.7		
42.0			10.6		10.3	9.1		9.9	7.4		9.9		
44.0			9.8			8.4			6.8		9.1	5.6	
46.0						7.7			6.2			5.1	
48.0									5.7			4.7	
50.0												4.3	
θ(°)	8~64	8~61	8~52	8~60	8~69	8~53	8~58	8~57	8~53	8~65	8~62	8~54	
標準フック				35t									
フック質量				950kg									
標準巻掛本数	3						2						

カウンタウエイト 78t、アウトリガ張出幅 8.5m

PS+ブーム+2.5m+34.0mLJ

ブーム長さ ブーム起伏角 作業半径 (m)	35.3m			40.4m			45.4m			50.5m			55.6m			単位:t
	83°	75°	68°	83°	75°	68°	83°	75°	68°	83°	75°	68°	83°	75°	68°	
18.0	27.8															
20.0	24.4			19.8												
22.0	22.8			19.3			15.6									
24.0	21.2			18.9			15.2			11.5				7.9		
26.0	19.4			18.4			15.0			11.4				7.7		
28.0	17.7	21.2		17.6			14.7			11.4				7.7		
30.0	16.1	19.5		16.1	17.5		14.4			11.1				7.7		
32.0	14.6	18.0		14.6	16.3		13.8	14.4		11.0				7.7		
34.0	12.9	16.6		13.3	15.0		12.7	14.1		10.7	11.1			7.7		
36.0		15.3	12.9	12.0	13.8		11.4	13.2		10.6	10.8			7.5	7.2	
38.0		14.0	11.9		12.7	10.2		12.0			10.5			7.2	7.2	
40.0		12.8	10.9		11.7	9.4		11.0			10.4			7.0		
42.0		11.4	10.1		10.6	8.6		10.1	6.9		9.6			7.0		
44.0			9.3			7.9		9.1	6.3		8.8	5.3		7.0		
46.0			8.6			7.3			5.7		8.2	4.8		6.6	4.0	
48.0									5.2		7.4	4.4			3.6	
50.0									4.8		6.4	4.0			3.3	
54.0											4.0				2.6	
θ(°)	8~56	8~64	8~54	8~62	8~55	8~55	8~59	8~59	8~56	8~57	8~64	8~45	8~63	8~55	8~58	
標準フック				35t									12.2t			
フック質量				950kg									440kg			
標準巻掛本数	3						2						1			

カウンタウエイト 78t、アウトリガ張出幅 8.5m

PS+ブーム+2.5m+40.0mLJ

ブーム長さ ブーム起伏角 作業半径 (m)	35.3m			40.4m			45.4m			50.5m			55.6m			単位:t
	83°	75°	68°	83°	75°	68°	83°	75°	68°	83°	75°	68°	83°	75°	68°	
20.0	20.8															
22.0	20.4			17.2												
24.0	20.0			16.8			13.4									
26.0	19.6			16.5			13.2			10.3				8.2		
28.0	18.7			16.2			13.1			10.3				8.0		
30.0	17.7	19.1		15.9			13.0			10.2				7.8		
32.0	16.7	17.8		15.6			12.8			10.0				7.7		
34.0	15.7	16.3		15.0	14.8		12.7			9.8				7.5		
36.0	14.8	15.1		14.1	13.6		12.4	12.4		9.7				7.3		
38.0	14.0	13.9		13.0	12.6		11.3	11.4		9.6	9.7			7.2	7.3	
40.0	12.9	12.9	10.1	11.9	11.6		10.3	10.5		9.4	9.5			7.0	7.1	
42.0		12.0	9.3	10.8	10.8	7.5	9.3	9.7		9.2	8.9			6.9	6.9	
44.0		11.2	8.6		10.0	6.9		8.9	5.5		8.2			6.7	6.8	
46.0		10.5	7.9		9.2	6.3		8.2	5.0		7.6			6.6		
48.0		9.8	7.3		8.6	5.8		7.6	4.6		7.0			6.5		
50.0			6.8			5.3		7.0	4.1		6.4	3.7		6.3	2.9	
54.0									3.4					2.6	2.2	
58.0														2.0	1.7	
θ(°)	8~59	8~65	8~45	8~64	8~57	8~39	8~61	8~60	8~46	8~59	8~54	8~58	8~65	8~49	8~47	
標準フック				35t									12.2t			
フック質量				950kg									440kg			
標準巻掛本数				2									1			

カウンタウエイト 78t、アウトリガ張出幅 8.5m

PS+ブーム+2.5m+46.0m(ヘビー)LJ

単位:t

ブーム長さ	35.3m			40.4m			45.4m			50.5m			55.6m		
ブーム起伏角 作業半径(m)	83°	75°	68°	83°	75°	68°	83°	75°	68°	83°	75°	68°	83°	75°	
22.0	17.1														
24.0	16.8			14.0											
26.0	16.5			13.8			12.0			9.2					
28.0	16.2			13.7			11.8			9.0			6.6		
30.0	16.0			13.5			11.6			8.9			6.5		
32.0	15.7			13.3			11.5			8.7			6.3		
34.0	15.4	15.1		13.2			11.4			8.6			6.2		
36.0	14.8	13.8		13.0	12.1		11.2			8.5			6.1		
38.0	13.7	12.8		12.2	11.1		11.0			8.3			6.0		
40.0	12.7	11.8		11.3	10.1		10.6	9.1		8.2	8.2		5.9	5.7	
42.0	11.8	10.9	7.9	10.5	9.3		9.7	8.3		8.1	8.1		5.8	5.6	
44.0	10.9	10.0	7.1	9.6	8.5		8.9	7.6		7.9	7.5		5.7	5.5	
46.0	9.9	9.3	6.5	8.8	7.8	4.8	8.2	7.0		7.8	6.8		5.6	5.5	
48.0		8.6	6.0		7.2	4.3	7.5	6.4	3.2	7.5	6.3		5.5	5.3	
50.0		7.9	5.4		6.6	3.9		5.8	2.8		5.7	2.5	5.3	4.8	
54.0			4.5		5.6	3.1		4.9	2.1		4.8	1.8		3.9	
58.0						2.4			1.5		4.0			3.2	
θ(°)	8~60	8~49	8~41	8~58	8~58	8~47	8~63	8~53	8~41	8~61	8~66	8~28	8~66	8~58	
標準フック	35t						12.2t								
フック質量	950kg						440kg								
標準巻掛本数	2						1								

カウンタウエイト 78t、アウトリガ張出幅 8.5m

PS+ブーム+2.5m+52.0m(ヘビー)LJ

単位:t

ブーム長さ	35.3m			40.4m			45.4m			50.5m			55.6m		
ブーム起伏角 作業半径(m)	83°	75°	68°	83°	75°	68°	83°	75°	68°	83°	75°	68°	83°	75°	
24.0	15.5														
26.0	15.3														
28.0	15.1			12.9			10.5			7.8					
30.0	14.9			12.7			10.3			7.7			5.4		
32.0	14.8			12.6			10.2			7.5			5.4		
34.0	14.6			12.4			10.1			7.4			5.3		
36.0	14.5	12.9		12.3			10.0			7.3			5.2		
38.0	14.4	11.8		12.0			9.9			7.2			5.1		
40.0	14.1	10.8		11.7	8.9		9.7	8.9		7.1			5.0		
42.0	13.1	9.9		10.9	8.1		9.6	8.1		7.0	7.0		4.9		
44.0	12.2	9.1		10.1	7.4		9.4	7.4		7.0	6.3	4.9	4.8		
46.0	11.4	8.4	5.6	9.4	6.7		8.7	6.8		6.9	5.7	4.8	4.7		
48.0	10.6	7.7	5.0	8.7	6.2		8.1	6.2		6.8	5.2	4.7	4.6		
50.0	9.8	7.1	4.6	8.1	5.6	2.8	7.4	5.6		6.7	4.7	4.7	4.3		
54.0		6.0	3.7		4.7	2.1	6.2	4.7	1.9	6.3	3.8	4.5	3.5		
58.0		5.1	2.9		3.8	1.5		3.9			3.1		2.7		
62.0			2.3					3.1			2.4		2.1		
θ(°)	8~56	8~56	8~48	8~55	8~52	8~34	8~64	8~62	8~23	8~62	8~57	8~60	8~52		
標準フック	35t						12.2t								
フック質量	950kg						440kg								
標準巻掛本数	2						1								

カウンタウエイト 78t、アウトリガ張出幅 8.5m

PS+ブーム+2.5m+46.0m(ライト)LJ

単位:t

ブーム長さ	35.3m			40.4m			45.4m			50.5m			55.6m		
ブーム起伏角 作業半径(m)	83°	75°	68°	83°	75°	68°	83°	75°	68°	83°	75°	68°	83°	75°	
22.0	17.7														
24.0	17.1														
26.0	16.4			14.2			12.6			9.3					
28.0	15.5			13.9			12.5			9.1			6.8		
30.0	14.5			13.7			12.3			9.0			6.7		
32.0	13.7			13.2			12.1			8.8			6.5		
34.0	12.8	14.9		12.6			11.9			8.7			6.4		
36.0	12.0	14.1		12.0	12.5		11.5			8.6			6.3		
38.0	11.3	13.2		11.3	11.5		11.1	10.8		8.4			6.2		
40.0	10.7	12.3		10.7	10.5		10.6	9.9		8.3	8.4		6.1		
42.0	10.1	11.4	8.5	10.1	9.7		10.2	9.1		8.2	8.2		6.0	5.9	
44.0	9.5	10.6	7.8	9.6	9.0		9.7	8.4		8.1	8.1		5.9	5.8	
46.0	9.0	9.9	7.2	9.1	8.3	5.3	9.1	7.7		7.9	7.6		5.7	5.7	
48.0		9.2	6.6		7.7	4.8	8.4	7.1	4.0	7.7	7.0		5.6	5.6	
50.0		8.5	6.1		7.1	4.4		6.6	3.6	6.4	3.2		5.5	5.5	
54.0			5.1		6.1	3.6		5.6	2.9		5.5	2.5		4.6	
58.0						2.9			2.3		4.7	1.9		3.9	
θ(°)	8~60	8~49	8~41	8~58	8~58	8~47	8~63	8~53	8~41	8~61	8~66	8~36	8~66	8~58	
標準フック	35t						12.2t								
フック質量	950kg						440kg								
標準巻掛本数	2						1								

カウンタウエイト 78t、アウトリガ張出幅 8.5m

PS+ブーム+2.5m+52.0m(ライト)LJ

単位:t

ブーム長さ	35.3m			40.4m			45.4m			50.5m			55.6m		
ブーム起伏角 作業半径(m)	83°	75°	68°	83°	75°	68°	83°	75°	68°	83°	75°	68°	83°	75°	
26.0	14.0														
28.0	13.3			12.0			10.2			7.8					
30.0	12.7			11.6			10.1			7.6			5.6		
32.0	12.0			11.1			9.8			7.5			5.5		
34.0	11.4			10.5			9.6			7.4			5.4		
36.0	10.7			10.0			9.2			7.3			5.3		
38.0	10.1	11.7		9.5			8.9			7.2			5.2		
40.0	9.5	11.0		9.0	9.4		8.5	9.4		7.1			5.1		
42.0	9.0	10.2		8.5	8.7		8.2	8.8		7.1	7.0		5.1		
44.0	8.5	9.5		8.0	7.9		7.8	8.1		6.9	7.0		5.0	4.9	
46.0	8.0	8.7	6.0	7.6	7.3		7.4	7.5		6.7	6.4		4.9	4.8	
48.0	7.6	8.1	5.5	7.2	6.7		7.1	6.9		6.5	5.9		4.9	4.8	
50.0	7.2	7.5	5.0	6.8	6.2	3.4	6.8	6.3		6.3	5.4		4.8	4.7	
54.0		6.4	4.1		5.2	2.7	6.1	5.4	2.6	5.8	4.5	1.9	4.6	4.1	
58.0		5.5	3.4		4.4	2.1		4.5	1.9		3.7		3.3		
62.0			2.8			1.5		3.8			3.1			2.7	
θ(°)	8~56	8~56	8~48	8~55	8~52	8~43	8~64	8~62	8~30	8~62	8~57	8~20	8~60	8~52	
標準フック	35t						12.2t								
フック質量	950kg						440kg								
標準巻掛本数	2						1								

PS+ラフイングジブ

カウンタウエイト 78t、アウトリガ張出幅 8.0m

PS+ブーム+2.5m+20.3mLJ

ブーム長さ ブーム起伏角 作業半径 (m)	35.3m			40.4m			45.4m			単位:t	
	83°	75°	68°	83°	75°	68°	83°	75°	68°		
16.0	39.8										
18.0	35.5			31.1							
20.0	31.7			27.6			26.7				
22.0	28.0			22.0			21.5				
24.0		29.6					18.5				
26.0		26.6			21.4						
28.0		21.3			19.0						
30.0			18.9		16.5			16.4			
32.0			17.3								
34.0					14.4						
36.0									11.8		
θ(°)	18~58	18~57	18~47	18~54	18~67	18~48	18~64	18~52	18~48		
標準フック	80t			35t							
フック質量	1550kg			950kg							
標準巻掛本数	4			3							

カウンタウエイト 78t、アウトリガ張出幅 8.0m

PS+ブーム+2.5m+32.3mLJ

ブーム長さ ブーム起伏角 作業半径 (m)	35.3m			40.4m			45.4m			50.5m			単位:t	
	83°	75°	68°	83°	75°	68°	83°	75°	68°	83°	75°	68°		
18.0	30.8													
20.0	30.3			20.8										
22.0	29.4			20.3			16.5			12.5				
24.0	26.9			19.9			16.1			12.1				
26.0	22.4			19.0			15.8			11.9				
28.0	20.4	21.6		17.5			15.6			11.7				
30.0	18.6	19.6		16.0	17.7		15.3			11.6				
32.0	16.9	18.0		14.5	16.2		13.9	15.1		11.3				
34.0	15.2	16.5	13.6	13.1	15.0		12.5	13.9		11.0	11.5			
36.0		15.2	12.5		13.8			12.8		11.0	11.2			
38.0		14.1	11.5		12.6	9.8		11.8			10.7			
40.0		13.1	10.6		11.5	9.0		10.9	7.2		9.8			
42.0			9.7		10.3	8.2		9.9	6.6		9.1			
44.0			9.0			7.6			6.0		8.3	4.8		
46.0						7.0			5.5			4.4		
48.0									5.0			3.9		
50.0												3.5		
θ(°)	8~64	8~61	8~52	8~60	8~69	8~53	8~58	8~57	8~53	8~65	8~62	8~54		
標準フック				35t										
フック質量				950kg										
標準巻掛本数	3						2							

カウンタウエイト 78t、アウトリガ張出幅 8.0m

PS+ブーム+2.5m+34.0mLJ

ブーム長さ ブーム起伏角 作業半径 (m)	35.3m			40.4m			45.4m			50.5m			55.6m			単位:t	
	83°	75°	68°	83°	75°	68°	83°	75°	68°	83°	75°	68°	83°	75°	68°		
18.0	27.8																
20.0	24.4			19.8													
22.0	22.8			19.3			15.6										
24.0	21.2			18.9			15.2			11.5				7.9			
26.0	19.4			18.4			15.0			11.4				7.7			
28.0	17.7	21.1		17.6			14.7			11.4				7.7			
30.0	16.1	19.2		16.1	17.5		14.4			11.1				7.7			
32.0	14.6	17.5		14.6	16.2		13.8	14.4		11.0				7.7			
34.0	12.9	16.1		13.3	14.9		12.7	13.4		10.7	11.1			7.7			
36.0		14.8	12.0	12.0	13.7		11.4	12.3		10.6	10.8			7.5	7.2		
38.0		13.7	11.0		12.7	9.3		11.3			10.4			7.2	7.2		
40.0		12.7	10.1		11.7	8.5		10.3			9.5			7.0	7.0		
42.0		11.4	9.3		10.6	7.8		9.5	6.0		8.8			7.0	7.0		
44.0			8.5			7.1		8.8	5.5		8.1	4.5		7.0	7.0		
46.0			7.9			6.5			5.0	7.4	4.1			6.6	3.3		
48.0						6.0			4.5		3.6				2.9		
50.0									4.1		3.3				2.5		
54.0											3.3				1.9		
θ(°)	8~56	8~64	8~54	8~62	8~55	8~55	8~59	8~59	8~56	8~57	8~64	8~45	8~63	8~55	8~58		
標準フック				35t									12.2t				
フック質量				950kg									440kg				
標準巻掛本数	3						2						1				

カウンタウエイト 78t、アウトリガ張出幅 8.0m

PS+ブーム+2.5m+40.0mLJ

ブーム長さ ブーム起伏角 作業半径 (m)	35.3m			40.4m			45.4m			50.5m			55.6m			単位:t	
	83°	75°	68°	83°	75°	68°	83°	75°	68°	83°	75°	68°	83°	75°	68°		
20.0	20.8																
22.0	20.4			17.2													
24.0	20.0			16.8			13.4										
26.0	19.6			16.5			13.2			10.3				8.2			
28.0	18.7			16.2			13.1			10.3				8.0			
30.0	17.7	18.4		15.9			13.0			10.2				7.8			
32.0	16.7	16.8		15.6			12.8			10.0				7.7			
34.0	15.7	15.5		15.0	13.9		12.7			9.8				7.5			
36.0	14.8	14.2		14.1	12.8		12.4	11.5		9.7				7.3			
38.0	14.0	13.1		13.0	11.8		11.3	10.5		9.6	9.6			7.2	7.3		
40.0	12.9	12.2	9.3	11.9	10.8		10.3	9.7		9.4	8.8			7.0	7.1		
42.0		11.3	8.5	10.8	10.0	6.7	9.3	8.9		9.2	8.1			6.9	6.9		
44.0		10.5	7.8		9.2	6.1		8.2	4.7		7.4			6.7	6.8		
46.0		9.8	7.2		8.5	5.6		7.5	4.3		6.8			6.6	6.6		
48.0		9.1	6.6		7.9	5.1		6.9	3.8		6.2			2.9	6.1		
50.0			6.1			4.6		6.4	3.4		5.7			2.6	5.6	2.2	
54.0									2.7		2.7			1.9		1.6	
θ(°)	8~59	8~65	8~45	8~64	8~57	8~39	8~61	8~60	8~46	8~59	8~54	8~40	8~65	8~49	8~34		
標準フック				35t									12.2t				
フック質量				950kg									440kg				
標準巻掛本数				2									1				

カウンタウエイト 78t、アウトリガ張出幅 8.0m

PS+ブーム+2.5m+46.0m(ヘビー)LJ

単位:t

ブーム長さ	35.3m			40.4m			45.4m			50.5m			55.6m		
ブーム起伏角 作業半径(m)	83°	75°	68°	83°	75°	68°	83°	75°	68°	83°	75°	68°	83°	75°	
22.0	17.1														
24.0	16.8			14.0											
26.0	16.5			13.8			12.0			9.2					
28.0	16.2			13.7			11.8			9.0			6.6		
30.0	16.0			13.5			11.6			8.9			6.5		
32.0	15.7			13.3			11.5			8.7			6.3		
34.0	15.4	14.2		13.2			11.4			8.6			6.2		
36.0	14.8	13.0		13.0	11.2		11.2			8.5			6.1		
38.0	13.7	12.0		12.2	10.2		11.0	9.1		8.3			6.0		
40.0	12.7	11.0		11.3	9.3		10.6	8.3		8.2	8.1		5.9		
42.0	11.8	10.1	7.0	10.5	8.5		9.7	7.5		8.1	7.4		5.7	5.7	
44.0	10.9	9.3	6.4	9.6	7.8		8.9	6.8		7.9	6.7		5.6	5.6	
46.0	9.9	8.5	5.8	8.8	7.1	4.1	8.2	6.2		7.8	6.1		5.6	5.0	
48.0		7.9	5.2		6.5	3.6	7.5	5.7	2.5	7.5	5.6		5.5	4.5	
50.0		7.3	4.8		6.0	3.2		5.1	2.1		5.1	1.8	5.3	4.1	
54.0			3.9		5.0	2.4		4.2	1.5		4.2			3.3	
58.0						1.8					3.4			2.6	
θ(°)	8~60	8~49	8~41	8~58	8~58	8~47	8~63	8~53	8~32	8~61	8~66	8~21	8~66	8~58	
標準フック	35t						12.2t								
フック質量	950kg						440kg								
標準巻掛本数	2						1								

カウンタウエイト 78t、アウトリガ張出幅 8.0m

PS+ブーム+2.5m+46.0m(ライト)LJ

単位:t

ブーム長さ	35.3m			40.4m			45.4m			50.5m			55.6m		
ブーム起伏角 作業半径(m)	83°	75°	68°	83°	75°	68°	83°	75°	68°	83°	75°	68°	83°	75°	
22.0	17.7														
24.0	17.1														
26.0	16.4			14.2			12.6			9.3					
28.0	15.5			13.9			12.5			9.1			6.8		
30.0	14.5			13.7			12.3			9.0			6.7		
32.0	13.7			13.2			12.1			8.8			6.5		
34.0	12.8	14.6		12.6			11.9			8.7			6.4		
36.0	12.0	13.5		12.0	11.6		11.5			8.6			6.3		
38.0	11.3	12.4		11.3	10.6		11.1	9.9		8.4			6.2		
40.0	10.7	11.5		10.7	9.7		10.6	9.1		8.3	8.4		6.1		
42.0	10.1	10.7	7.7	10.1	8.9		10.2	8.3		8.2	8.1		6.0	5.9	
44.0	9.5	9.9	7.0	9.6	8.2		9.7	7.6		8.1	7.4		5.9	5.8	
46.0	9.0	9.1	6.4	9.1	7.6	4.5	9.1	7.0		7.9	6.8		5.7	5.7	
48.0		8.5	5.9		7.0	4.1	8.4	6.4	3.3	7.7	6.3		5.6	5.3	
50.0		7.9	5.4		6.4	3.7		5.9	2.9		5.8	2.5	5.5	4.8	
54.0		4.5	4.5		5.4	3.0		5.0	2.2		4.8	1.9		4.0	
58.0						2.3			1.7		4.1			3.3	
θ(°)	8~60	8~49	8~41	8~58	8~58	8~47	8~63	8~53	8~41	8~61	8~66	8~28	8~66	8~58	
標準フック	35t						12.2t								
フック質量	950kg						440kg								
標準巻掛本数	2						1								

カウンタウエイト 78t、アウトリガ張出幅 8.0m

PS+ブーム+2.5m+52.0m(ライト)LJ

単位:t

ブーム長さ	35.3m			40.4m			45.4m			50.5m			55.6m		
ブーム起伏角 作業半径(m)	83°	75°	68°	83°	75°	68°	83°	75°	68°	83°	75°	68°	83°	75°	
26.0	14.0														
28.0	13.3			12.0			10.2			7.8					
30.0	12.7			11.6			10.1			7.6			5.6		
32.0	12.0			11.1			9.8			7.5			5.5		
34.0	11.4			10.5			9.6			7.4			5.4		
36.0	10.7			10.0			9.2			7.3			5.3		
38.0	10.1	11.2		9.5			8.9			7.2			5.2		
40.0	9.5	10.3		9.0	8.6		8.5	8.8		7.1			5.1		
42.0	9.0	9.5		8.5	7.9		8.2	8.0		7.1	6.9		5.1		
44.0	8.5	8.7		8.0	7.2		7.8	7.4		6.9	6.2	5.0	4.9		
46.0	8.0	8.0	5.2	7.6	6.6		7.4	6.7		6.7	5.7	4.9	4.8		
48.0	7.6	7.4	4.7	7.2	6.0		7.1	6.2		6.5	5.2	4.9	4.7		
50.0	7.2	6.8	4.3	6.8	5.5	2.7	6.8	5.7		6.3	4.7	4.8	4.2		
54.0		5.8	3.5		4.6	2.0	6.1	4.7	1.9	5.8	3.9	4.6	3.4		
58.0		4.9	2.8		3.8	1.5		4.0			3.1		2.8		
62.0			2.2					3.3			2.5		2.2		
θ(°)	8~56	8~56	8~48	8~55	8~52	8~34	8~64	8~62	8~23	8~62	8~57	8~60	8~52		
標準フック	35t						12.2t								
フック質量	950kg						440kg								
標準巻掛本数	2						1								

PS+ラフィングジブ

カウンタウエイト 78t、アウトリガ張出幅 6.8m
PS+ブーム+2.5m+20.3mLJ

ブーム長さ ブーム起伏角 作業半径 (m)	35.3m			40.4m			45.4m			単位:t
	83°	75°	68°	83°	75°	68°	83°	75°	68°	
16.0	39.8									
18.0	35.5			31.1						
20.0	31.7			27.6			26.7			
22.0	28.0			22.0			21.5			
24.0		24.9					18.5			
26.0		22.4			20.6					
28.0		20.3			18.7					
30.0			15.5		16.5			15.8		
32.0			14.2							
34.0						11.4				
36.0										8.8
θ(°)	18~58	18~57	18~47	18~54	18~67	18~48	18~64	18~52	18~48	
標準フック	80t			35t						
フック質量	1550kg			950kg						
標準巻掛本数	4			3						

カウンタウエイト 78t、アウトリガ張出幅 6.8m
PS+ブーム+2.5m+32.3mLJ

ブーム長さ ブーム起伏角 作業半径 (m)	35.3m			40.4m			45.4m			50.5m			単位:t
	83°	75°	68°	83°	75°	68°	83°	75°	68°	83°	75°	68°	
18.0	30.8												
20.0	30.3			20.8									
22.0	29.4			20.3			16.5			12.5			
24.0	26.7			19.9			16.1			12.1			
26.0	22.4			19.0			15.8			11.9			
28.0	20.4	17.8		17.5			15.6			11.7			
30.0	18.6	16.2		16.0	14.8		15.3			11.6			
32.0	16.9	14.8		14.5	13.5		13.9	11.8		11.3			
34.0	15.2	13.6	10.4	13.1	12.4		12.5	10.7		11.0	9.5		
36.0		12.5	9.4		11.4			9.8		11.0	8.6		
38.0		11.5	8.6		10.4	6.9		8.9			7.9		
40.0		10.7	7.9		9.6	6.3		8.2	4.6		7.2		
42.0			7.2		8.8	5.7		7.5	4.1		6.5		
44.0			6.6			5.2			3.6		6.0	2.5	
46.0						4.7			3.2			2.1	
48.0									2.9			1.8	
50.0												1.5	
θ(°)	8~64	8~61	8~52	8~60	8~69	8~53	8~58	8~57	8~53	8~65	8~62	8~54	
標準フック	35t												
フック質量	950kg												
標準巻掛本数	3						2						

カウンタウエイト 78t、アウトリガ張出幅 6.8m
PS+ブーム+2.5m+34.0mLJ

ブーム長さ ブーム起伏角 作業半径 (m)	35.3m			40.4m			45.4m			50.5m			55.6m		単位:t
	83°	75°	68°	83°	75°	68°	83°	75°	68°	83°	75°	68°	83°	75°	
18.0	27.8														
20.0	24.4			19.8											
22.0	22.8			19.3			15.6								
24.0	21.2			18.9			15.2			11.5				7.9	
26.0	19.4			18.4			15.0			11.4				7.7	
28.0	17.7	17.3		17.6			14.7			11.4				7.7	
30.0	16.1	15.7		16.1	14.4		14.4			11.1				7.7	
32.0	14.6	14.4		14.6	13.1		13.8	11.2		11.0				7.7	
34.0	12.9	13.2		13.3	11.9		12.7	10.1		10.7	9.2			7.7	
36.0		12.1	8.9	12.0	10.9		11.4	9.2		10.6	8.3			7.5	7.2
38.0		11.2	8.1		10.0	6.5		8.4		7.6				7.2	6.8
40.0		10.3	7.4		9.1	5.8		7.6		6.9				6.2	6.2
42.0		9.5	6.7		8.4	5.3		7.0	3.5	6.2				5.6	5.6
44.0			6.1			4.7		6.4	3.1	5.7	2.2			5.1	5.1
46.0			5.6			4.3			2.7	5.2	1.8			4.6	4.6
48.0						3.8			2.4		1.5				
50.0									2.0						
θ(°)	8~56	8~64	8~54	8~62	8~55	8~55	8~59	8~59	8~56	8~57	8~64	8~37	8~63	8~55	
標準フック	35t						12.2t						440kg		
フック質量	950kg														
標準巻掛本数	3						2						1		

カウンタウエイト 78t、アウトリガ張出幅 6.8m
PS+ブーム+2.5m+40.0mLJ

ブーム長さ ブーム起伏角 作業半径 (m)	35.3m			40.4m			45.4m			50.5m		55.6m		単位:t	
	83°	75°	68°	83°	75°	68°	83°	75°	68°	83°	75°	68°	75°		
20.0	20.8														
22.0	20.4			17.2											
24.0	20.0			16.8			13.4								
26.0	19.6			16.5			13.2			10.3			8.2		
28.0	18.7			16.2			13.1			10.3			8.0		
30.0	17.7	15.0		15.9			13.0			10.2			7.8		
32.0	16.7	13.7		15.6			12.8			10.0			7.7		
34.0	15.7	12.5		14.9	10.7		12.7			9.8			7.5		
36.0	14.6	11.5		13.7	9.7		12.4	8.4		9.7			7.3		
38.0	13.5	10.5		12.6	8.9		11.3	7.7		9.6	6.8	7.2	6.6		
40.0	12.6	9.7	6.6	11.7	8.1		10.3	7.0		9.4	6.1	7.0	5.9		
42.0		8.9	6.0	10.8	7.4	4.2	9.3	6.3		9.2	5.5	6.9	5.4		
44.0		8.2	5.4		6.8	3.7		5.7	2.4	5.0	6.7	4.8	4.8		
46.0		7.5	4.9		6.2	3.3		5.2	2.0	4.5	4.5	4.4	4.4		
48.0		6.9	4.4		5.7	2.9		4.7	1.7	4.1	4.1	3.9	3.9		
50.0			4.0			2.5		4.3		3.7		3.5	3.5		
θ(°)	8~59	8~65	8~46	8~64	8~57	8~39	8~61	8~60	8~29	8~59	8~54	8~65	8~49		
標準フック	35t						12.2t						440kg		
フック質量	950kg														
標準巻掛本数				2						1					

カウンタウエイト 78t、アウトリガ張出幅 6.8m

PS+ブーム+2.5m+46.0m(ヘビー)LJ

単位:t

ブーム長さ ブーム起伏角 作業半径(m)	35.3m			40.4m			45.4m		50.5m		55.6m	
	83°	75°	68°	83°	75°	68°	83°	75°	83°	75°	83°	75°
22.0	17.1											
24.0	16.8			14.0								
26.0	16.5			13.8			12.0		9.2			
28.0	16.2			13.7			11.8		9.0		6.6	
30.0	16.0			13.5			11.6		8.9		6.5	
32.0	15.7			13.3			11.5		8.7		6.3	
34.0	14.8	11.0		13.2			11.4		8.6		6.2	
36.0	13.6	10.0		12.5	8.1		11.2		8.5		6.1	
38.0	12.5	9.0		11.5	7.3		11.0	6.2	8.3		6.0	
40.0	11.6	8.2		10.6	6.6		10.1	5.6	8.2	5.4	5.9	
42.0	10.7	7.5	4.5	9.8	5.9		9.3	5.0	8.1	4.8	5.8	3.7
44.0	10.0	6.8	4.0	9.1	5.3		8.5	4.4	7.9	4.3	5.7	3.2
46.0	9.3	6.2	3.5	8.3	4.8	1.8	7.8	3.9	7.8	3.8	5.6	2.8
48.0		5.7	3.1		4.3	1.5	7.2	3.5	7.4	3.4	5.5	2.4
50.0		5.1	2.7		3.9			3.1		3.0	5.3	2.0
54.0			2.0		3.1			2.3		2.2		
58.0											1.6	
θ(°)	8~60	8~49	8~41	8~58	8~58	8~24	8~63	8~53	8~61	8~66	8~66	8~36
標準フック	35t						12.2t					
フック質量	950kg						440kg					
標準巻掛本数	2						1					

カウンタウエイト 78t、アウトリガ張出幅 6.8m

PS+ブーム+2.5m+46.0m(ライト)LJ

単位:t

ブーム長さ ブーム起伏角 作業半径(m)	35.3m			40.4m			45.4m		50.5m		55.6m	
	83°	75°	68°	83°	75°	68°	83°	75°	83°	75°	83°	75°
22.0	17.7											
24.0	17.1											
26.0	16.4			14.2			12.6		9.3			
28.0	15.5			13.9			12.5		9.1		6.8	
30.0	14.5			13.7			12.3		9.0		6.7	
32.0	13.7			13.2			12.1		8.8		6.5	
34.0	12.8	11.6		12.6			11.9		8.7		6.4	
36.0	12.0	10.6		12.0	8.5		11.5		8.6		6.3	
38.0	11.3	9.7		11.3	7.7		11.1	7.0	8.4		6.2	
40.0	10.7	8.8		10.7	7.0		10.6	6.4	8.3	6.1	6.1	
42.0	10.1	8.1	5.1	10.1	6.4		10.0	5.8	8.2	5.6	6.0	4.4
44.0	9.5	7.4	4.6	9.4	5.8		9.3	5.2	8.1	5.0	5.9	3.9
46.0	9.0	6.8	4.1	8.8	5.3	2.3	8.6	4.7	7.9	4.5	5.7	3.5
48.0		6.3	3.7		4.8	1.9	7.9	4.3	7.7	4.1	5.6	3.1
50.0		5.8	3.3		4.3	1.6		3.8		3.7	5.5	2.7
54.0			2.6		3.5			3.1		2.9		2.1
58.0									2.3			1.5
θ(°)	8~60	8~49	8~41	8~58	8~58	8~27	8~63	8~53	8~61	8~66	8~66	8~58
標準フック	35t						12.2t					
フック質量	950kg						440kg					
標準巻掛本数	2						1					

PS+ラフィングジブ

カウンタウエイト 58t、アウトリガ張出幅 8.5m
PS+ブーム+2.5m+20.3mLJ

ブーム長さ ブーム起伏角 作業半径 (m)	35.3m			40.4m			45.4m			単位:t	
	83°	75°	68°	83°	75°	68°	83°	75°	68°		
16.0	39.8										
18.0	35.5			31.1							
20.0	31.7			27.6			26.7				
22.0	28.0			22.0			21.5				
24.0		24.5					18.5				
26.0		22.0			20.2						
28.0		19.9			18.3						
30.0			15.1		16.5			15.4			
32.0			13.8								
34.0						11.0					
36.0										8.4	
θ(°)	18~58	18~57	18~47	18~54	18~67	18~48	18~64	18~52	18~48		
標準フック	80t			35t							
フック質量	1550kg			950kg							
標準巻掛本数	4			3							

カウンタウエイト 58t、アウトリガ張出幅 8.5m
PS+ブーム+2.5m+32.3mLJ

ブーム長さ ブーム起伏角 作業半径 (m)	35.3m			40.4m			45.4m			50.5m			単位:t	
	83°	75°	68°	83°	75°	68°	83°	75°	68°	83°	75°	68°		
18.0	30.8													
20.0	30.3			20.8										
22.0	29.4			20.3			16.5			12.5				
24.0	26.3			19.9			16.1			12.1				
26.0	22.4			19.0			15.8			11.9				
28.0	20.4	17.4		17.5			15.6			11.7				
30.0	18.6	15.8		16.0	14.4		15.3			11.6				
32.0	16.9	14.4		14.5	13.1		13.9	11.4		11.3				
34.0	15.2	13.2	10.0	13.1	12.0		12.5	10.3		11.0	9.1			
36.0	12.2	9.1		11.0			9.4			11.0	8.2			
38.0		11.2	8.2		10.1	6.5		8.5			7.4			
40.0		10.3	7.5		9.2	5.9		7.8	4.1		6.8			
42.0			6.8		8.5	5.3		7.1	3.6		6.1			
44.0			6.2					4.8			3.2	5.6	2.0	
46.0						4.3					2.8		1.7	
48.0											2.5			
θ(°)	8~64	8~61	8~52	8~60	8~69	8~53	8~58	8~57	8~53	8~65	8~62	8~35		
標準フック				35t										
フック質量				950kg										
標準巻掛本数	3						2							

カウンタウエイト 58t、アウトリガ張出幅 8.5m
PS+ブーム+2.5m+34.0mLJ

ブーム長さ ブーム起伏角 作業半径 (m)	35.3m			40.4m			45.4m			50.5m			55.6m		単位:t
	83°	75°	68°	83°	75°	68°	83°	75°	68°	83°	75°	68°	83°	75°	
18.0	27.8														
20.0	24.4			19.8											
22.0	22.8			19.3			15.6								
24.0	21.2			18.9			15.2			11.5				7.9	
26.0	19.4			18.4			15.0			11.4				7.7	
28.0	17.7	16.9		17.6			14.7			11.4				7.7	
30.0	16.1	15.4		16.1	14.0		14.4			11.1				7.7	
32.0	14.6	14.0		14.6	12.7		13.8	10.8		11.0				7.7	
34.0	12.9	12.8		13.3	11.6		12.7	9.7		10.7	8.8			7.7	
36.0		11.7	8.5	12.0	10.5		11.4	8.8		10.6	7.9			7.5	7.1
38.0		10.8	7.7		9.6	6.0		8.0			7.2			7.2	6.4
40.0		10.0	7.0		8.8	5.4		7.3			6.5				5.8
42.0		9.2	6.4		8.0	4.9		6.6	3.1		5.9				5.2
44.0			5.8			4.4		6.0	2.7		5.3	1.7			4.7
46.0			5.2			3.9			2.3		4.8				4.2
48.0						3.5					2.0				
50.0											1.6				
θ(°)	8~56	8~64	8~54	8~62	8~55	8~55	8~59	8~59	8~56	8~57	8~64	8~26	8~63	8~55	
標準フック				35t						12.2t					
フック質量				950kg						440kg					
標準巻掛本数	3						2						1		

カウンタウエイト 58t、アウトリガ張出幅 8.5m
PS+ブーム+2.5m+40.0mLJ

ブーム長さ ブーム起伏角 作業半径 (m)	35.3m			40.4m			45.4m			50.5m		55.6m		単位:t	
	83°	75°	68°	83°	75°	68°	83°	75°	68°	83°	75°	68°	75°		
20.0	20.8														
22.0	20.4			17.2											
24.0	20.0			16.8			13.4								
26.0	19.6			16.5			13.2			10.3			8.2		
28.0	18.7			16.2			13.1			10.3			8.0		
30.0	17.7	14.6		15.9			13.0			10.2			7.8		
32.0	16.7	13.3		15.6			12.8			10.0			7.7		
34.0	15.5	12.2		14.5	10.3		12.7			9.8			7.5		
36.0	14.3	11.1		13.4	9.4		12.4	8.1		9.7			7.3		
38.0	13.2	10.2		12.3	8.5		11.3	7.3		9.6	6.4	7.2	6.2		
40.0	12.3	9.4	6.2	11.4	7.8		10.3	6.6		9.4	5.7	7.0	5.5		
42.0		8.6	5.6	10.6	7.1	3.8	9.3	5.9		9.2	5.2	6.9	5.0		
44.0		7.9	5.1		6.4	3.3		5.4	2.0		4.6	6.7	4.4		
46.0		7.2	4.6		5.9	2.9		4.9	1.6		4.2		4.0		
48.0		6.6	4.1		5.3	2.5		4.4			3.7		3.6		
50.0			3.7			2.2		3.9			3.3		3.2		
θ(°)	8~59	8~65	8~46	8~64	8~57	8~39	8~61	8~60	8~24	8~59	8~54	8~65	8~49		
標準フック				35t						12.2t					
フック質量				950kg						440kg					
標準巻掛本数				2						1					

カウンタウエイト 58t、アウトリガ張出幅 8.5m

PS+boom+2.5m+46.0m(ライト)LJ

単位:t

boom長さ boom起伏角 作業半径(m)	35.3m			40.4m			45.4m			50.5m		55.6m	
	83°	75°	68°	83°	75°	68°	83°	75°	83°	75°	83°	75°	
22.0	17.7												
24.0	17.1												
26.0	16.4			14.2			12.6		9.3				
28.0	15.5			13.9			12.5		9.1		6.8		
30.0	14.5			13.7			12.3		9.0		6.7		
32.0	13.7			13.2			12.1		8.8		6.5		
34.0	12.8	11.2		12.6			11.9		8.7		6.4		
36.0	12.0	10.2		12.0	8.1		11.5		8.6		6.3		
38.0	11.3	9.3		11.3	7.4		11.1	6.7	8.4		6.2		
40.0	10.7	8.5		10.6	6.6		10.4	6.0	8.3	5.8	6.1		
42.0	10.1	7.8	4.7	9.8	6.0		9.7	5.4	8.2	5.2	6.0	4.0	
44.0	9.5	7.1	4.2	9.1	5.4		9.0	4.8	8.1	4.7	5.9	3.5	
46.0	9.0	6.5	3.8	8.5	4.9	1.9	8.3	4.4	7.9	4.2	5.7	3.1	
48.0		6.0	3.4		4.4	1.6	7.6	3.9	7.7	3.7	5.6	2.7	
50.0		5.4	3.0		4.0			3.5		3.3	5.5	2.4	
54.0			2.3		3.2			2.8		2.6		1.7	
58.0										2.0			
θ(°)	8~60	8~49	8~41	8~58	8~58	8~24	8~63	8~53	8~61	8~66	8~66	8~45	
標準フック	35t						12.2t						
フック質量	950kg						440kg						
標準巻掛本数	2						1						

PS+ラフィングジブ

カウンタウエイト 58t、アウトリガ張出幅 8.0m

PS+ブーム+2.5m+20.3mLJ

ブーム長さ ブーム起伏角 作業半径 (m)	35.3m			40.4m			45.4m			単位:t	
	83°	75°	68°	83°	75°	68°	83°	75°	68°		
16.0	39.8										
18.0	35.5			31.1							
20.0	31.7			27.6			26.7				
22.0	28.0			22.0			21.5				
24.0		23.0					18.5				
26.0		20.6			18.8						
28.0		18.6			17.0						
30.0			13.8		15.4			14.1			
32.0			12.6								
34.0						9.8					
36.0									7.2		
θ(°)	18~58	18~57	18~47	18~54	18~67	18~48	18~64	18~52	18~48		
標準フック	80t			35t							
フック質量	1550kg			950kg							
標準巻掛本数	4			3							

カウンタウエイト 58t、アウトリガ張出幅 8.0m

PS+ブーム+2.5m+32.3mLJ

ブーム長さ ブーム起伏角 作業半径 (m)	35.3m			40.4m			45.4m			50.5m		単位:t
	83°	75°	68°	83°	75°	68°	83°	75°	68°	83°	75°	
18.0	30.8											
20.0	30.3			20.8								
22.0	28.1			20.3			16.5				12.5	
24.0	24.9			19.9			16.1				12.1	
26.0	22.3			19.0			15.8				11.9	
28.0	20.1	16.1		17.5			15.6				11.7	
30.0	18.3	14.6		16.0	13.2		15.3				11.6	
32.0	16.7	13.3		14.5	12.0		13.9	10.1			11.3	
34.0	15.2	12.1	8.8	13.1	10.9		12.5	9.1			11.0	7.9
36.0	11.1	7.9		9.9			8.3				11.0	7.1
38.0		10.2	7.2		9.0	5.5		7.5				6.4
40.0		9.4	6.5		8.2	4.9		6.8	3.1			5.8
42.0			5.9		7.5	4.4		6.2	2.7			5.2
44.0			5.3			3.9			2.3			4.7
46.0						3.5			2.0			4.2
48.0									1.7			3.7
θ(°)	8~64	8~61	8~52	8~60	8~69	8~53	8~58	8~57	8~53	8~65	8~62	
標準フック				35t								
フック質量				950kg								
標準巻掛本数	3						2					

カウンタウエイト 58t、アウトリガ張出幅 8.0m

PS+ブーム+2.5m+34.0mLJ

ブーム長さ ブーム起伏角 作業半径 (m)	35.3m			40.4m			45.4m			50.5m		55.6m		単位:t
	83°	75°	68°	83°	75°	68°	83°	75°	68°	83°	75°	83°	75°	
18.0	27.8													
20.0	24.4			19.8										
22.0	22.8			19.3			15.6							
24.0	21.2			18.9			15.2			11.5			7.9	
26.0	19.4			18.4			15.0			11.4			7.7	
28.0	17.7	15.6		17.6			14.7			11.4			7.7	
30.0	16.1	14.1		16.1	12.7		14.4			11.1			7.7	
32.0	14.6	12.8		14.6	11.5		13.8	9.5		11.0			7.7	
34.0	12.9	11.7		13.3	10.4		12.7	8.5		10.7	7.6		7.7	
36.0		10.7	7.4	12.0	9.4		11.4	7.7		10.6	6.8	7.5	6.0	
38.0		9.9	6.7		8.6	5.0		6.9			6.1	7.2	5.4	
40.0		9.0	6.0		7.8	4.4		6.3			5.5		4.8	
42.0		8.3	5.4		7.1	3.9		5.7	2.2		4.9		4.3	
44.0			4.9			3.5		5.1	1.8		4.4		3.8	
46.0			4.4			3.0			1.5		3.9		3.4	
48.0						2.7							3.0	
θ(°)	8~56	8~64	8~54	8~62	8~55	8~55	8~59	8~59	8~37	8~57	8~64	8~63	8~55	
標準フック				35t						12.2t				
フック質量				950kg						440kg				
標準巻掛本数	3						2					1		

カウンタウエイト 58t、アウトリガ張出幅 8.0m

PS+ブーム+2.5m+40.0mLJ

ブーム長さ ブーム起伏角 作業半径 (m)	35.3m			40.4m			45.4m			50.5m		55.6m		単位:t
	83°	75°	68°	83°	75°	68°	83°	75°	68°	83°	75°	83°	75°	
20.0	20.8													
22.0	20.4			17.2										
24.0	20.0			16.8			13.4							
26.0	19.6			16.5			13.2			10.3			8.2	
28.0	18.7			16.2			13.1			10.3			8.0	
30.0	17.3	13.4		15.9			13.0			10.2			7.8	
32.0	15.7	12.1		14.7			12.8			10.0			7.7	
34.0	14.4	11.1		13.5	9.1		12.7			9.8			7.5	
36.0	13.2	10.0		12.4	8.2		11.7	6.9		9.7			7.3	
38.0	12.2	9.1		11.4	7.5		10.8	6.2		9.6	5.3		7.2	5.1
40.0	11.4	8.3	5.2	10.5	6.7		9.9	5.6		9.4	4.7		7.0	4.5
42.0		7.6	4.7	9.7	6.1	2.8	9.2	5.0	8.8	4.2			6.9	4.0
44.0		7.0	4.2		5.5	2.4		4.5		3.7			6.7	3.6
46.0		6.4	3.7		5.0	2.1		4.0		3.3			6.5	3.1
48.0		5.8	3.3		4.5	1.7		3.6		2.9			6.3	2.8
50.0			2.9					3.2		2.5			6.1	2.4
θ(°)	8~59	8~65	8~46	8~64	8~57	8~34	8~61	8~60	8~59	8~54	8~65	8~49		
標準フック				35t						12.2t				
フック質量				950kg						440kg				
標準巻掛本数				2						1				

カウンタウエイト 47t、アウトリガ張出幅 8.5m

PS+ブーム+2.5m+20.3mLJ

ブーム長さ ブーム起伏角 作業半径(m)	35.3m			40.4m			45.4m			単位:t	
	83°	75°	68°	83°	75°	68°	83°	75°	68°		
16.0	39.8										
18.0	35.5			31.1							
20.0	31.7			27.6			26.7				
22.0	28.0			22.0			21.5				
24.0		21.0					18.5				
26.0		18.8			17.0						
28.0		16.9			15.3						
30.0			12.2		13.8			12.5			
32.0			11.1								
34.0						8.2					
36.0									5.8		
θ(°)	18~58	18~57	18~47	18~54	18~67	18~48	18~64	18~52	18~48		
標準フック	80t			35t							
フック質量	1550kg			950kg							
標準巻掛本数	4			3							

カウンタウエイト 47t、アウトリガ張出幅 8.5m

PS+ブーム+2.5m+32.3mLJ

ブーム長さ ブーム起伏角 作業半径(m)	35.3m			40.4m			45.4m			50.5m		単位:t		
	83°	75°	68°	83°	75°	68°	83°	75°	68°	83°	75°			
18.0	30.8													
20.0	29.5			20.8										
22.0	25.9			20.3			16.5				12.5			
24.0	22.9			19.9			16.1				12.1			
26.0	20.5			19.0			15.8				11.9			
28.0	18.4	14.4		17.5			15.6				11.7			
30.0	16.7	13.0		15.9	11.5		14.8				11.6			
32.0	15.2	11.8		14.5	10.4		13.5	8.4			11.3			
34.0	13.9	10.8	7.2	13.1	9.3		12.3	7.6			11.0	6.3		
36.0		9.8	6.5		8.4			6.8			10.7	5.6		
38.0		9.0	5.8		7.7	4.1		6.1				5.0		
40.0		8.2	5.2		6.9	3.6		5.5	1.8			4.5		
42.0			4.7		6.3	3.1		4.9	1.5			4.0		
44.0			4.2				2.7					3.5		
46.0						2.3								
48.0														
θ(°)	8~64	8~61	8~52	8~60	8~69	8~53	8~58	8~57	8~29	8~65	8~62			
標準フック	35t													
フック質量	950kg													
標準巻掛本数	3						2							

カウンタウエイト 47t、アウトリガ張出幅 8.5m

PS+ブーム+2.5m+34.0mLJ

ブーム長さ ブーム起伏角 作業半径(m)	35.3m			40.4m			45.4m			50.5m		55.6m		単位:t
	83°	75°	68°	83°	75°	68°	83°	75°	68°	83°	75°	83°	75°	
18.0	27.8													
20.0	24.4			19.8										
22.0	22.8			19.3			15.6							
24.0	21.2			18.9			15.2			11.5			7.9	
26.0	19.4			18.4			15.0			11.4			7.7	
28.0	17.7	13.9		17.2			14.7			11.4			7.7	
30.0	16.1	12.6		15.6	11.0		14.3			11.1			7.7	
32.0	14.6	11.4		14.1	9.8		13.0	7.8		11.0			7.7	
34.0	12.9	10.3		12.9	8.8		11.9	7.0	10.7		6.0		7.7	
36.0		9.4	5.9	11.9	8.0		10.9	6.2	10.5	5.3	7.5		4.5	
38.0		8.5	5.3		7.2	3.6		5.6		4.7	7.2		4.0	
40.0		7.7	4.7		6.5	3.1		5.0		4.2			3.5	
42.0		7.0	4.2		5.9	2.7		4.4		3.7			3.0	
44.0			3.7			2.3		3.9		3.2			2.6	
46.0			3.2			1.9				2.8			2.2	
48.0						1.6								
θ(°)	8~56	8~64	8~54	8~62	8~55	8~55	8~59	8~59	8~57	8~64	8~63	8~55		
標準フック	35t						12.2t							
フック質量	950kg						440kg							
標準巻掛本数	3						2			1				

カウンタウエイト 47t、アウトリガ張出幅 8.5m

PS+ブーム+2.5m+40.0mLJ

ブーム長さ ブーム起伏角 作業半径(m)	35.3m			40.4m			45.4m			50.5m		55.6m		単位:t
	83°	75°	68°	83°	75°	68°	83°	75°	68°	83°	75°	83°	75°	
20.0	20.8													
22.0	20.4			17.2										
24.0	20.0			16.8			13.4							
26.0	19.4			16.5			13.2			10.3			8.2	
28.0	17.4			16.2			13.1			10.3			8.0	
30.0	15.7	11.8		14.6			13.0			10.2			7.8	
32.0	14.3	10.6		13.3			12.5			10.0			7.7	
34.0	13.0	9.5		12.1	7.6		11.4			9.8			7.5	
36.0	12.0	8.6		11.1	6.8		10.4	5.5	9.7				7.3	
38.0	11.0	7.8		10.2	6.1		9.5	4.8	9.1	3.9	7.2		3.7	
40.0	10.3	7.1	3.9	9.3	5.4		8.8	4.3	8.3	3.4	7.0		3.2	
42.0		6.4	3.4	8.6	4.9	1.6	8.0	3.8	7.5	3.0	6.9		2.8	
44.0		5.8	3.0		4.4			3.3		2.6	6.7		2.4	
46.0		5.2	2.6		3.9			2.9		2.2			2.0	
48.0		4.7	2.2		3.4			2.5		1.8			1.7	
50.0			1.9					2.1		1.5				
θ(°)	8~59	8~65	8~46	8~64	8~57	8~20	8~61	8~60	8~58	8~54	8~65	8~43		
標準フック	35t						12.2t							
フック質量	950kg						440kg							
標準巻掛本数	2						1							

PS+ラフィングジブ

カウンタウエイト 47t、アウトリガ張出幅 8.0m
PS+ブーム+2.5m+20.3mLJ

ブーム長さ ブーム起伏角 作業半径 (m)	35.3m			40.4m			45.4m			単位:t
	83°	75°	68°	83°	75°	68°	83°	75°	68°	
16.0	39.8									
18.0	35.0			31.1						
20.0	30.3			27.6			26.7			
22.0	26.6			22.0			21.5			
24.0		19.4					18.5			
26.0		17.4			15.6					
28.0		15.6			14.0					
30.0			11.1		12.7				11.4	
32.0			10.0							
34.0						7.1				
36.0										4.8
θ(°)	18~58	18~57	18~47	18~54	18~67	18~48	18~64	18~52	18~48	
標準フック	80t			35t						
フック質量	1550kg			950kg						
標準巻掛本数	4			3						

カウンタウエイト 47t、アウトリガ張出幅 8.0m
PS+ブーム+2.5m+32.3mLJ

ブーム長さ ブーム起伏角 作業半径 (m)	35.3m			40.4m			45.4m		50.5m		単位:t	
	83°	75°	68°	83°	75°	68°	83°	75°	83°	75°		
18.0	30.8											
20.0	27.6			20.8								
22.0	24.1			20.3			16.5		12.5			
24.0	21.3			18.9			16.1		12.1			
26.0	19.0			18.1			15.8		11.9			
28.0	17.1	13.1		16.3			15.1		11.7			
30.0	15.5	11.8		14.7	10.2		13.6		11.6			
32.0	14.1	10.7		13.4	9.1		12.4	7.2	11.3			
34.0	12.9	9.7	6.1	12.3	8.2		11.3	6.5	10.6	5.2		
36.0		8.8	5.4		7.4			5.8	9.7	4.6		
38.0		8.0	4.8		6.7	3.1		5.1		4.0		
40.0		7.3	4.3		6.0	2.7		4.6		3.5		
42.0			3.8		5.4	2.3		4.1		3.1		
44.0			3.3			1.9				2.7		
46.0						1.6						
θ(°)	8~64	8~61	8~52	8~60	8~69	8~53	8~58	8~57	8~65	8~62		
標準フック	35t											
フック質量	950kg											
標準巻掛本数	3			2								